

Service Manual

Multi-Function printer

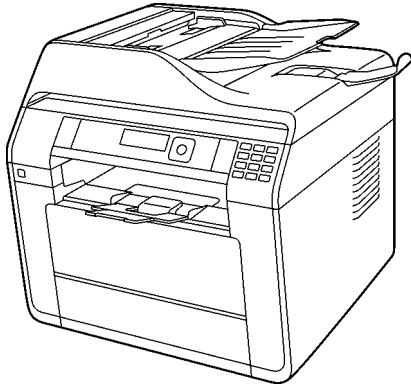

Model No. **KX-MB2230EU**
KX-MB2270EU
KX-MB2515EU
KX-MB2545EU
KX-MB2575EU
DP-MB310EU

(for Europe)

⚠ WARNING

This service information is designed for experienced repair technicians only and is not designed for use by the general public. It does not contain warnings or cautions to advise non-technical individuals of potential dangers in attempting to service a product. Products powered by electricity should be serviced or repaired only by experienced professional technicians. Any attempt to service or repair the product or products dealt with in this service information by anyone else could result in serious injury or death.

IMPORTANT SAFETY NOTICE

There are special components used in this equipment which are important for safety. These parts are marked by ⚠ in the Schematic Diagrams, Circuit Board Diagrams, Exploded Views and Replacements Parts List. It is essential that these critical parts should be replaced with manufacturer's specified parts to prevent shock, fire or other hazards. Do not modify the original design without permission of manufacturer.

IMPORTANT INFORMATION ABOUT LEAD FREE, (PbF), SOLDERING

If lead free solder was used in the manufacture of this product, the printed circuit boards will be marked PbF. Standard leaded, (Pb), solder can be used as usual on boards without the PbF mark.

When this mark does appear please read and follow the special instructions described in this manual on the use of PbF and how it might be permissible to use Pb solder during service and repair work.

When you note the serial number, write down all 11 digits. The serial number may be found on the side of the unit.

Panasonic®

© Panasonic System Networks Co., Ltd. 2013
 Unauthorized copying and distribution is a violation
 of law.

TABLE OF CONTENTS

	PAGE		PAGE
1 Safety Precautions	6	6.8.3. Normal torque 1-2 phase excitation (half step)	61
1.1. For Service Technicians	6	6.8.4. Flat torque 1-2 phase excitation (half step)	62
1.2. AC Caution	6	6.8.5. W 1-2 phase excitation (Quarter step)	63
1.3. Personal Safety Precautions	7	6.8.6. 2W1-2 phase excitation	64
1.3.1. Moving Sections of the Unit	7	6.9. FAN Motor Section	65
1.3.2. Live Electrical Sections	7	6.9.1. General	65
1.4. Service Precautions	7	6.9.2. Circuit Diagram of FAN	65
1.4.1. Precautions to Prevent Damage from Static Electricity	7	6.9.3. Fan Control	65
2 Warning	8	6.9.4. Control table	66
2.1. About Lead Free Solder (PbF: Pb free)	8	6.9.5. Waveform	67
2.1.1. Suggested PbF Solder	8	6.9.6. Abnormal Detect and Lock Protect Block	67
2.2. Discarding of P. C. Board	9	6.10. Solenoid Driver Section	69
2.3. Insulation Resistance Test	9	6.10.1. Optional Lower input Tray Motor (OPF Motor) Drive and Solenoid Drive circuit	71
2.4. Battery Caution	9	6.11. LSU (Laser Scanning Unit) Section	75
2.5. Laser Beam and Fuser Unit Section	9	6.12. Sensors and Switches Section	77
2.6. Note for Repairing	10	6.12.1. Pick Up Sensor	78
3 Specifications	11	6.12.2. Resist Sensor	78
4 General/Introduction	14	6.12.3. PTO Sensor (Print timing Sensor)	79
4.1. Accessory information	14	6.12.4. ADU Sensor	79
4.2. Translation Lists	14	6.12.5. Exit Sensor	80
4.2.1. Report messages	14	6.12.6. Document Sensor	80
4.2.2. General messages	17	6.12.7. Read Position Sensor	81
4.2.3. Interface messages	26	6.12.8. RADF JAM Sensor (Only for KX-MB25** and DP-MB***)	82
5 Features	28	6.12.9. MPT Sensor	82
5.1. General Features	28	6.12.10. Paper Sensor	83
5.2. Hardware Requirements for Multi-Function Software	28	6.12.11. CS open Sensor	83
6 Technical Descriptions	30	6.12.12. Rear door Sensor	84
6.1. Connection Diagram	30	6.12.13. Interlock switch	85
6.2. General Block Diagram	31	6.12.14. Toner Sensor	86
6.3. Main Board Section	34	6.12.15. OPC Life Sensor Circuit	87
6.3.1. Data Flow	34	6.12.16. Toner Life Sensor Circuit	88
6.3.2. RTC Backup Circuit	44	6.12.17. Drum and Toner Detetion	89
6.3.3. Modem Circuit Operation (Fax supported models only)	44	6.12.18. Power Switch	91
6.3.4. TEL Line Section (Fax supported models only)	45	6.13. Operation Board Section	92
6.4. NCU Section (Fax supported models only)	47	6.14. LCD Section	93
6.4.1. General	47	6.15. HVPS (High Voltage Power Supply) Section	95
6.4.2. EXT. TEL. Line Relay (RLY100)	47	6.15.1. HVPS Specification	95
6.4.3. Bell Detection Circuit	47	6.15.2. CHG-BIAS (Charge BIAS)/GRID/ UNIT	95
6.4.4. Remote FAX Activation Circuit	47	6.15.3. DEV DC BIAS UNIT	96
6.4.5. TAM Interface Circuit	47	6.15.4. DEV AC BIAS UNIT	96
6.5. ITS (Integrated telephone System) and Monitor Section (Fax supported models only)	48	6.15.5. TRA (+) BIAS (Transfer (+) BIAS)/TRA (-) BIAS (Transfer (-) BIAS) UNIT	96
6.5.1. General	48	6.16. Heat Lamp Control Circuit	97
6.6. CIS Control Section	49	6.17. Power Saving (Sleep) Function	102
6.7. Motor Drive Section	50	6.18. Main Board Power Supply Section	103
6.7.1. Main Motor Control Circuit	50	6.18.1. 3.3V and 1.2V Power Supply Descriptions	103
6.7.2. Scanner motor drive circuit	52	6.18.2. 5V Power Supply Descriptions	103
6.7.3. Timing Chart and Wave Form of Motors	55	6.18.3. 24V Power Supply Descriptions	104
6.8. Timing chart and wave form of scanner motors	59	6.18.4. 2.5V Power Supply Descriptions	104
6.8.1. Drive mode of FB and ADF motor	59	6.18.5. Main Unit Power Supply Condition	104
6.8.2. 2 phase excitation	60	6.18.6. Main Unit Power Supply Sequence	105
		6.18.7. Wave Form	105
		6.19. Power Supply Board Section	106
		6.20. Mechanical Operation	107

6.20.1. Print Process-----	107	12.3.3. Simple Check List-----	184
6.20.2. Scanning (ADF) (Only for KX-MB22**)-	108	12.3.4. Simplified Troubleshooting Guide-----	185
6.20.3. Scanning (ADF) (Only for KX-MB25** and DP-MB***)-----	109	12.3.5. CALL SERVICE Troubleshooting Guide ----	188
6.20.4. Double side Scanning-----	110	12.3.6. Print-----	197
6.21. WirelessLAN Section (WirelessLAN supported models only)-----	112	12.3.7. Recording Paper Feed-----	203
7 Location of Controls and Components-----	113	12.3.8. ADF (Auto document feed) Section -----	209
7.1. Overview-----	113	12.3.9. Communication Section -----	215
7.1.1. Front View-----	113	12.3.10. Special Service Journal Reports -----	220
7.1.2. Rear View-----	114	12.3.11. Initializing Error -----	233
7.2. Control Panel-----	115	12.3.12. Analog Section (Fax supported models only)-----	234
8 Installation Instructions-----	116	12.3.13. Operation Panel Section -----	237
8.1. Installation-----	116	12.3.14. Sensor Section-----	237
8.1.1. Installation Space-----	116	12.3.15. Motor Section -----	244
8.1.2. Recording Paper-----	117	12.3.16. LSU Section -----	247
8.1.3. Documents the Unit Can Send-----	123	12.3.17. CIS Control Section-----	248
8.1.4. Using the Automatic Document Feeder-----	123	12.3.18. High Voltage Value Check Point-----	250
8.1.5. Toner Cartridge and drum cartridge-----	125	12.3.19. High Voltage Section -----	251
8.1.6. Required Computer Environment-----	128	12.3.20. USB Section-----	256
8.1.7. Installing software (including printer, scanner and other drivers)-----	129	12.3.21. LAN Section -----	261
8.2. Connections-----	131	12.3.22. Main Board Section-----	264
9 Operating Instructions-----	133	12.3.23. Low Voltage Power Supply Board (SMPS Board)Section-----	266
9.1. Your Logo (Fax supported models only)-----	133	12.3.24. Wireless LAN Section-----	268
9.2. Character Entry (Fax or LAN supported models only)-----	134	12.4. Recording Paper Jam-----	269
9.2.1. To Select Characters Using [] or []-----	135	12.4.1. When the Recording Paper has Jammed Inside of the Unit -----	269
10 Test Mode-----	136	12.4.2. When the Recording Paper is not Fed Into the Unit Properly-----	275
10.1. Test Functions-----	136	12.4.3. When the recording paper in the manual tray/multi-purpose tray is not fed into the unit properly-----	275
10.1.1. DTMF Single Tone Transmit Selection ----	137	12.5. Document jams (Automatic document feeder) -	276
10.1.2. Button Code Table (KX-MB2230/KX- MB2545 ONLY)-----	138	13 Service Fixture & Tools-----	279
10.1.3. Button Code Table (KX-MB2270/KX- MB2575 ONLY)-----	138	14 Disassembly and Assembly Instructions-----	280
10.1.4. Button Code Table (KX-MB2515 ONLY)-----	139	14.1. First of All -----	280
10.1.5. Button Code Table (DP-MB310 ONLY) ----	139	14.2. Flow Chart for Disassembly-----	281
10.1.6. Print Test Pattern -----	140	14.3. Disassembly for Main Parts -----	282
11 Service Mode-----	141	14.3.1. Remove the Left Cover -----	282
11.1. Programming and Lists -----	141	14.3.2. Remove the Main Board (SMPS Board, VARISTOR Board)-----	283
11.1.1. Operation -----	141	14.3.3. Remove the HVPS Board-----	285
11.1.2. Operation Flow-----	141	14.3.4. Remove the Interlock Switch Board -----	285
11.1.3. Service Function Table -----	142	14.3.5. Remove the Antenna(V) Board-----	286
11.1.4. Service Function Table (Fax supported models only)-----	143	14.3.6. Remove the Speaker-----	286
11.1.5. Memory Clear Specification-----	145	14.3.7. Remove the Terminal Plate/TNR Contact Board/OPC Contact Board/Print Sensor Relay Board/Toner Sensor Board-----	287
11.2. User Mode (The list below is an example of the SYSTEM SETUP LIST the unit prints out.) -	146	14.3.8. Remove the Right Cover -----	288
11.3. Service Mode Settings (Example of a printed out list) -----	161	14.3.9. Remove the Drive Unit-----	289
11.4. History (Example of a printed out list)-----	164	14.3.10. Remove the Main Motor-----	290
11.4.1. Descriptions of the History Report-----	170	14.3.11. Remove the Clutch -----	290
12 Troubleshooting Guide-----	171	14.3.12. Remove the Center Relay Board-----	291
12.1. User Recoverable Errors -----	171	14.3.13. Remove the MPT Unit (MPT Relay Board) -	291
12.2. Remote Programming -----	175	14.3.14. Remove the FAN -----	292
12.2.1. Entering the Remote Programming Mode and Changing Service Codes -----	176	14.3.15. Remove the FB Unit-----	293
12.2.2. Program Mode Table-----	177	14.3.16. Remove the Rear Door and Rear Cover ---	294
12.3. Troubleshooting Details-----	183	14.3.17. Remove the ADF Unit / ADF-Motor / ADF Relay Board -----	295
12.3.1. Outline-----	183	14.3.18. DOCU Sensor Board / RPS Board / RADF Board-----	297
12.3.2. Starting Troubleshooting-----	183		

14.3.19. Disassemble the FB Unit (FB-Motor)-----	298	15.6.1. NG Example-----	334
14.3.20. Disassemble the Operation Panel Assy-----	299	15.7. Test Chart-----	335
14.3.21. Remove the Fuser Unit (Fuser Board)-----	299	15.7.1. ITU-T No.1 Test Chart-----	335
14.3.22. Remove the Top Cover-----	300	15.7.2. ITU-T No.2 Test Chart-----	336
14.3.23. Remove the Main Chassis-----	301	16 Schematic Diagram-----	337
14.4. Installation Position of The Lead-----	306	16.1. For Schematic Diagram-----	337
14.4.1. Main Cabinet Section-----	306	16.2. Main Board (KX-MB2230)-----	338
14.4.2. Wire dressing on the Left Side Section(Main Board)(1)-----	307	16.2.1. Main Board(1)-----	338
14.4.3. Wire dressing on the Left Side Section(Main Board)(2)-----	308	16.2.2. Main Board(2)-----	342
14.4.4. Wire dressing on the Left Side Section(Main Board) (3)-----	309	16.2.3. Main Board(3)-----	344
14.4.5. Wire dressing on the Left Side Section(Main Board) (4)-----	310	16.2.4. Main Board(4)-----	346
14.4.6. Wire dressing on the Right Side Section (1)-----	311	16.2.5. Main Board(5)-----	348
14.4.7. Wire dressing on the Right Side Section (2)-----	312	16.2.6. Main Board(6)-----	350
14.4.8. FB Unit (1)-----	313	16.3. Main Board (KX-MB2270)-----	352
14.4.9. FB Unit (2)-----	314	16.3.1. Main Board(1)-----	352
14.4.10. Fuser Lead-----	315	16.3.2. Main Board(2)-----	356
15 Maintenance-----	316	16.3.3. Main Board(3)-----	358
15.1. Maintenance Items and Component Locations- 316		16.3.4. Main Board(4)-----	360
15.1.1. Outline-----	316	16.3.5. Main Board(5)-----	362
15.1.2. Maintenance Check Items/Component Locations-----	316	16.3.6. Main Board(6)-----	364
15.2. Maintenance-----	318	16.4. Main Board (KX-MB2515)-----	366
15.2.1. Cleaning the White Plates and Glass-----	318	16.4.1. Main Board(1)-----	366
15.2.2. Cleaning the Document Feeder Rollers-----	320	16.4.2. Main Board(2)-----	370
15.2.3. Cleaning the recording paper feeder rollers of the multi-purpose tray-----	321	16.4.3. Main Board(3)-----	372
15.2.4. Cleaning the pickup rollers-----	322	16.4.4. Main Board(4)-----	374
15.2.5. Cleaning the drum cartridge-----	323	16.4.5. Main Board(5)-----	376
15.3. Printing Operation Principle-----	324	16.4.6. Main Board(6)-----	378
15.3.1. Process Chart and Process BIAS-----	324	16.5. Main Board (KX-MB2545)-----	380
15.3.2. Charging-----	324	16.5.1. Main Board(1)-----	380
15.3.3. Exposing-----	325	16.5.2. Main Board(2)-----	384
15.3.4. Developing and Transcription-----	325	16.5.3. Main Board(3)-----	386
15.3.5. Cleaning of Transfer Roller-----	326	16.5.4. Main Board(4)-----	388
15.3.6. Fixing-----	327	16.5.5. Main Board(5)-----	390
15.4. Terminal Guide of the ICs Transistors and Diodes-----	328	16.5.6. Main Board(6)-----	392
15.4.1. Main Board(1)-----	328	16.6. Main Board (KX-MB2575)-----	394
15.4.2. Main Board(2)-----	329	16.6.1. Main Board(1)-----	394
15.4.3. Operation Board-----	329	16.6.2. Main Board(2)-----	398
15.4.4. Print Sensor Relay Board-----	329	16.6.3. Main Board(3)-----	400
15.4.5. Center Relay Board-----	329	16.6.4. Main Board(4)-----	402
15.4.6. Varistor Board-----	329	16.6.5. Main Board(5)-----	404
15.4.7. ADF Relay Board-----	330	16.6.6. Main Board(6)-----	406
15.4.8. MPT Relay Board-----	330	16.7. Main Board (DP-MB310)-----	408
15.4.9. High Voltage Power Supply Board (HVPS Board)-----	330	16.7.1. Main Board(1)-----	408
15.4.10. Low Voltage Power Supply Board (SMPS Board)-----	330	16.7.2. Main Board(2)-----	412
15.5. How to Replace the Flat Package IC-----	331	16.7.3. Main Board(3)-----	414
15.5.1. Preparation-----	331	16.7.4. Main Board(4)-----	416
15.5.2. Removal Procedure-----	331	16.7.5. Main Board(5)-----	418
15.5.3. Procedure-----	332	16.7.6. Main Board(6)-----	420
15.5.4. Removing Solder From Between Pins-----	332	16.8. Sensor Board (KX-MB2230)-----	422
15.6. Main Board Section-----	333	16.8.1. Operation Board-----	422
		16.8.2. Sensor Board-----	423
		16.9. Sensor Board (KX-MB2270)-----	424
		16.9.1. Operation Board-----	424
		16.9.2. Sensor Board-----	425
		16.10. Sensor Board (KX-MB2515)-----	426
		16.10.1. Operation Board-----	426
		16.10.2. Sensor Board-----	427
		16.11. Sensor Board (KX-MB2545)-----	428
		16.11.1. Operation Board-----	428
		16.11.2. Sensor Board-----	429
		16.12. Sensor Board (KX-MB2575)-----	430

16.12.1. Operation Board -----	430	18.1.12. Main Chassis Section -----	470
16.12.2. Sensor Board -----	431	18.1.13. LSU Section -----	472
16.13. Sensor Board (DP-MB310) -----	432	18.1.14. Pick-Up Block Section -----	474
16.13.1. Operation Board -----	432	18.1.15. Paper Feed Section -----	476
16.13.2. Sensor Board -----	433	18.1.16. Left Side Cabinet Section -----	478
16.14. Back Light Board -----	434	18.1.17. Right Side Cabinet Section (1)-----	480
16.15. High Voltage Power Supply Board (HVPS Board) -----	435	18.1.18. Right Side Cabinet Section (2)-----	482
16.16. Low Voltage Power Supply Board (SMPS Board) -----	436	18.1.19. Standard Input Tray Section-----	484
17 Printed Circuit Board-----	438	18.1.20. Front Cover Section -----	486
17.1. Main Board -----	438	18.1.21. Manual Tray Section-----	488
17.1.1. Main Board: Component View-----	438	18.1.22. Actual Size of Screws and Washer-----	490
17.1.2. Main Board: Bottom View-----	439	18.1.23. Accessories and Packing Materials -----	492
17.2. Sensor Board -----	440	18.2. Electrical Parts List -----	494
17.2.1. Operation Board -----	440	18.2.1. Main Board (For KX-MB2230EU) -----	494
17.2.2. PICK UP RELAY Board -----	441	18.2.2. Main Board (For KX-MB2270EU) -----	500
17.2.3. PRINT SENSOR RELAY Board-----	441	18.2.3. Main Board (For KX-MB2515EU) -----	506
17.2.4. TONER SENSOR Board-----	441	18.2.4. Main Board (For KX-MB2545EU) -----	511
17.2.5. INTERLOCK SWITCH Board-----	441	18.2.5. Main Board (For KX-MB2575EU) -----	518
17.2.6. CENTER RELAY Board-----	441	18.2.6. Main Board (For DP-MB310EU)-----	524
17.2.7. REAR SENSOR Board-----	442	18.2.7. Sensor Board-----	530
17.2.8. FUSER Board -----	442	18.2.8. High Voltage Power Supply Board-----	537
17.2.9. VARISTOR Board-----	442	18.2.9. Low Voltage Power Supply Board -----	537
17.2.10. OPC CONTACT Board -----	442		
17.2.11. TONER CONTACT Board -----	442		
17.2.12. DOCU SENSOR Board -----	442		
17.2.13. RPS Board -----	443		
17.2.14. ADF RELAY Board -----	443		
17.2.15. POWER SWITCH Board-----	443		
17.2.16. RADF Board -----	443		
17.2.17. MPT RELAY Board-----	443		
17.2.18. WLAN ANT_V Board -----	443		
17.2.19. WLAN ANT_W Board-----	443		
17.2.20. ONE TOUCH KEY Board-----	444		
17.3. Back Light Board -----	445		
17.3.1. Back Light Board-----	445		
17.4. High Voltage Power Supply Board -----	446		
17.4.1. High Voltage Power Supply Board: Component View-----	446		
17.4.2. High Voltage Power Supply Board: Bottom View -----	446		
17.5. Low Voltage Power Supply Board-----	447		
17.5.1. Low Voltage Power Supply Board: Component View-----	447		
17.5.2. Low Voltage Power Supply Board: Bottom View -----	447		
18 Exploded View and Replacement Parts List -----	449		
18.1. Cabinet, Mechanical and Electrical Parts Location-----	449		
18.1.1. General Section-----	449		
18.1.2. Operation Panel Section-----	450		
18.1.3. ADF Section (1) -----	452		
18.1.4. ADF Section (2) -----	454		
18.1.5. ADF_Separator Section 1 -----	456		
18.1.6. ADF_Upper Section-----	458		
18.1.7. Top Cover-----	460		
18.1.8. Switch_back Section-----	462		
18.1.9. ADF_BASE Section-----	464		
18.1.10. FB Unit Section-----	466		
18.1.11. Rear side and Fuser Unit Section -----	468		

1 Safety Precautions

1. Before servicing, unplug the AC power cord to prevent an electric shock.
2. When replacing parts, use only the manufacturer's recommended components.
3. Check the condition of the power cord. Replace if wear or damage is evident.
4. After servicing, be sure to restore the lead dress, insulation barriers, insulation papers, shields, etc.
5. Before returning the serviced equipment to the customer, be sure to perform the following insulation resistance test to prevent the customer from being exposed to shock hazards.

1.1. For Service Technicians

• **Repair service shall be provided in accordance with repair technology information such as service manual so as to prevent fires, injury or electric shock, which can be caused by improper repair work.**

1. When repair services are provided, neither the products nor their parts or members shall be remodeled.
2. If a lead wire assembly is supplied as a repair part, the lead wire assembly shall be replaced.
3. FASTON terminals shall be plugged straight in and unplugged straight out.

• **ICs and LSIs are vulnerable to static electricity.**

When repairing, the following precautions will help prevent recurring malfunctions.

1. Cover the plastic part's boxes with aluminum foil.
2. Ground the soldering irons.
3. Use a conductive mat on the worktable.
4. Do not touch the IC or LSI pins with bare fingers.

1.2. AC Caution

For safety, before closing the lower cabinet, please make sure of the following precautions.

1. The earth lead is fixed with the screw.
2. The AC connector is connected properly.

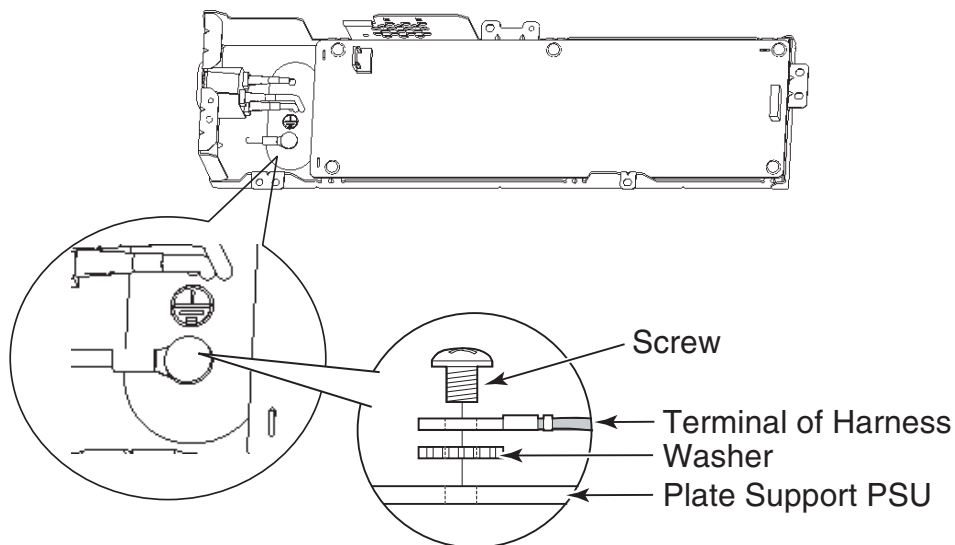

1.3. Personal Safety Precautions

1.3.1. Moving Sections of the Unit

Be careful not to let your hair, clothes, fingers, accessories, etc., become caught in any moving sections of the unit.

The moving sections of the unit are the rollers and a gear. There is a separation roller and a document feed roller which are rotated by the document feed motor. A gear rotates the two rollers. Be careful not to touch them with your hands, especially when the unit is operating.

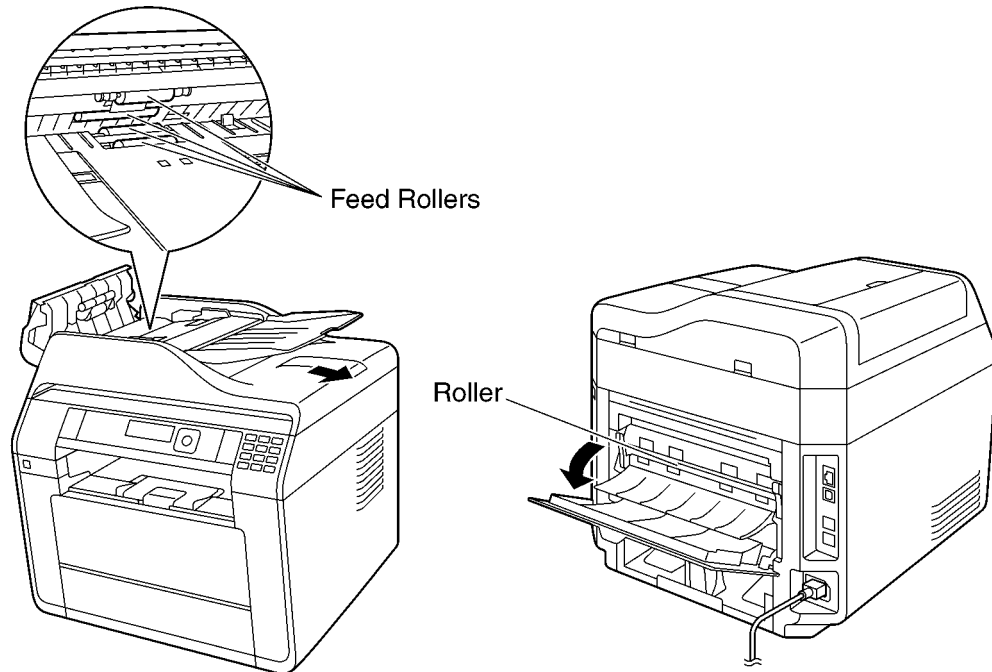

1.3.2. Live Electrical Sections

All the electrical sections of the unit supplied with AC power by the AC power cord are live.

Never disassemble the unit for service with the AC power supply plugged in.

CAUTION:

AC voltage is supplied to the primary side of the Low Voltage Power Supply Board (SMPS board). Therefore, always unplug the AC power cord before disassembling for service.

Discharge the primary electrolytic capacitor before touching the SMPS board.

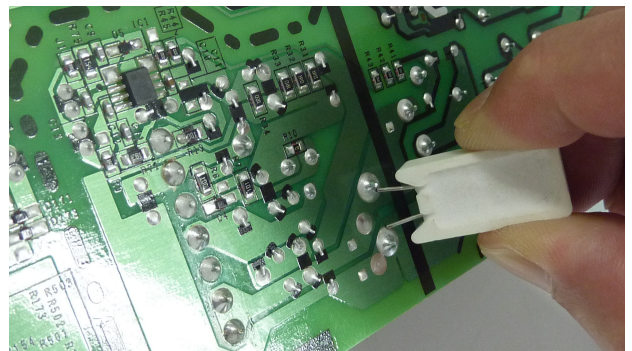
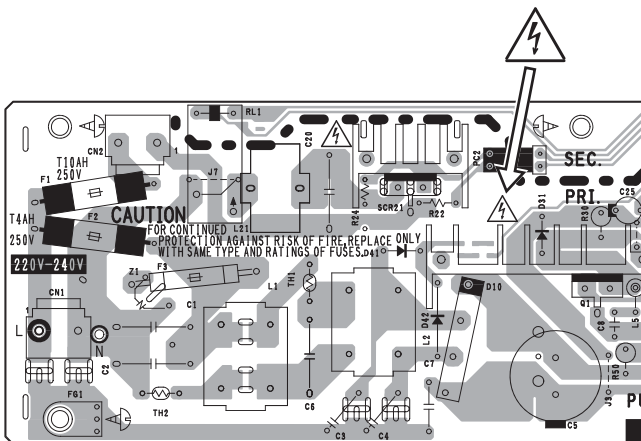

Discharge the primary electrolytic capacitor

1.4. Service Precautions

1.4.1. Precautions to Prevent Damage from Static Electricity

Electrical charges accumulate on a person. For instance, clothes rubbing together can damage electric elements or change their electrical characteristics. In order to prevent static electricity, touch a metallic part that is grounded to release the static electricity. Never touch the electrical sections such as the Power Supply boards, etc.

2 Warning

2.1. About Lead Free Solder (PbF: Pb free)

Note:

In the information below, Pb, the symbol for lead in the periodic table of elements, will refer to standard solder or solder that contains lead.

We will use PbF solder when discussing the lead free solder used in our manufacturing process which is made from Tin, (Sn), Silver, (Ag), and Copper, (Cu).

This model, and others like it, manufactured using lead free solder will have PbF stamped on the PCB. For service and repair work we suggest using the same type of solder although, with some precautions, standard Pb solder can also be used.

Caution

- PbF solder has a melting point that is 50° ~ 70° F, (30° ~ 40°C) higher than Pb solder. Please use a soldering iron with temperature control and adjust it to 700° ± 20° F, (370° ± 10°C). In case of using high temperature soldering iron, please be careful not to heat too long.
- PbF solder will tend to splash if it is heated much higher than its melting point, approximately 1100°F, (600°C).
- If you must use Pb solder on a PCB manufactured using PbF solder, remove as much of the original PbF solder as possible and be sure that any remaining is melted prior to applying the Pb solder.
- When applying PbF solder to double layered boards, please check the component side for excess which may flow onto the opposite side (See figure, below).

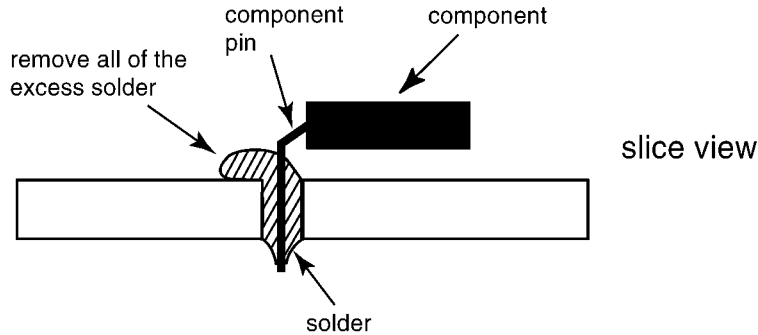

2.1.1. Suggested PbF Solder

There are several types of PbF solder available commercially. While this product is manufactured using Tin, Silver, and Copper, (Sn+Ag+Cu), you can also use Tin and Copper, (Sn+Cu), or Tin, Zinc, and Bismuth, (Sn+Zn+Bi). Please check the manufacturer’s specific instructions for the melting points of their products and any precautions for using their product with other materials.

The following lead free (PbF) solder wire sizes are recommended for service of this product: 0.3mm, 0.6mm and 1.0mm.

0.3mm X 100g	0.6mm X 100g	1.0mm X 100g

2.2. Discarding of P. C. Board

When discarding P. C. Board, delete all personal information such as telephone directory and caller list or scrap P. C. Board.

2.3. Insulation Resistance Test

1. Unplug the power cord and short the two prongs of the plug with a jumper wire.
2. Turn on the power switch.
3. Measure the resistance value with an ohmmeter between the jumpered AC plug and each exposed metal cabinet part (screw heads, control shafts, bottom frame, etc.).

Note: Some exposed parts may be isolated from the chassis by design. These will read infinity.

4. If the measurement is outside the specified limits, there is a possibility of a shock hazard.

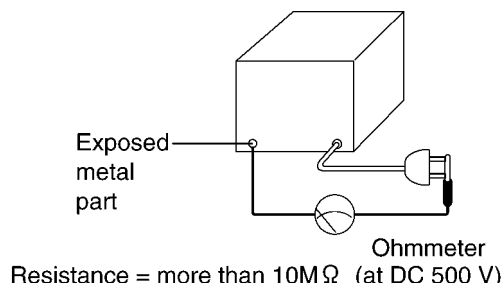

2.4. Battery Caution

CAUTION

Danger of explosion if the battery is incorrectly replaced. Replace only with the same or equivalent type recommended by the manufacturer. Dispose of used batteries according to the manufacturer's Instructions.

The lithium battery is a critical component (type No.CR2032). Please observe for the proper polarity and the exact location when replacing it and soldering the replacement lithium battery in.

2.5. Laser Beam and Fuser Unit Section

- The printer of this unit utilizes a laser. Use of controls or adjustments or performance of procedures other than those specified herein may result in hazardous radiation exposure.
- The fuser unit is inside of the unit and gets hot. Do not touch it when removing the jammed paper or cleaning the lower glass.

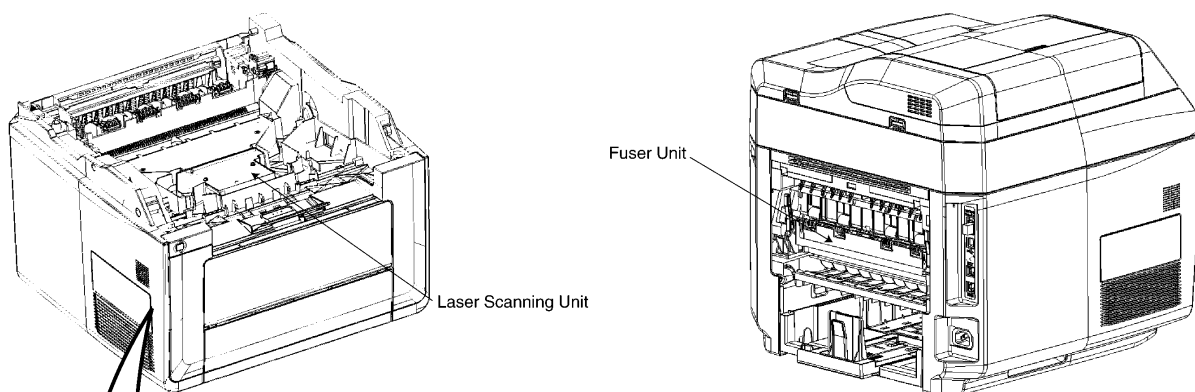

* In case of this figure, this Laser Caution Label is located on the other side of the LSU.



Laser Caution Label

CAUTION : Class 3B invisible laser radiation when open. Avoid exposure to the beam.

VORSICHT : Unsichtbare Laserstrahlung nach Klasse 3B beim Öffnen. Kontakt mit Strahlung meiden.

ATTENTION : Appareil à rayonnement laser de classe 3B. Rayonnement laser invisible dangereux en cas d'ouverture. Exposition au faisceau dangereuse.

ATENCIÓN : Clase 3B Radiación láser invisible al ser abierto. Evitar exponerse a los rayos.

WARNING : Klasse 3B. Osynlig laserstråling når denna del är öppen. Strålen är farlig.

VAROITUS : Avattaessa purkautuu luokan 3B näkymätöntä lasersäteilyä. Älä allista itseäsi säteilylle.

ADVARSEL : Usynlig laserstråling i klasse 3B ved åpning. Unngå utsættelse for stråling.

ADVARSEL : Klasse 3B, usynlig laserstråling ved åpning. Unngå eksponering for strålen.

警告 : 打开时有 3B 级不可见激光辐射。请避免暴露于光束。

ОСТОРОЖНО : При открытых крышках имеется невидимое лазерное излучение класса 3B. Не попадайте под воздействие лазерного излучения.

PNOT1506ZA

2.6. Note for Repairing

Caution

Please inform users of the danger of data being lost at the time of repair.

Data will be lost in the following situations.

1. When replacing the ROM ass'y.
2. When replacing the Main board ass'y.
3. When executing service mode #550 or #710. (Memory Clear)

There is a possibility of data loss in the following situations.

1. When removing a board.
2. When writing new software to ROM.

3 Specifications

Applicable Lines*¹:	Public Switched Telephone Network
Document Size:	Scanner glass: Max. 216mm in width, Max. 297mm in length Automatic document feeder: Max. 216mm/Min. 125mm in width, Max. 600mm/Min. 105mm in length
Effective Scanning Width:	208 mm
Effective Printing Width:	Letter/ Legal: 208mm A4: 202mm
Transmission Time*¹*²:	Approx. 4 s/page (ECM-MMR Memory transmission)* ³
Scanning Density:	Scanning resolution: Up to 600 × 1,200dpi (Optical) Up to 19,200 × 19,200dpi (Interpolated)
	Copy resolution: Up to 600 × 600dpi
	FAX resolution*¹: Horizontal: 8 pels/mm Vertical: 3.85 lines/mm -in standard resolution, 7.7 lines/mm -in fine/photo resolution, 15.4 lines/mm -in super fine resolution
Scanner Type:	Colour Contact Image Sensor (CIS)
Printer Type:	Laser Printer
Data Compression System*¹:	Modified Huffman (MH), Modified READ (MR), Modified Modified READ (MMR)
Modem Speed*¹:	33,600 / 31,200 / 28,800 / 26,400 / 24,000 / 21,600 / 19,200 / 16,800 / 14,400 / 12,000 / 9,600 / 7,200 / 4,800 / 2,400 bps; Automatic Fallback
Operating Environment:	10°C-32.5°C, 20%-70% RH (Relative Humidity)
Dimensions:	Approx. width 400mm x depth 413mm x height 400mm
Mass (Weight):	KX-MB2230/KX-MB2270: Approx. 15 kg KX-MB2515/KX-MB2545/KX-MB2575/DP-MB310: Approx. 16 kg
Power Consumption:	OFF* ⁴ : Less than 0.1W Sleep* ⁴ : KX-MB2230 Less than 1.0W* ⁵ Less than 1.3W* ⁶ KX-MB2270 Less than 1.0W* ⁵ Less than 1.3W* ⁶ Less than 2.3W* ⁷ KX-MB2515 Less than 1.0W* ⁵ Less than 1.3W* ⁶ KX-MB2545 Less than 1.0W* ⁵ Less than 1.3W* ⁶ KX-MB2575 Less than 1.0W* ⁵ Less than 1.3W* ⁶ Less than 2.3W* ⁷ DP-MB310 Less than 1.0W* ⁵ Less than 1.3W* ⁶ Ready: Approx. 55W Copy: Approx. 500W Maximum: Approx. 1000W (When the fuser lamp turns on)
Power Supply:	220-240V AC, 50Hz
Memory Capacity (for operation and storing memory):	64MB

Fax Memory Capacity*1:	KX-MB2230/KX-MB2270 3.1MB in total Approx. 80 pages of memory reception Approx. 150 pages of memory transmission KX-MB2545/KX-MB2575 7.3MB in total Approx. 350 pages of memory reception Approx. 200 pages of memory transmission DP-MB310 7.9MB in total Approx. 400 pages of memory reception Approx. 200 pages of memory transmission (Based on the ITU-T No. 1 Test Chart in standard resolution.)
Scan to Email Address Memory Capacity*8:	5 MB in total (including the header and email message) or 100 pages, whichever limit is reached first.
Scan to FTP Server Memory Capacity*8:	10 MB in total or 100 pages, whichever limit is reached first.
Scan to SMB Folder Memory Capacity*8:	10 MB in total or 100 pages, whichever limit is reached first.
Scan to USB memory capacity*9:	100 pages
Laser Diode Properties:	Laser output: Max. 10mW Wavelength: 760nm - 800nm Emission duration: Continuous
Print speed (pages per minute) (Approx.):	Simplex: KX-MB2230/KX-MB2270: A4: 28 ppm Letter: 29 ppm KX-MB2515/KX-MB2545/KX-MB2575/DP-MB310: A4: 30 ppm Letter: 31 ppm Duplex: A4: 28 ppm Letter: 29 ppm
Printing Resolution:	600 x 600dpi
CIS's LED Light Properties:	LED radiation output: Max. 1 mW Wavelength: Red 630nm typical Green 520nm typical Blue 465nm typical Emission duration: Continuous
Wireless LAN*10:	Antenna: 1 × 1 (Diversity) Transmission method: SISO (Single Input/Single Output) - OFDM, OFDM, DSSS Communication standard: IEEE802.11b/g/n Frequency range (centre frequency)/ Channel: 2.412 GHz - 2.472 GHz (1 - 13ch) Data transfer rate*11: IEEE802.11n: 6.5 - 72.2 Mbps IEEE802.11g: 6 - 54 Mbps IEEE802.11b: 1 - 11 Mbps Access method: Infrastructure mode/ad hoc mode Security*12: WPA/WPA2-PSK (TKIP/AES) Open System (WEP64/WEP128) WPS: PBC method (push button method), PIN method (PIN code method)

Internet fax^{*13}:**Communications protocol:** TCP/IP, SMTP, POP3, SMTP AUTH, POP before SMTP**Email format:** MIME Base 64 Content-type: Image/TIFF
Multipart/mixed (text/plain, Image/TIFF) attachment file
format**Data format:**

RFC3949 (RFC2301), TIFF-FX minimal set

Profile: TIFF-F

Encoding scheme: MH/MR/MMR

Maximum document size (Width × Length): 216 mm × 600 mm

Resolution:

8 dot × 3.85 lines/mm, 8 dot × 7.7 lines/mm, 8 dot × 15.4 lines/mm

Internet fax message confirmation: MDN**Compatible network types:** Ethernet (10 Base-T/100 Base-TX)**Models supporting transmission:** Internet fax compliant with the TTC standards

(JT-T37 full mode)

USB^{*14*15}LAN (10 Base-T/100 Base-TX)^{*8*14}Wireless LAN (IEEE802.11b/g/n)^{*10}**Computer interface:**^{*1} Only for models that support the fax feature.^{*2} Transmission speed depends on the page contents, resolution, telephone line conditions and capability of the other party's machine.^{*3} Transmission speed is based on the ITU-T No. 1 Test Chart with original mode. If the capability of the other party's machine is inferior to your unit, the transmission time may be longer.^{*4} Based on IEC 62301 standard.^{*5} Only when connected via USB interface and LAN mode is OFF.^{*6} Only when connected to a wired LAN.^{*7} Only when connected to a wireless LAN.^{*8} Only for models that support LAN connection.^{*9} Only for models that support USB memory.^{*10} Only for models that support wireless LAN.^{*11} The actual line speed may be different depending on the network environment and the wireless devices connected.^{*12} Depending on the wireless router (wireless access point) used, connections may not be possible between the unit and the wireless router. When connecting with 802.11n, select WPA-PSK (AES) or WPA2-PSK (AES) for security.^{*13} Only for models that support Internet fax.^{*14} To assure continued emission limit compliance:

. use only shielded Type-A male/Type-B male USB cable (Example: Hi-Speed USB 2.0 certified cable).

. use only shielded LAN cable (Category 5 (Cat-5) Ethernet cable).

^{*15} To protect the unit, use only shielded USB cable in areas where thunderstorms occur.**Note:**

- Design and specifications are subject to change without notice.
- The pictures and illustrations in these instructions may vary slightly from the actual product.

4 General/Introduction

4.1. Accessory information

Replacement accessory

To ensure that the unit operates properly, we recommend the use of Panasonic toner and drum cartridges.

For KX-MB2230/KX-MB2270

Accessory	Model No. (Part No.)	Approximate yield (pages)
Toner cartridge	KX-FAT420X	1,500*1
	KX-FAT430X	3,000*1
Drum cartridge	KX-FAD422X	18,000

For KX-MB2515/KX-MB2545/KX-MB2575

Accessory	Model No. (Part No.)	Approximate yield (pages)
Toner cartridge	KX-FAT420X	1,500*1
	KX-FAT430X	3,000*1
	KX-FAT431X	6,000*1
Drum cartridge	KX-FAD422X	18,000

For DP-MB310

Accessory	Model No. (Part No.)	Approximate yield (pages)
Toner cartridge	DQ-TCC008X	8,000*1
Drum cartridge	DQ-DCC018X	18,000

*1 Declared yield value is in accordance with ISO/IEC 19752. Actual yields may vary based on types of images printed and other factors.

Optional accessory

For KX-MB2515/KX-MB2545/KX-MB2575

Accessory	Model No. (Part No.)
Lower Input tray	KX-FAP107

For DP-MB310

Accessory	Model No. (Part No.)
Lower Input tray	KX-FAP107

Note:

- ISO/IEC 19752 standard is as follows:
 - Environment: 23 ± 2°C / 50 ± 10% RH
 - Print mode: Continuous printing

4.2. Translation Lists

4.2.1. Report messages

ENGLISH	CZECH
COMMUNICATION ERROR	CHYBA PRI KOMUNIKACI
DOCUMENT JAMMED	ZMACKANY DOKUMENT
ERROR-NOT YOUR UNIT	VAS FAX JE BEZ ZAVADY
MEMORY FULL	PREPLNENA PAMET
NO DOCUMENT / FAILED PICKUP	CHYBI DOKUMENT / CHYBNE PODANI
OTHER FAX NOT RESPONDING	PROTEJSI FAX NEKOMUNIKUJE
PRESSED THE 'Stop' KEY	STISKNU TO TLACITKO 'Stop'
THE COVER WAS OPENED	OTEVRENY KRYT
OK	OK

ENGLISH	FRENCH
COMMUNICATION ERROR	ERREUR DE COMMUNICATION
DOCUMENT JAMMED	BOURRAGE DE DOCUMENT
ERROR-NOT YOUR UNIT	ERREUR - AUTRE APPAREIL
MEMORY FULL	MÉMOIRE PLEINE
NO DOCUMENT / FAILED PICKUP	DOCUMENT ABSENT / ÉCHEC PAPIER
OTHER FAX NOT RESPONDING	PAS DE RÉPONSE
PRESSED THE 'Stop' KEY	APPUYER SUR LA TOUCHE 'Stop'
THE COVER WAS OPENED	LE COUVERCLE A ÉTÉ OUVERT
OK	OK

ENGLISH	GERMAN
COMMUNICATION ERROR	Kommunikationsfehler
DOCUMENT JAMMED	Dokument gestaut
ERROR-NOT YOUR UNIT	Fehler - Gegenstelle
MEMORY FULL	Speicher voll
NO DOCUMENT / FAILED PICKUP	Kein Dokument/Fehleinzug
OTHER FAX NOT RESPONDING	Gegenstelle antwortet nicht
PRESSED THE 'Stop' KEY	'Stop' Taste gedrückt
THE COVER WAS OPENED	Frontklappe geöffnet
OK	OK

ENGLISH	HUNGARIAN
COMMUNICATION ERROR	Átviteli hiba
DOCUMENT JAMMED	Irat elakadt
ERROR-NOT YOUR UNIT	A hiba nem Önnél van
MEMORY FULL	Memória megtelt
NO DOCUMENT / FAILED PICKUP	Nincs irat / Átviteli hiba
OTHER FAX NOT RESPONDING	Másik fax nem felel
PRESSED THE 'Stop' KEY	'Stop' gomb megnyomva
THE COVER WAS OPENED	Fedél nyitva
OK	Ok

ENGLISH	POLISH
COMMUNICATION ERROR	BŁĄD KOMUNIKACJI
DOCUMENT JAMMED	DOKUMENT ZABLOKOWANY
ERROR-NOT YOUR UNIT	BŁĄD - DRUGI TELEFAKS
MEMORY FULL	PAMIĘĆ PEŁNA
NO DOCUMENT / FAILED PICKUP	BRAK DOKUMENTU / BLAD POBIERANIA
OTHER FAX NOT RESPONDING	DRUGI TELEFAKS NIE ODPOWIADA
PRESSED THE 'Stop' KEY	NACIŚNIĘTO 'Stop'
THE COVER WAS OPENED	OTWARTA POKRYWA
OK	OK

ENGLISH	PORTUGUESE
COMMUNICATION ERROR	ERRO DE COMUNICAÇÃO
DOCUMENT JAMMED	DOCUMENTO ENCRAVADO
ERROR-NOT YOUR UNIT	ERRO DO OUTRO EQUIPAMENTO
MEMORY FULL	MEMÓRIA CHEIA
NO DOCUMENT / FAILED PICKUP	SEM DOCUMENTO / FALHA AO PUXAR
OTHER FAX NOT RESPONDING	NÃO ATENDE
PRESSED THE 'Stop' KEY	PRIMA A TECLA 'Stop'
THE COVER WAS OPENED	TAMPA ABERTA
OK	OK

ENGLISH	SLOVAK
COMMUNICATION ERROR	CHYBA PRI KOMUNIKACII
DOCUMENT JAMMED	UVIAZNUTY DOKUMENT
ERROR-NOT YOUR UNIT	CHYBA MIMO PRISTROJA
MEMORY FULL	PAMAT JE PLNA
NO DOCUMENT / FAILED PICKUP	ZIADNY DOKUMENT / ZLE ZAVEDENIE
OTHER FAX NOT RESPONDING	VOLANA STANICA NEPRIJALA FAX
PRESSED THE 'Stop' KEY	STLACILI STE TLACIDLO 'Stop'
THE COVER WAS OPENED	OTVORENY KRYT
OK	V PORIADKU

ENGLISH	SPANISH
COMMUNICATION ERROR	ERROR DE COMUNICACIÓN
DOCUMENT JAMMED	DOCUMENTO ATASCADO
ERROR-NOT YOUR UNIT	ERROR - NO EN SU EQUIPO
MEMORY FULL	MEMORIA LLENA
NO DOCUMENT / FAILED PICKUP	SIN DOCUMENTO/ERROR RECOGIDA
OTHER FAX NOT RESPONDING	EL OTRO FAX NO RESPONDE
PRESSED THE 'Stop' KEY	PULSÓ LA TECLA 'Stop'
THE COVER WAS OPENED	LA CUBIERTA ESTA ABIERTA
OK	COMUNICACIÓN CORRECTA

ENGLISH	TURKISH
COMMUNICATION ERROR	İLETİŞİM HATASI
DOCUMENT JAMMED	DOKÜMAN SIKIŞTI
ERROR-NOT YOUR UNIT	HATA - FAKSINIZDA DEĞİL
MEMORY FULL	HAFIZA DOLU
NO DOCUMENT / FAILED PICKUP	DOKÜMAN YOK / KAĞIDI DÜZELTİN
OTHER FAX NOT RESPONDING	CEVAP YOK
PRESSED THE 'Stop' KEY	'Stop' TUŞUNA BASILDI
THE COVER WAS OPENED	KAPAK AÇILDI
OK	TAMAM

4.2.2. General messages

ENGLISH	CZECH
CALL SERVICE 1	VOLEJTE SERVIS 1
CALL SERVICE 2	VOLEJTE SERVIS 2
CALL SERVICE 3	VOLEJTE SERVIS 3
CALL SERVICE 4	VOLEJTE SERVIS 4
CALL SERVICE 5	VOLEJTE SERVIS 5
CALL SERVICE 6	VOLEJTE SERVIS 6
CALL SERVICE 17	VOLEJTE SERVIS 17
CALL SERVICE 22	VOLEJTE SERVIS 22
CHANGE DRUM	VYMEN.FOTOVÁLEC
CHANGE TONER	VYMENTE TONER
CHECK CARTRIDGE	ZKONTR.CARTRIDGE
CHECK DOCUMENT	CHYBÍ DOKUMENT
CHECK PAPER TRAY #1	ZKONTROL. PAPÍR ZÁSOB #1
CHECK INSTALL INPUT TRAY #1	ZKONT.INSTALACI VSTUP ZÁSOB #1
CHECK PICK UP INPUT TRAY #1	ZKONT.PODÁVÁNÍ VSTUP ZÁSOB #1
CHECK REAR COVER	ZKONT.ZADNÍ KRYT
COOL DOWN FUSER PLEASE WAIT	NÍZKÁ TEPL. PECE CEKEJTE
DRUM LIFE LOW	ZIV.VÁLCE KONCÍ
DRUM LIFE OVER	ZIV.VÁLCE PREK.
EMAIL SIZE OVER	E-MAIL JE VELKY
FAX IN MEMORY	PRÍJ. DO PAMETI
FAX PREVIEW	FAX NÁHLED
FILE SIZE OVER	MOC VELKY SOUBOR
FRONT COVER OPEN	PRED.KR.OTEVREN
KEEP COPYING	KOPÍRUJE SE
LOW TEMP.	NÍZKÁ TEPLOTA
MEMORY FULL	PAMET ZAPLNENA
MODEM ERROR	CHYBA MODEMU
NO FAX REPLY	CHYBÍ ODPOVED
OUT OF PAPER INPUT TRAY #1	DOSEL PAPÍR VSTUP ZÁSOB #1
PAPER IN TRAY #2	PAPÍR V ZÁSOB #2
PAPER JAMMED	ZMACKANY PAPÍR
OPEN REAR COVER	OTEVRI ZAD. KRYT
OPEN FRONT COVER	OTEVRI PRED.KRYT
PC FAIL OR BUSY	PC CHYBA/OBSAZ.
PCFAX	PCFAX
PLEASE WAIT	CEKEJTE
POLLING ERROR	CHYBA POLLINGU
REDIAL TIME OUT	KONEC OP. VOLBY
REMOVE DOCUMENT	VYJMI DOKUMENT
REMOVE PAPER IN INPUT TRAY #2	VYJMETE PAPÍR Z VSTUP ZÁSOB #2
RX MEMORY FULL	PLNÁ PAMET PRÍJ.
SLEEP	SPÁNEK
TONER EMPTY	DOSEL TONER
TONER LIFE LOW	ZIV.TONERU KONCÍ
TONER LIFE OVER	ZIV.TONERU PREK.
TONER LOW	MÁLO TONERU
TRANSMIT ERROR	CHYBA PŘENOSU
USB MEMORY ACCESS ERROR	USB PAMET CHYBNY PŘÍSTUP
USB MEMORY FILE SIZE OVER	USB PAMET MOC VELKY SOUBOR
USB MEMORY FORMAT ERROR	USB PAMET CHYBNY FORMÁT
USB MEMORY MEDIA ERROR	USB PAMET CHYBNÉ MEDIUM
USB MEMORY NOT INSERTED	USB PAMET NENÍ VLOŽENA
USB MEMORY WRITE PROTECT	USB PAMET OCHR.PROTI ZÁPIS

ENGLISH	FRENCH
CALL SERVICE 1	CONTACTER SAV 1
CALL SERVICE 2	CONTACTER SAV 2
CALL SERVICE 3	CONTACTER SAV 3
CALL SERVICE 4	CONTACTER SAV 4
CALL SERVICE 5	CONTACTER SAV 5
CALL SERVICE 6	CONTACTER SAV 6
CALL SERVICE 17	CONTACTER SAV 17
CALL SERVICE 22	CONTACTER SAV 22
CHANGE DRUM	CHANGER TAMBOUR
CHANGE TONER	CHANGER TONER
CHECK CARTRIDGE	VÉRIF. CARTOUCHE
CHECK DOCUMENT	VÉRIFIER DOC.
CHECK PAPER TRAY #1	VÉRIFIER PAPIER BAC #1
CHECK INSTALL INPUT TRAY #1	VÉRIF.INSTAL. BAC ENTRÉE #1
CHECK PICK UP INPUT TRAY #1	VÉRIF. ENTRAÎNE. BAC ENTRÉE #1
CHECK REAR COVER	VÉRIF. CAPOT ARR
COOL DOWN FUSER PLEASE WAIT	REFROID. FUSION PATIENTEZ SVP
DRUM LIFE LOW	PRÈS FIN TAMBOUR
DRUM LIFE OVER	TAMBOUR VIDE
EMAIL SIZE OVER	E-MAIL TROP LONG
FAX IN MEMORY	FAX EN MÉMOIRE
FAX PREVIEW	APERÇU FAX
FILE SIZE OVER	FICH. TROP GROS
FRONT COVER OPEN	COUV. AVANT OUV.
KEEP COPYING	CONTINUER COPIE
LOW TEMP.	BASSE TEMP.
MEMORY FULL	MÉMOIRE PLEINE
MODEM ERROR	ERREUR MODEM
NO FAX REPLY	AUCUNE RÉPONSE
OUT OF PAPER INPUT TRAY #1	MANQUE PAPIER BAC ENTRÉE #1
PAPER IN TRAY #2	PAP. DANS BAC #2
PAPER JAMMED	BOURRAGE PAPIER
OPEN REAR COVER	OUVRIR CAPOT AR
OPEN FRONT COVER	OUV. COUV. AVANT
PC FAIL OR BUSY	PC-ÉCHEC/OCCUPÉ
PCFAX	PCFAX
PLEASE WAIT	PATIENTEZ SVP
POLLING ERROR	ERREUR RELEVÉ
REDIAL TIME OUT	FIN RECOMP.
REMOVE DOCUMENT	RETIRER DOC.
REMOVE PAPER IN INPUT TRAY #2	RETIRER PAP.DANS BAC ENTRÉE #2
RX MEMORY FULL	MÉM.RÉC.PLEINE
SLEEP	VEILLE
TONER EMPTY	TONER VIDE
TONER LIFE LOW	FIN VIE DU TONER
TONER LIFE OVER	PREV CHANG TONER
TONER LOW	TONER BAS
TRANSMIT ERROR	ERREUR ENVOI
USB MEMORY ACCESS ERROR	MEMOIRE USB ACCES IMPOSSIBLE
USB MEMORY FILE SIZE OVER	MEMOIRE USB FICH. TROP GROS
USB MEMORY FORMAT ERROR	MEMOIRE USB ERREUR FORMAT
USB MEMORY MEDIA ERROR	MEMOIRE USB ERREUR MEDIA
USB MEMORY NOT INSERTED	MEMOIRE USB NON INSÉRER
USB MEMORY WRITE PROTECT	MEMOIRE USB PROTECT ECRITURE

ENGLISH	GERMAN
CALL SERVICE 1	SERVICE ANRUFEN 1
CALL SERVICE 2	SERVICE ANRUFEN 2
CALL SERVICE 3	SERVICE ANRUFEN 3
CALL SERVICE 4	SERVICE ANRUFEN 4
CALL SERVICE 5	SERVICE ANRUFEN 5
CALL SERVICE 6	SERVICE ANRUFEN 6
CALL SERVICE 17	SERVICE ANRUFEN 17
CALL SERVICE 22	SERVICE ANRUFEN 22
CHANGE DRUM	Trommel wechseln
CHANGE TONER	Toner wechseln
CHECK CARTRIDGE	Kartusche prüfen
CHECK DOCUMENT	Dokument prüfen
CHECK PAPER TRAY #1	Papier prüfen! Fach #1
CHECK INSTALL INPUT TRAY #1	Install. Prüfen Eingabefach #1
CHECK PICK UP INPUT TRAY #1	Prüfe. Erfass. Eingabefach #1
CHECK REAR COVER	Prüfe Klappe hin
COOL DOWN FUSER PLEASE WAIT	Fixiereinh. Kühl Bitte warten
DRUM LIFE LOW	Trommel schwach
DRUM LIFE OVER	Trommelende
EMAIL SIZE OVER	E-Mail zu groß
FAX IN MEMORY	Fax im Speicher
FAX PREVIEW	FAX Vorschau
FILE SIZE OVER	Datei zu groß
FRONT COVER OPEN	Abdeck Vor Offen
KEEP COPYING	Kopiere weiter
LOW TEMP.	Niedrige Temp.
MEMORY FULL	Speicher voll!
MODEM ERROR	Modemfehler
NO FAX REPLY	Keine Faxantw.
OUT OF PAPER INPUT TRAY #1	Kein Papier Eingabefach #1
PAPER IN TRAY #2	Papier im Fach#2
PAPER JAMMED	Papierstau
OPEN REAR COVER	Hint.Abde.öffnen
OPEN FRONT COVER	Vord.Abde.öffnen
PC FAIL OR BUSY	PC Verbind.Fehl.
PCFAX	PCFAX
PLEASE WAIT	Bitte warten
POLLING ERROR	Abruf-Fehler
REDIAL TIME OUT	Wahlwdh. Zeitaus
REMOVE DOCUMENT	Dokum. entfernen
REMOVE PAPER IN INPUT TRAY #2	Entf. Papier aus Eingabefach #2
RX MEMORY FULL	Emf.Speich. voll
SLEEP	Schlafmodus
TONER EMPTY	Toner leer
TONER LIFE LOW	Bald Tonerende
TONER LIFE OVER	Tonerende
TONER LOW	Toner schwach
TRANSMIT ERROR	Übertr.
USB MEMORY ACCESS ERROR	USB Speicher Zugriffsfehler
USB MEMORY FILE SIZE OVER	USB Speicher Datei zu groß
USB MEMORY FORMAT ERROR	USB Speicher Format Fehler
USB MEMORY MEDIA ERROR	USB Speicher Media Fehler
USB MEMORY NOT INSERTED	USB Speicher Nicht eingesetzt
USB MEMORY WRITE PROTECT	USB Speicher Schreibschutz

ENGLISH	HUNGARIAN
CALL SERVICE 1	Hívd: szerviz 1
CALL SERVICE 2	Hívd: szerviz 2
CALL SERVICE 3	Hívd: szerviz 3
CALL SERVICE 4	Hívd: szerviz 4
CALL SERVICE 5	Hívd: szerviz 5
CALL SERVICE 6	Hívd: szerviz 6
CALL SERVICE 17	Hívd: szerviz 17
CALL SERVICE 22	Hívd: szerviz 22
CHANGE DRUM	Cseréljen dobot
CHANGE TONER	Festékkaz. csere
CHECK CARTRIDGE	Kazetta ellenőrz
CHECK DOCUMENT	Hiba az iratnál
CHECK PAPER TRAY #1	Papír hiba Tálca #1
CHECK INSTALL INPUT TRAY #1	Hiba a tálcánál Papírtálca #1
CHECK PICK UP INPUT TRAY #1	Papír ellenőrzés Papírtálca #1
CHECK REAR COVER	Hátsó fedél hiba
COOL DOWN FUSER PLEASE WAIT	Fixáló lehűtése Kérem, várjon
DRUM LIFE LOW	Dob élett. kevés
DRUM LIFE OVER	Dob élett. vége
EMAIL SIZE OVER	E-mail túlméret.
FAX IN MEMORY	Memóriában: fax
FAX PREVIEW	Fax nézet
FILE SIZE OVER	Túl nagy fájl
FRONT COVER OPEN	Elül.ajtó nyitva
KEEP COPYING	Másolás folyik
LOW TEMP.	Alacsony hőmérs.
MEMORY FULL	Memória megtelt
MODEM ERROR	Modem hiba
NO FAX REPLY	Fax nem felel
OUT OF PAPER INPUT TRAY #1	Papír kifogyott Papírtálca #1
PAPER IN TRAY #2	PapírtálcaHiba#2
PAPER JAMMED	Papír elakadt
OPEN REAR COVER	Nyissa:Hátsóajtó
OPEN FRONT COVER	Nyissa:Elül.ajtó
PC FAIL OR BUSY	PC hiba/foglalt
PCFAX	PCFax
PLEASE WAIT	Kérem, várjon
POLLING ERROR	Lekérdezés hiba
REDIAL TIME OUT	Újrahívás vége
REMOVE DOCUMENT	Iratot vegye ki
REMOVE PAPER IN INPUT TRAY #2	Vegye ki : papír Papírtálca #2
RX MEMORY FULL	Vételi mem. tele
SLEEP	Alvó üzemmód
TONER EMPTY	Nincs festék
TONER LIFE LOW	Élettartam kevés
TONER LIFE OVER	Élettartam vége
TONER LOW	Festék fogyóban
TRANSMIT ERROR	Átviteli hiba
USB MEMORY ACCESS ERROR	USB memória Hozzáférés hiba
USB MEMORY FILE SIZE OVER	USB memória Túl nagy fájl
USB MEMORY FORMAT ERROR	USB memória Formátum hiba
USB MEMORY MEDIA ERROR	USB memória Média hiba
USB MEMORY NOT INSERTED	USB memória nincs behelyezve
USB MEMORY WRITE PROTECT	USB memória Írásvédelem

ENGLISH	POLISH
CALL SERVICE 1	WEZWIJ SERWIS 1
CALL SERVICE 2	WEZWIJ SERWIS 2
CALL SERVICE 3	WEZWIJ SERWIS 3
CALL SERVICE 4	WEZWIJ SERWIS 4
CALL SERVICE 5	WEZWIJ SERWIS 5
CALL SERVICE 6	WEZWIJ SERWIS 6
CALL SERVICE 17	WEZWIJ SERWIS 17
CALL SERVICE 22	WEZWIJ SERWIS 22
CHANGE DRUM	WYMIEN BEBEN
CHANGE TONER	WYMIEN TONER
CHECK CARTRIDGE	SPRAWDŹ KARTRIDŹ
CHECK DOCUMENT	SPRAWDZ DOK.
CHECK PAPER TRAY #1	SPRAWDZ PAPIER POD. #1
CHECK INSTALL INPUT TRAY #1	SPRAWDZ PODAJNIK PAP.#1
CHECK PICK UP INPUT TRAY #1	BLOKADA PAPIERU PODAJNIK PAP.#1
CHECK REAR COVER	SPR.TYL.POKRYWĘ
COOL DOWN FUSER PLEASE WAIT	CHŁODZ.UTRWAL. PROSZE CZEKAC
DRUM LIFE LOW	BEBEN MOC.ZUŻYTY
DRUM LIFE OVER	BEBEN ZUŻYTY
EMAIL SIZE OVER	E-MAIL ZA DUŻY
FAX IN MEMORY	DOK. W PAMIĘCI
FAX PREVIEW	PODGLĄD FAX
FILE SIZE OVER	PLIK ZA DUŻY
FRONT COVER OPEN	POKR.PRZED.OTWAR
KEEP COPYING	KOPIUJ
LOW TEMP.	NISKA TEMP.
MEMORY FULL	PAMIĘĆ PEŁNA
MODEM ERROR	BŁĄD MODEMU
NO FAX REPLY	NIE POL.Z FAKSEM
OUT OF PAPER INPUT TRAY #1	BRĄK PAPIERU PODAJNIK PAP.#1
PAPER IN TRAY #2	PAP.W PODAJNIKU2
PAPER JAMMED	BLOKADA PAPIERU
OPEN REAR COVER	OTWÓRZ TYLNĄ POK
OPEN FRONT COVER	OTWÓRZ PRZED.POK
PC FAIL OR BUSY	PC-BŁĄD LUB ZAJ
PCFAX	PCFAX
PLEASE WAIT	PROSZE CZEKAC
POLLING ERROR	BŁĄD POLLINGU
REDIAL TIME OUT	POWT.WYB-KONIEC
REMOVE DOCUMENT	USUN DOKUMENT
REMOVE PAPER IN INPUT TRAY #2	USUŃ PAPIER PODAJNIK PAP.#2
RX MEMORY FULL	PAMIĘĆ ODB.PEŁNA
SLEEP	STAN UŚPIENIA
TONER EMPTY	BRĄK TONERA
TONER LIFE LOW	TONER MOC.ZUŻYTY
TONER LIFE OVER	TONER ZUŻYTY
TONER LOW	MAŁO TONERA
TRANSMIT ERROR	BŁĄD TRANSMISJI
USB MEMORY ACCESS ERROR	PAMIĘĆ USB BŁĄD DOSTĘPU
USB MEMORY FILE SIZE OVER	PAMIĘĆ USB PLIK ZA DUŻY
USB MEMORY FORMAT ERROR	PAMIĘĆ USB BŁĄD FORMATU
USB MEMORY MEDIA ERROR	PAMIĘĆ USB BŁĄD PAMIĘCI USB
USB MEMORY NOT INSERTED	PAMIĘĆ USB NIEWŁĄCZONA
USB MEMORY WRITE PROTECT	PAMIĘĆ USB ZAPIS ZABRONIONY

ENGLISH	PORTUGUESE
CALL SERVICE 1	CHAME TÉCNICO 1
CALL SERVICE 2	CHAME TÉCNICO 2
CALL SERVICE 3	CHAME TÉCNICO 3
CALL SERVICE 4	CHAME TÉCNICO 4
CALL SERVICE 5	CHAME TÉCNICO 5
CALL SERVICE 6	CHAME TÉCNICO 6
CALL SERVICE 17	CHAME TÉCNICO 17
CALL SERVICE 22	CHAME TÉCNICO 22
CHANGE DRUM	SUBST TAMBOR
CHANGE TONER	SUBSTIT. TONER
CHECK CARTRIDGE	VERIF. CONSUMIV.
CHECK DOCUMENT	VERIFIQUE DOC.
CHECK PAPER TRAY #1	VERIFIQUE PAPEL TAB. #1
CHECK INSTALL INPUT TRAY #1	VERIF.TABULEIRO TABULEIRO #1
CHECK PICK UP INPUT TRAY #1	VERIF.ALIM.PAPEL TABULEIRO #1
CHECK REAR COVER	VERIF.TAMP. TRAS.
COOL DOWN FUSER PLEASE WAIT	FUSOR A ARREFEC. AGUARDE P.FAVOR
DRUM LIFE LOW	DUR.TAMBOR BAIXA
DRUM LIFE OVER	TERM.VIDA TAMBOR
EMAIL SIZE OVER	TAM.E-MAIL EXCE.
FAX IN MEMORY	DOC.NA MEMÓRIA
FAX PREVIEW	VISUALIZAR FAX
FILE SIZE OVER	DEMASIADO GRANDE
FRONT COVER OPEN	TAMPA FRT.ABERTA
KEEP COPYING	CONTINUE COPIAR
LOW TEMP.	TEMP. BAIXA
MEMORY FULL	MEMÓRIA CHEIA
MODEM ERROR	ERRO MODEM
NO FAX REPLY	SEM RESPOSTA
OUT OF PAPER INPUT TRAY #1	SEM PAPEL TABULEIRO #1
PAPER IN TRAY #2	PAPEL NO TAB. #2
PAPER JAMMED	PAPEL ENCRAVADO
OPEN REAR COVER	ABRA TAMPA TRÁS
OPEN FRONT COVER	ABRA TAMPA FRNT.
PC FAIL OR BUSY	FALHA PC/OCUP.
PCFAX	PC-FAX
PLEASE WAIT	AGUARDE P.FAVOR
POLLING ERROR	ERRO AO PUXAR
REDIAL TIME OUT	FIM REPETIÇÃO
REMOVE DOCUMENT	RETIRE DOC.
REMOVE PAPER IN INPUT TRAY #2	RETIRE PAPEL TABULEIRO #2
RX MEMORY FULL	MEM.RECEP.CHEIA
SLEEP	MODO DORMIR
TONER EMPTY	TONER VAZIO
TONER LIFE LOW	TONER BAIXO
TONER LIFE OVER	TONER TERMINOU
TONER LOW	FALTA TONER
TRANSMIT ERROR	ERRO TRANSM.
USB MEMORY ACCESS ERROR	USB MEMÓRIA ERRO ACESSO
USB MEMORY FILE SIZE OVER	USB MEMÓRIA DEMASIADO GRANDE
USB MEMORY FORMAT ERROR	USB MEMÓRIA ERRO FORMATO
USB MEMORY MEDIA ERROR	USB MEMÓRIA ERRO DE MÍDIA
USB MEMORY NOT INSERTED	USB MEMÓRIA NÃO INSERIDO
USB MEMORY WRITE PROTECT	USB MEMÓRIA PROTEC. ESCRITA

ENGLISH	SLOVAK
CALL SERVICE 1	VOLAJTE SERVIS 1
CALL SERVICE 2	VOLAJTE SERVIS 2
CALL SERVICE 3	VOLAJTE SERVIS 3
CALL SERVICE 4	VOLAJTE SERVIS 4
CALL SERVICE 5	VOLAJTE SERVIS 5
CALL SERVICE 6	VOLAJTE SERVIS 6
CALL SERVICE 17	VOLAJTE SERVIS 17
CALL SERVICE 22	VOLAJTE SERVIS 22
CHANGE DRUM	VYMENTE VALEC
CHANGE TONER	VYMENTE TONER
CHECK CARTRIDGE	SKONTR.CARTRIDGE
CHECK DOCUMENT	VLOZTE DOKUMENT
CHECK PAPER TRAY #1	SKONTR.PAPIER ZÁSOB 1
CHECK INSTALL INPUT TRAY #1	SKONTR.ZÁSOBNÍK ZÁSOBNÍK C.1
CHECK PICK UP INPUT TRAY #1	SKONTR.PODAVANIE ZÁSOBNÍK C.1
CHECK REAR COVER	SKONTR.ZAD.KRYT
COOL DOWN FUSER PLEASE WAIT	CHLADENIE ČAKAJTE,PROSÍM
DRUM LIFE LOW	VALEC DOSLUHUJE
DRUM LIFE OVER	VALEC OPOTREBOV.
EMAIL SIZE OVER	SCHRÁNKA JE PLNÁ
FAX IN MEMORY	FAX V PAMATI
FAX PREVIEW	FAX NÁHLAD
FILE SIZE OVER	VELKY SUBOR<20MB
FRONT COVER OPEN	PRED.KRYT OTVORE
KEEP COPYING	DALSIE KOPIROV.
LOW TEMP.	NIZKA TEPLOTA
MEMORY FULL	PLNÁ PAMÄT
MODEM ERROR	PORUCHA MODEMU
NO FAX REPLY	FAX NEPRIJATY
OUT OF PAPER INPUT TRAY #1	MINUL SA PAPIER ZÁSOBNÍK C.1
PAPER IN TRAY #2	PAPIER V ZÁS.C.2
PAPER JAMMED	UVIAZOL PAPIER
OPEN REAR COVER	OTVOR ZAD. KRYT
OPEN FRONT COVER	OTVOR PRED.KRYT
PC FAIL OR BUSY	CHYBA PC
PCFAX	PCFAX
PLEASE WAIT	ČAKAJTE,PROSÍM
POLLING ERROR	CHYBA POLLINGU
REDIAL TIME OUT	OPAK.VOLBA-STOP
REMOVE DOCUMENT	VYBERTE DOKUM.
REMOVE PAPER IN INPUT TRAY #2	VYBER.PAP.ZÁSOB.ZÁSOBNÍK C.2
RX MEMORY FULL	PAMAT PRIJ.PLNA
SLEEP	SPANOK
TONER EMPTY	MINUTY TONER
TONER LIFE LOW	TONER DOSLUHUJE
TONER LIFE OVER	TONER OPOTREBOV.
TONER LOW	MALO TONERA
TRANSMIT ERROR	CHYBA PRENOSU
USB MEMORY ACCESS ERROR	USB PAMAT CHYBA PRÍSTUP
USB MEMORY FILE SIZE OVER	USB PAMAT VELKY SUBOR<20MB
USB MEMORY FORMAT ERROR	USB PAMAT CHYBA FORMAT
USB MEMORY MEDIA ERROR	USB PAMAT CHYBA MEDIA
USB MEMORY NOT INSERTED	USB PAMAT NIE JE VLOZENÁ
USB MEMORY WRITE PROTECT	USB PAMAT OCHR.PROTI ZÁPIS

ENGLISH	SPANISH
CALL SERVICE 1	LLAME AL SAT 1
CALL SERVICE 2	LLAME AL SAT 2
CALL SERVICE 3	LLAME AL SAT 3
CALL SERVICE 4	LLAME AL SAT 4
CALL SERVICE 5	LLAME AL SAT 5
CALL SERVICE 6	LLAME AL SAT 6
CALL SERVICE 17	LLAME AL SAT 17
CALL SERVICE 22	LLAME AL SAT 22
CHANGE DRUM	SUST TAMBOR
CHANGE TONER	SUSTITUIR TONER
CHECK CARTRIDGE	VERIF. CARTUCHO
CHECK DOCUMENT	VERIF.DOCUMENTO
CHECK PAPER TRAY #1	REVISAR PAPEL BAND. #1
CHECK INSTALL INPUT TRAY #1	VERIFI.INSTALAC.BAND.ENTRADA #1
CHECK PICK UP INPUT TRAY #1	VERIF.INTR.PAPEL BAND.ENTRADA #1
CHECK REAR COVER	REVISE TAPA POST
COOL DOWN FUSER PLEASE WAIT	ENFRIANDO FUSOR ESPERE
DRUM LIFE LOW	TAMBOR NIV. BAJO
DRUM LIFE OVER	TAMBOR AGOTADO
EMAIL SIZE OVER	MEMO EMAIL LLENA
FAX IN MEMORY	FAX EN MEMORIA
FAX PREVIEW	VISTA PREVIA FAX
FILE SIZE OVER	ARCHI. MUYGRANDE
FRONT COVER OPEN	TAPA FRO ABIERTA
KEEP COPYING	SALVAR COPIADO
LOW TEMP.	TEMPERATURA BAJA
MEMORY FULL	MEMORIA LLENA
MODEM ERROR	ERROR EN MODEM
NO FAX REPLY	NO RESPONDE FAX
OUT OF PAPER INPUT TRAY #1	FALTA PAPEL BAND. ENTRADA #1
PAPER IN TRAY #2	PAPEL EN BAND #2
PAPER JAMMED	ATASCO PAPEL
OPEN REAR COVER	ABRIR TAPA TRAS.
OPEN FRONT COVER	ABRIR TAPA FRONT
PC FAIL OR BUSY	PC OCUPAD/FALLO
PCFAX	PCFAX
PLEASE WAIT	ESPERE
POLLING ERROR	ERROR POLLING
REDIAL TIME OUT	FIN RELAMADA
REMOVE DOCUMENT	SAQUE DOCUMENTO
REMOVE PAPER IN INPUT TRAY #2	QUITAR PAPEL BAND.ENTRADA #2
RX MEMORY FULL	MEMORIA RX LLENA
SLEEP	AHORRO ENERGÍA
TONER EMPTY	TONER VACIO
TONER LIFE LOW	NIVEL BAJO TONER
TONER LIFE OVER	TONER AGOTADO
TONER LOW	TONER BAJO
TRANSMIT ERROR	ERROR TRANS.
USB MEMORY ACCESS ERROR	MEMORIA USB ERROR ACCESO
USB MEMORY FILE SIZE OVER	MEMORIA USB ARCHI.MUYGRANDE
USB MEMORY FORMAT ERROR	MEMORIA USB ERROR FORMATO
USB MEMORY MEDIA ERROR	MEMORIA USB MEDIA ERROR
USB MEMORY NOT INSERTED	MEMORIA USB NO INSERTADA
USB MEMORY WRITE PROTECT	MEMORIA USB ESCRITURA PROTEG

ENGLISH	TURKISH
CALL SERVICE 1	SERVİSİ ARAYIN 1
CALL SERVICE 2	SERVİSİ ARAYIN 2
CALL SERVICE 3	SERVİSİ ARAYIN 3
CALL SERVICE 4	SERVİSİ ARAYIN 4
CALL SERVICE 5	SERVİSİ ARAYIN 5
CALL SERVICE 6	SERVİSİ ARAYIN 6
CALL SERVICE 17	SERVİSİ ARAYIN 17
CALL SERVICE 22	SERVİSİ ARAYIN 22
CHANGE DRUM	DRUM DEĞİŞTİR
CHANGE TONER	TONER DEĞİŞTİR
CHECK CARTRIDGE	KARTUŞ KONTROL
CHECK DOCUMENT	DÖKÜMAN YOK
CHECK PAPER TRAY #1	KAĞIDI KONT.EDİN KASET #1
CHECK INSTALL INPUT TRAY #1	KASET KONTROL ET KAĞIT HAZNESİ #1
CHECK PICK UP INPUT TRAY #1	KAĞIDI KONTROL ET KAĞIT HAZNESİ #1
CHECK REAR COVER	ARKA KAPAK KONT.
COOL DOWN FUSER PLEASE WAIT	FÜZER SOĞUYOR LÜT. BEKLEYİN
DRUM LIFE LOW	DRUM ÖMRÜ DÜŞÜK
DRUM LIFE OVER	DRUM ÖMRÜ AŞILDI
EMAIL SIZE OVER	E-POSTA BÜYÜK
FAX IN MEMORY	HAFIZADA MSJ.VAR
FAX PREVIEW	FAKS ÖNİZLEME
FILE SIZE OVER	DOSYA COK BUYUK
FRONT COVER OPEN	ÖN KAPAK AÇIK
KEEP COPYING	KOPYA SAKLAMAK
LOW TEMP.	DÜŞÜK ISI
MEMORY FULL	BELLEK DOLU
MODEM ERROR	MODEM HATASI
NO FAX REPLY	CEVAP VERMİYOR
OUT OF PAPER INPUT TRAY #1	KAĞIT YOK KAĞIT HAZNESİ #1
PAPER IN TRAY #2	KAĞIDI ALIN #2
PAPER JAMMED	KAĞIT SIKIŞTI
OPEN REAR COVER	ARKA KAPAĞI AÇ
OPEN FRONT COVER	ÖN KAPAĞI AÇIN
PC FAIL OR BUSY	PC HATASI/MEŞG.
PCFAX	PCFAKS
PLEASE WAIT	LÜT. BEKLEYİN
POLLING ERROR	POLLING HATASI
REDIAL TIME OUT	ARAMA BİTTİ
REMOVE DOCUMENT	KAĞIDI ÇIKARIN
REMOVE PAPER IN INPUT TRAY #2	KAĞIDI ÇIKAR KAĞIT HAZNESİ #2
RX MEMORY FULL	RX HAFIZA DOLU
SLEEP	UYKU
TONER EMPTY	TONER BİTTİ
TONER LIFE LOW	TONER ÖMRÜ DÜŞÜK
TONER LIFE OVER	TONER BİTİYOR
TONER LOW	TONER AZALDI
TRANSMIT ERROR	GÖNDERİM HATASI
USB MEMORY ACCESS ERROR	USB HAFIZA BAĞLANTI HATASI
USB MEMORY FILE SIZE OVER	USB HAFIZA DOSYA COK BUYUK
USB MEMORY FORMAT ERROR	USB HAFIZA FORMAT HATASI
USB MEMORY MEDIA ERROR	USB HAFIZA DOSYA HATASI
USB MEMORY NOT INSERTED	USB HAFIZA TAKILMADI
USB MEMORY WRITE PROTECT	USB HAFIZA KAYIT HATASI

4.2.3. Interface messages

ENGLISH	CZECH
CONNECT ERROR	CHYBA PRIPOJENÍ
DATA ERROR	CHYBA DAT
EMAIL SIZE OVER	MAIL JE VELKY
FILE SIZE OVER	MOC VELKY SOUBOR
LOGIN ERROR	CHYBA PRIHLÁSENÍ
NAME ERROR	CHYBNÉ JMÉNO
OFFLINE	OFFLINE
PATH ERROR	CHYBNÁ CESTA
PC ACCESS ERROR	CHYBA PC PŘÍSTUP
PC FAIL OR BUSY	PC CHYBA/OBSAZ.

ENGLISH	FRENCH
CONNECT ERROR	ERREUR CONNEXION
DATA ERROR	ERREUR DONNÉES
EMAIL SIZE OVER	E-MAIL TROP LONG
FILE SIZE OVER	FICH. TROP GROS
LOGIN ERROR	ERREUR LOGIN
NAME ERROR	ERREUR DE NOM
OFFLINE	OFF-LINE
PATH ERROR	ERREUR CHEMIN
PC ACCESS ERROR	ERR. D'ACCÈS PC
PC FAIL OR BUSY	PC-ÉCHEC/OCCUPÉ

ENGLISH	GERMAN
CONNECT ERROR	Verbindungsfehler
DATA ERROR	Datenfehler
EMAIL SIZE OVER	E-Mail zu groß
FILE SIZE OVER	Datei zu groß
LOGIN ERROR	Login-Fehler
NAME ERROR	Fehlerbezeichnung
OFFLINE	Off-Line
PATH ERROR	Fehlerhaft.Pfad
PC ACCESS ERROR	PC-Zugriffsfehl.
PC FAIL OR BUSY	PC Verbind.Fehl.

ENGLISH	HUNGARIAN
CONNECT ERROR	Csatlakozás hiba
DATA ERROR	Adat hiba
EMAIL SIZE OVER	E-mail túlméret.
FILE SIZE OVER	Túl nagy fájl
LOGIN ERROR	Bejelentkez.hiba
NAME ERROR	Név hiba
OFFLINE	Kapcsolat nélkül
PATH ERROR	Elérési út hiba
PC ACCESS ERROR	PC elérési hiba
PC FAIL OR BUSY	PC hiba/foglalt

ENGLISH	POLISH
CONNECT ERROR	BŁĄD POŁĄCZENIA
DATA ERROR	BŁĄD KOMUNIKACJI
EMAIL SIZE OVER	E-MAIL ZA DUŻY
FILE SIZE OVER	PLIK ZA DUŻY
LOGIN ERROR	BŁĄD LOGOWANIA
NAME ERROR	BŁĘDNA NAZWA
OFFLINE	OFFLINE
PATH ERROR	BŁĄD ŚCIEŻKI DOS
PC ACCESS ERROR	BŁĄD DOST.DO PC
PC FAIL OR BUSY	PC-BŁĄD LUB ZAJ

ENGLISH	PORTUGUESE
CONNECT ERROR	ERRO DE CONEXÃO
DATA ERROR	ERRO DE DADOS
EMAIL SIZE OVER	TAM.E-MAIL EXCE.
FILE SIZE OVER	DEMASIADO GRANDE
LOGIN ERROR	ERRO DE LOGIN
NAME ERROR	ERRO NO NOME
OFFLINE	SEM-CONEXÃO
PATH ERROR	ERRO NO CAMINHO
PC ACCESS ERROR	ERRO ACESSO PC
PC FAIL OR BUSY	FALHA PC/OCUP.

ENGLISH	SLOVAK
CONNECT ERROR	CHYBA PRIPOJENIA
DATA ERROR	CHYBA DATA
EMAIL SIZE OVER	SCHRÁNKA JE PLNÁ
FILE SIZE OVER	VELKY SUBOR<20MB
LOGIN ERROR	CHYBA PRIHLAS.
NAME ERROR	CHYBA MENO
OFFLINE	OFFLINE
PATH ERROR	CHYBNA CESTA
PC ACCESS ERROR	CHYBA PC PRIPOJ.
PC FAIL OR BUSY	CHYBA PC

ENGLISH	SPANISH
CONNECT ERROR	ERROR CONEXIÓN
DATA ERROR	ERROR DE DATOS
EMAIL SIZE OVER	MEMO EMAIL LLENA
FILE SIZE OVER	ARCHI. MUYGRANDE
LOGIN ERROR	ERROR REGISTRO
NAME ERROR	ERROR DE NOMBRE
OFFLINE	FUERA DE LÍNEA
PATH ERROR	ERROR DE RUTA
PC ACCESS ERROR	ERROR ACCESO PC
PC FAIL OR BUSY	PC OCUPAD/FALLO

ENGLISH	TURKISH
CONNECT ERROR	BAĞLANTI HATASI
DATA ERROR	DATA HATASI
EMAIL SIZE OVER	E-POSTA BÜYÜK
FILE SIZE OVER	DOSYA COK BUYUK
LOGIN ERROR	GİRİŞ HATASI
NAME ERROR	AD HATASI
OFFLINE	BAĞLANTI YOK
PATH ERROR	YOL HATASI
PC ACCESS ERROR	PC BAĞLANTI HATA
PC FAIL OR BUSY	PC HATASI/MEŞG.

5 Features

5.1. General Features

General

LCD (Liquid Crystal Display) readout

Flat-Bed Multifunction Laser Fax

Letter/A4/Legal, G3 compatible

Automatic document feeder (50 sheets)

Resolution: Standard/Fine/Super fine/Photo (64 level).

STANDARD: For printed or typewritten originals with normal-sized characters.

FINE: For originals with small printing.

SUPER FINE: For originals with very small printing.

PHOTO: For originals containing photographs, shaded drawing, etc.

500-sheet paper capacity (64 g/m² ~ 75 g/m²)

Large Memory... Performed by DRAM

KX-MB2230/KX-MB2270

Approx. 80 pages of memory reception

Approx. 150 pages of memory transmission

KX-MB2545/KX-MB2575

Approx. 350 pages of memory reception

Approx. 200 pages of memory transmission

DP-MB310

Approx. 400 pages of memory reception

Approx. 200 pages of memory transmission

Enhanced Copier Function

Multi-copy function (up to 99 copies)

Enlargement and reduction

64-Level halftone

5.2. Hardware Requirements for Multi-Function Software

To use Multi-Function Station on your computer, the following are required:

Operating System:

Windows 7 / Windows 8 / Windows XP / Windows Vista

Windows Server 2008 / 2012 *1

Mac OS X 10.5 - 10.8 *2

*1 Supported printer driver only

*2 Supported printer driver, scanner driver and PC fax (transmit) only

CPU:

Windows:

Windows 7 / Windows 8 / Windows Vista: Pentium 4 or higher processor

Windows XP: Pentium III or higher processor

Mac OS:

Complies with Operating System recommendations

RAM:

Windows:

Windows 7 / Windows 8: 1GB (2GB or more recommended)

Windows XP: 128MB (256MB or more recommended)

Windows Vista: 512MB (1GB or more recommended)

Mac OS:

Complies with Operating System recommendations

Other Hardware:

CD-ROM drive

Windows:

Hard disk drive with at least 600MB of available space

Mac OS:

Hard disk drive with at least 200MB of available space

Web browser (recommendation):

Windows:

Windows Internet Explorer 6/7/8/9

Windows Internet Explorer 10 (with compatible mode recommended)

Mac OS:

Safari 3/4/5/6

6 Technical Descriptions

6.1. Connection Diagram

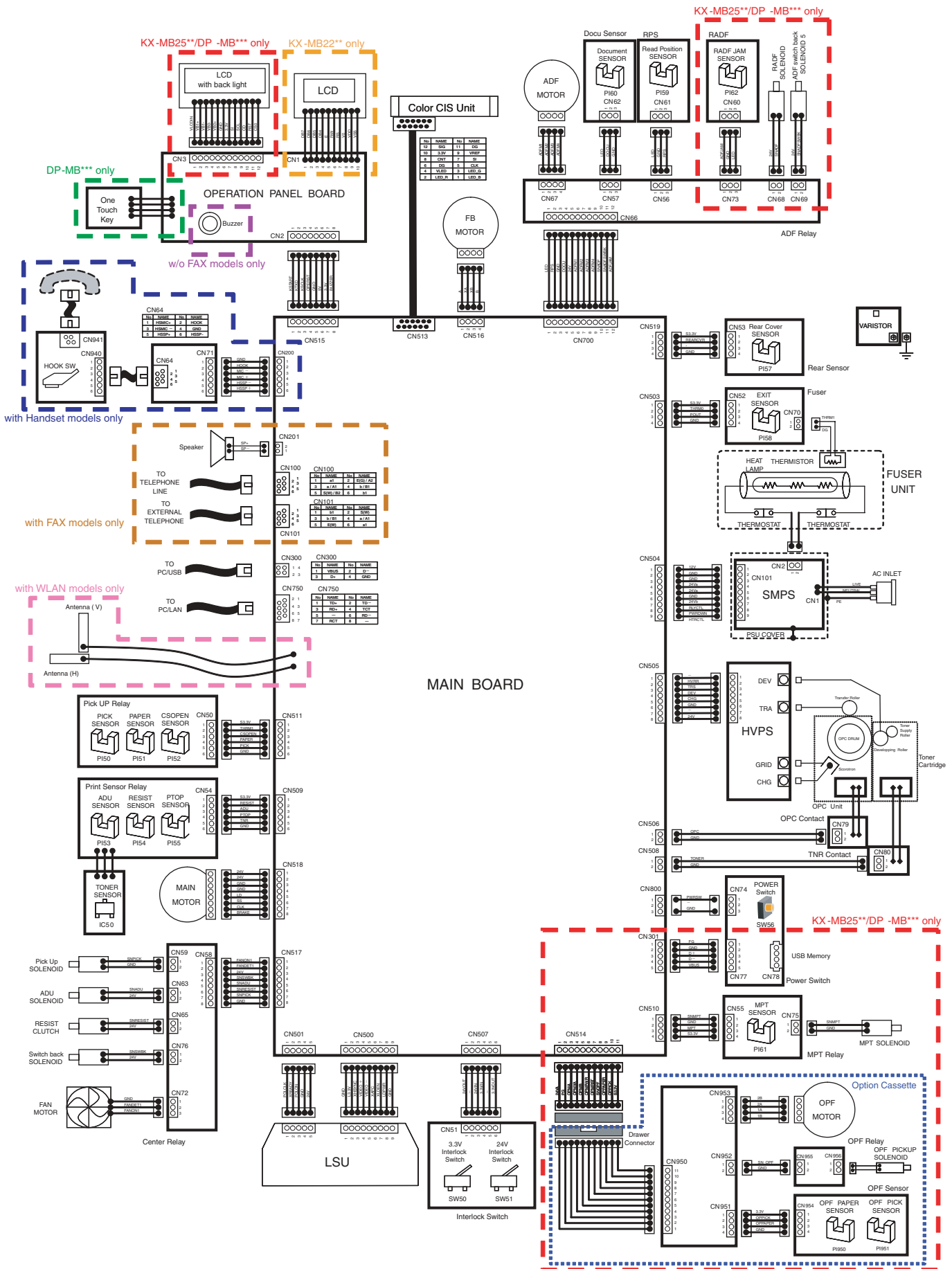

6.2. General Block Diagram

MAIN Board SOC (IC300)

This custom IC is used for general MFP operations.

- | | | |
|-----|-------------------------|---|
| 1) | CPU | ARM9 operating at 250MHz. |
| 2) | SDRAM Controller | Controls SDRAM Memory. |
| 3) | USB Controller with PHY | ch1:USB device (Apply to USB2.0HS)
ch2:USB host (Interface with WLAN IC) (KX-MB2*7* ONLY)
ch3:USB host (USB memory) (KX-MB25**/DP-MB*** ONLY) |
| 4) | Scanner I/F | Controls the CIS and AFE, and process the scan images. |
| 5) | LSU I/F | Controls the polygon motor and outputs the VIDEO signal to LSU. |
| 6) | MOTOR I/F | Controls DC motor and Stepping motor. |
| 7) | FAN I/F | Controls FAN MOTOR and detect the rotation of FAN MOTOR. |
| 8) | OPERATION PANEL I/F | Serial interface with Operation Panel. |
| 9) | SENSOR I/F | Detects the sensor signal. |
| 10) | I/O PORT | I/O Port Interface. |
| 11) | A/D, D/A converter | Sends beep tones, etc.
Convert the analog signal to the digital signal. |
| 12) | RTC | Real time clock. |
| 13) | MODEM | Performs the modulation and the demodulation for FAX communication.
(except KX-MB2*1*) |
| 14) | Analog Front End I/F | Controls the DAA device for TEL/FAX function.
(except KX-MB2*1*) |
| 15) | LAN Controller | Ethernet control. |

ROM (IC402) (KX-MB22*0:8MB, others:16MB)

This FLASH ROM contains all of the program instructions on the unit operations.
And support the backup of user setting and FAX receive data. (except KX-MB2*1*)

Synchronous Dynamic RAM (IC400/IC401)

This 512Mbit SDRAM is used for CPU work and receiving memory and page memory.

POWER SUPPLY

DC-DC converters generate 3.3V and 1.2V for system power.
Regulator generates 5V for system power and 2.5V for SPT IC power.

TEL/FAX I/F (except KX-MB2*1*)

Composed of ITS circuit and NCU circuit.
3 ICs called SDAA (Silicon Direct Access Arrangement) control Telephone line, Speaker and MIC.

ASIC(SPT,IC500)

This custom IC is used for laser control.

Wireless LAN module(IC850) (KX-MB2*7* ONLY)

Apply to IEEE802.11b/g/n.

READ Section

CIS Unit to read transmitted documents.
Scan data is converted by AFE(IC503).

Motor

This model has 2 stepping motors and one DC motor.
IC502 drives the stepping motors for CIS carriage and Auto Document Feeder.
Main Motor is a DC motor.

LSU

Forms the images on the OPC DRUM by rotating polygon motor and reflecting the laser beam against polygon.

Sensors

This model has :
2 switches and 11 sensors for KX-MB22**.
2 switch and 13 sensors for KX-MB25**/DP-MB***.

Low Voltage Power Supply Board (SMPS Board)

Supplies +24V and +12V to the Main unit and controls the Heat Lamp.

High Voltage Power Supply Board (HVPS Board)

Supplies bias need for the printing operation: bias of the DRUM, Developing and Transcription.

Fuser Unit

Composed heat lamp, thermistor and thermostats.

FAN MOTOR

FAN motor cool down Fuse Unit.

Solenoid

This model has :

4 solenoids for KX-MB22**.

7 solenoids for KX-MB25**/DP-MB***.

OPTIONAL LOWER INPUT TRAY Interface

Only KX-MB25**/DP-MB*** has the connector to Optional Lower Input Tray.

MB2200/MB2500 series System Schematic

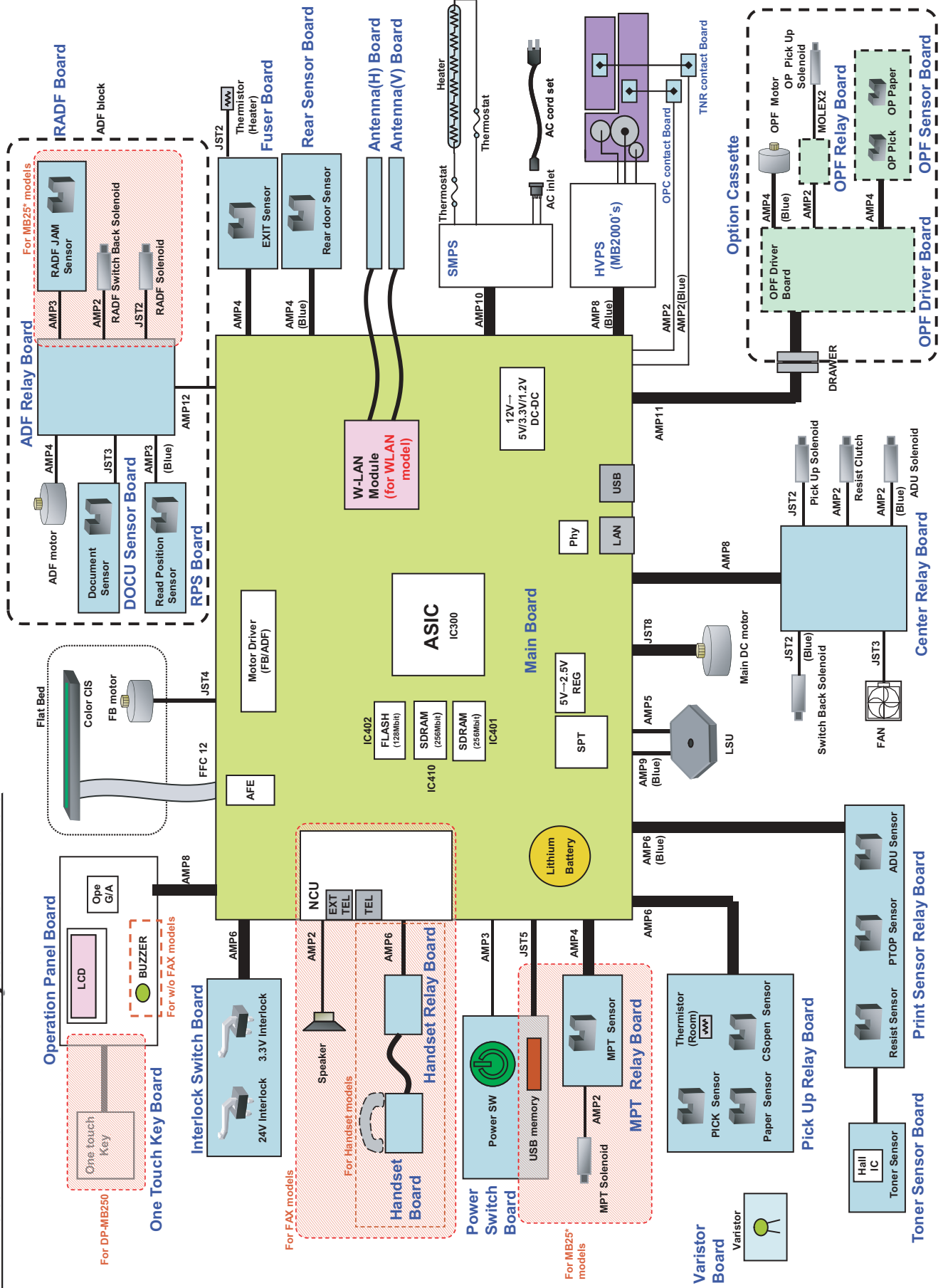

6.3. Main Board Section

6.3.1. Data Flow

[Copy]

1. An analog image data is output from CIS unit to IC503.
IC503 decode the analog data to digital data, and output to IC300.
Scanner I/F in IC300 process image data and store it in IC400/401 through SDRAM I/F.
2. If necessary, the data is compressed/decompressed via JBIG.
3. Print I/F retrieve the data from IC400/401 and output it to LSU.

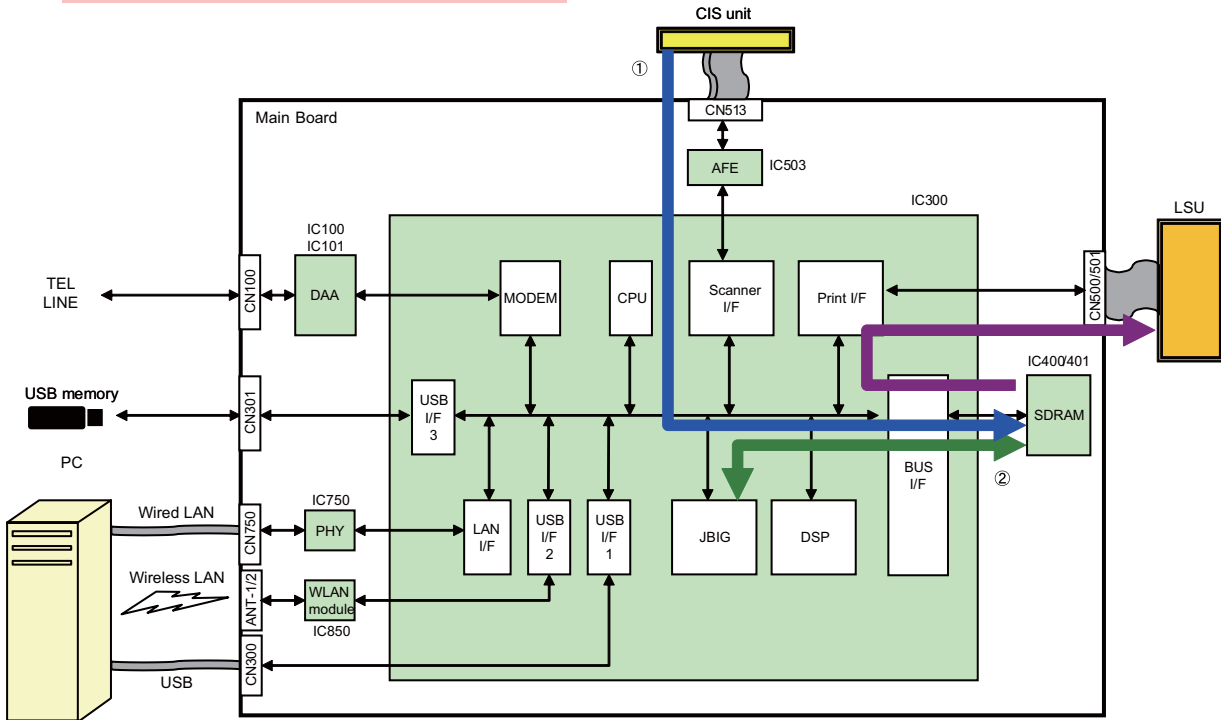

[FAX Tx]

※MB221x, MB251x is excludes.

1. An analog image data is output from CIS unit to IC503. IC503 decode the analog data to digital data, and output to IC300. Scanner I/F in IC300 process image data and store it in IC400/401 through SDRAM I/F.
2. CPU compress the data in IC400/401.
3. CPU transfer the data to MODEM and output it to TEL LINE through DAA circuit.

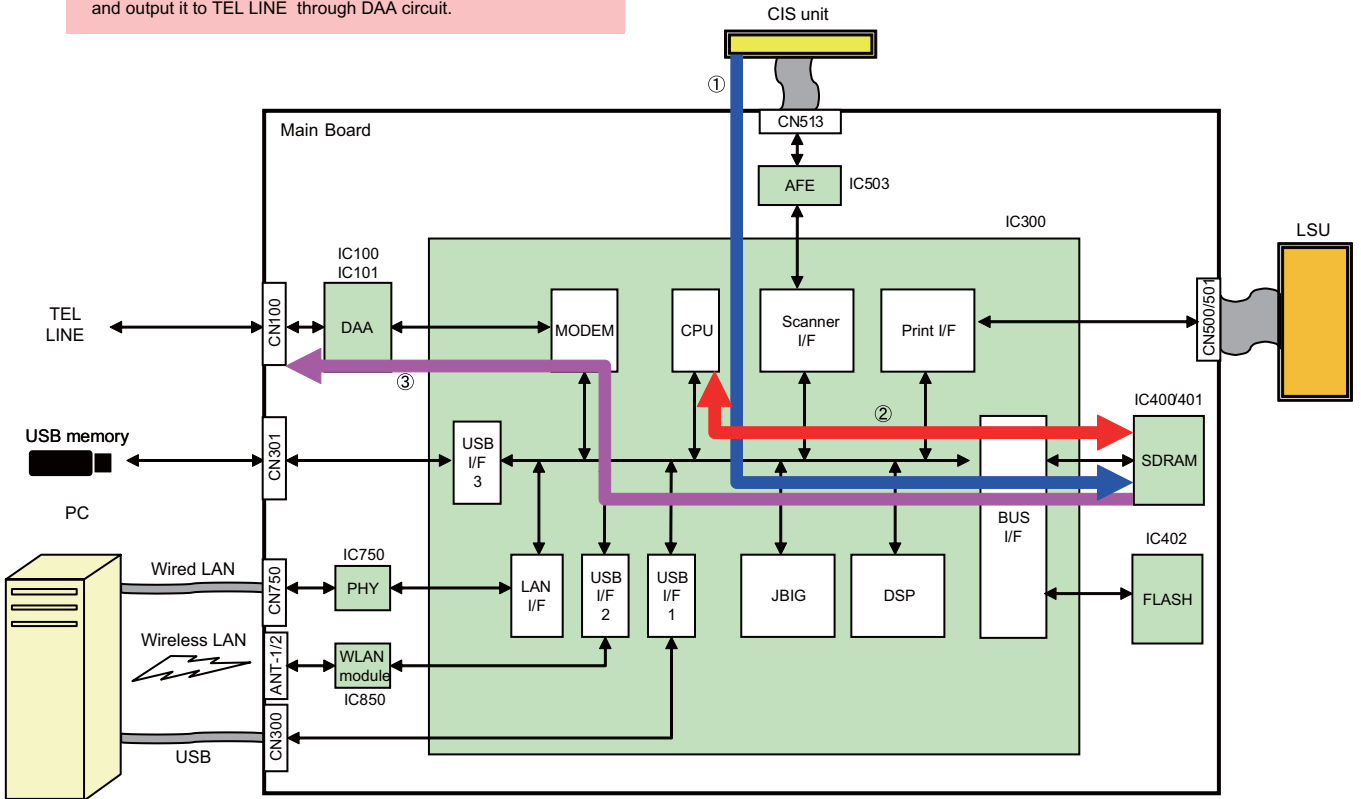

[FAX Rx]

※MB221x, MB251x is excludes.

1. FAX data is input from TEL LINE to MODEM in IC300 through DAA circuit. And then store it in IC402.
2. CPU decompress the data from IC402 to IC400/401.
3. Print I/F retrieve the data from IC400/401 and output it to LSU.

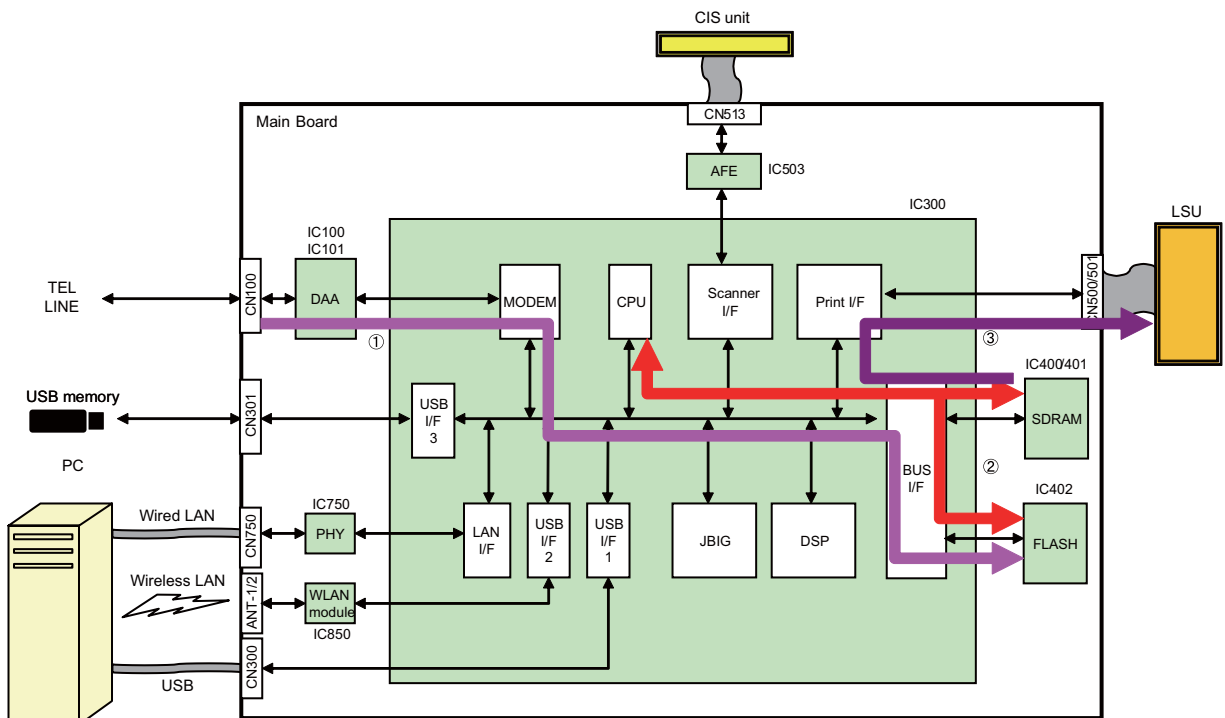

[PC Scan]

1. An analog image data is output from CIS unit to IC503.
IC503 decode the analog data to digital data, and output to IC300.
Scanner I/F in IC300 process image data and store it in IC400/401 through SDRAM I/F.
2. If necessary, DSP process image data.
3. 1. When you use the wired-LAN,
the data is output to PC through the LAN I/F and PHY(IC750).
2. When you use the wireless-LAN, the data is output to PC through the USB I/F2 and WLAN module(IC850).
3. When you use the USB, the data is output to PC through the USB I/F1.

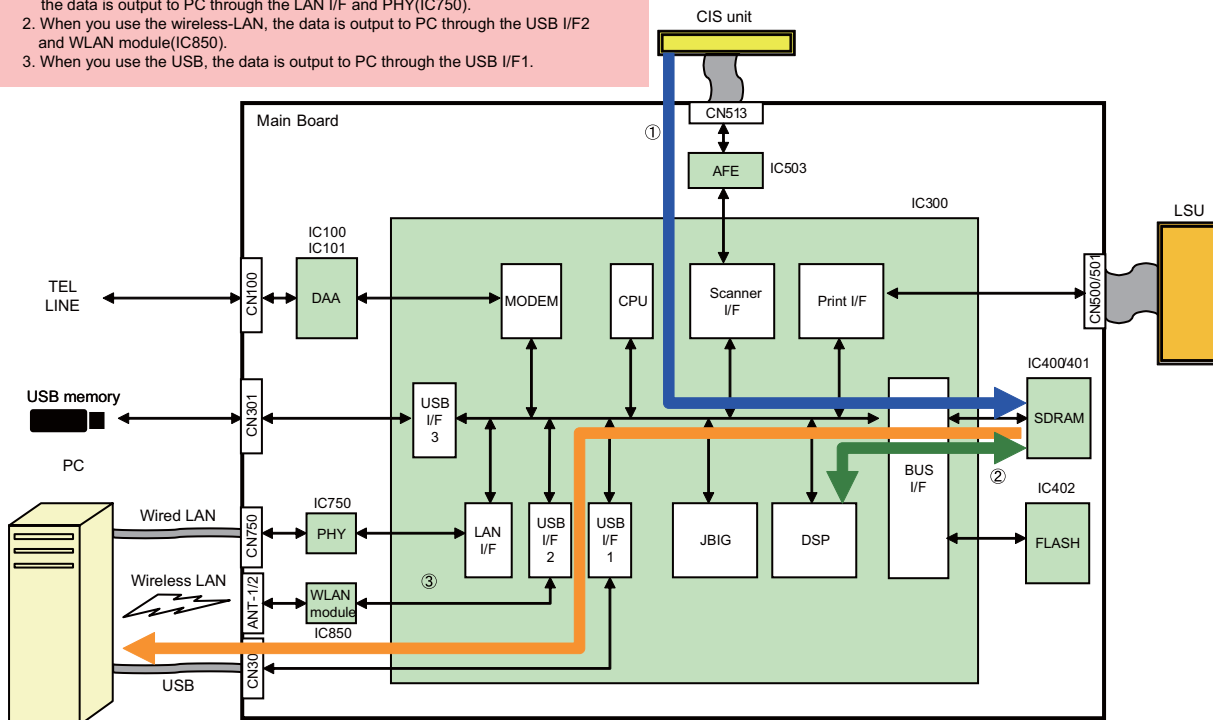

[PC print]

1. The print data is output from PC:
 - through Wired-LAN and pass the PHY (IC750) and LAN I/F in IC300.
 - through Wireless LAN and pass the WLAN module (IC850) and USB I/F2 in IC300.
 - through USB and pass the USB I/F1 in IC300.
 then the data is stored in IC400/401 through SDRAM I/F.
2. If necessary, the data is decompressed via JBIG.
3. Print I/F retrieve the data from IC400/401 and output it to LSU.

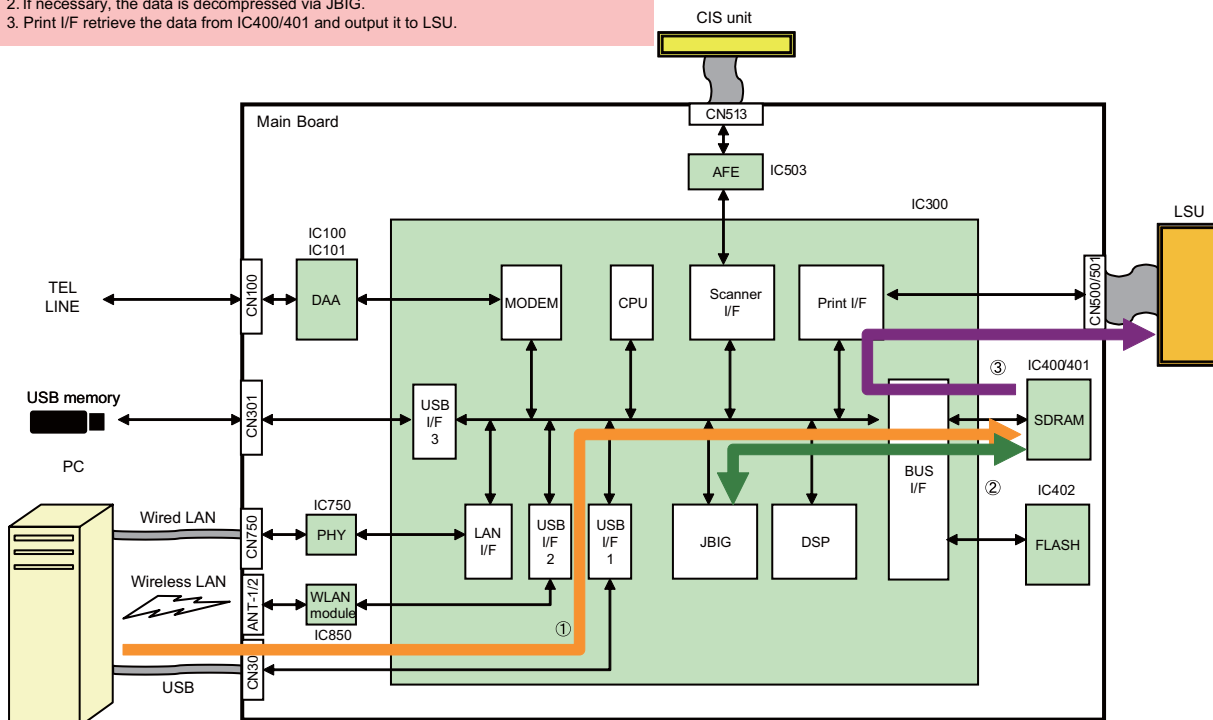

[Scan to USB memory]

※MB 22xx is excludes.

1. An analog image data is output from CIS unit to IC503.
IC503 decode the analog data to digital data, and output to IC300.
Scanner I/F in IC300 process image data and store it in IC400/401 through SDRAM I/F.
2. If necessary, DSP process image data.
3. The data is sent from IC400/401 to USB memory.

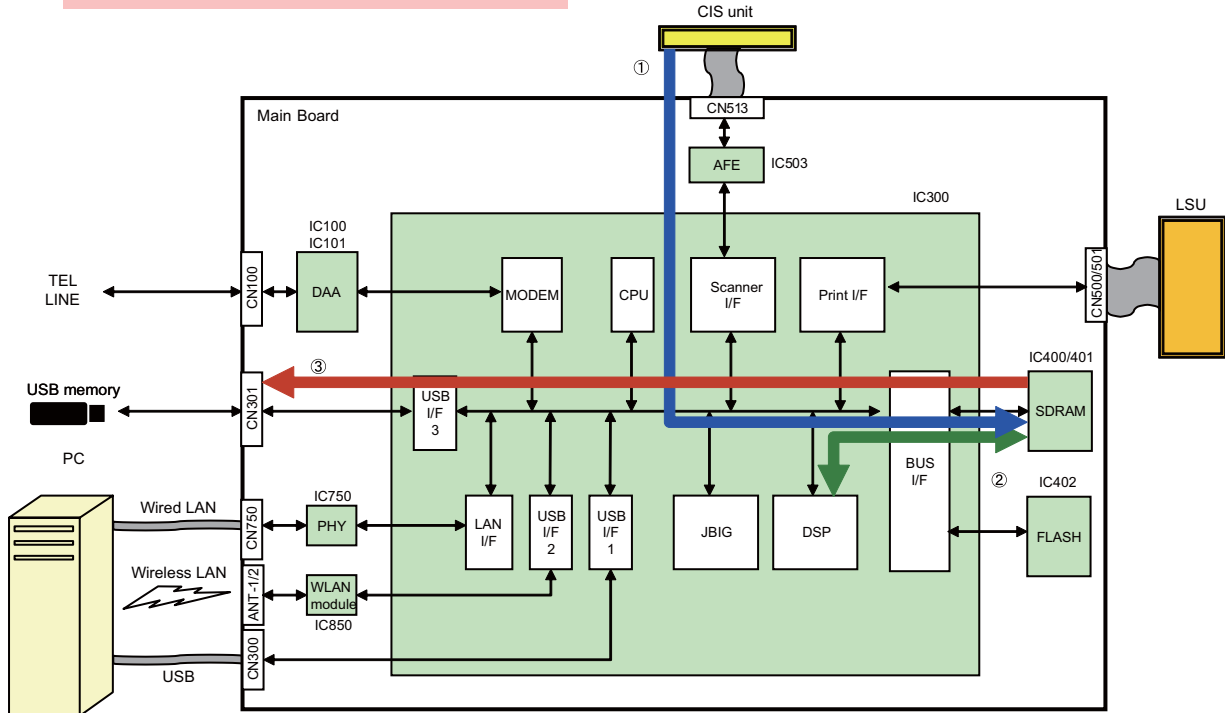

[USB Direct print]

※MB 22xx is excludes.

1. The data is transferred from USB memory to IC400/401.
2. Print I/F retrieve the data from IC400/401 and output it to LSU.

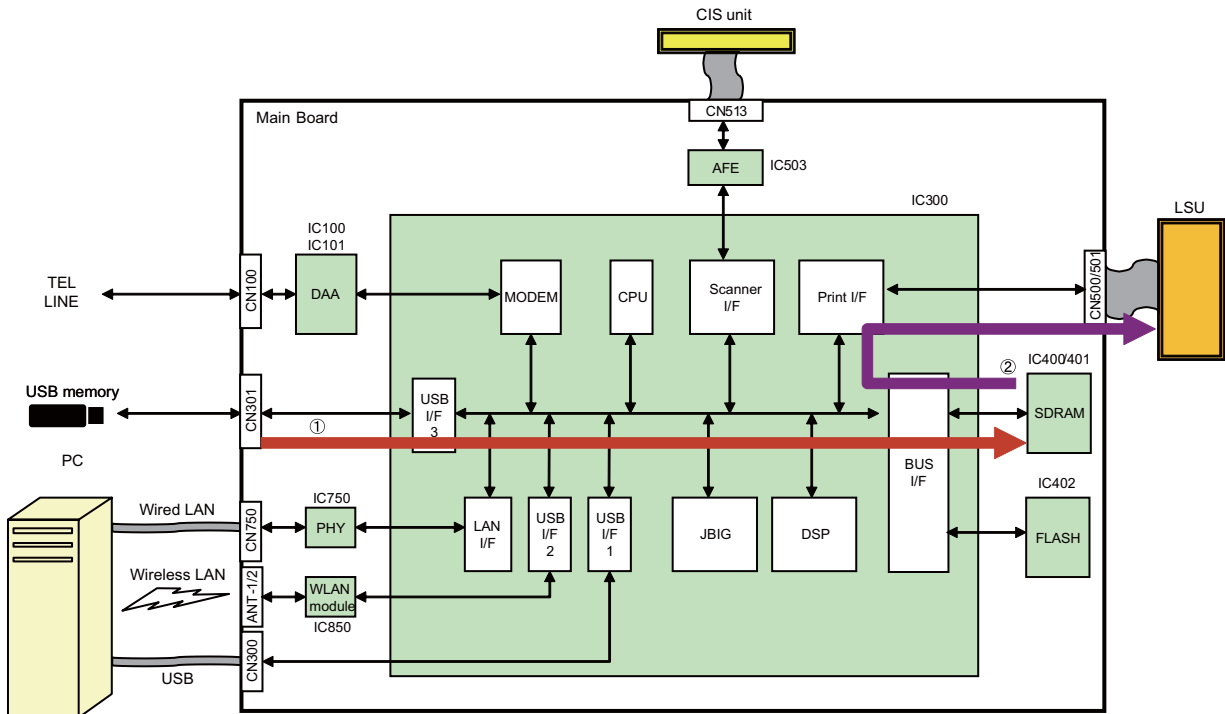

Description of Pin Distribution (IC300) SOC (System On Chip)

Pin No.	Pin Name	I/O	Description
A2	SDCLK	O	SDRAM Clock
G1	SDCKE	O	SDRAM Clock Enable
A9	NSDCS	O	SDRAM Chip Select
A8	NSDRAS	O	SDRAM Row Address Strobe
B8	NSDCAS	O	SDRAM Column Address Strobe
A7	NSDWE	O	SDRAM Write Enable
F1	SDLDM1	O	SDRAM Data Mask For Higher Byte (DQ[15:8])
B7	SDLDM0	O	SDRAM Data Mask For Lower Byte (DQ[7:0])
C5	SDBA1	O	SDRAM Bank Address1
C4	SDBA0	O	SDRAM Bank Address0
C9	ROMCE	O	Flash/Mask ROM Chip Enable
B9	ROMOE	O	Flash/Mask ROM Output Enable
J4	ROMWE	O	Flash ROM Write Enable
M2	ADR25	O	NOT USED
M1	ADR24	O	NOT USED
H3	ADR23	O	NOT USED
H4	ADR22	O	NOT USED
L1	ADR21	O	NOT USED
K2	ADR20	O	Flash ROM Address
K1	ADR19	O	Flash ROM Address
L2	ADR18	O	Flash ROM Address
L3	ADR17	O	Flash ROM Address
M3	ADR16	O	Flash ROM Address
J1	ADR15	O	Flash ROM Address
J2	ADR14	O	Flash ROM Address
J3	ADR13	O	Flash ROM Address
D3	ADR12	O	Flash ROM/SDRAM Address
E3	ADR11	O	Flash ROM/SDRAM Address
C6	ADR10	O	Flash ROM/SDRAM Address
F3	ADR9	O	Flash ROM/SDRAM Address
G2	ADR8	O	Flash ROM/SDRAM Address
G3	ADR7	O	Flash ROM/SDRAM Address
G4	ADR6	O	Flash ROM/SDRAM Address
H1	ADR5	O	Flash ROM/SDRAM Address
H2	ADR4	O	Flash ROM/SDRAM Address
D8	ADR3	O	Flash ROM/SDRAM Address
C8	ADR2	O	Flash ROM/SDRAM Address
D7	ADR1	O	Flash ROM/SDRAM Address
C7	ADR0	O	Flash ROM/SDRAM Address
F2	DAT15	I/O	Flash ROM/SDRAM Data
E1	DAT14	I/O	Flash ROM/SDRAM Data
E2	DAT13	I/O	Flash ROM/SDRAM Data
D1	DAT12	I/O	Flash ROM/SDRAM Data
D2	DAT11	I/O	Flash ROM/SDRAM Data
C1	DAT10	I/O	Flash ROM/SDRAM Data
C2	DAT9	I/O	Flash ROM/SDRAM Data
B1	DAT9	I/O	Flash ROM/SDRAM Data
B3	DAT7	I/O	Flash ROM/SDRAM Data
A3	DAT6	I/O	Flash ROM/SDRAM Data
B4	DAT5	I/O	Flash ROM/SDRAM Data
A4	DAT4	I/O	Flash ROM/SDRAM Data
B5	DAT3	I/O	Flash ROM/SDRAM Data
A5	DAT2	I/O	Flash ROM/SDRAM Data
B6	DAT1	I/O	Flash ROM/SDRAM Data
A6	DAT0	I/O	Flash ROM/SDRAM Data
AF13	USBDP1	I/O	USB(device) Interface
AE13	USBDM1	I/O	USB(device) Interface
AE11	USBVBUS1	I	USB(device) Interface
AF11	USBRES1	I/O	Pull down
AE14	USBSEL1	I	3.3V
AC1	USBDP2	I/O	NOT USED (others) WLAN module Interface (KX-MB2*7* ONL)
AC2	USBDM2	I/O	NOT USED (others) WLAN module Interface (KX-MB2*7* ONLY)
AB2	USBVBUS2	I	Pull down

Pin No.	Pin Name	I/O	Description
AB1	USBRES2	I/O	Pull down
AA2	USBSEL2	I	GND
V1	USBDP3	I/O	NOT USED (KX-MB22** ONLY) USB(host) Interface (others)
V2	USBDM3	I/O	NOT USED (KX-MB22** ONLY) USB(host) Interface (others)
U2	USBVBUS3	O	Pull down
U1	USBRES3	I/O	Pull down
T2	USBSEL3	I	3.3V
AF5	REF_CLK	I	Ethernet Clock (pre clock tree)
AE3	TX_EN	O	Ethernet Transmit Enable
AF2	TXD0	O	Ethernet Transmit Data
AF3	TXD1	O	Ethernet Transmit Data
AD4	RX_ER	I	Ethernet Receive Error
AE6	CRS_DV	I	Ethernet Receive Data Valid
AF4	RXD0	I	Ethernet Receive Data
AE4	RXD1	I	Ethernet Receive Data
AD5	MDIO	I/O	Ethernet Management Data In/OUT
AE5	MDC	O	Ethernet Management Data Clock
AD6	MGTINT	I	Ethernet Management INT
AF22	PSCIO0	I	INPUT PORT (RESIST)
AD23	PSCIO1	I	INPUT PORT (PICK)
AE23	PSCIO2	I	INPUT PORT (FANDET1)
AF23	PSCIO3	I	INPUT PORT (EXIT)
AF24	PSCIO4	I	INPUT PORT (MPT)
AE26	PSCIO5	I	INPUT PORT (OPPAPER)
AD25	PSCIO6	O	NOT USED
AD26	PSCIO7	I	INPUT PORT (PAPER)
AC24	PSCIO12	I	INPUT PORT (CSOPEN)
AC25	PSCIO13	I	INPUT PORT (TNR)
AC26	PSCIO14	I	INPUT PORT (DOCU)
AB24	PSCIO15	I	INPUT PORT (RPS)
AB25	PSCIO16	I	INPUT PORT (ADFJAM)
AB26	PSCIO17	O	NOT USED
AA24	PSCIO18	I	INPUT PORT (TOPCVR)
AA25	PSCIO19	I	INPUT PORT (PTOP)
AA26	PSCIO20	I	INPUT PORT (OPPICK)
Y24	PSCIO21	I	INPUT PORT (OPC_CNTCT)
Y25	PSCIO22	I	INPUT PORT (OPC_LIFE)
Y26	PSCIO23	I	INPUT PORT (ADU)
W26	PSCIO24	I	LSU Interface
H23	PIO0	O	OUTPUT PORT (SNADU)
J23	PIO1	I	INPUT PORT (HVERR)
J24	PIO2	O	LSU Interface
J25	PIO3	O	NOT USED
J26	PIO4	O	OUTPUT PORT (CHG)
K23	PIO5	O	OUTPUT PORT (DEV)
K24	PIO6	O	OUTPUT PORT (TRS)
K25	PIO7	O	OUTPUT PORT (FANON1)
K26	PIO8	I	INPUT PORT (TNR_CNTCT)
L24	PIO9	I	INPUT PORT (TNR_LIFE)
L25	PIO10	O	OUTPUT PORT (SHUTDOWN)
L26	PIO11	O	OUTPUT PORT (SNRESIST)
M23	PIO12	O	OUTPUT PORT (XLANRST)
M24	PIO13	I/O	INTPUT/OUTPUT PORT (PWRSW)
M25	PIO14	O	OUTPUT PORT (SNADF)
M26	PIO15	O	OUTPUT PORT (LEDCTL)
N24	PIO16	I	INPUT PORT (MODEL0)
N25	PIO17	I	INPUT PORT (MODEL1)
N26	PIO18	I	INPUT PORT (MODEL2)
P24	PIO20	O	OUTPUT PORT (SNADFSWBK)
P25	PIO21	O	LSU Interface
P26	PIO22	I	INPUT PORT (REARCVR)
R24	PIO23	O	OUTPUT PORT (NRST_W)
R25	PIO24	I	3.3V
R26	PIO25	I	LSU Interface
A10	PIO26	O	SDRAM Interface

Pin No.	Pin Name	I/O	Description
T24	PIO27	O	SPT Interface
T25	PIO28	O	SPT Interface
T26	PIO29	O	Operation Panel Interface
U24	PIO30	I/O	Operation Panel Interface
U25	PIO31	O	Operation Panel Interface
U26	PIO32	O	Operation Panel Interface
V24	PIO33	O	NOT USED (KX-MB2*1* ONLY)
		O	OUTPUT PORT (CNGMUTE)(Others)
V25	PIO34	O	SPT Interface
V26	PIO35	O	OUTPUT PORT (SNSWBK)
W24	PIO36	O	NOT USED (KX-MB2*1* ONLY)
		O	OUTPUT PORT (SPMUTE)(Others)
W25	PIO37	O	NOT USED (KX-MB2*1* ONLY)
		I	INPUT PORT (BELL)(Others)
B24	PIO38	O	NOT USED
A25	PIO39	O	NOT USED (KX-MB2*1* ONLY)
		I	INPUT PORT (HOOK)
B26	PIO40	O	NOT USED
C25	PIO41	I	INPUT PORT (24VMON)
C26	PIO42	O	Main Motor Interface
D24	PIO43	O	Main Motor Interface
D25	PIO44	I	Main Motor Interface
D26	PIO45	O	Main Motor Interface
E26	PIO46	O	NOT USED (KX-MB22** ONLY)
F24	PIO47	O	Option Feeder Motor Interface (others)
F25	PIO48	O	
F26	PIO49	O	OUTPUT PORT (PWRDWN2)
B21	PIO50	O	ADF/Flatbed Motor Interface
A21	PIO51	O	ADF/Flatbed Motor Interface
C22	PIO52	O	ADF/Flatbed Motor Interface
B22	PIO53	O	ADF/Flatbed Motor Interface
A22	PIO54	O	ADF/Flatbed Motor Interface
B23	PIO55	O	ADF/Flatbed Motor Interface
A23	PIO56	O	ADF/Flatbed Motor Interface
A24	PIO57	O	ADF/Flatbed Motor Interface
G23	PIO58	O	SPT Interface
B10	PIO59	O	OUTPUT PORT (PWRDWN1)
G24	PIO60	O	NOT USED (KX-MB2*1* ONLY)
		I	INPUT PORT (AINT)(Others)
G25	PIO61	O	NOT USED (KX-MB2*1* ONLY)
			OUTPUT PORT (HSSPMUTE) (Others)
G26	PIO62	O	LSU Interface
H24	PIO63	O	LSU Interface
H25	PIO64	O	I2C Interface
H26	PIO65	O	I2C Interface
P23	PIO66	O	NOT USED (KX-MB2*1* ONLY)
		O	OUTPUT PORT (LINERLY) (Others)
AE22	HTRCTL	O	Fuser Lamp Control
E24	MMPWR	O	NOT USED
E25	OPMPWR	O	NOT USED (KX-MB22** ONLY) Option Feeder Motor Interface (others)
C23	CRMPWR	O	ADF/Flatbed Motor Interface
B11	CCDSH	O	Scanner Interface
B12	NCCDRS	O	Scanner Interface
A12	NCCDCP	O	NOT USED
A11	CCDCLK	O	NOT USED
B15	AFEVSMP	O	Scanner Interface
C15	AFERSMP	O	Scanner Interface
A15	AFEMCLK	O	Scanner Interface
D14	AFEADC0	I	GND
C14	AFEADC1	I	GND
D13	AFEADC2	I	GND
C13	AFEADC3	I	GND
B14	AFEADC4	I	Scanner Interface
A14	AFEADC5	I	Scanner Interface
B13	AFEADC6	I	Scanner Interface
A13	AFEADC7	I	Scanner Interface

Pin No.	Pin Name	I/O	Description
A16	AFESIFCLK	O	Scanner Interface
B16	AFESIFEN	O	Scanner Interface
A17	AFESIFDIN	I	Scanner Interface
B17	AFESIFDOUT	O	Scanner Interface
C12	OEB	O	NOT USED
D12	NCCDON	O	Scanner Interface
D16	LEDONR	O	Scanner Interface
C17	LEDONG	O	Scanner Interface
C16	LEDONB	O	Scanner Interface
AF18	ABITCLK	I	NOT USED (KX-MB2*1* ONLY)
		I	NCU Interface (Others)
AE18	ASPCLK	I	NOT USED (KX-MB2*1* ONLY)
		I	NCU Interface (Others)
AD18	ATXD	Tri-O	NOT USED (KX-MB2*1* ONLY)
		Tri-O	NCU Interface (Others)
AC18	ARXD	I	NOT USED (KX-MB2*1* ONLY)
		I	NCU Interface (Others)
AF20	BBITCLK	I	NOT USED (KX-MB2*1* ONLY)
		I	NCU Interface (Others)
AE20	BSPCLK	I	NOT USED (KX-MB2*1* ONLY)
		I	NCU Interface (Others)
AD20	BTXD	Tri-O	NOT USED (KX-MB2*1* ONLY)
		Tri-O	NCU Interface (Others)
AC20	BRXD	I	NOT USED (KX-MB2*1* ONLY)
		I	NCU Interface (Others)
AE19	AFERST	O	NOT USED (KX-MB2*1* ONLY)
		O	NCU Interface (Others)
AF19	AFECLK	O	NOT USED (KX-MB2*1* ONLY)
		O	NCU Interface (Others)
AD17	RING	I	NOT USED (KX-MB2*1* ONLY)
		I	NCU Interface (Others)
AF21	DP	O	NOT USED (KX-MB2*1* ONLY)
		O	NCU Interface (Others)
AF17	EYECLK	O	NOT USED
AE17	EYEDAT	O	NOT USED
AD19	AFESSEL0	I	3.3V
AC19	AFESSEL1	I	3.3V
R4	DBGREQ	I	NOT USED
T3	DBGMOD	O	NOT USED
Y3	MDM_TDO	Tri-O	NOT USED
Y2	MDM_TMS	I	NOT USED
W4	MDM_TRSTN	I	NOT USED
Y1	MDM_TCK	I	NOT USED
AA1	MDM_TDI	I	NOT USED
AE12	SCLKIN	I	CRYSTAL(24MHz) INPUT
AF12	SCLKOUT	O	CRYSTAL(24MHz) OUTPUT
AF25	MDMCLKIN	I	CRYSTAL(24.576MHz) INPUT
AE24	MDMCLKOUT	O	CRYSTAL(24.576MHz) OUTPUT
A18	DOTCLKIN	I	CLOCK(30MHz) INPUT
B18	DOTCLKOUT	O	NOT USED
AE8	RTCCLKIN	I	CRYSTAL(32.768MHz) INPUT
AF8	RTCCLKOUT	O	CRYSTAL(32.768MHz) OUTPUT
AD7	RTCPWRDWN	I	RTC RESET
AF6	NBATRST	I	RTC RESET
AE15	CPU_TDI	I	NOT USED
AE16	CPU_TMS	I	NOT USED
AF15	CPU_TCK	I	NOT USED
AF16	CPU_TRSTN	I	NOT USED
AD15	CPU_TDO	Tri-O	NOT USED
R2	DSP_TDI	I	NOT USED
P2	DSP_TMS	I	NOT USED
R1	DSP_TCK	I	NOT USED
R3	DSP_TRSTN	I	NOT USED
P1	DSP_TDO	Tri-O	NOT USED
C21	THRMSTR0	I	Analog Input (THRMISTOR)
C20	THRMSTR1	I	Analog Input (THRMISTOR)

Pin No.	Pin Name	I/O	Description
A19	TONE	O	Analog Output (Buzzer) (KX-MB2*1* ONLY)
		O	Analog Output (Speaker) (Others)
B20	ADVREF	I	GND
C19	DAVREFP	I	GND
A20	DAVREFN	I	GND
N1	NRST	I	Reset
N2	NWDTRST	Tri-O	Watch Dog Timer Reset Signal
AD16	TEST	I	NOT USED
AC15	TEST_MODE	I	GND
Y23	CLKSEL0	I	GND
W23	CLKSEL1	I	GND
V23	CLKSEL2	I	GND
T23	CLKSEL3	I	3.3V
R23	CLKSEL4	I	GND
AC16	BYPASS	I	GND
N3	BOOTMOD	I	NOT USED
D21	AD_AVDD25	-	2.5VA Power Supply for A/D
D19	DA_AVDD25	-	2.5VA Power Supply for D/A
AF7	BAT_DVDD	-	3.3V Power Supply for RTC
AE7	BAT_VDD	-	1.2V Power Supply for RTC
AC21	PLL2_DVDD	-	2.5VA Power Supply for PLL
D18	PLL3_DVDD	-	2.5VA Power Supply for PLL
AF10	PRG_AVDD	-	3.3V Power Supply
AC9	SSPLL_VDDA	-	1.2VA Power Supply for PLL
AC10	PRG_VOUT12	-	1.2VA output
AC11	PRG_VOUT25	-	2.5VA output
AC12	USB1_AVDD25	-	2.5VA Power Supply for USB1
AF14	USB1_AVDD33	-	3.3V Power Supply for USB1
AA4	USB2_AVDD25	-	2.5VA Power Supply for USB2
AD1	USB2_AVDD33	-	3.3V Power Supply for USB2
V4	USB3_AVDD25	-	2.5VA Power Supply for USB3
W1	USB3_AVDD33	-	3.3V Power Supply for USB3
AA23	VDD12	-	1.2V Power Supply
AB4	VDD12	-	1.2V Power Supply
AC6	VDD12	-	1.2V Power Supply
AC13	VDD12	-	1.2V Power Supply
AC17	VDD12	-	1.2V Power Supply
AC22	VDD12	-	1.2V Power Supply
D6	VDD12	-	1.2V Power Supply
D10	VDD12	-	1.2V Power Supply
D15	VDD12	-	1.2V Power Supply
D22	VDD12	-	1.2V Power Supply
E23	VDD12	-	1.2V Power Supply
F4	VDD12	-	1.2V Power Supply
L23	VDD12	-	1.2V Power Supply
N4	VDD12	-	1.2V Power Supply
N23	VDD12	-	1.2V Power Supply
T4	VDD12	-	1.2V Power Supply
AC8	VDDIO33	-	3.3V Power Supply
AC14	VDDIO33	-	3.3V Power Supply
D5	VDDIO33	-	3.3V Power Supply
D11	VDDIO33	-	3.3V Power Supply
D17	VDDIO33	-	3.3V Power Supply
F23	VDDIO33	-	3.3V Power Supply
K4	VDDIO33	-	3.3V Power Supply
P4	VDDIO33	-	3.3V Power Supply
U23	VDDIO33	-	3.3V Power Supply
AA3	VSS	-	GND
AB3	VSS	-	GND
AB23	VSS	-	GND
AC3	VSS	-	GND
AC4	VSS	-	GND
AC5	VSS	-	GND
AC23	VSS	-	GND
AD3	VSS	-	GND
AD9	VSS	-	GND
AD11	VSS	-	GND

Pin No.	Pin Name	I/O	Description
AD12	VSS	-	GND
AD13	VSS	-	GND
AD14	VSS	-	GND
AD22	VSS	-	GND
AD24	VSS	-	GND
AE2	VSS	-	GND
AE25	VSS	-	GND
B2	VSS	-	GND
B19	VSS	-	GND
B25	VSS	-	GND
C3	VSS	-	GND
C18	VSS	-	GND
C24	VSS	-	GND
D4	VSS	-	GND
D20	VSS	-	GND
D23	VSS	-	GND
E4	VSS	-	GND
L4	VSS	-	GND
L11	VSS	-	GND
L12	VSS	-	GND
L13	VSS	-	GND
L14	VSS	-	GND
L15	VSS	-	GND
L16	VSS	-	GND
M4	VSS	-	GND
M11	VSS	-	GND
M12	VSS	-	GND
M13	VSS	-	GND
M14	VSS	-	GND
M15	VSS	-	GND
M16	VSS	-	GND
N11	VSS	-	GND
N12	VSS	-	GND
N13	VSS	-	GND
N14	VSS	-	GND
N15	VSS	-	GND
N16	VSS	-	GND
P11	VSS	-	GND
P12	VSS	-	GND
P13	VSS	-	GND
P14	VSS	-	GND
P15	VSS	-	GND
P16	VSS	-	GND
R11	VSS	-	GND
R12	VSS	-	GND
R13	VSS	-	GND
R14	VSS	-	GND
R15	VSS	-	GND
R16	VSS	-	GND
T11	VSS	-	GND
T12	VSS	-	GND
T13	VSS	-	GND
T14	VSS	-	GND
T15	VSS	-	GND
T16	VSS	-	GND
U3	VSS	-	GND
U4	VSS	-	GND
V3	VSS	-	GND
W3	VSS	-	GND
Y4	VSS	-	GND

6.3.2. RTC Backup Circuit

1. Function

This unit has a lithium battery (BAT300) which works for the Real Time Clock IC (RTC: inside IC300). The RTC continues to work, backed up by a lithium battery even when the power switch is OFF.

*RTC:(Real Time Clock)

Chip for the clock mounted on the motherboard.

Receiving power supply to operate even while the power is off unlike the other chips on the motherboard.

2. RTC Inside (IC300) Backup Circuit Operation

When the power switch is turned ON, power is supplied to the RTC (inside IC300). At this time, the voltage at pin AF7 of the IC300 is +3.3V. When the power switch is turned OFF, the BAT300 supplies power to RTC through DA300.

When the power switch is OFF and the voltage of +3.3V decreases, pin AF7 of RTC (IC300) becomes roughly the same voltage as the battery voltage. RTC goes into the backup mode, in which the power consumption is lower.

Circuit Diagram

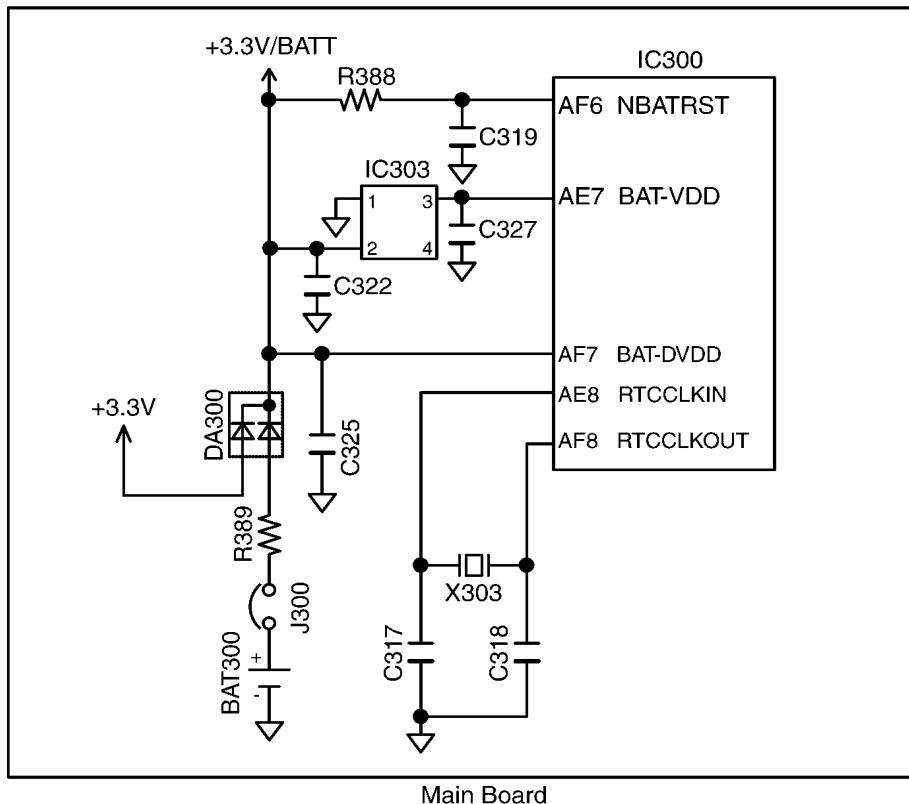

6.3.3. Modem Circuit Operation (Fax supported models only)

The modem (Included IC300) has all the hardware satisfying the CCITT standards mentioned previously.

ALL processing is controlled by the SOC (IC300) according to CCITT procedures.

This modem (Included IC300) has an automatic application equalizer. With training signal 1 or 2 at the time of G3 reception, it can automatically establish the optimum equalizer.

Facsimile Transmission/DTMF Line Send

The digital image data sent on ATXD line from modem (Included IC300).

DAA IC100 (6→9,10), Line side DAA IC101 and the NCU section to the telephone line.

Facsimile Reception

The analog image data which is received from the telephone line passes through the NCU section and enters line side DAA (Direct Access Arrangement) IC100. The signals are changed to digital data in IC101 (5,6), IC100 (9,10→5) and IC300. In this case, the image signals from the telephone line are transmitted serially. Here, the internal equalizer circuit reduces the image signals to a long-distance receiving level. This is designed to correct the characteristics of the frequency band centered around 3kHz and maintain a constant receiving sensitivity.

Busy/Dial Tone Detection

The path is the same as Facsimile Reception.

Call Tone Transmission

This is the call signal which is generated the SOC (IC300) and sent to the speaker.

6.3.4. TEL Line Section (Fax supported models only)

Composed of ITS circuit and NCU circuit.

6.3.4.1. Description of Block Diagram in Analog Section

Function

The analog section works as an interface between the telephone line.

DAA control ITS circuit and NCU circuit.

DAA control signals are output from SOC (IC300).

Circuit Operation

[NCU]: Network Control Unit the NCU comprises of the following; DC loop forming circuit to connect with the telephone line;

Switching circuit for other interconnected telephones; Bell detection circuit; Remote fax activation circuit.

Refer to **NCU Section (Fax supported models only)** (P.47) for the details.

6.3.4.2. Block Diagram

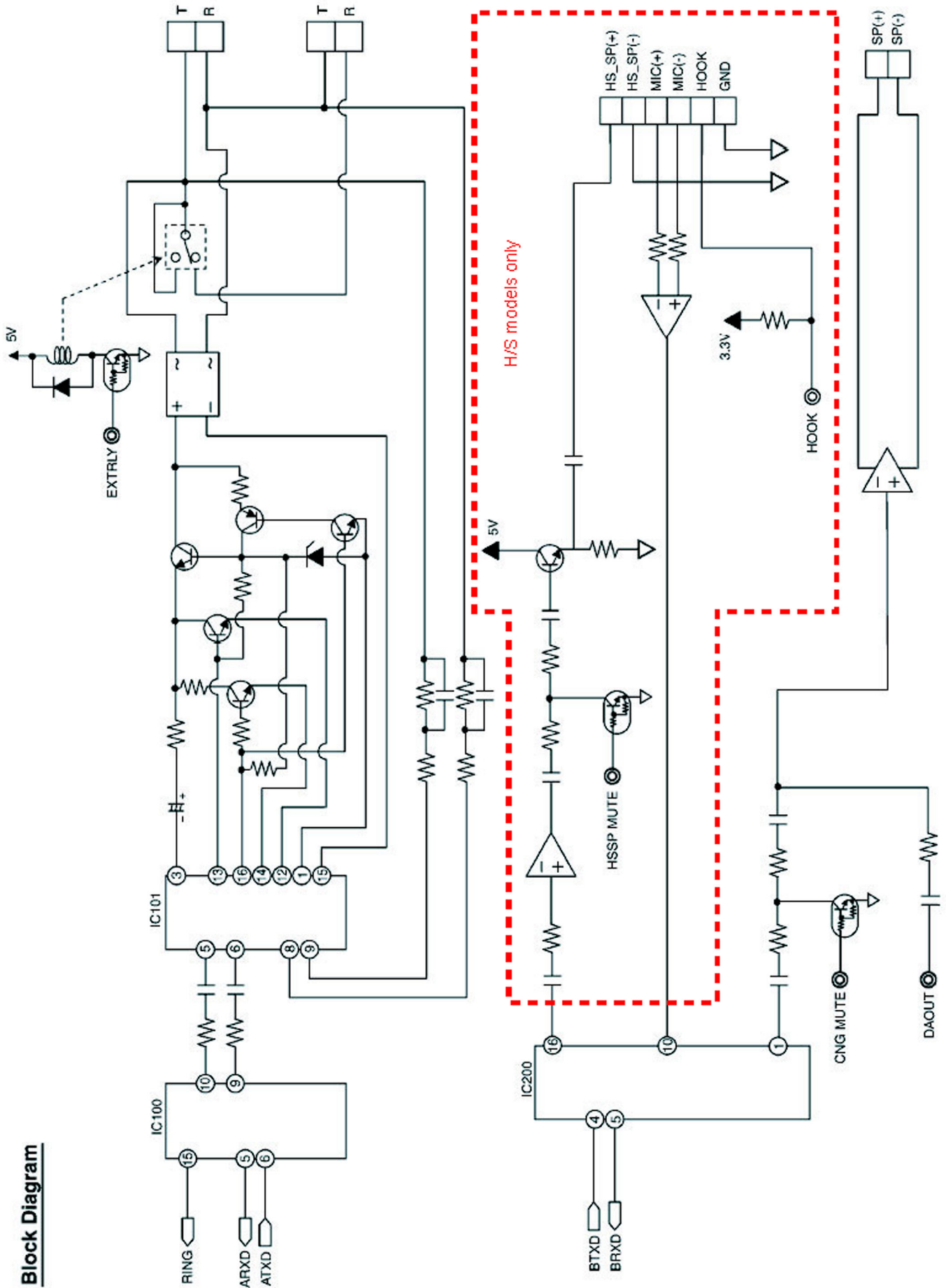

Block Diagram

6.4. NCU Section (Fax supported models only)

NCU: (Network Control Unit)

Requires for connecting computers to public communication networks and send a dial signal to call the other party.

6.4.1. General

NCU is the with the telephone line. It is composed of an EXT. TEL. line relay (RLY100), bell detection circuit, TAM interface circuit and line amplifier. The following is a brief explanation of each circuit.

6.4.2. EXT. TEL. Line Relay (RLY100)

1. Circuit Operation

Normally, this relay switches to the external telephone side and switches to the open side while OFF-HOOK.

IC300 (P23) High Level→Q105 ON→RLY100 (ON)

6.4.3. Bell Detection Circuit

1. Circuit Operation

The signal waveform is indicated below. The bell signal input to IC101 and ring detected signal output from pin 15 of IC100. IC300 monitor this signal and judged as bell.

TEL LINE→IC101 (8,9-5,6) → IC100 (9,10-15) → IC300 (AD17).

Between the Tip and Ring
from the telephone line

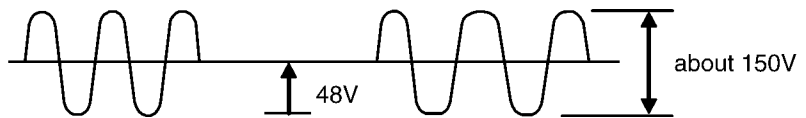

IC100 (15) / IC300 (AD17)

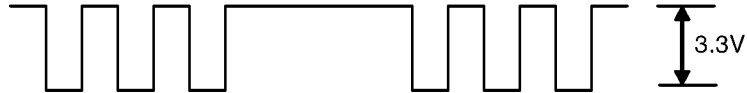

6.4.4. Remote FAX Activation Circuit

1. Function

Another telephone connected to same line activates the unit to the FAX mode by using a DTMF signal.

2. Signal Path

Refer to **Check Sheet** for Signal Route of CNG/DTMF detection (P.234).

6.4.5. TAM Interface Circuit

This circuit is to switch between FAX receiving and the external TAM's message recording automatically.

For details, please refer to **TAM Interface Section** (P.48).

6.5. ITS (Integrated telephone System) and Monitor Section (Fax supported models only)

6.5.1. General

The general ITS operation is performed by IC201 which has a handset circuit. The alarm tone, the key tone, and the beep are output from SOC (IC300).

6.5.1.1. Telephone Monitor

1. Function

This is the function when you are not holding the handset and can hear the caller's voice from the line.

2. Circuit Operation

(Signal Path)

Signals received from the telephone line are output through at the speaker via the following path.

3. Signal Path

Refer to **Check Sheet** for Signal Route of MONITER RX (P.234).

6.5.1.2. Monitor Circuit

1. Function

This circuit monitors various tones, such as (1) DTMF tone, (2) Alarm/Beep/Key tone/Bell.

2. Signal Path

a. DTMF Monitor

(Speaker Operation)

Refer to **Check Sheet** for Signal Route of DTMF Monitor (Speaker) (P.234).

b. ALARM/BEEP/KEY TONE/BELL

Refer to **Check Sheet** for Signal Route of MONITER RX (P.234).

6.5.1.3. TAM Interface Section

1. Function

When TAM is connected to this unit, the unit receives documents for FAX calls or the external TAM records a voice message automatically.

2. Circuit Operation

The TAM INTERFACE circuit consists of Soc(IC300) to detect the other party CNG signal, and RLY100 to separate EXT.TAM.

a. CNG Signal Detection Circuit

The CNG signal from the other party's FAX is detected in SOC (IC300).

(Signal path)

Refer to **Check Sheet** for Signal Route of CNG/DTMF detection (P.234).

b. Remote Receiving

This is the parallel-connected DTMF signal for the TEL or EXT.TEL mode between T and R. When the other party is a FAX, the unit switches to FAX receiving.

(Signal Path)

Refer to **Check Sheet** for Signal Route of CNG/DTMF detection (P.234).

6.6. CIS Control Section

The scanning block of this device consists of a control circuit and a CIS (contact image sensor), and AFE (Analog Front End) include A/D Converter.

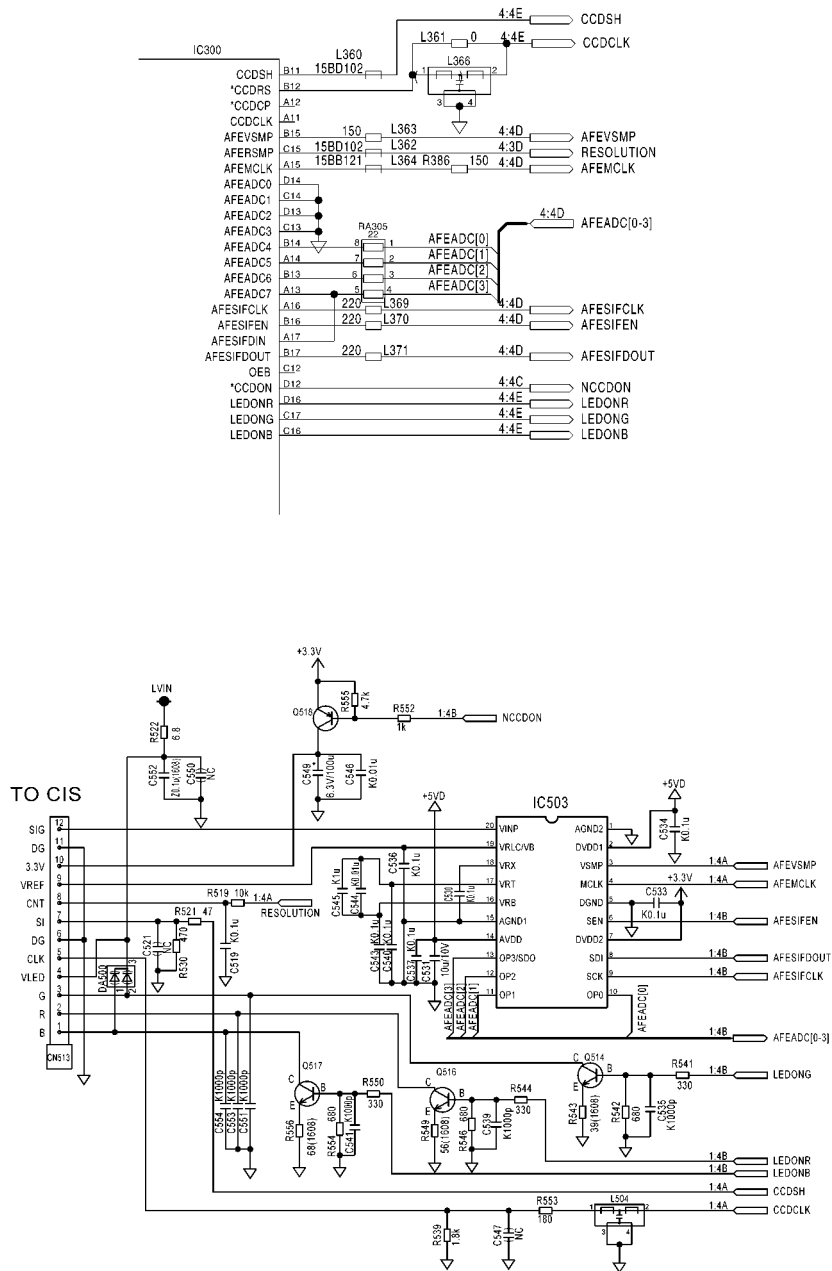

When start the scanning, pin A3 of IC300 will be low level and the transistor Q518 turns on, 3.3V is supplied to the CIS. The CIS is driven by each of the signals (CCDSH, CCDCLK, RESOLUTION) which are output from IC300. The analog image signal is input to the AFE (20pin of IC503), and converted into 16-bit data by the A/D converter inside. Then this signal undergoes digital processing in order to obtain a high-quality image in IC300.

Resolution

The CIS can change the resolution, 300dpi mode or 600dpi mode. If RESOLUTION signal is High level, CIS operates 600dpi mode. The other case is 300dpi mode.

Operation	CIS Resolution	
	300dpi	600dpi
COPY	-	ALL
PC SCAN	~300 X 300	400 X 400~
FAX	-	ALL

6.7. Motor Drive Section

6.7.1. Main Motor Control Circuit

1. Functions

All driving forces of printer engine part are supplied by this main motor.

Main motor is controlled so as to rotate at constant speed during printing and copying.

2. Motor operation

<Start operation>

In order to start the motor rotation, following 3 signals are supplied from IC300.

1. SS signal (Output pin: Pin D24/Output Signal: "H")

When this signal is inverted by transistor Q502 and becomes "L", motor recognize this signal as "start" signal.

2. Clock signal (Output pin: Pin C26/Output Signal: Pulse)

Pulse frequency :approx. 1.8KHz (at normal printing speed)

Pulse frequency :approx. 0.9KHz.(at half printing speed)

This signal is also inverted by transistor Q525, and supplied to motor as "clock" signal.

3. Brake signal (Output pin: Pin D26/Output Signal: "H")

When this signal is inverted by transistor Q526 and becomes "L", motor recognize this signal as "brake off" signal.

When motor reaches constant speed, "L" signal is supplied from motor to IC300 pin D25 as "Lock detect (LD)" signal.

If "LD" signal does not becomes "L" within predetermined period after "SS" signal becomes "H", or if "LD" signal becomes "H" during rotation, it is judged that motor Error occurred.

Timing Chart of Start operation

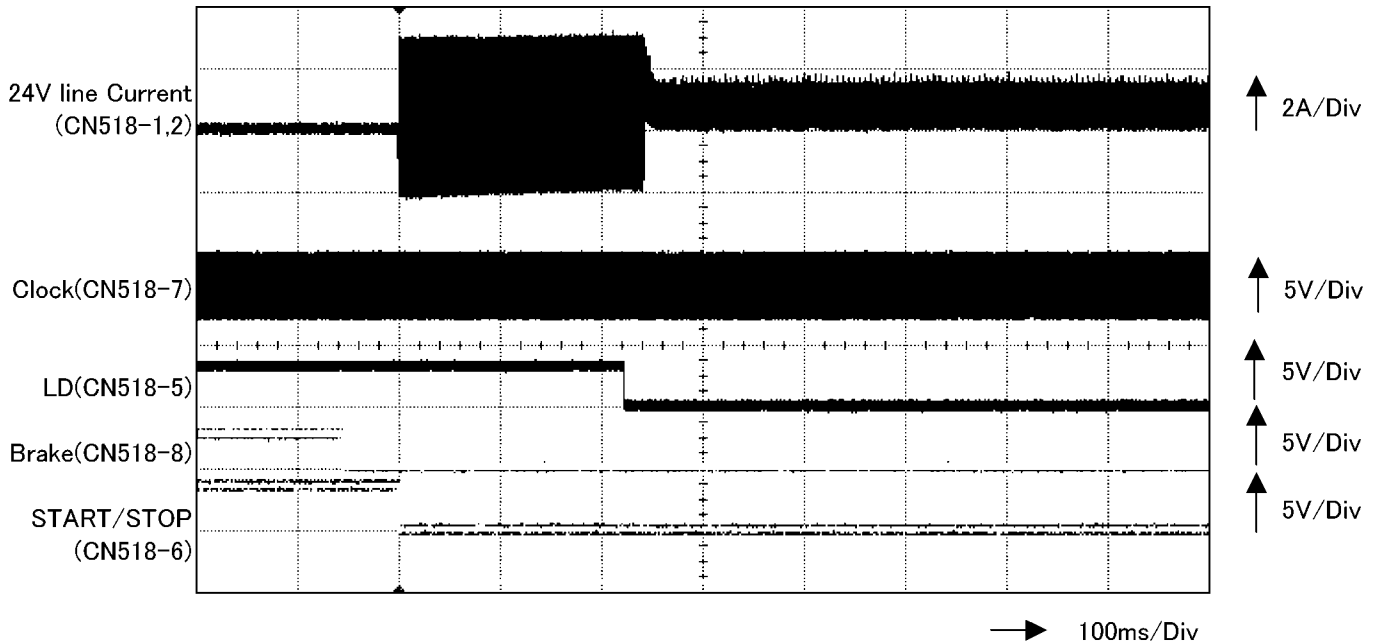

<Stop operation>

In order to stop the motor rotation, following 2 signals are supplied from IC300.

1. SS signal (Output pin: Pin D24/Output Signal: "L")

When this signal is inverted by transistor Q502 and becomes "H", motor recognize this signal as "stop" signal.

2. Brake signal (Output pin: Pin D26/Output Signal: "L")

When this signal is inverted by transistor Q526 and becomes "H", motor recognize this signal as "brake on" signal.

Timing Chart of Stop operation

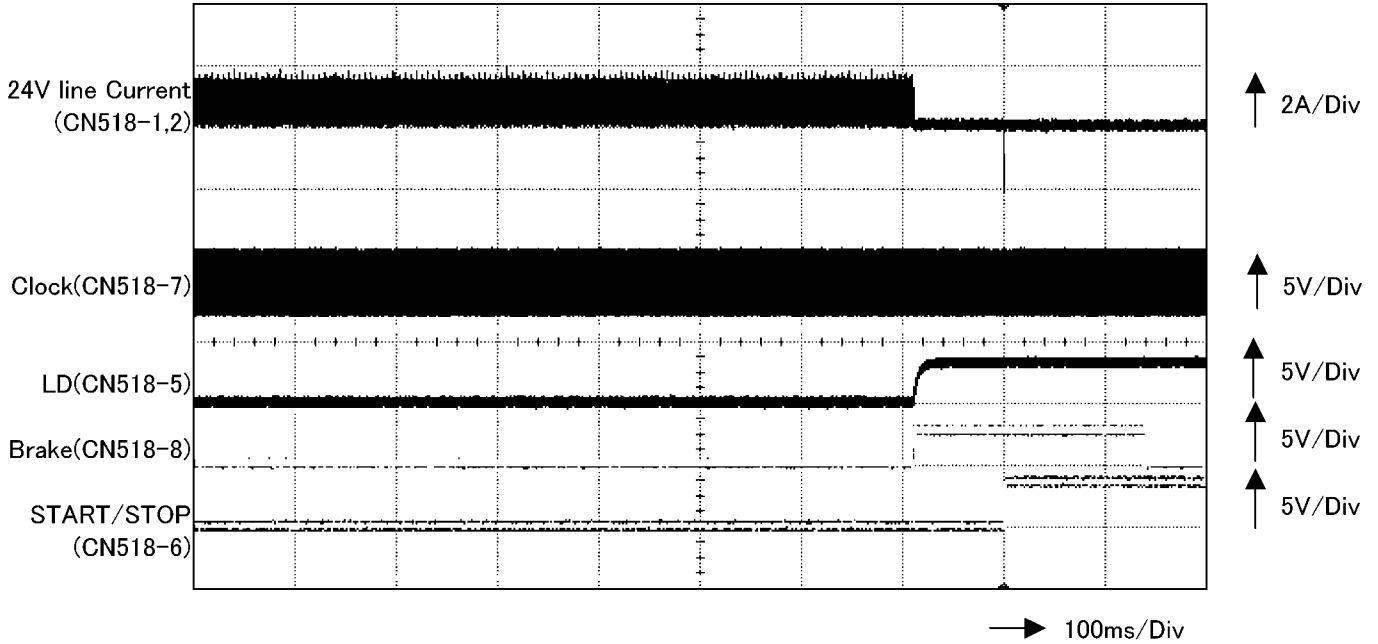

6.7.1.1. Main Motor Drive Circuit

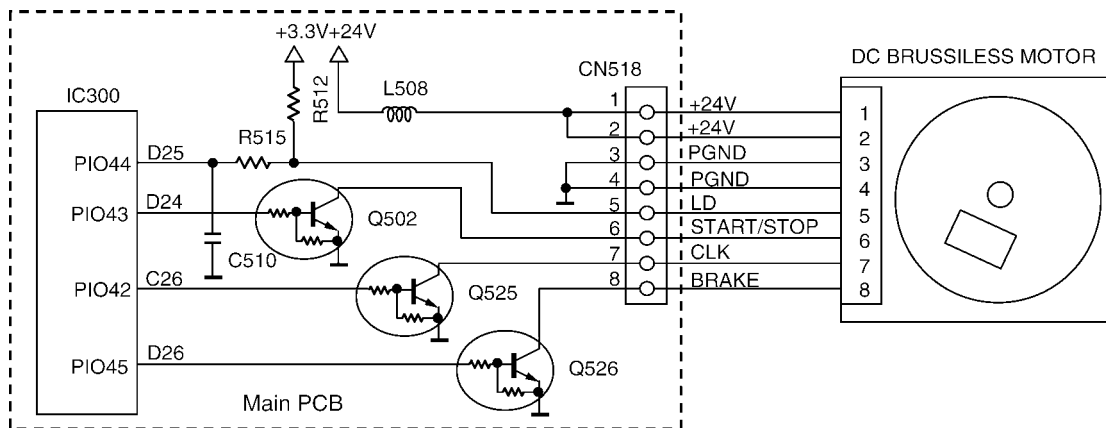

6.7.2. Scanner motor drive circuit

1. General

Scanner motor drive circuit consists of "Motor driver", "Motor current control circuit", and "O.C.P (Over Current Protection) circuit".

Scanner motor represents FB (Flatbed) motor and ADF (Auto document Feeder) motor.

FB motor feeds CIS unit in FB scan, FB copy, and FB FAX mode.

A one step rotation of this motor feeds CIS unit 0.021mm.

ADF motor feeds documents in ADF scan, ADF copy, and ADF FAX mode.

A one step rotation of this motor feeds documents 0.042mm.

2. Block Diagram of Scanner motor Drive circuit

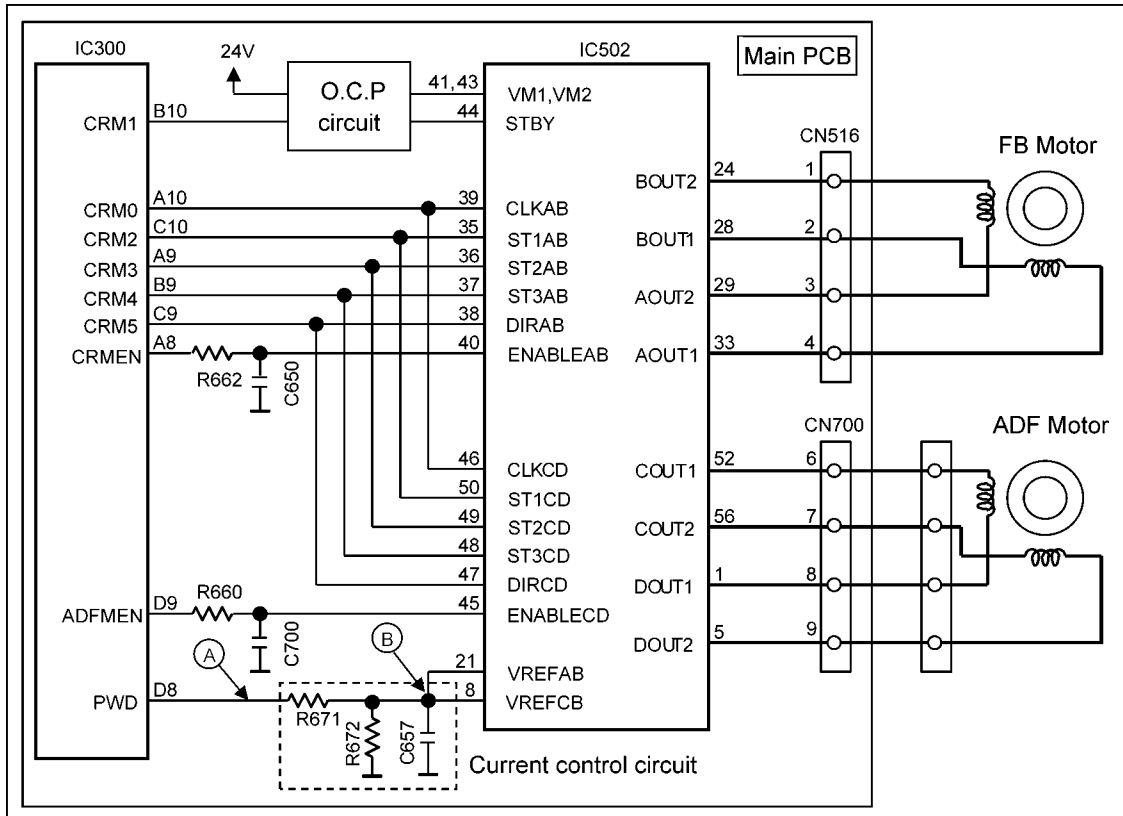

6.7.2.1. Motor driver

IC502 is the motor driver AN44071A.

This motor driver can drive both FB and ADF motors with 1 chip, and can supply up to 1.7A/phase and support up to 2W1-2 phase excitation.

When "CRMEN" signal (IC502_pin40) becomes "H", FB block of motor driver is activated, and motor currents are supplied from IC502_pin24, pin28, pin29 and pin33 to drive the FB motor coils.

When "ADFMEN" signal (IC502_pin45) becomes "H", ADF block of motor driver is activated, and motor currents are supplied from IC502_pin1, pin5, pin52 and pin56 to drive the ADF motor coils.

FB motor excitation mode is selected by the logic level of "ST1AB", "ST2AB" and "ST3AB" (IC502_pin35-pin37).

ADF motor excitation mode is selected by the logic level of "ST1CD", "ST2CD" and "ST3CD"(IC502_pin50-pin48).

The relation between motor excitation mode and logic level of "ENABLEAB"/"ENABLECD", "ST1AB"/"ST1CD", "ST2AB"/"ST2CD" and "ST3AB"/"ST3CD" are shown in below table.

Table1: Motor driver Excitation mode

*(pinxx) represents the pin No. of IC502

ENABLEAB(pin40) or ENABLECD(pin45)	ST1AB(pin35) or ST1CD(pin50)	ST2AB(pin36) or ST2CD(pin49)	ST3AB(pin37) or ST3CD(pin48)	Excitation mode
L	-	-	-	Disable
H	L	L	L	2 Phase(Not used)
H	L	H	L	N1-2phase
H	H	L	L	F1-2phase
H	H	H	L	W1-2phase
H	L	L	H	2W1-2phase

"DIRAB"(IC502_pin38) and "DIRCD"(IC502_pin47) determine the direction of motor rotation.

Although "DIRCD" determines the Main motor rotation direction, direction is not changed.

So "DIRCD" is fixed "H" level.

The relation between these signals and motor rotation directions are shown in below table.

Table2: Motor rotation direction

*(pinxx) represents the pin No. of IC502

Motor	DIRAB(pin38)	Operation Mode
FB	L	Scan
	H	Return

Motor	DIRCD(pin47)	Operation Mode
ADF	L	FEED
	H	Not used

After setting the above signals, clock signal is supplied from IC300_pinA10 to "CLKAB"(IC502_pin39) and "CLKCD"(IC502_pin46).

Whenever clock signal is supplied, current value and direction supplied to Scan motors change according to the excitation mode which is determined by above signal levels.

The clock frequency also determines the motor speed.

6.7.2.2. Motor current control circuit

1. Function

According to the scan speed motor current is controlled for appropriate value.

For example, when scan speed is low, motor has enough driving force.

So to prevent the vibration and noise during motor rotation, motor drive current should be reduced.

When scan speed is high, motor needs much driving force. so much current should be supplied.

In order to control the motor current, VREFAB and VREFCD voltages of IC502 is controlled.

When VREFAB and VREFCD voltages are high, motor currents are increased, and the voltages are low, motor currents are reduced.

2. Circuit Diagram

Please refer to the circuit diagram shown in the block diagram of **Scanner motor drive circuit (P.52)**.

3. Circuit explanation

For the sake of VREFAB and VREFCD voltage control, PWM pulse is supplied from IC300_pinD8.

PWM pulse is integrated by R671, R672 and C657, then converted to DC voltage.

This DC voltage is supplied to VREFAB and VREFCD pins of IC502.

When duty of PWM pulse is high, VREFAB and VREFCD voltages are increased and when duty is low, VREFAB and VREFCD voltages are decreased.

4. Timing chart of current control

Following timing charts are the example of VREFCD voltage corresponding to PWM pulse duty.

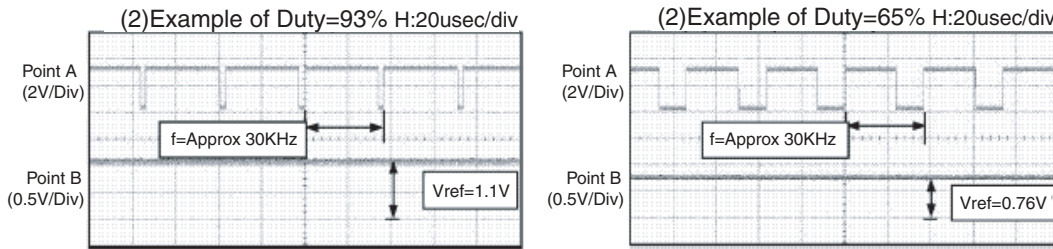

6.7.2.3. O.C.P. (Over Current Protection) circuit

1. Function

If motor driver can supply more than 15 watts, FB motors may become fire hazards.

To prevent the risk of fire, this circuit is provided.

2. Circuit diagram

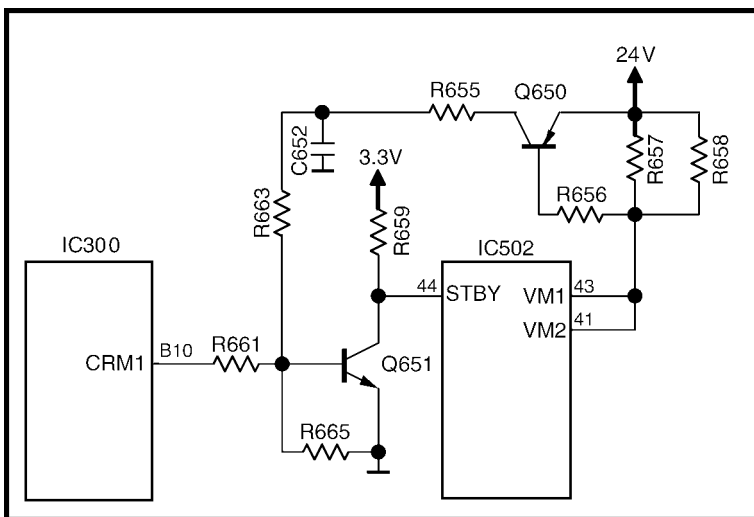

3. Circuit explanation

When the current supplied from 24V exceeds 0.44A, the voltage between two registers R657 and R658 becomes more than 0.6V ($=0.44A \times 2.7\Omega / 2$), consequently both Q650 and Q651 turn on, then "STBY" signal (IC502_pin44) becomes "Low" level.

When "STBY" signal becomes "Low" level, IC502 is deactivated and currents of both motors are cut off.

So the currents which IC502 can supply are limited to less than 0.44A and the wattage is also limited to less than 10.7W ($=0.44A \times 24V$).

By limiting the wattage less than 15W, risk of fire hazard is eliminated.

Also "CRM1" signal is provided from IC300_pinB10 to base of Q651.

This signal is designed to become "High" when software can not control motors properly by some accidents.

When base of Q651 becomes "High", "STBY" signal becomes "Low" and motor currents are cut off.

Therefore even in the case of software can not control motors, motors stop automatically for securing safety.

6.7.3. Timing Chart and Wave Form of Motors

6.7.3.1. Timing Chart of Main and FB Motor

1. 2 Phase excitaton

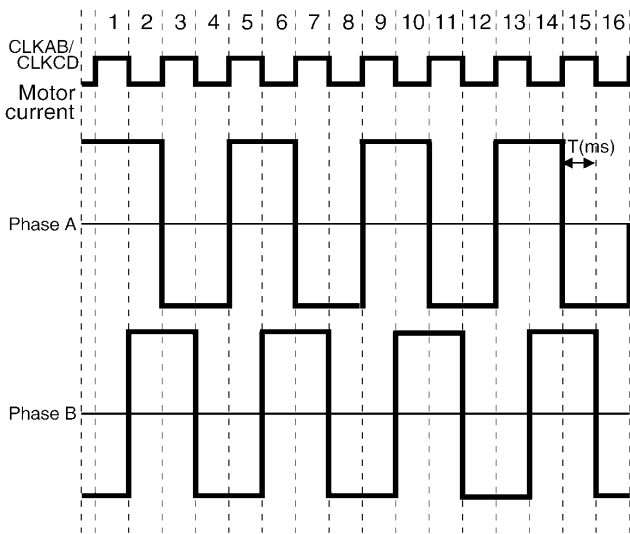

2. Normal Torque 1-2 Phase excitation

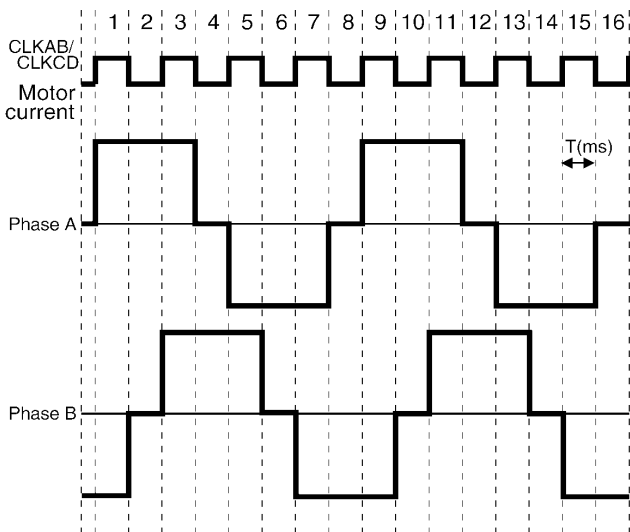

3. Flat Torque 1-2 Phase excitation

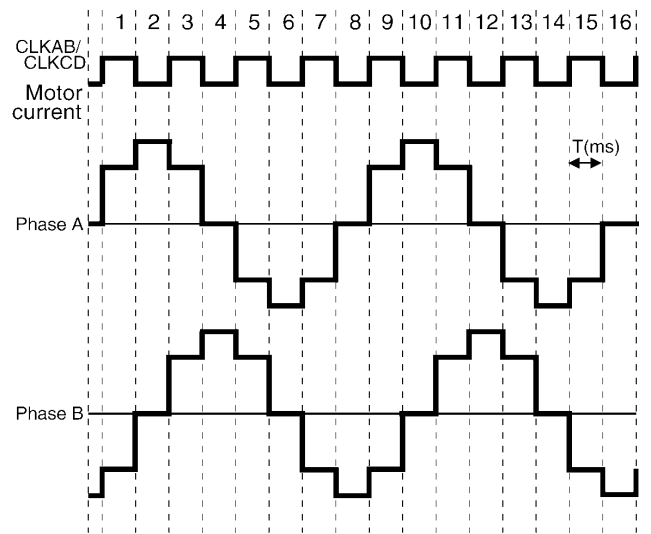

4. W1-2 Phase excitation

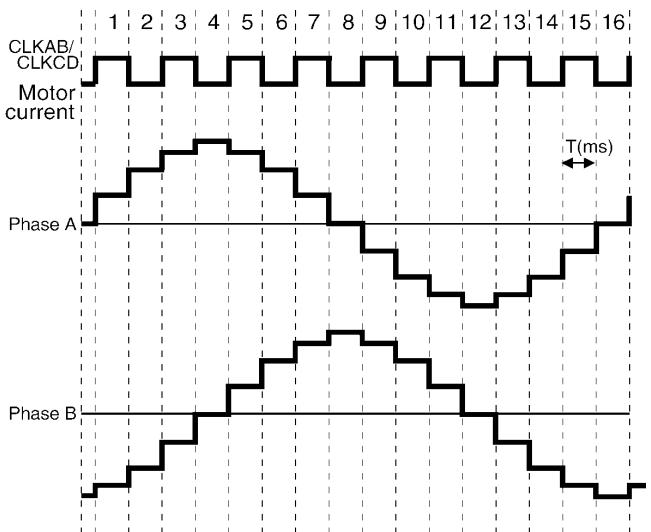

6.7.3.2. Wave Form of Main and FB Motor

1. 2 Phase excitation

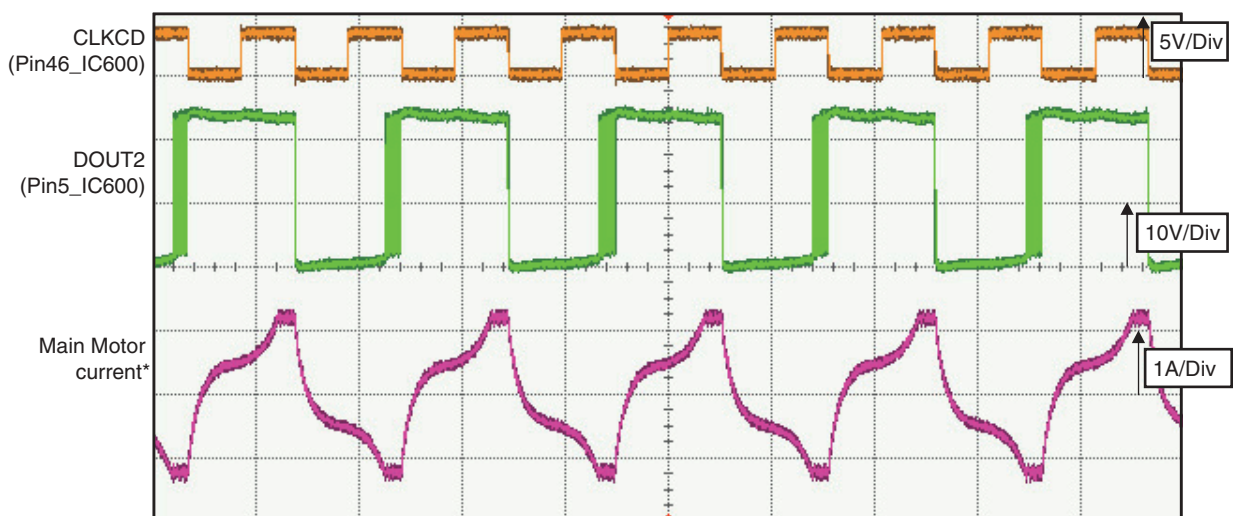
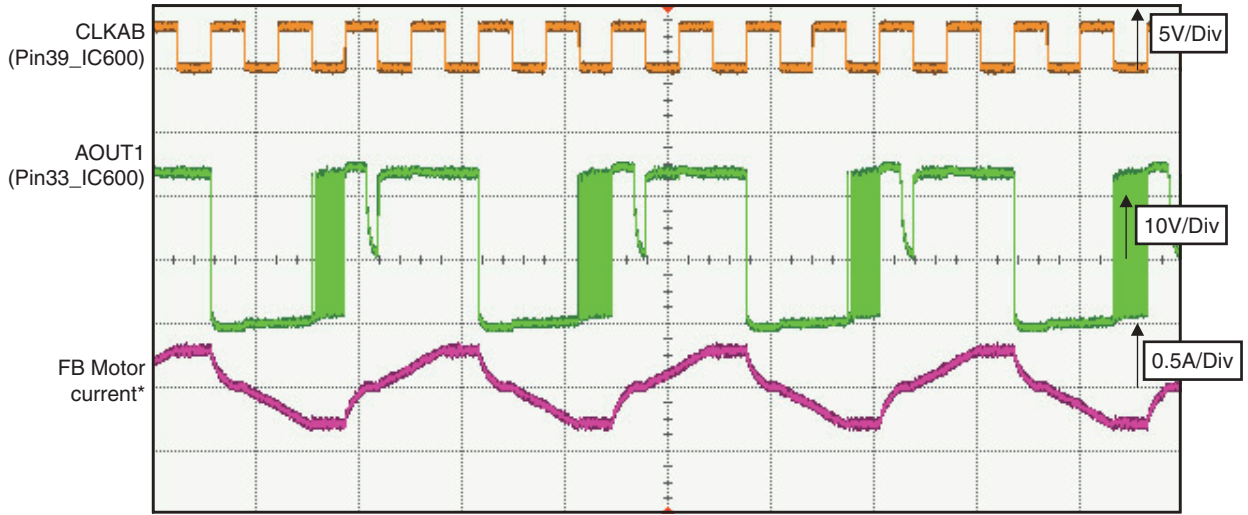

Fig. ①

2. Normal Torque 1-2 Phase excitation



*Motor current is changed according to the motor speed.

Fig. ②

3. Flat Torque 1-2 Phase excitation

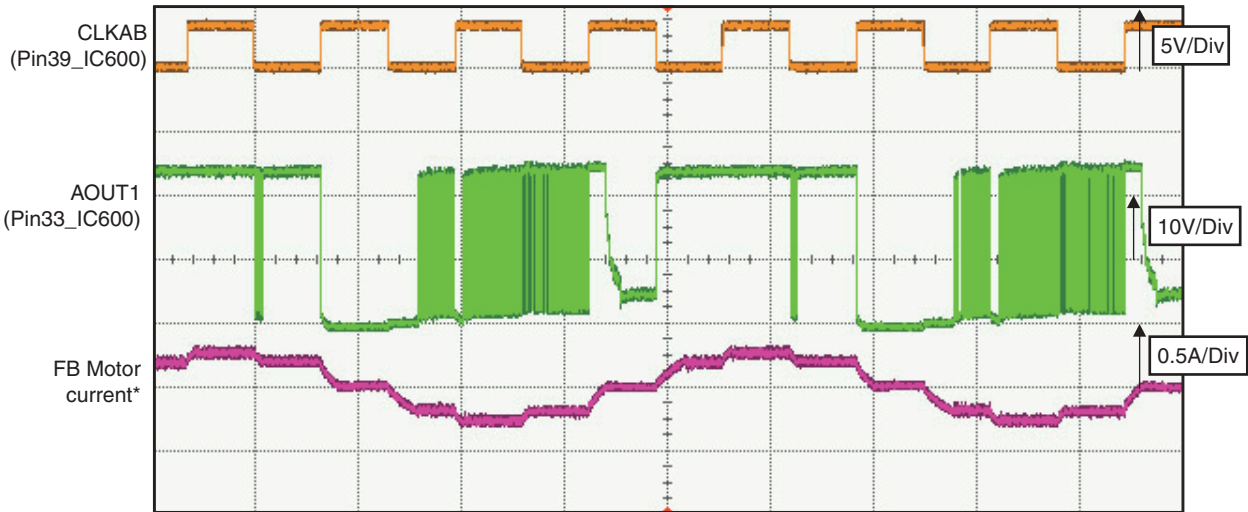

*Motor current is changed according to the motor speed.

Fig. ③

4. W1-2 Phase excitation

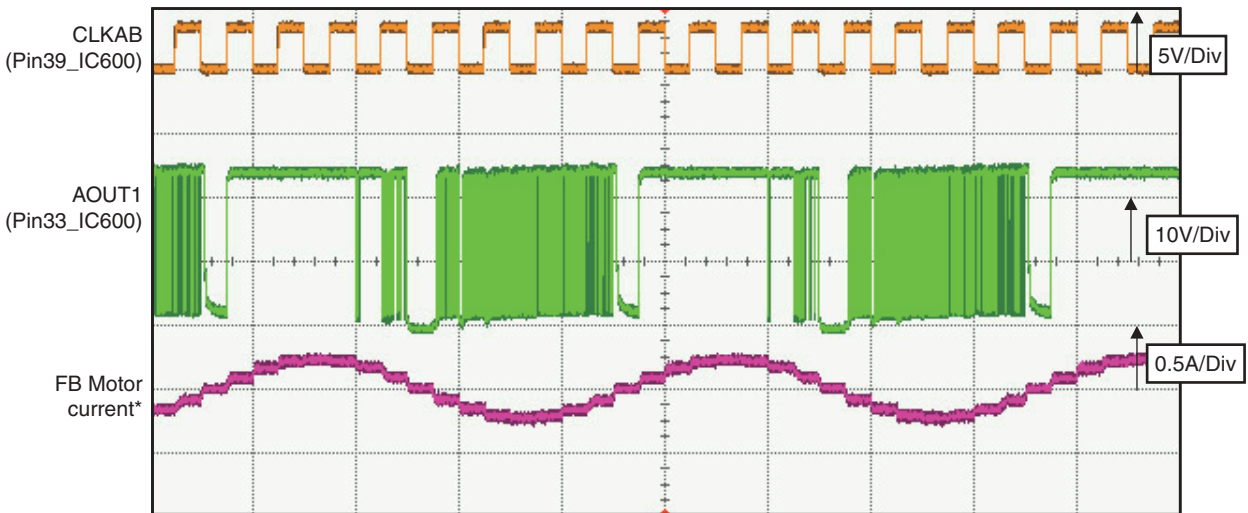

*Motor current is changed according to the motor speed.

Fig. ④

6.7.3.3. Timing Chart of ADF Motor

1. Normal Torque 1-2 Phase excitation

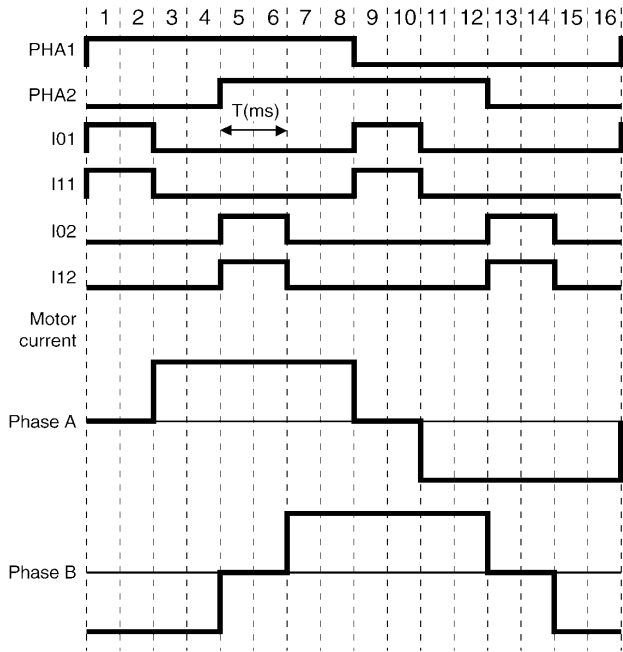

2. Flat Torque 1-2 Phase excitation

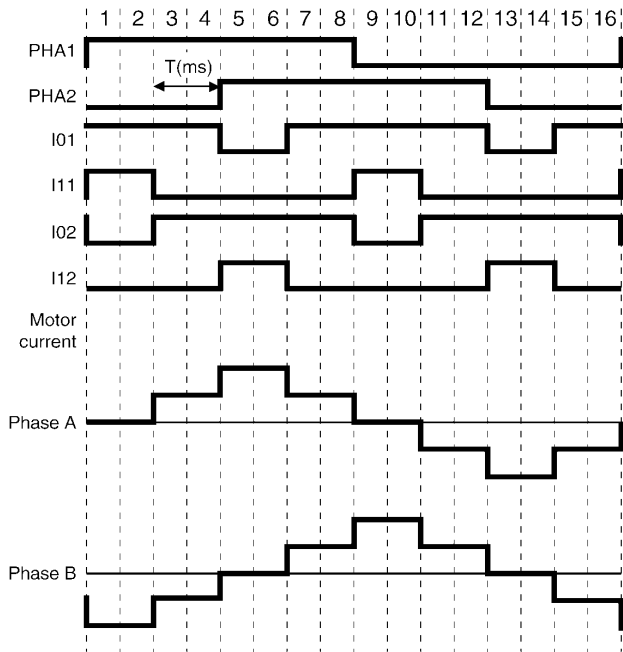

3. W1-2 Phase excitation

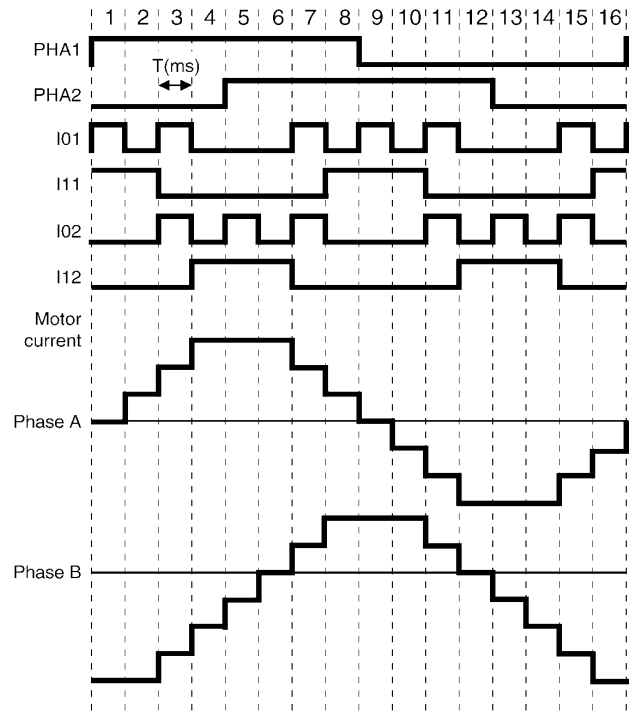

6.7.3.4. Wave Form of ADF Motor

1. Normal Torque 1-2 Phase excitation

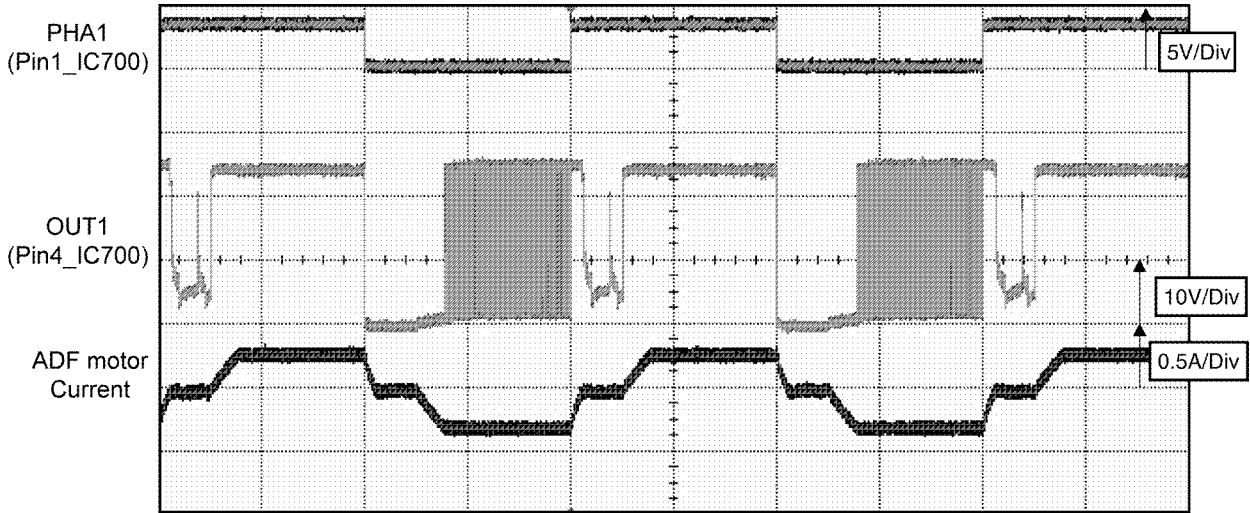

*Motor current is changed according to the motor speed.

Fig. ⑤

2. Flat Torque 1-2 Phase excitation

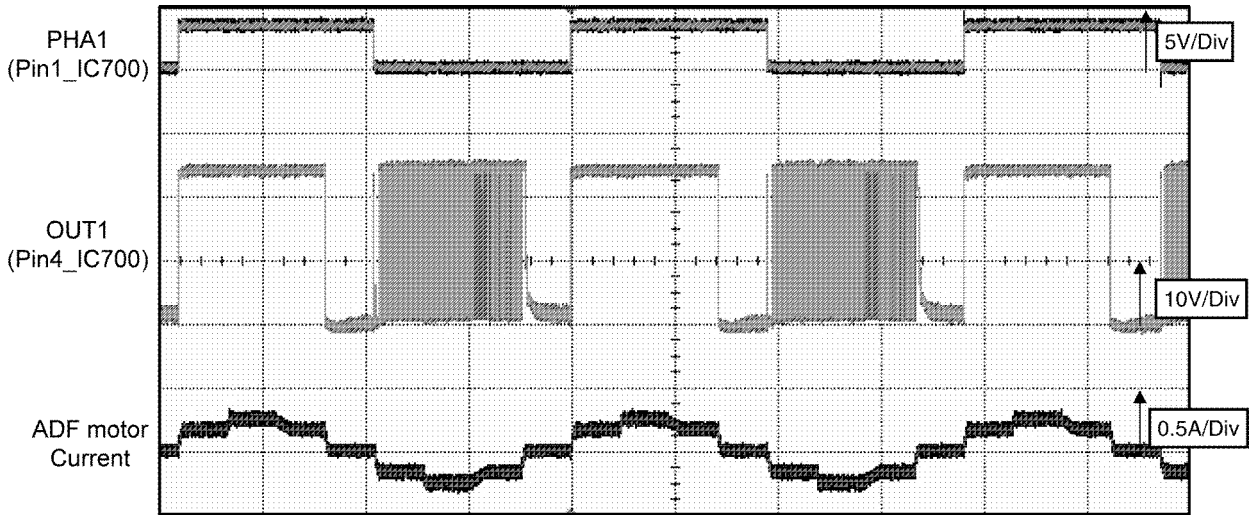

*Motor current is changed according to the motor speed.

Fig. ⑥

3. W1-2 Phase excitation

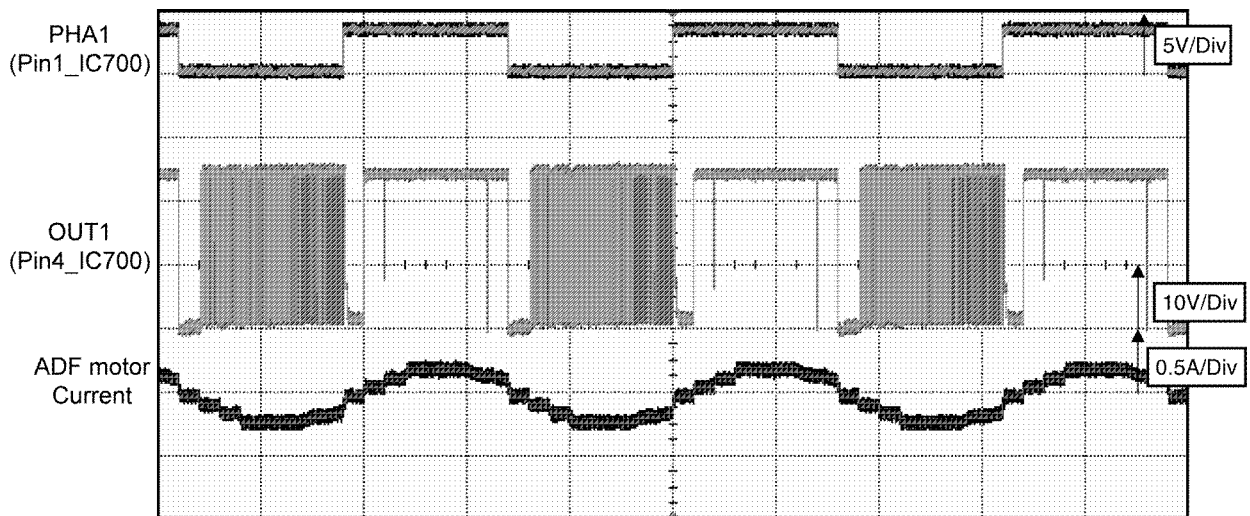

*Motor current is changed according to the motor speed.

Fig. ⑦

6.8. Timing chart and wave form of scanner motors

6.8.1. Drive mode of FB and ADF motor

Correspondent table of operation

Operation	Color mode	ADF/FB	Time & Figure	Resolution (dpi)									
				Pre Scan	75 x 75	100 x 100	150 x 150	200 x 200	300 x 300	400 x 400	600 x 600	1200 x 1200	>2400
PC scan	Color	ADF	T(msec)	0.83					0.61				
			waveform	Fig.4				Fig.5		Fig.6			
		FB	T(msec)	0.28			0.43		0.89		0.90		
			waveform	Fig.3			Fig.4		Fig.5		Fig.6		
	Black & White	ADF	T(msec)	0.29					0.84				
			waveform	Fig.3					Fig.5				
		FB	T(msec)	0.35					0.56		1.25		
			waveform	Fig.2		Fig.3			Fig.4		Fig.5		

Operation	Color mode	ADF/FB	Time & Figure	FAX mode			
				Standard	Fine	Super Fine	Photo
FAX	Black & White	ADF	T(msec)	0.29		0.57	
			waveform	Fig.3		Fig.4	
		FB	T(msec)	0.21		0.42	
			waveform	Fig.3		Fig.4	

Operation	Color mode	ADF/FB	Time & Figure	Copy mode		
				Text	Text/Photo	Photo
Copy	Black & White	ADF	T(msec)	0.29		0.57
			waveform	Fig.3		Fig.4
		FB	T(msec)	0.21		0.42
			waveform	Fig.3		Fig.4

6.8.2. 2 phase excitation

1. Timing chart

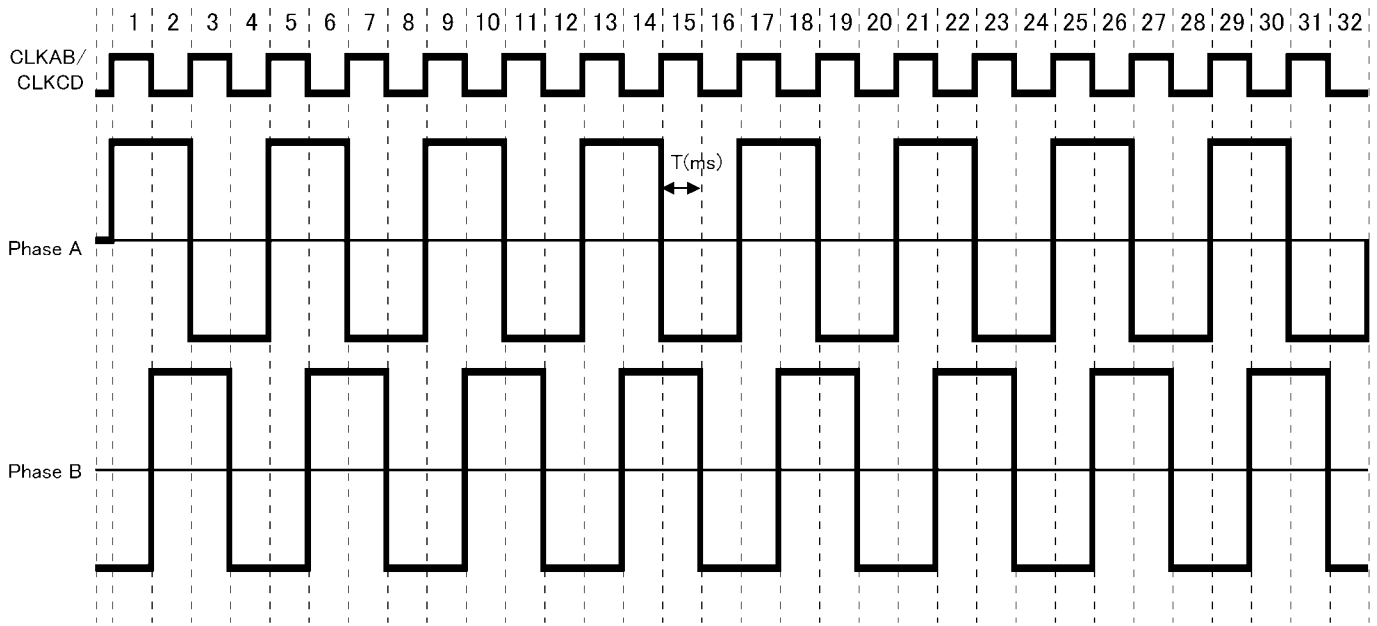

2. Wave form

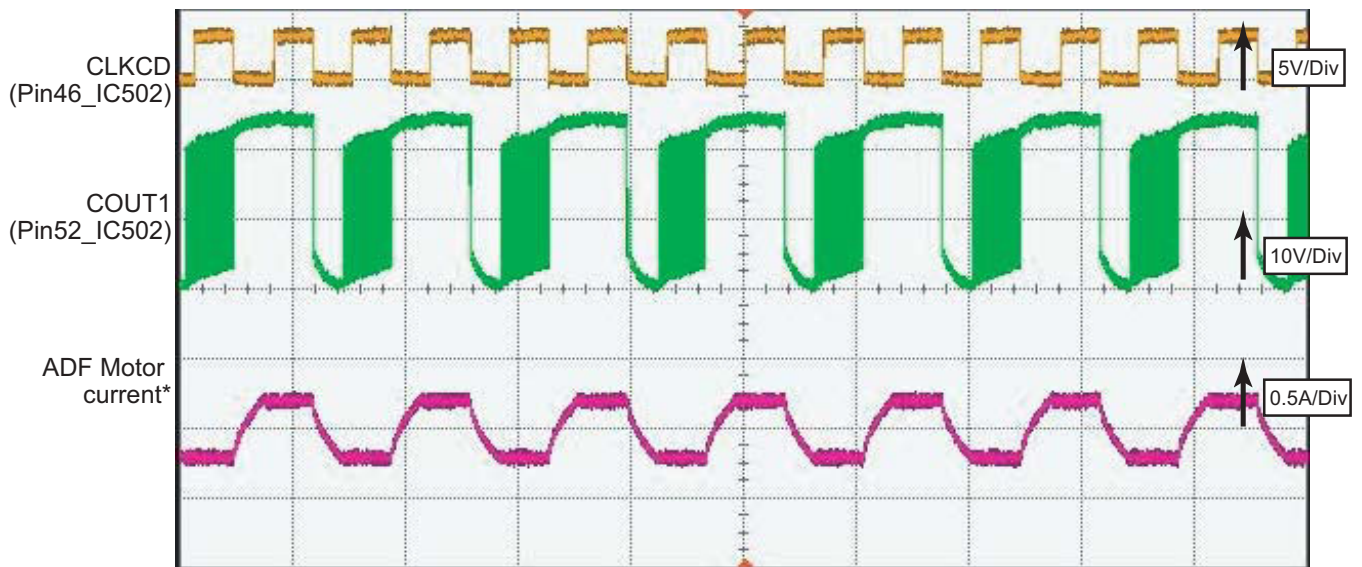
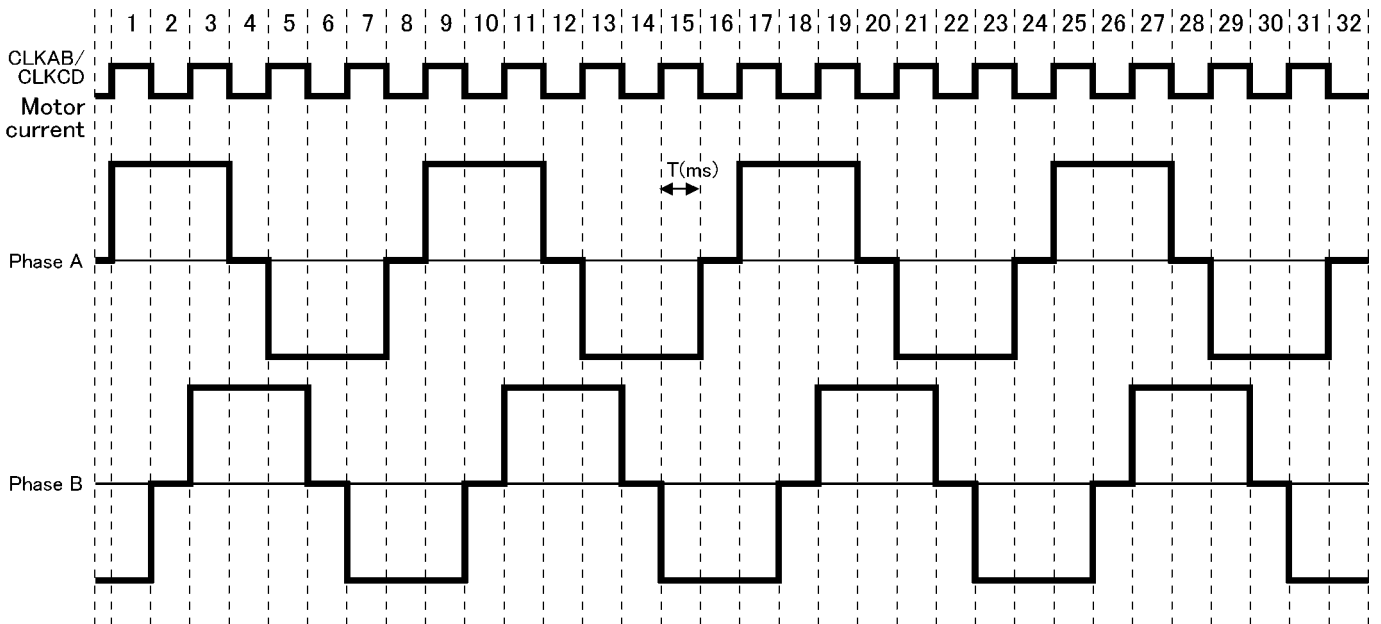

Fig. 2

6.8.3. Normal torque 1-2 phase excitation (half step)

1. Timing chart



2. Wave form example

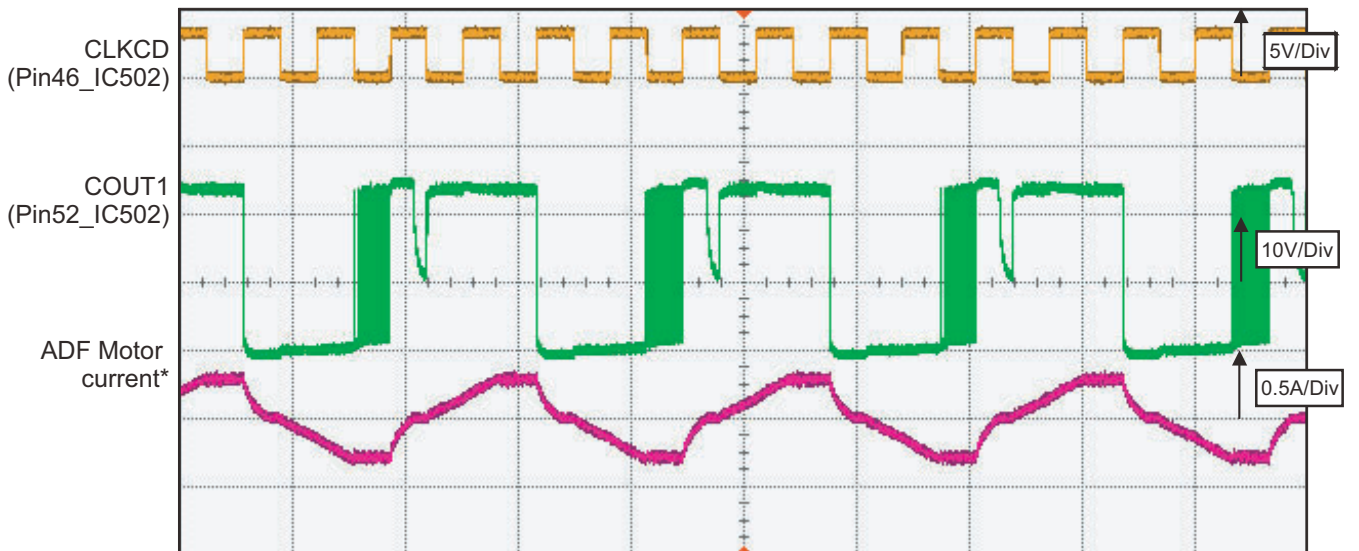
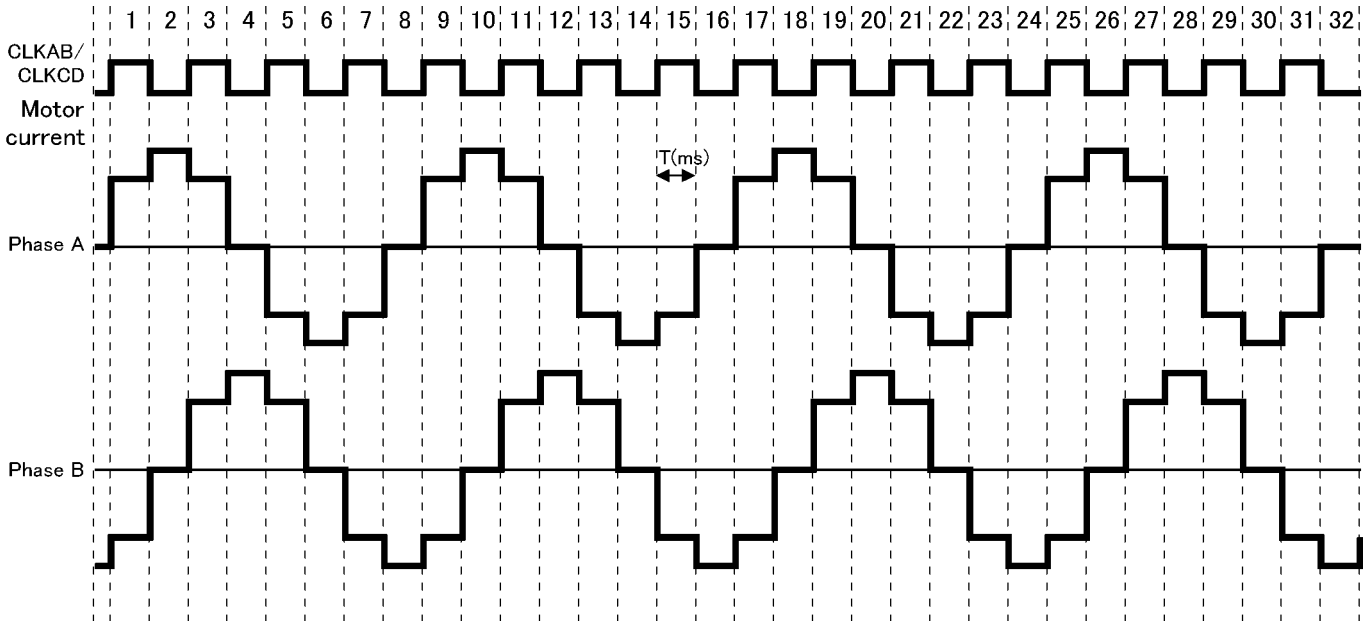

Fig. 3

*Motor current is changed according to the scan speed.

6.8.4. Flat torque 1-2 phase excitation (half step)

1. Timing chart



2. Wave form example

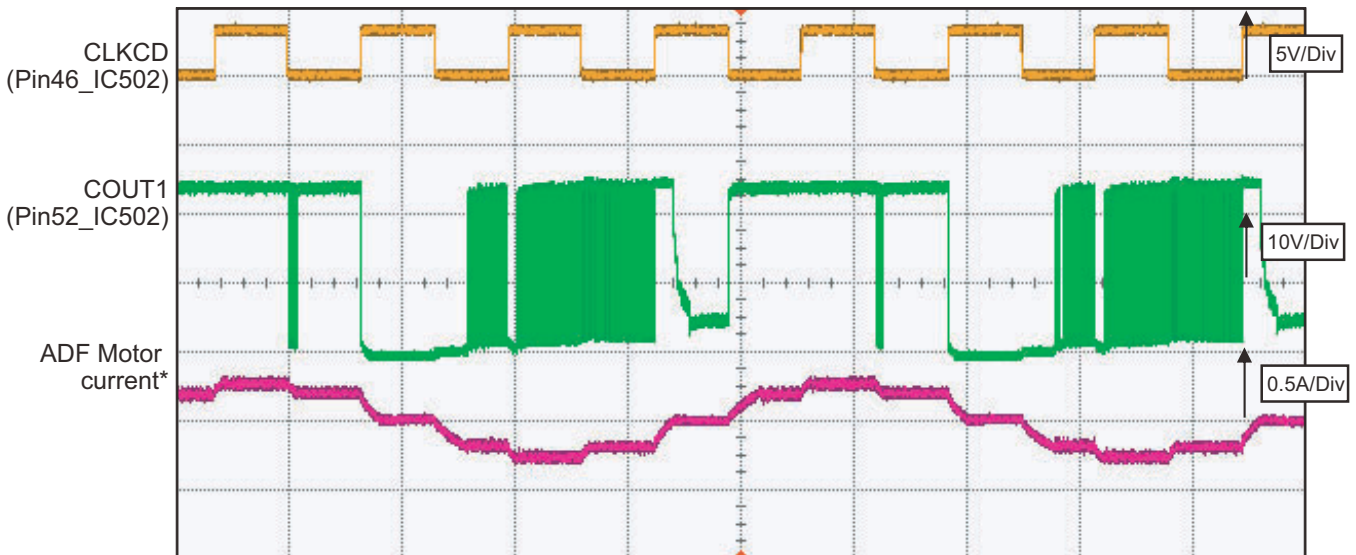
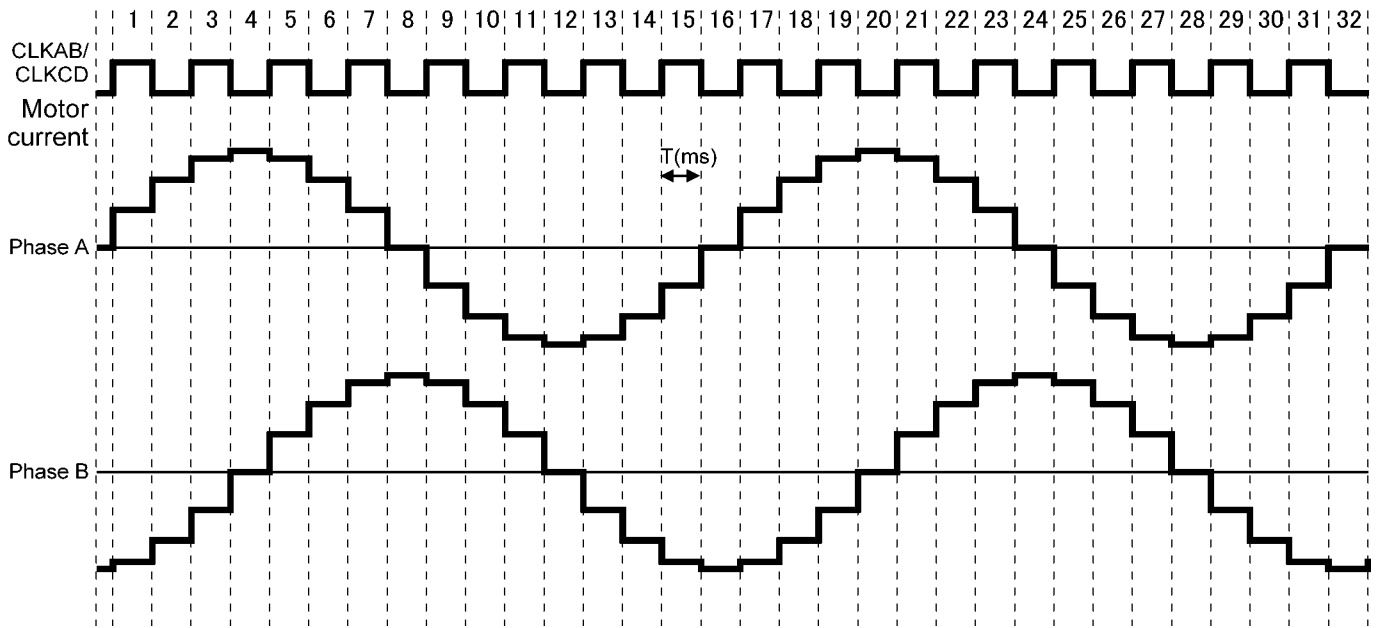

Fig. 4

*Motor current is changed according to the scan speed.

6.8.5. W 1-2 phase excitation (Quarter step)

1. Timing chart



2. Wave form

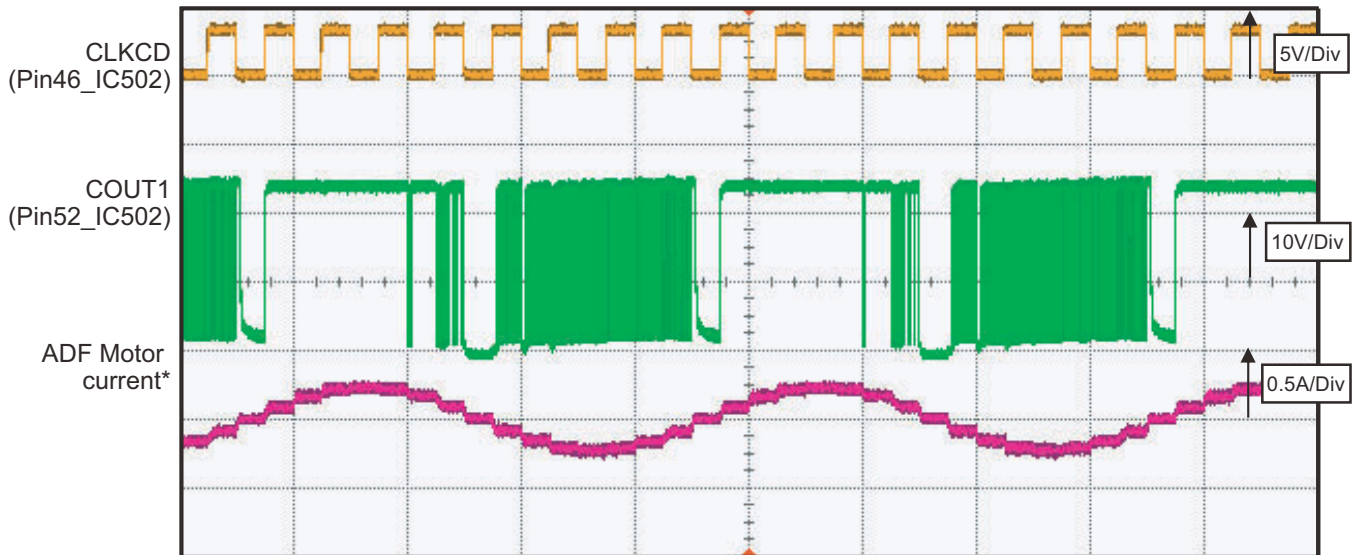
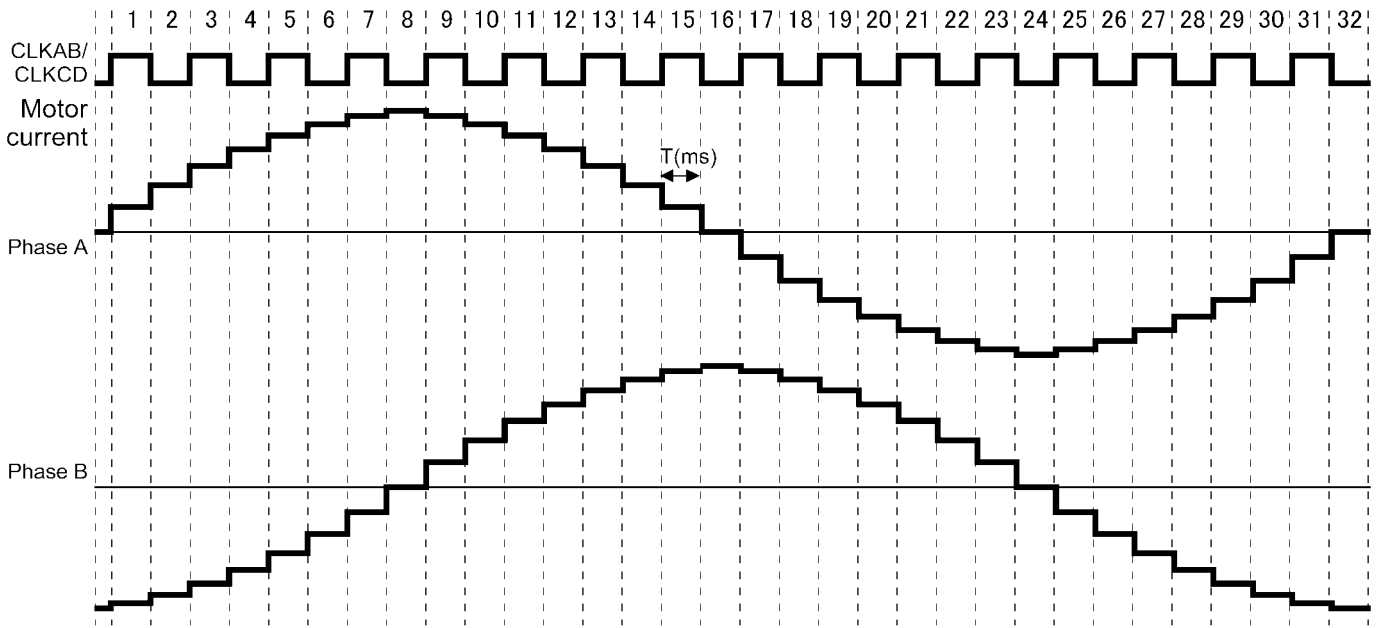

Fig. 5

*Motor current is changed according to the scan speed.

6.8.6. 2W1-2 phase excitation

1. Timing chart



2. Wave form

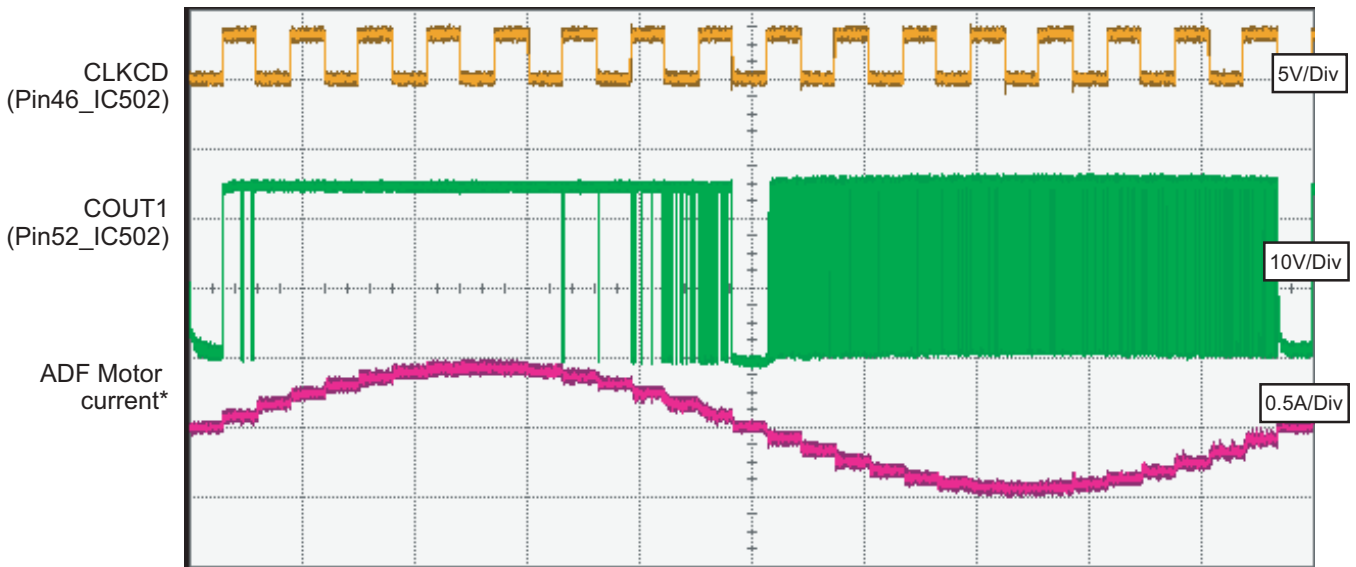

Fig. 6

6.9. FAN Motor Section

6.9.1. General

This unit is equipped with two FAN motors to prevent the developing devices, Low Voltage Power Supply board (SMPS Board) and other devices from overheating during printing.

The FAN rotates at high speed (Approx. 3000rpm) while printing.

After printing is finished, FAN rotates at low speed (Approx.2200rpm) while predetermined period.

6.9.2. Circuit Diagram of FAN

Two FAN motors are controlled by following one circuit.

Depending on a model, the number of fans is one.

So the operation of two FAN motors (Full speed rotation/Half speed rotation/Stop) are controlled simultaneously.

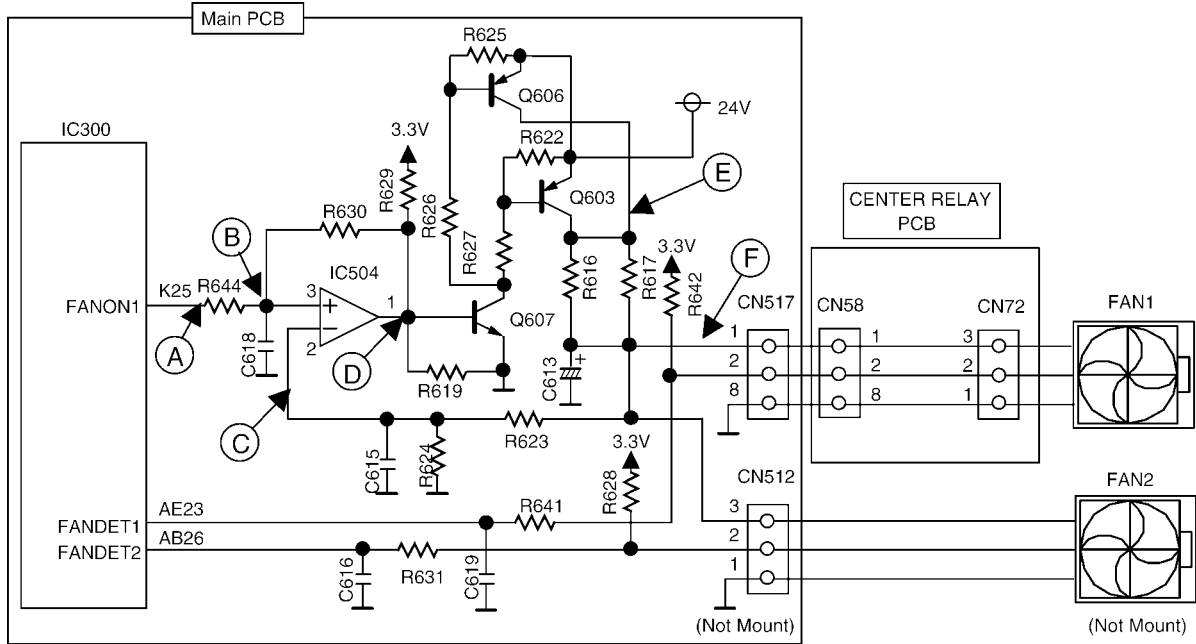

6.9.3. Fan Control

For the control of FAN speed, comparator IC (IC504) is used.

This IC compares (+) side input level and (-) side input level.

If (+) side input level is bigger than (-) side input level, output of this IC is "OPEN".

If (+) side input level is less than (-) side input level, it outputs "L" level.

6.9.3.1. Half Speed Mode

In half speed mode, IC300_pin K25 outputs pulse (frequency is about 30KHz, duty is about 37.5%).

This pulse is integrated by R644 and C618 then Pin2_IC504 becomes approx. DC1.24V. Input level of IC504_pin2 is determined by the voltage of between R624.

If voltage between R624 is less than 1.24V, output of pin1_IC504 becomes "H".

Then both Q606, Q607 and Q603 are turned on. So voltage between R624 (=the voltage of pin2_IC504) rises gradually.

When the voltage between R624 exceeds 1.24V, output of pin1_IC504 becomes "L".

Then both Q606, Q607 and Q603 are turned off. So voltage between R624 falls gradually.

By repeating these sequences, voltage between R624 is controlled approx. 1.24V.

On the other hand, if FAN voltage is represented V_o and voltage between R624 is represented V_L , V_L is determined as below formula.

$$V_L = V_o \cdot R_{624} / (R_{623} + R_{624}) \rightarrow V_o = V_L \cdot (R_{623} + R_{624}) / R_{624}$$

Since each value is as follows, V_o is determined approx. 9.7(V).

$$V_L = 1.24(V), R_{623} = 150(Kohm), R_{624} = 22(Kohm)$$

$$V_o = 1.24 \cdot (150K + 22K) / 22K = 9.7(V)$$

Therefore by reducing the voltage of FAN power supply, FAN rotates with half speed.

6.9.3.2. Full Speed Mode

In full speed mode, IC300_pinK25 outputs constant 3.3V.

When Q606, Q607 and Q603 are turned on, Vo becomes approx 20V (approx.4V drops between R616, R617).

So the voltage between R425 is determined as follows

$$V_L = V_o * R_{624} / (R_{623} + R_{624}) = 20 * 22K / (150K + 22K) = 2.5(V)$$

Since IC504_pinA3 is 3.3V and IC504_pinA2 is 2.5V, pin1_IC504 is always "H".

Consequently all Q606, Q607 and Q603 are always turned on, and then approx 20V is supplied to FAN motors.

Therefore FAN rotates with full speed.

6.9.3.3. FAN stop

When IC300_pinK25 is "L", both Q606, Q607 and Q603 are turned off, then both FAN stop rotation.

6.9.3.4. Rotation detect signal

During the FAN rotation, the pulse signal is output from pin 2 of FAN motors as the rotation detects signals.

If the period of the pulse is wider than predetermined value, it is judged that FAN error occurred.

Then display shows "Call Service 4".

6.9.4. Control table

FANON1H (IC300_pinK25)	FAN1and FAN2 mode
H	Full speed
Pulse	Half speed
L	Stop

6.9.5. Waveform

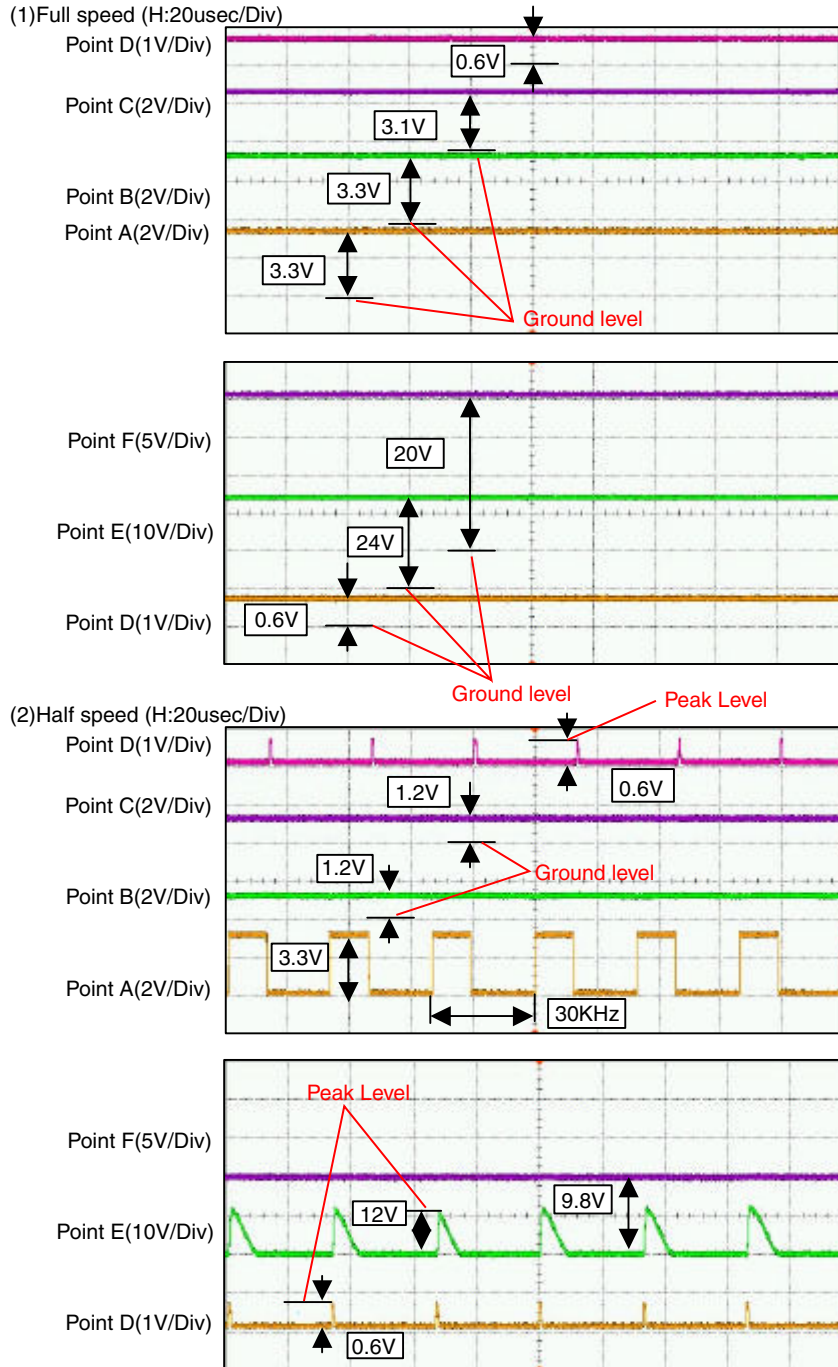

6.9.6. Abnormal Detect and Lock Protect Block

This block detects the FAN abnormal condition such as FAN motor lock or Extra low current caused by insufficient connector insertion of FAN.

When FAN motor abnormal condition occurs, it may cause damage to FAN itself and machine by the overheat.

So at the abnormal condition, FAN motor current must be stopped automatically and machine operation must be stopped.

When error condition is detected, display shows "Call Service 4"

6.9.6.1. FAN motor Lock detect and protection

When FAN motor is locked, motor current becomes much more than normal condition.

So the voltage between R616 becomes bigger than normal condition, and this causes Q606 turns on.

After turning on of Q606, the base voltage of Q608 rises gradually due to the integration effect of R634, R628 and C616.

If FAN motor lock condition continues over 4 seconds, base voltage of Q608 reaches to 0.7V, and Q608 turns on.

Once Q608 turns on, Q610 and Q609 turns on consequently.

By turning on of Q609, input level of IC504_pin2 becomes less than 0.4V and Q607 is turned off.

Therefore no current is supplied to FAN motor.

Due to the turning off of Q607, Q606 is turned off accordingly.

But the combination of Q610 and Q608 keep the on condition of Q608 even after turning off of Q606.

As the result after approx. 4 seconds of FAN motor lock, no current is supplied to FAN motor.

At the same time when Q608 is turned on, FANDET1 signal (IC300_pinAE23) becomes from "H" to "L".

By checking FANDET1 signal, IC300 recognizes that FAN error occurred.

This condition is maintained until FAN motor lock condition is eliminated and power off/on of machine.

6.9.6.2. Extra low current detection

When connector insertion is insufficient or FAN/FAN lead broken, no current flows to the FAN motor.

In the normal condition, since current flows through R616, Q603 turns on.

During Q603 on condition, Q603 does not affect Q606 operation.

But when current does not flows through R616, Q603 turns off.

Once Q603 turns off, base current of Q606 flows through R626 and R627, then Q606 turns on.

The sequence after turning on of Q606 is same as described in FAN motor Lock detect and protection.

After approx. 4 seconds Q606, Q608, Q609 and Q610 are all turn on, consequently FANDET1 signal becomes "L".

By checking FANDET1 signal, IC300 recognizes that FAN error occurred.

This condition is maintained until FAN becomes normal condition and power off/on of machine.

6.10. Solenoid Driver Section

The solenoid drive circuit controls Registration clutch, Pick up solenoid, ADU solenoid, Switch back solenoid and MPT pick up solenoid.

When duplex scanning, this circuits controls ADF solenoid and ADF switch back solenoid.

These solenoids are designed to be driven 24V.

The diodes protect transistors from reverse generated voltage when solenoids are turned off.

1. Circuit Diagram

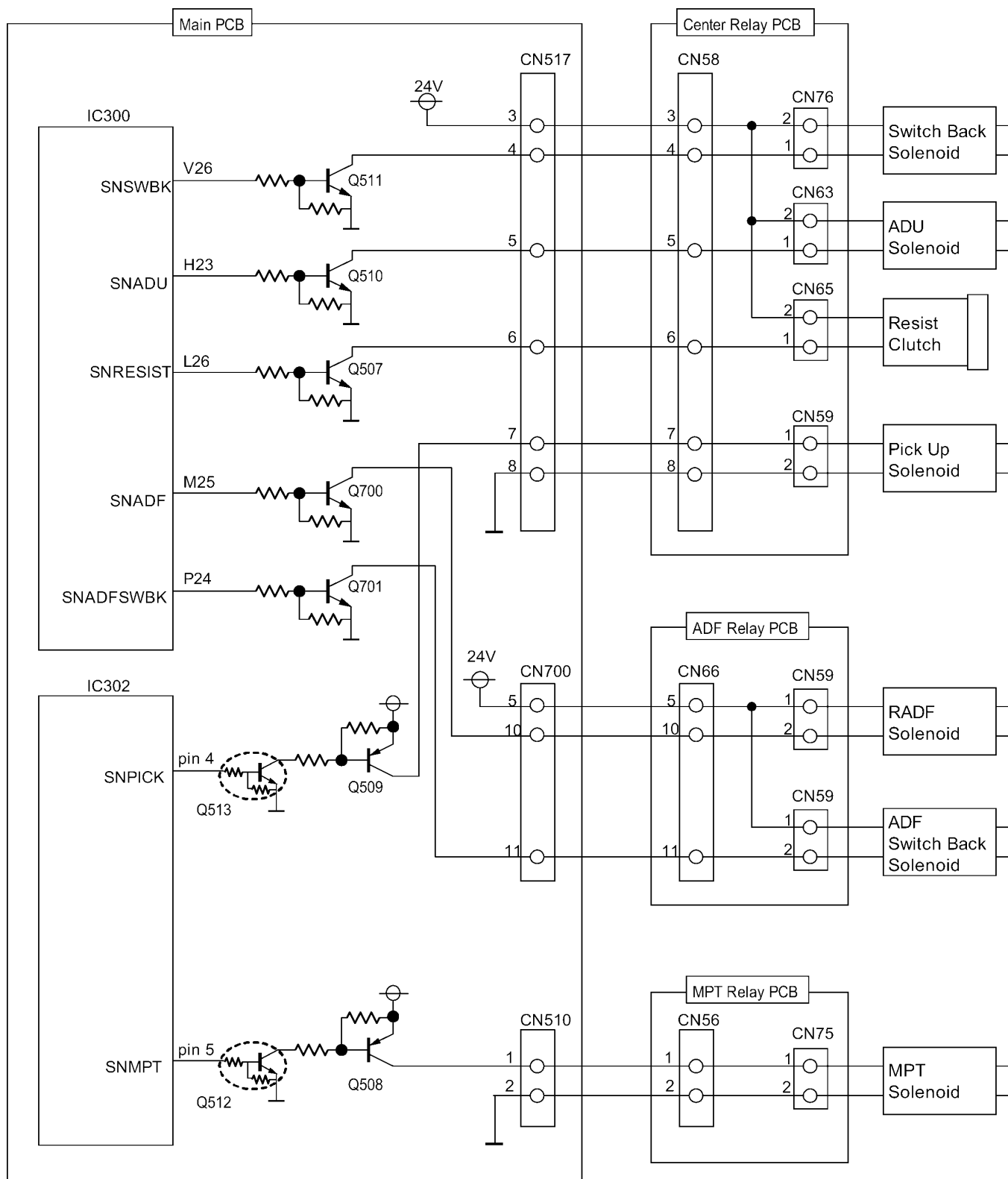

2. Active Logic

SWITCH BACK	
MODE	IC300_V26
Solenoid ON	High level
Solenoid OFF	Low level

ADU	
MODE	IC300_H23
Solenoid ON	High level
Solenoid OFF	Low level

RESIST	
MODE	IC300_L26
Clutch ON	High level
Clutch OFF	Low level

RADF	
MODE	IC300_M25
Solenoid ON	High level
Solenoid OFF	Low level

ADF SWITCH BACK	
MODE	IC300_P24
Solenoid ON	High level
Solenoid OFF	Low level

PICKUP	
MODE	IC302_pin4
Solenoid ON	High level
Solenoid OFF	Low level

MPT	
MODE	IC302_pin5
Solenoid ON	High level
Solenoid OFF	Low level

6.10.1. Optional Lower input Tray Motor (OPF Motor) Drive and Solenoid Drive circuit

6.10.1.1. General

This MFP can add Optional Lower input Tray for improving the performance.

OPF motor feed the paper in this tray to the registration roller.

OPF motor drive circuit is consist of motor drive IC (IC950), current control circuit.

6.10.1.2. Circuit Diagram

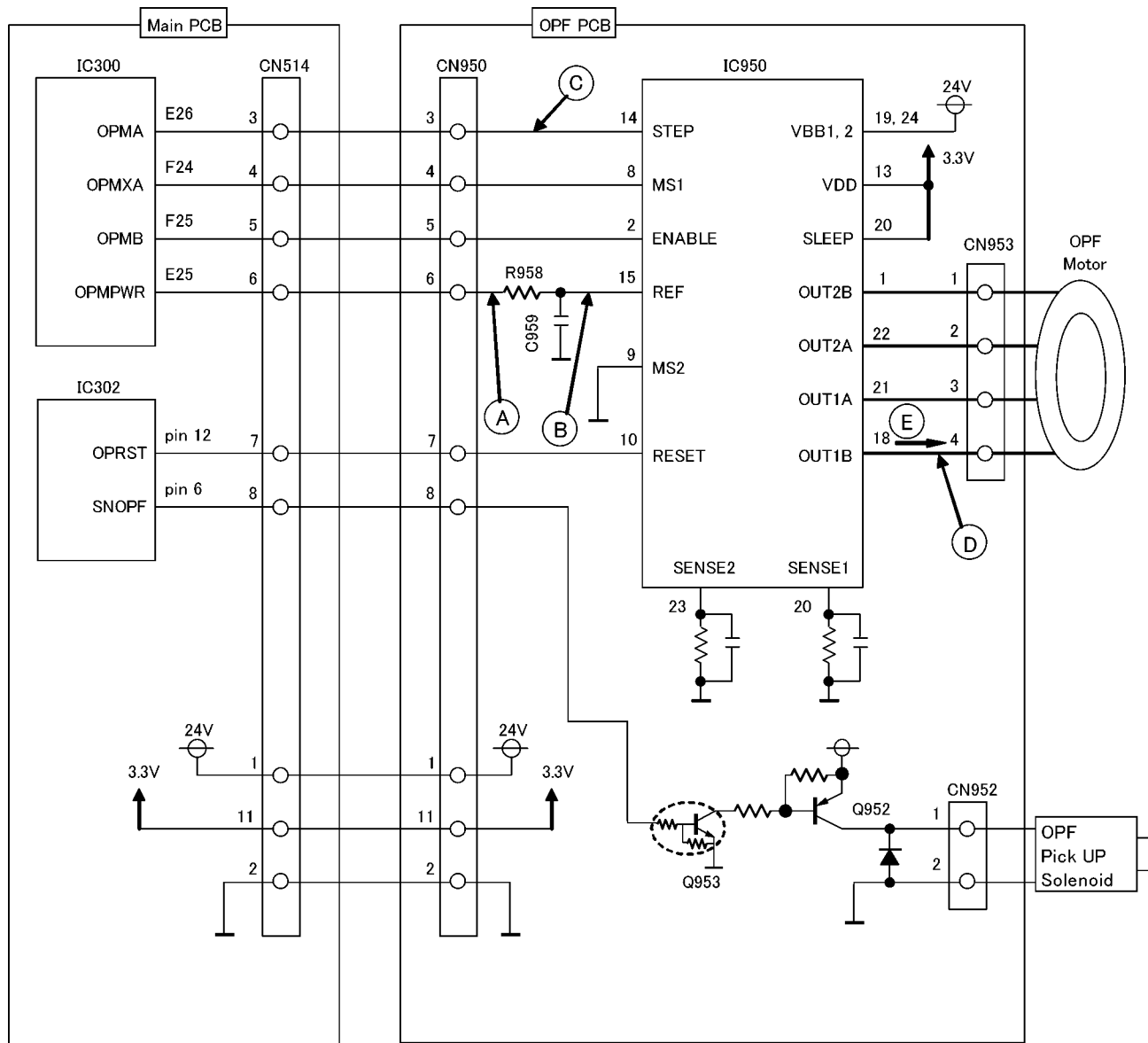

3. Explanation of each circuit

1. Motor driver

IC950 is the constant current, Bi-polar stepping motor drive IC.

This IC can drive up to 2A/phase and support up to 2W1-2 phase excitation.

When "enable" signal (IC950_pin2) becomes "L", motor driver is activated, and motor current are supplied from IC950_pin1, pin18, pin21 and pin22 to drive the motor coil.

Excitation type is selected by the logic level of "MS1"(IC950_pin8) and "MS2"(IC950_pin9).

MS2 of this circuit is fixed "Low" level.

The operation of IC950 is shown in below table corresponding to each logic level of enable, MS1, and MS2.

Enable (IC950_pin2)	MS1 (IC950_pin8)	MS2 (IC950_pin9)	Excitation type	Motor Operation
H	-	-	Disable	Motor stop
L	L	L	2 Phase Excitation	Full speed operation
L	H	L	F1-2 Excitation	Half speed operation

After setting the above signals, clock signal is supplied from IC300_pin E26 to IC950_pin14.
 Whenever clock signal is supplied, current value and direction supplied to Main motor change according to the excitation type which is determined by above signal levels.
 The clock frequency also determines the motor speed.

2. Motor current control circuit

According to the rotation speed, motor current is controlled for appropriate value.
 In order to control the motor current, Ref voltage of IC600 is controlled.
 When Ref voltage is high, motor current is increased, and the voltage is low, motor current is decreased.

For the control of Ref voltage, PWM pulse is supplied from IC300_pin E25.
 PWM pulse is integrated by R958 and C959.
 Consequently PWM pulse is converted to DC voltage.
 When duty of PWM pulse is high, Ref voltage is increased and when duty is low, Ref voltage is decreased.

3. Solenoid control circuit

The solenoid drive circuit controls Pick up solenoid.
 These solenoids and clutch are designed to be driven 24V.
 The diodes protect transistors from reverse generated voltage when solenoids are turned off.

OPF PICKUP	
MODE	IC302_pin6
Solenoid ON	High level
Solenoid OFF	Low level

4. Explanation of each circuit

(1) Full speed mode Duty=80.0%

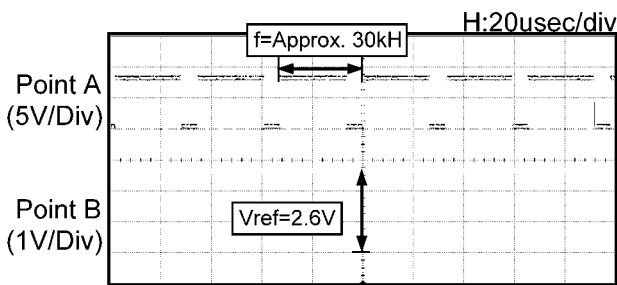

(2) Half speed mode Duty=56.6%

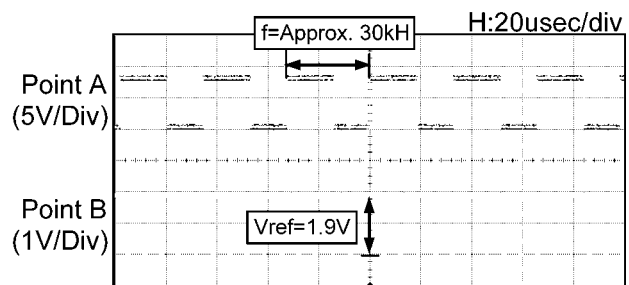

5. Timing chart and wave form of Main motors

1. 2-2 phase excitation (Full speed)

(1) Timing chart

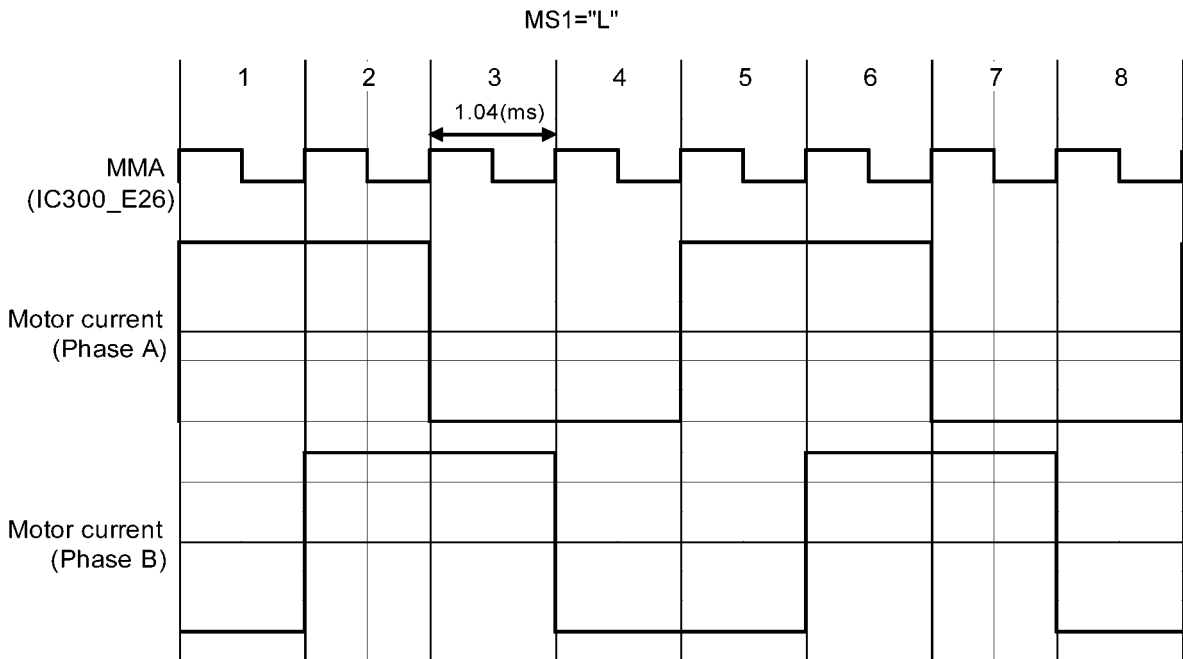

(2) Wave form

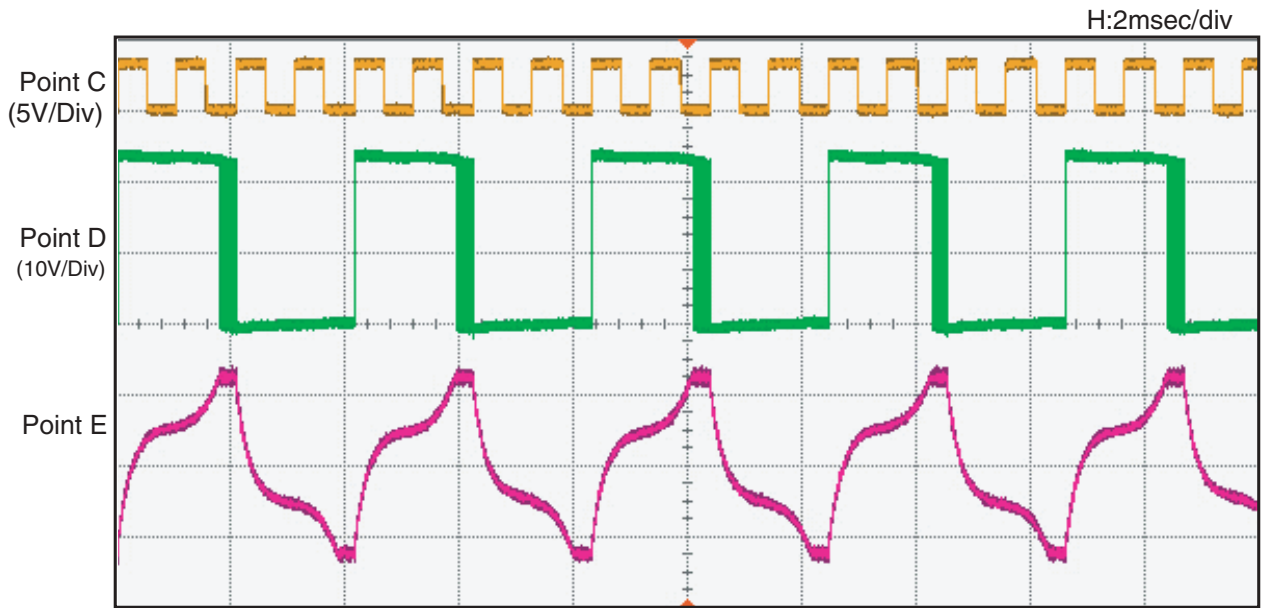

2. Flat torque 1-2 phase excitation (Half speed)
 (1) Timing chart

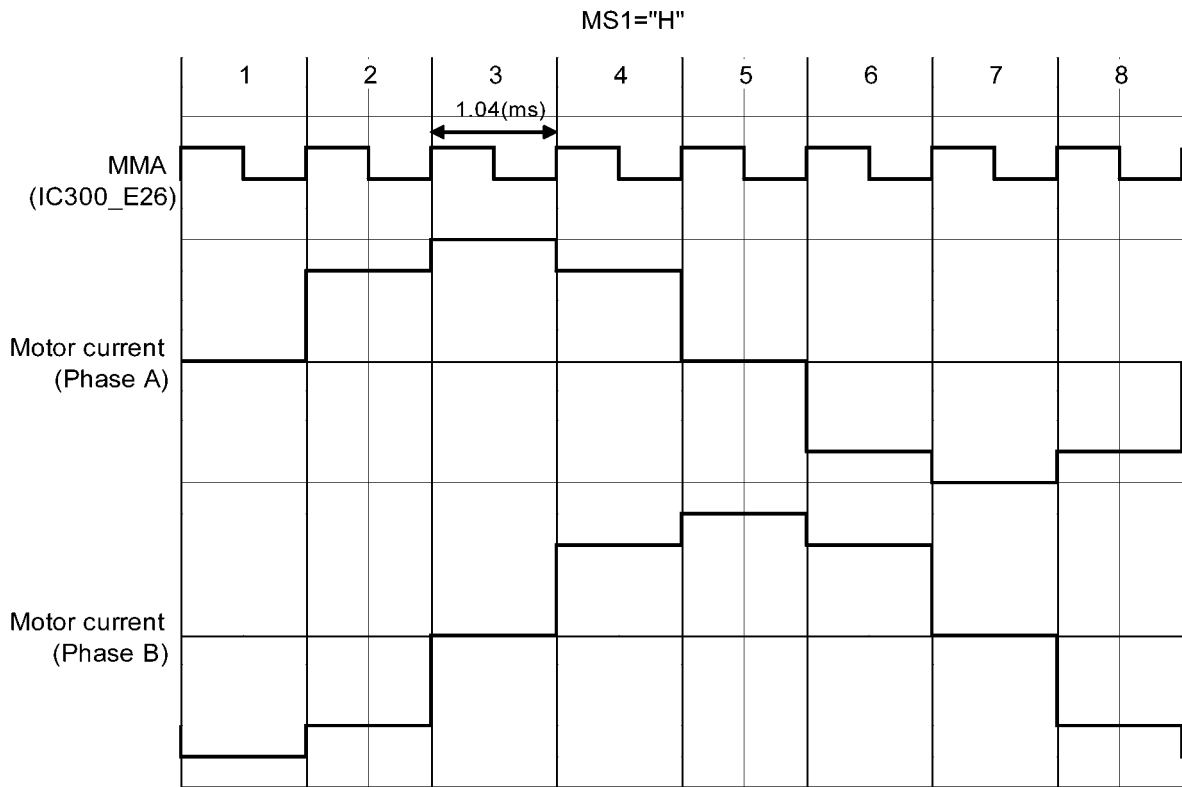

(2) Wave form

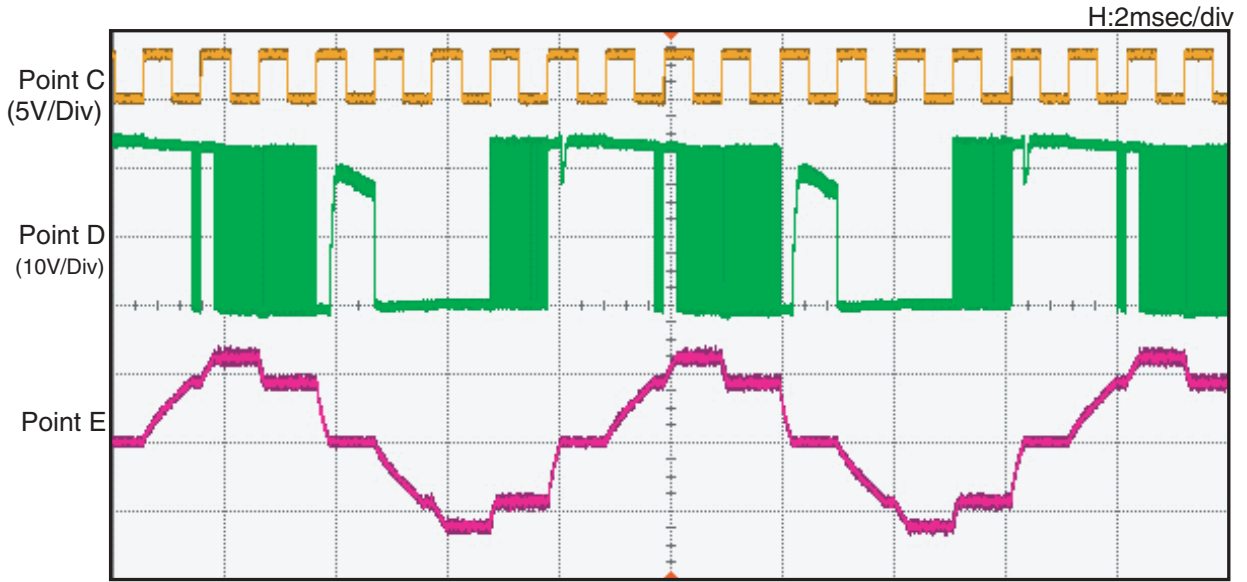

6.11. LSU (Laser Scanning Unit) Section

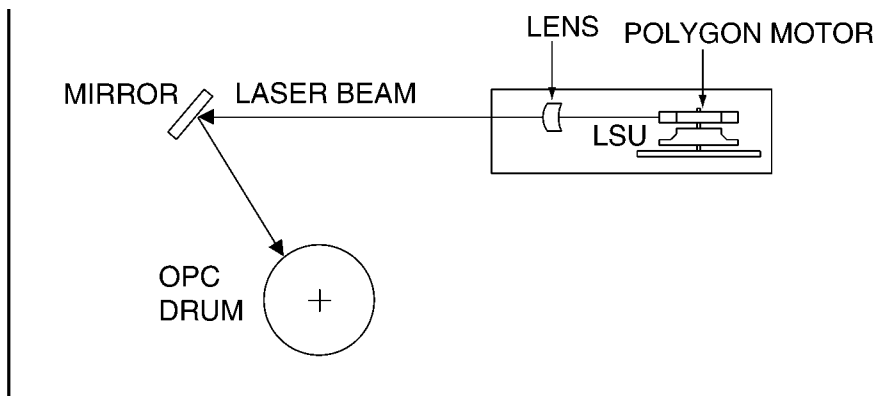

The mechanical shutter will be opened by setting DRUM UNIT properly.

LSU Layout

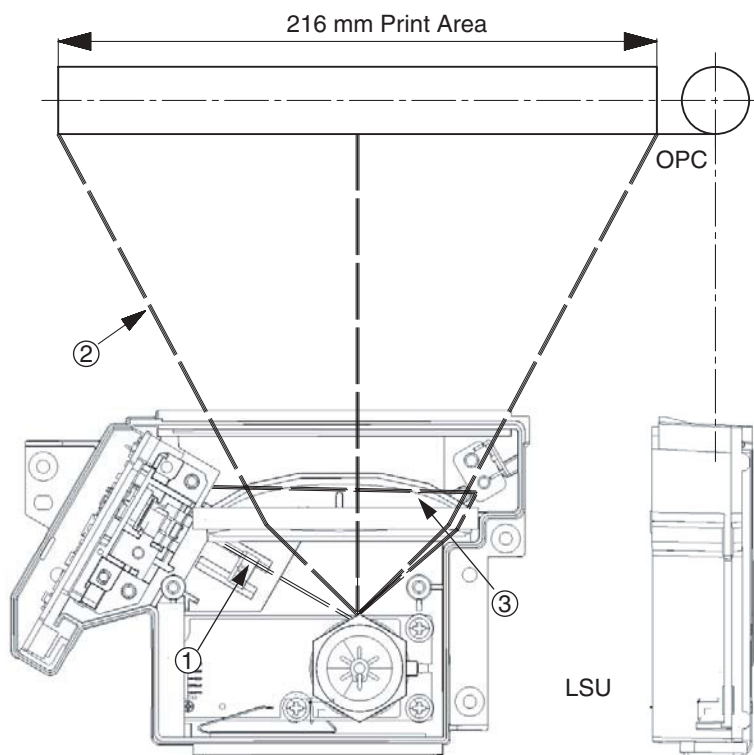

- ① Laser output
- ② OPC DRUM is irradiated with a laser.
- ③ The sensor outside the effective printing area detects the 1-line operation (scanning).

Circuit Diagram

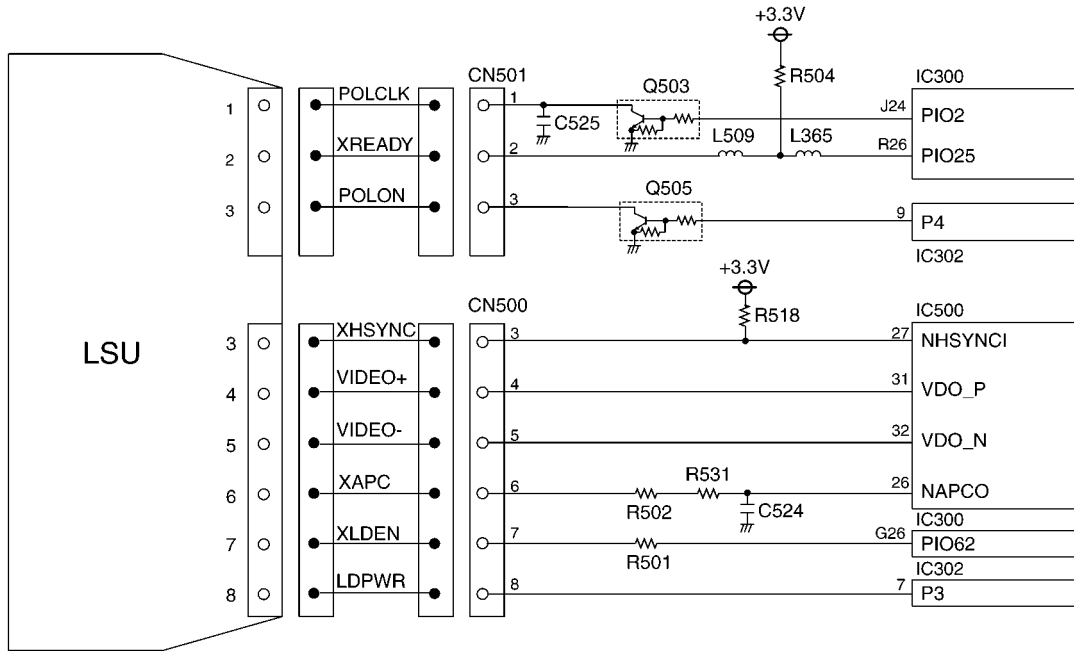

Timing Chart

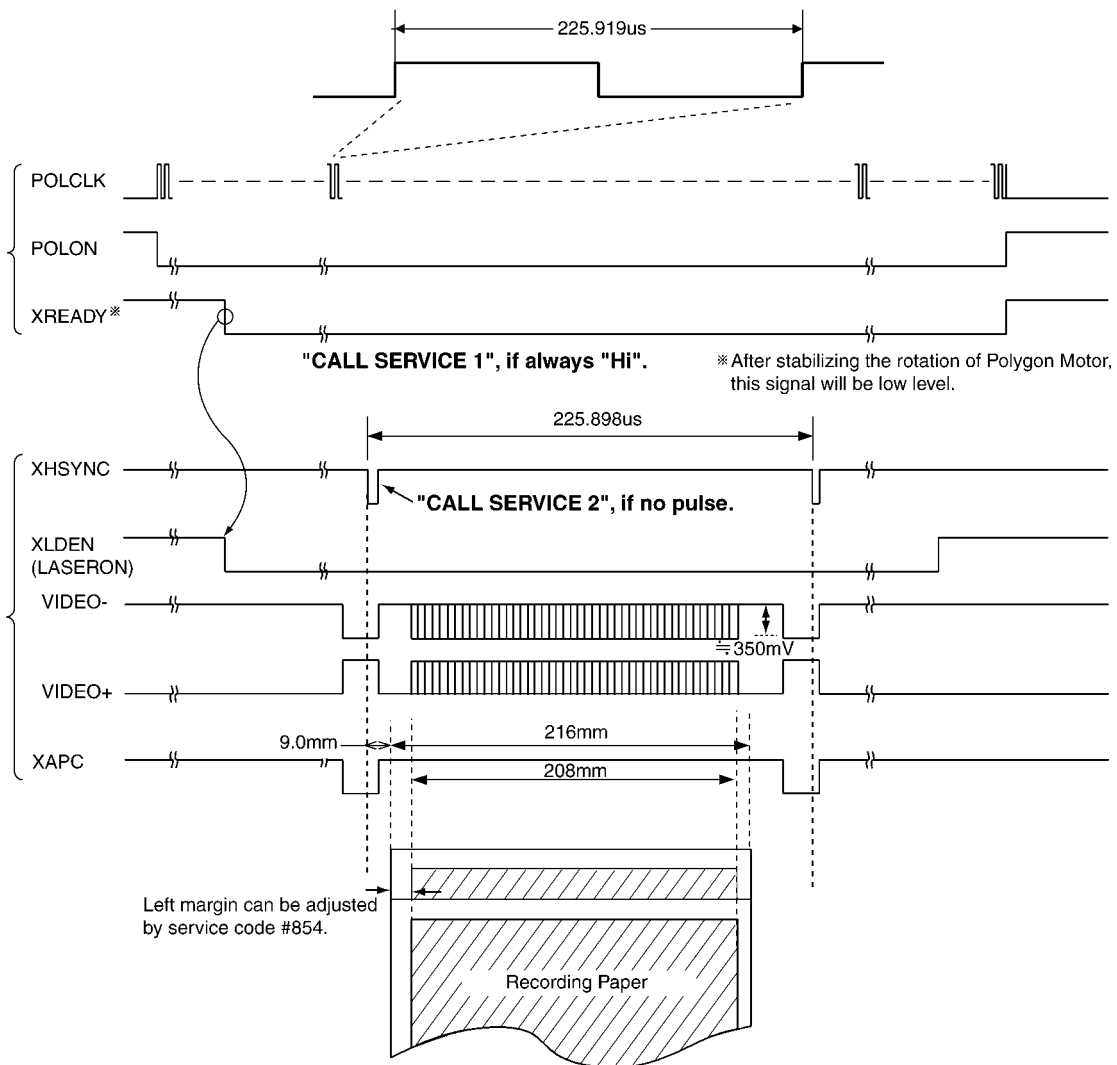

6.12. Sensors and Switches Section

All of the sensors and switches are shown below.

Sensor Name	Sensor Location	Reference number	Message Error
Pick sensor	Pick up relay Board	PI50	[PAPER JAMMED]
Resist sensor	Print sensor relay Board	PI54	[PAPER JAMMED]
PTOP sensor	Print sensor relay Board	PI55	[PAPER JAMMED]
ADU sensor	Print sensor relay Board	PI53	[PAPER JAMMED]
Exit sensor	FUSER Board	PI58	[PAPER JAMMED]
Document sensor	Document sensor Board	PI60	[REMOVE DOCUMENT]
Read position sensor	RPS Board	PI59	[REMOVE DOCUMENT]
RADF JAM sensor	RADF Board	PI62	[REMOVE DOCUMENT]
MPT sensor	MPT Relay Board	PI61	[PAPER JAMMED]
Paper sensor	Pick up relay Board	PI51	[OUT OF PAPER]
CSopen sensor	Pick up relay Board	PI52	[CHECK INSTALL INPUT TRAY#1]
Rear cover sensor	Rear sensor Board	PI57	[OPEN REAR COVER]
Interlock switch	Interlock switch Board	SW50,SW51	[FRONT COVER OPEN]
Toner sensor	Toner Sensor Board	IC50	[TONER LOW CHANGE SUPPLIES] [TONER EMPTY CHANGE SUPPLIES] [CHANGE TONER]
OPC Life sensor	-	-	[CHANGE DRUM] [CHECK CARTRIDGE] [DRUM LIFE LOW REPLACE SOON] [DRUM LIFE OVER CHANGE SUPPLIES]
Toner Life sensor	-	-	[TONER LIFE LOW REPLACE SOON] [TONER LIFE OVER CHANGE SUPPLIES] [CHECK CARTRIDGE]
Power switch	Power Switch Board	SW56	-

Note:

See TEST FUNCTIONS - SENSOR CHECK SECTION for the sensor test.

(#815 of Service Mode test. Refer to **Test Functions** (P.136).)

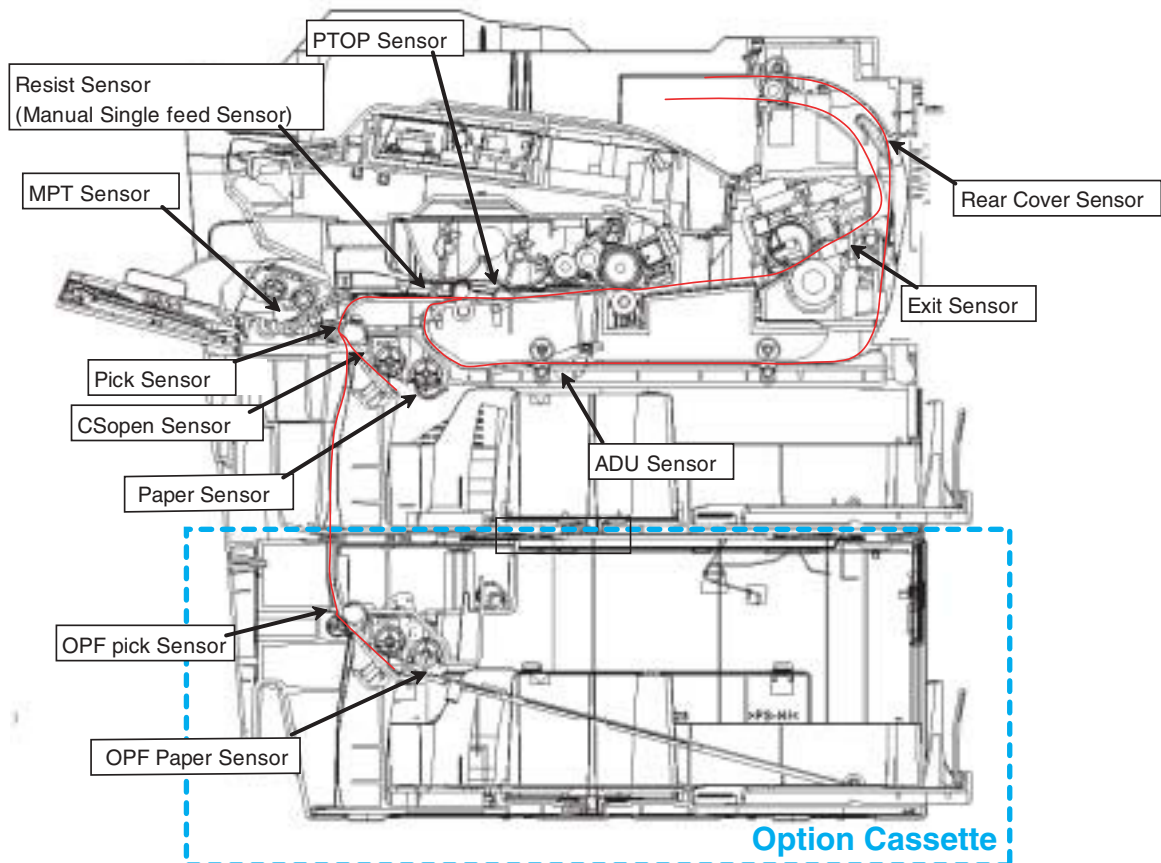

6.12.1. Pick Up Sensor

This sensor detects whether a recording paper is picked up or not.

When there is a recording paper at the position of the sensor, the input signal of IC300-AD23pin becomes low level.

When there is no recording paper at the position of the sensor, the input signal of IC300-AD23pin becomes high level.

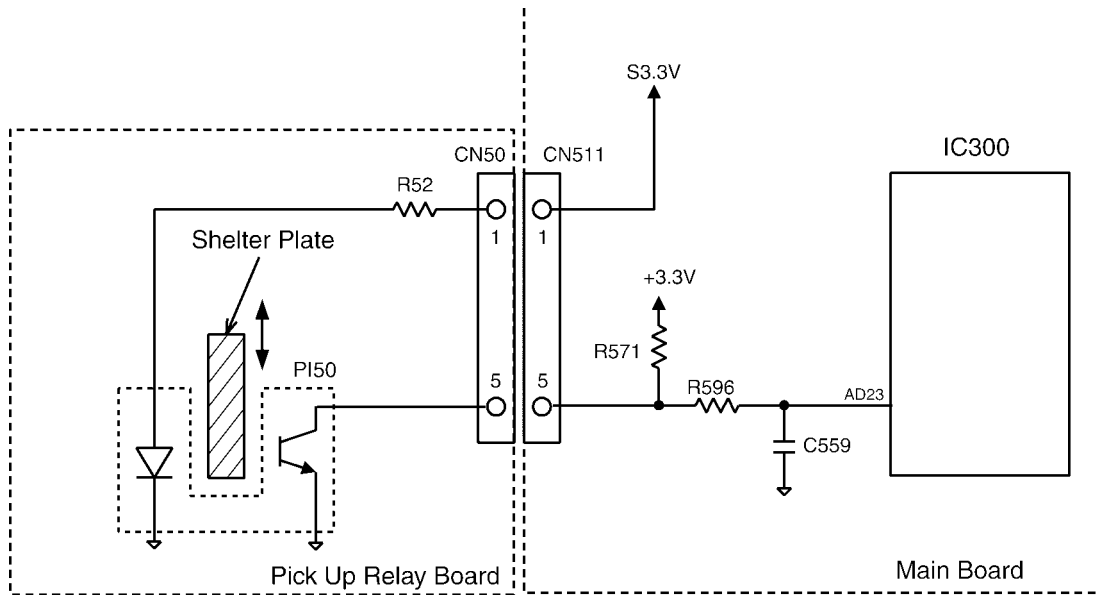

	Signal (IC300-AD23pin)
A paper exists	Low level
No papers	High level

6.12.2. Resist Sensor

This sensor detects whether a recording paper is at the sensor position.

When there is a recording paper at the position of the sensor, the input signal of IC300-AF22pin becomes high level.

When there is no recording paper at the position of the sensor, the input signal of IC300-AF22pin becomes low level.

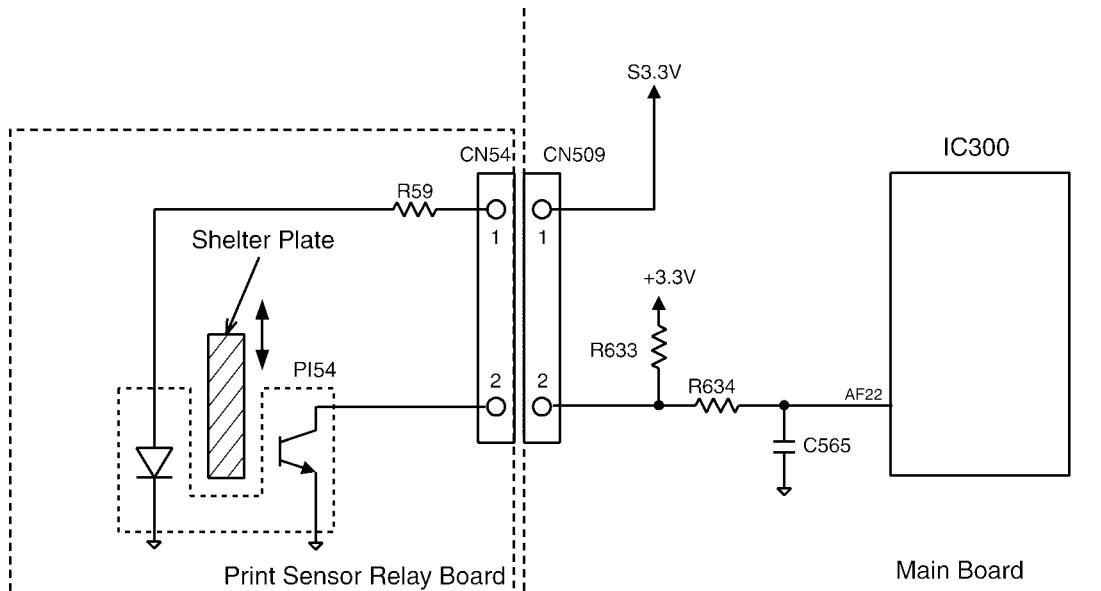

	Signal (IC300-AF22pin)
A paper exists	High level
No papers	Low level

6.12.3. PTOP Sensor (Print timing Sensor)

This sensor detects whether a recording paper is at the printing position.

When there is a recording paper at the position of the sensor, the input signal of IC300-AA25pin becomes high level.

When there is no recording paper at the position of the sensor, the input signal of IC300-AA25pin becomes low level.

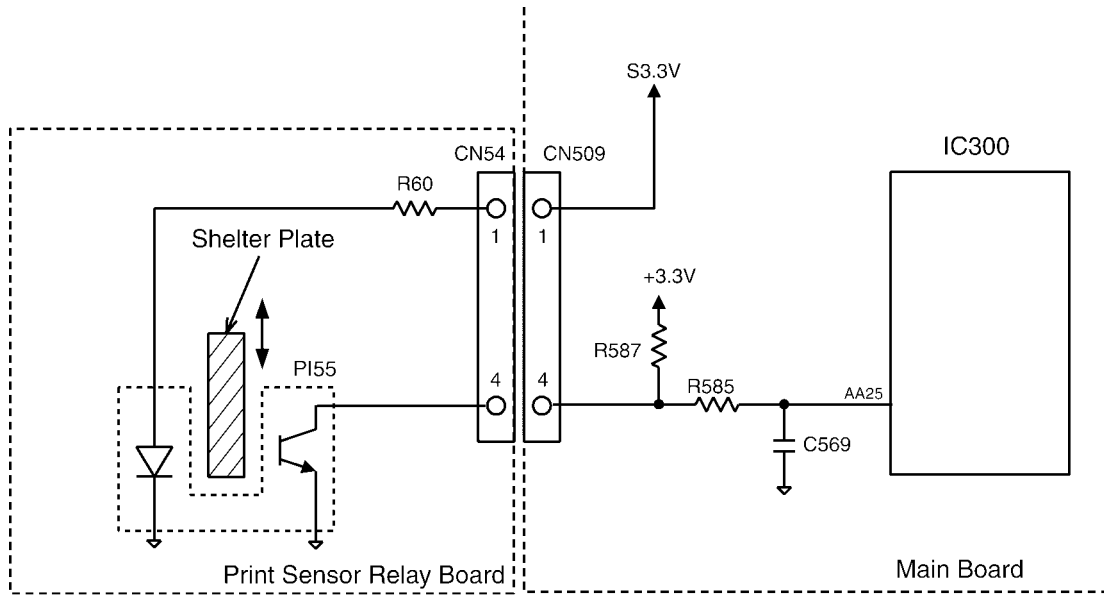

	Signal (IC300-AA25pin)
A paper exists	High level
No papers	Low level

6.12.4. ADU Sensor

This sensor detects whether a recording paper is at the sensor position.

When there is a recording paper at the position of the sensor, the input signal of IC300-Y26pin becomes high level.

When there is no recording paper at the position of the sensor, the input signal of IC300-Y26pin becomes low level.

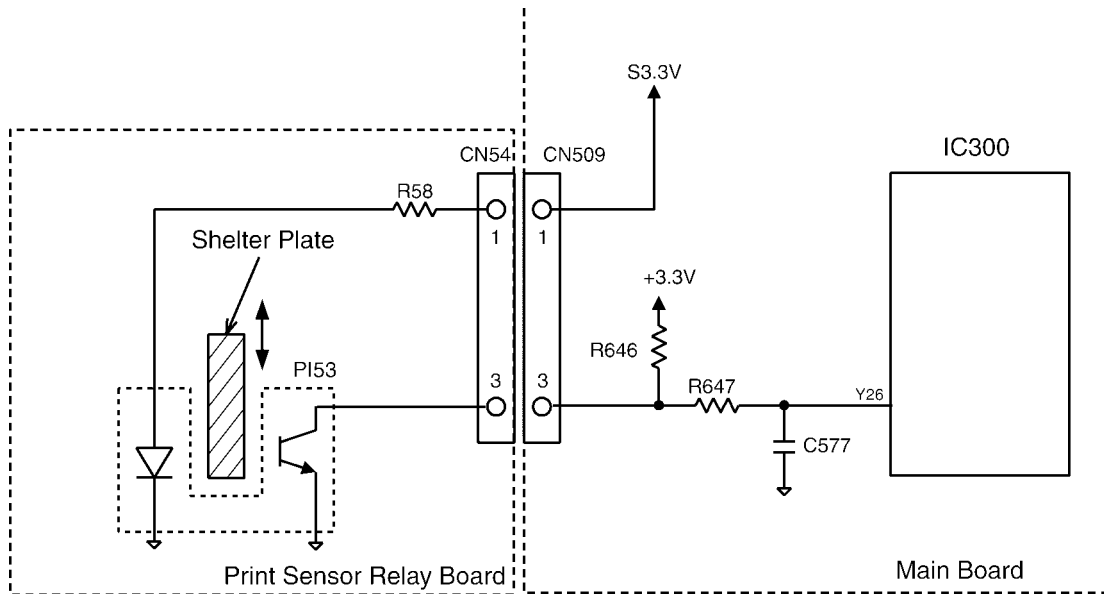

	Signal (IC300-Y26pin)
A paper exists	High level
No papers	Low level

6.12.5. Exit Sensor

This sensor detects whether a recording paper exits or not.

When there is a recording paper at the position of the sensor, the input signal of IC300-AF23pin becomes low level.

When there is no recording paper at the position of the sensor, the input signal of IC300-AF23pin becomes high level.

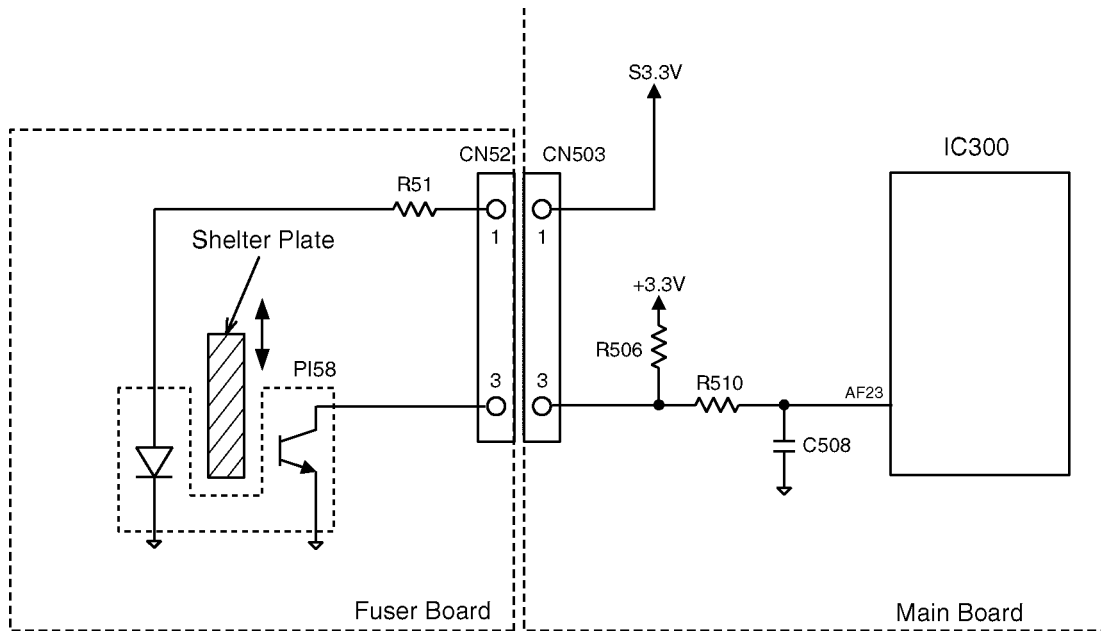

	Signal (IC300-AF23pin)
No papers	High level
A paper exists	Low level

6.12.6. Document Sensor

This sensor detects whether a document is set in ADF or not.

When a document is set in ADF, the shelter plate lets the sensor light pass.

So the photo-transistor turns on, and input signal of IC300-AC26pin becomes low level.

When a document is not set in ADF, the shelter plate closes the sensor light.

So the photo-transistor turns off, and input signal of IC300-AC26pin becomes high level.

This sensor LED is controlled by IC300-M26pin.

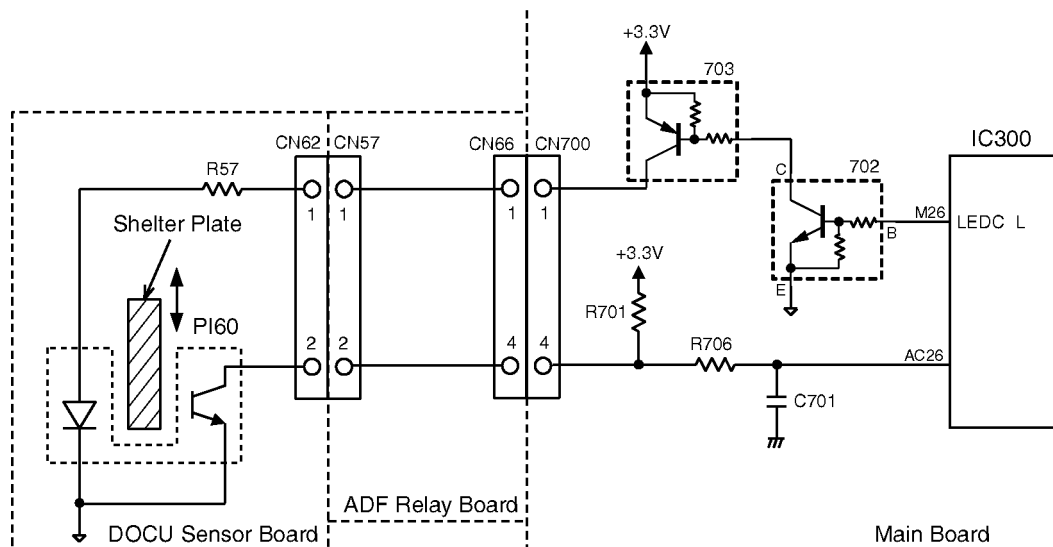

	Signal (IC300-AC26pin)
Document exists	Low level
No document	High level

LED control	Signal (IC300-M26pin)
Sleep	50% duty
Standby	High

6.12.7. Read Position Sensor

This sensor detects the front edge of the document.

When the front edge of the document is detected, the shelter plate closes the sensor light.

So the photo-transistor turns off and the input signal of IC300-AB24pin becomes high level.

When the front edge of the document is not detected, the shelter plate lets the sensor light pass.

So the photo-transistor turns on and the input signal of IC300-AB24pin becomes low level.

This sensor LED is controlled by IC300-M26pin.

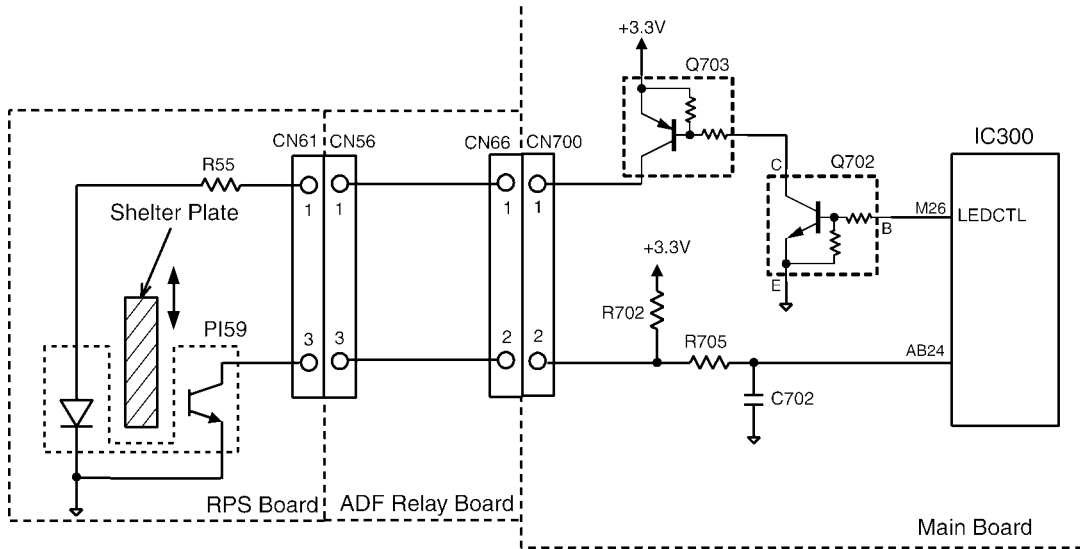

	Signal (IC300-AB24pin)
A document exists	High level
No document	Low level

LED control	Signal (IC300-M26pin)
Sleep	50% duty
Standby	High

6.12.8. RADF JAM Sensor (Only for KX-MB25** and DP-MB***)

This sensor detects the front edge of the document.

When the front edge of the document is detected, the shelter plate closes the sensor light. So the photo-transistor turns off and the input signal of IC300-AB25pin becomes high level.

When the front edge of the document is not detected, the shelter plate lets the sensor light pass. So the photo-transistor turns on and the input signal of IC300-AB25pin becomes low level.

This sensor LED is controlled by IC300-M26pin.

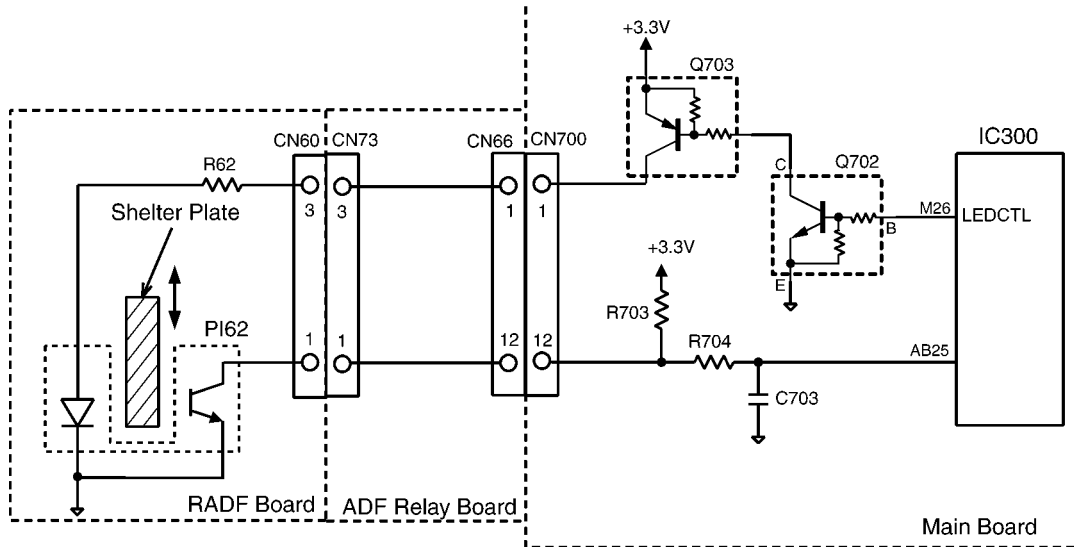

	Signal (IC300-AB25pin)
A document exists	High level
No document	Low level

LED control	Signal (IC300-M26pin)
Sleep	50% duty
Standby	High

6.12.9. MPT Sensor

This sensor detects whether a recording paper is set in MPT or not.

When there is a recording paper at the position of the sensor, the input signal of IC300-AF24pin becomes low level.

When there is no recording paper at the position of the sensor, the input signal of IC300-AF24pin becomes high level.

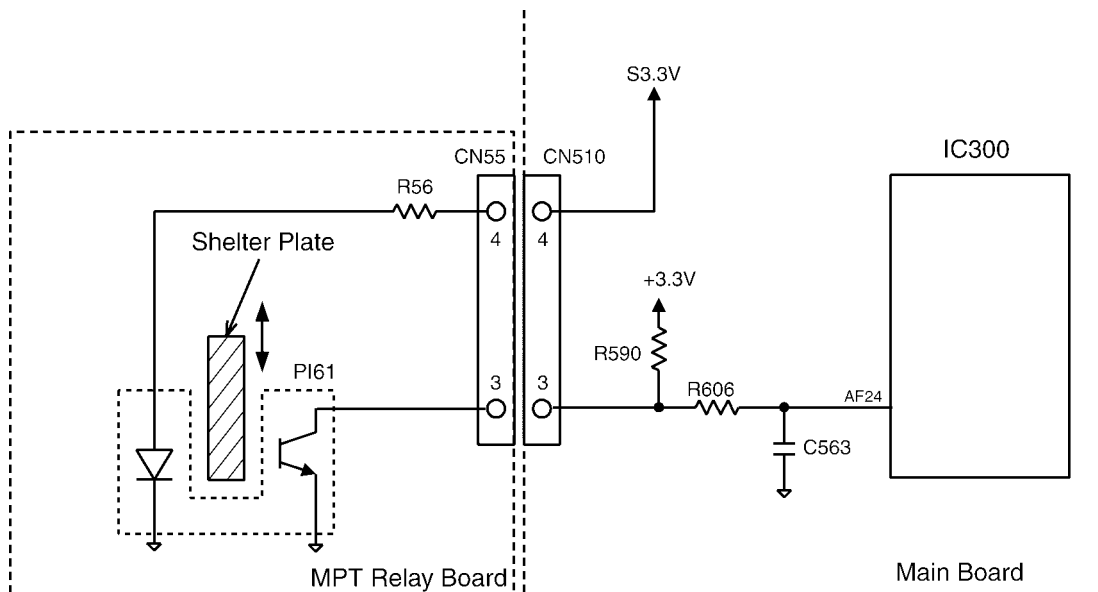

	Signal (IC300-AF24pin)
A paper exists	High level
No papers	Low level

6.12.10. Paper Sensor

This sensor detects whether a recording paper is in cassette or not.

When there is a recording paper the input signal of IC300-AD26pin becomes high level.

When there is no recording paper in cassette, the input signal of IC300-AD26pin becomes low level.

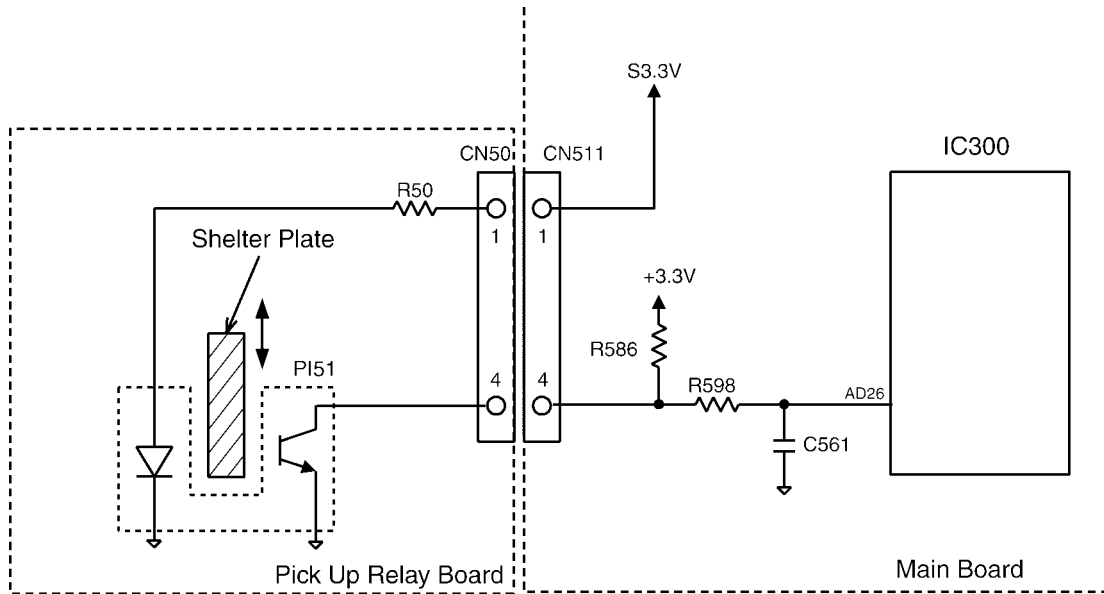

	Signal (IC300-AD26pin)
A paper exists	High level
No papers	Low level

6.12.11. CS open Sensor

This sensor detects whether the cassette is drawn out or not.

When there is the cassette, the input signal of IC300-AC24pin becomes high level.

When there is no cassette, the input signal of IC300-AC24pin becomes low level.

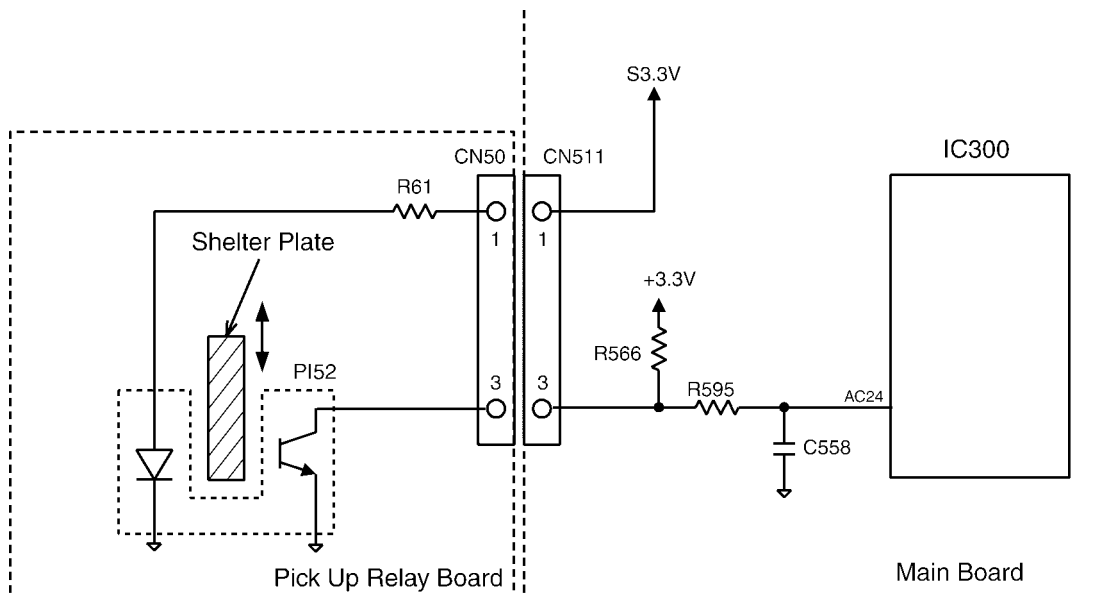

	Signal (IC300-AC24pin)
The cassette exists	High level
No Cassette	Low level

6.12.12. Rear door Sensor

The sensor detects whether the rear cover is open or close.

When the rear cover is close, the input signal of IC300-P26pin becomes high level.

When the rear cover is open, the input signal of IC300-P26pin becomes low level.

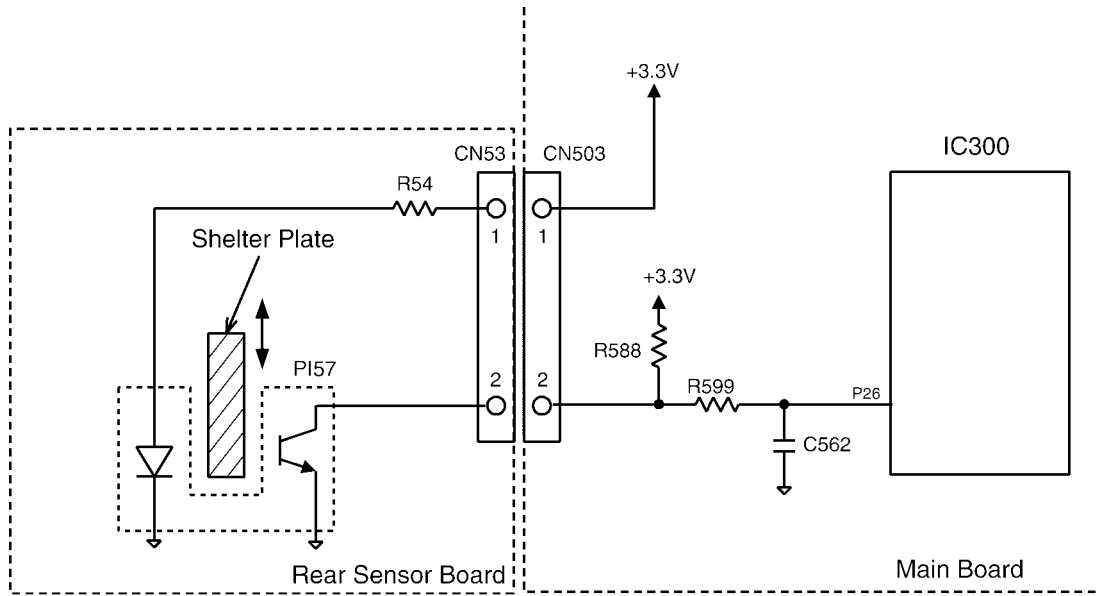

	Signal (IC300-P26pin)
Cover close	High
Cover open	Low

6.12.13. Interlock switch

The switches detect whether the front cover is open or close.

When the front cover is close, the both switches turn ON, and the input signal of IC300-W25pin becomes Low level.

When the front cover is open, the both switches turn OFF, and the input signal of IC300-W25pin becomes High level.

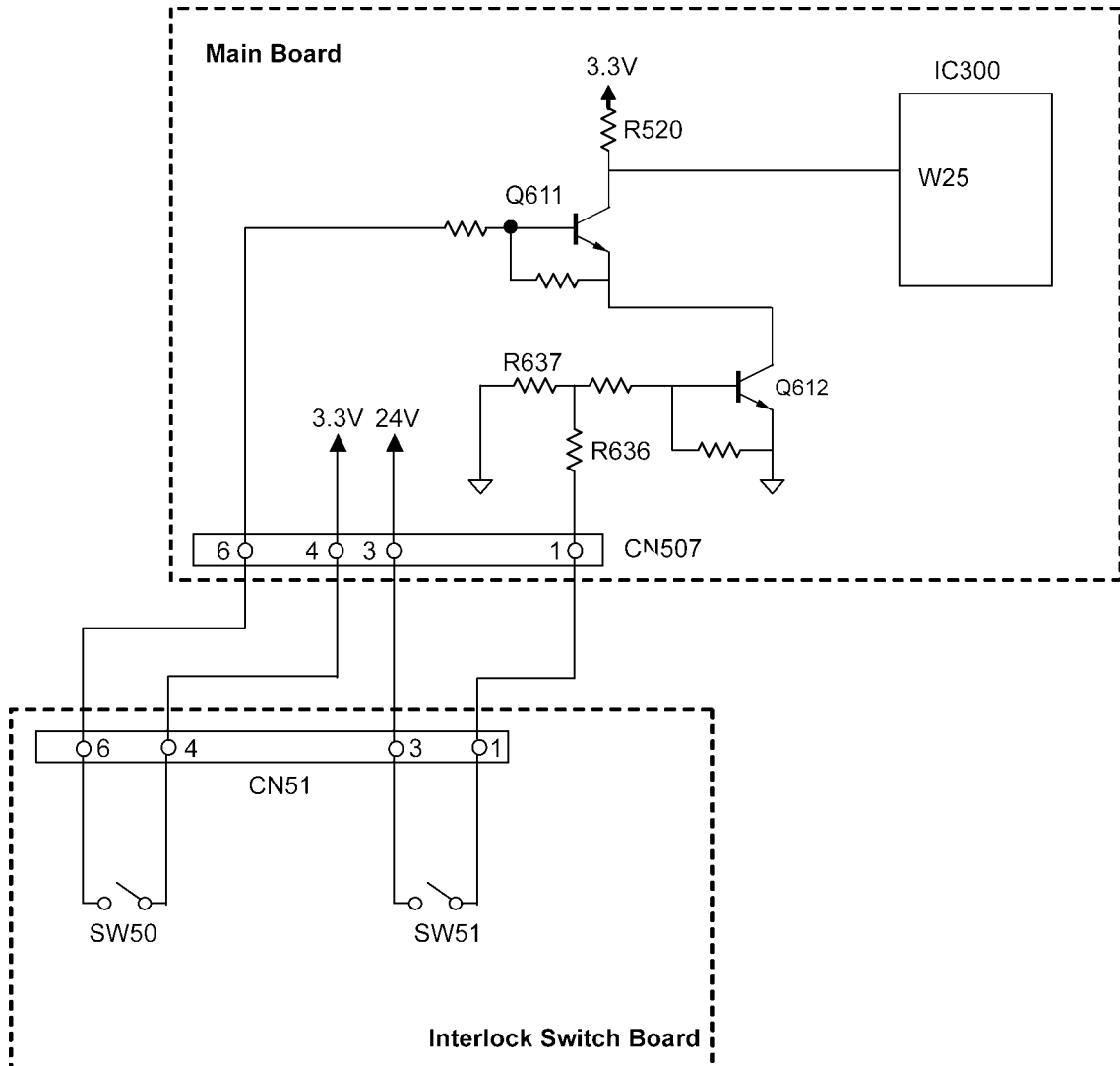

Front Cover	Switch	Signal (IC300-W25pin)
Open	OFF	High level
Close	ON	Low level

6.12.14. Toner Sensor

This sensor detects whether toner is present.

If the time of IC300-AC25pin's Low level is under 0.45s, there is enough toner in Drum cartridge, if not, toner is near empty.

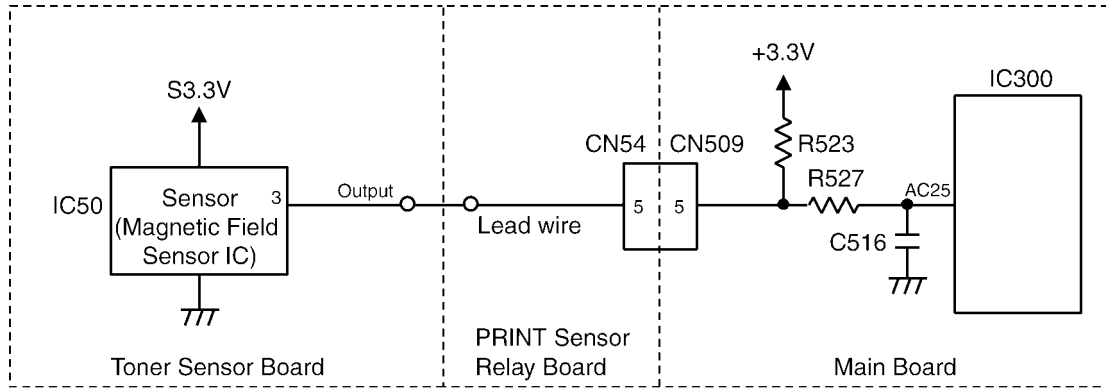

1. Toner Full

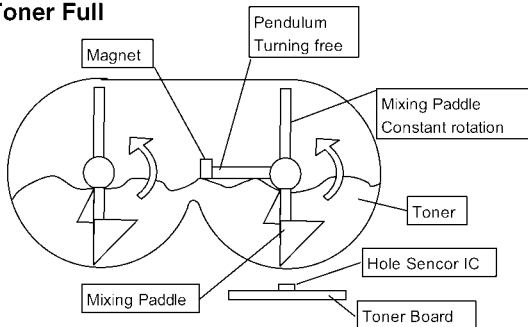

Sensor Signal

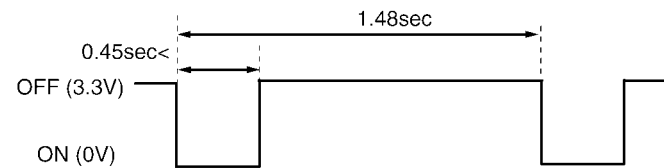

2. Toner Low

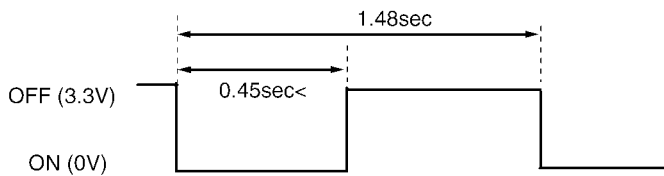
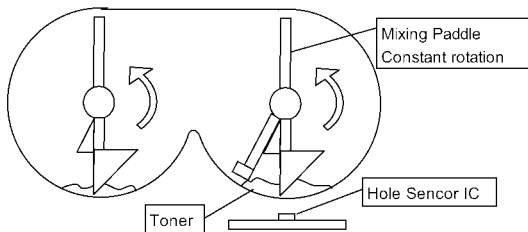

3. In case the Mixing Paddle does not rotate

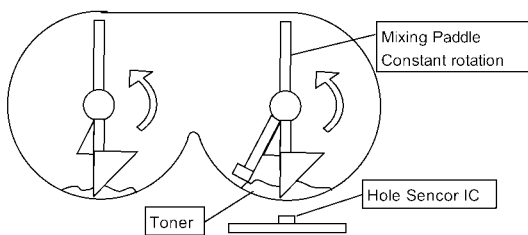

3.1

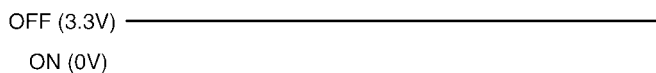

3.2

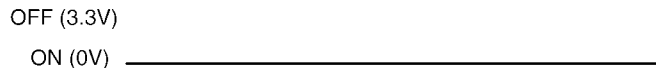

Toner Sensor

The rest of toner is detected by the move speed of the magnet put on the pendulum of Mixing Paddle. The pendulum is pushed up by the Mixing Paddle, then it falls down by its own weight. The rotation speed of paddle is set slower than the one of pendulum which falls down by its own weight. When the toner is still left, the pendulum falls and stops on the toner, then pushed by the paddle, it starts to rotate. When no toner is left, the pendulum falls to the bottom. Consequently the contact time between the magnet and Magnetic Field sensor IC becomes short when toner is left and long with no toner.

State	Display	Signal (IC300-AC25pin)
Toner full	-	Low level<0.45s
Near Empty Toner	TONER LOW	Low level>0.45s
Mixing Paddle does not rotate	CHANGE TONER	High or Low level fix

6.12.15. OPC Life Sensor Circuit

1. General

This circuit detects whether the OPC is brand-new or secondhand.

And if Drum cartridge is detected as brand-new, after predetermined printing, Fuse, which is installed inside of the OPC is cut. After cutting the fuse, the OPC is judged as secondhand, and OPC life counting starts.

This circuit consists of Fuse cut block and OPC type detection block.

2. Circuit diagram

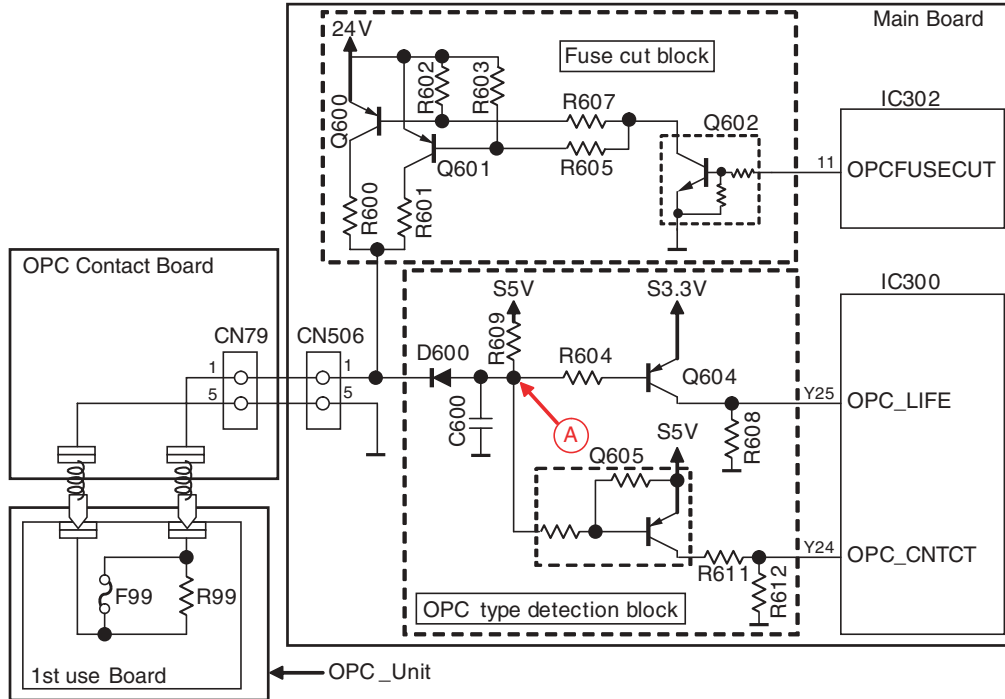

3. Circuit Explanation of Fuse cut block

When IC300_pinK26 is "H", Q600, Q601 and Q602 are turned on. Then current flows F99 through R600/R601. Consequently Fuse is cut within 1 second.

R600 and R601 are supplied to protect Q600 and Q601 from the fuse cut current.

4. Circuit Explanation of OPC type detection block

This block detects whether OPC is brand-new or secondhand.

And also detect if the contact of the terminal is normal or abnormal (contact error).

(1) In case of Brand-new Drum

Since Fuse is not open, resistance between the fuse is approx. 4ohm.

So the voltage level of point A in the above circuit diagram is less than 1V.

As the result, both Q604 and Q605 are turned on.

(2) In case of secondhand OPC

When Fuse is open, resistance between the fuse is determined by the resistance of R99 (220ohm).

Since the resistance of R609 is 120ohm, the voltage level of point A in the above circuit diagram is approx. 3.5V.

Consequently Q605 is turned on and Q604 is turned off.

(3) In case of contact error of the terminal

Since both F99 and R99 are open condition, resistance between the fuse is infinite.

So the voltage level of point A in the above circuit diagram is approx. 5V.

Then both Q604 and Q605 are turned off.

According to the above transistor condition, the logic level of IC300_pinY24 and Y25 are changed as below table.

Thus by checking these 2 signal levels, drum cartridge condition can be detected.

OPC_CNTCT (IC300_pinY24)	OPC_LIFE (IC300_pinY25)	OPC status
L	L	contact error
H	L	Secondhand
L	H	(Not used)
H	H	Brand-new

6.12.16. Toner Life Sensor Circuit

1. General

This circuit detects whether the Toner is brand-new or secondhand.

And if Toner is detected as brand-new, after predetermined printing, Fuse, which is installed inside of the Toner is cut.

After cutting the fuse, the Toner is judged as secondhand, and Toner life counting starts.

This circuit consists of Fuse cut block and Toner type detection block.

2. Circuit diagram

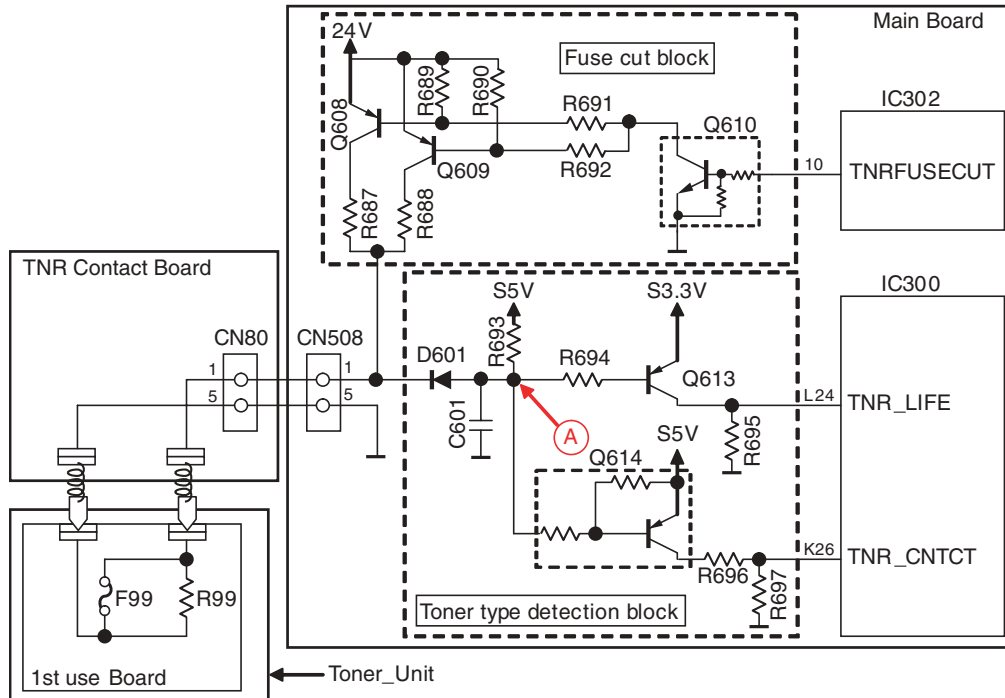

3. Circuit Explanation of Fuse cut block

When IC300_pinK26 is "H", Q608, Q609 and Q610 are turned on. Then current flows F99 through R687/R688. Consequently Fuse is cut within 1 second.

R687 and R688 are supplied to protect Q608 and Q609 from the fuse cut current.

4. Circuit Explanation of Toner type detection block

This block detects whether Toner is brand-new or secondhand.

And also detect if the contact of the terminal is normal or abnormal (contact error).

(1) In case of Brand-new Toner

Since Fuse is not open, resistance between the fuse is approx. 4ohm.

So the voltage level of point A in the above circuit diagram is less than 1V.

As the result, both Q613 and Q614 are turned on.

(2) In case of secondhand Toner

When Fuse is open, resistance between the fuse is determined by the resistance of R99 (220ohm).

Since the resistance of R693 is 120ohm, the voltage level of point A in the above circuit diagram is approx. 3.5V.

Consequently Q614 is turned on and Q613 is turned off.

(3) In case of contact error of the terminal

Since both F99 and R99 are open condition, resistance between the fuse is infinite.

So the voltage level of point A in the above circuit diagram is approx. 5V.

Then both Q613 and Q614 are turned off.

According to the above transistor condition, the logic level of IC300_pinL24 and K26 are changed as below table.

Thus by checking these 2 signal levels, drum cartridge condition can be detected.

TNR_CNTCT (IC300_pinK26)	TNR_LIFE (IC300_pinL24)	Toner status
L	L	contact error
H	L	Secondhand
L	H	(Not used)
H	H	Brand-new

6.12.17. Drum and Toner Detetion

Drum Unit Detection

Purpose

To describe drum unit detection when the drum unit is inserted.

Method

By DRUM Life SW (First use sensor) and high pressure abnormal detection signal

Flowchart

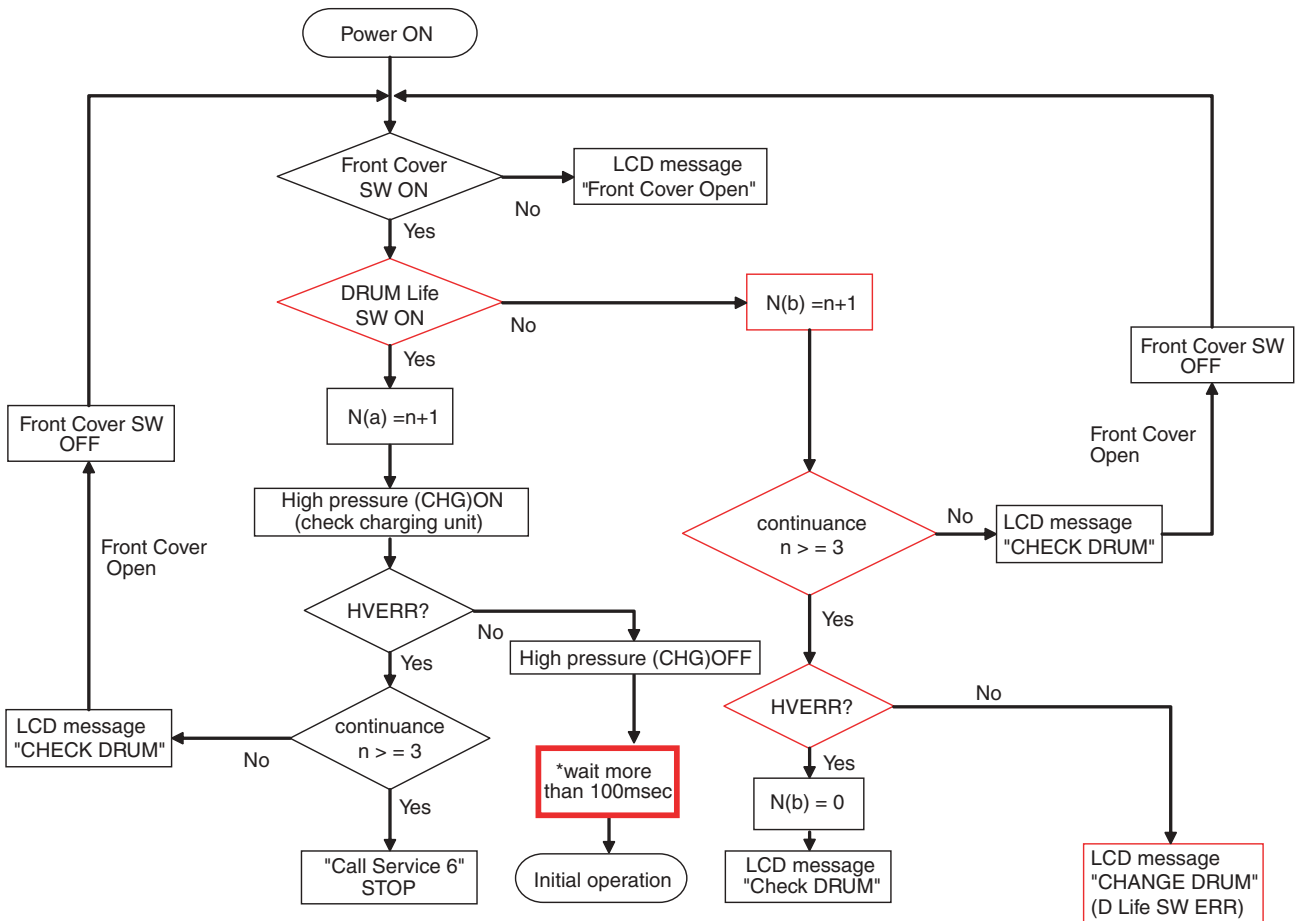

* Awaiting time from high pressure OFF to ON.
 If it turns on less than this time, high pressure ERR might occur.

Toner Life (T/L) Detection Flowchart

T/L signal = Toner Life signal

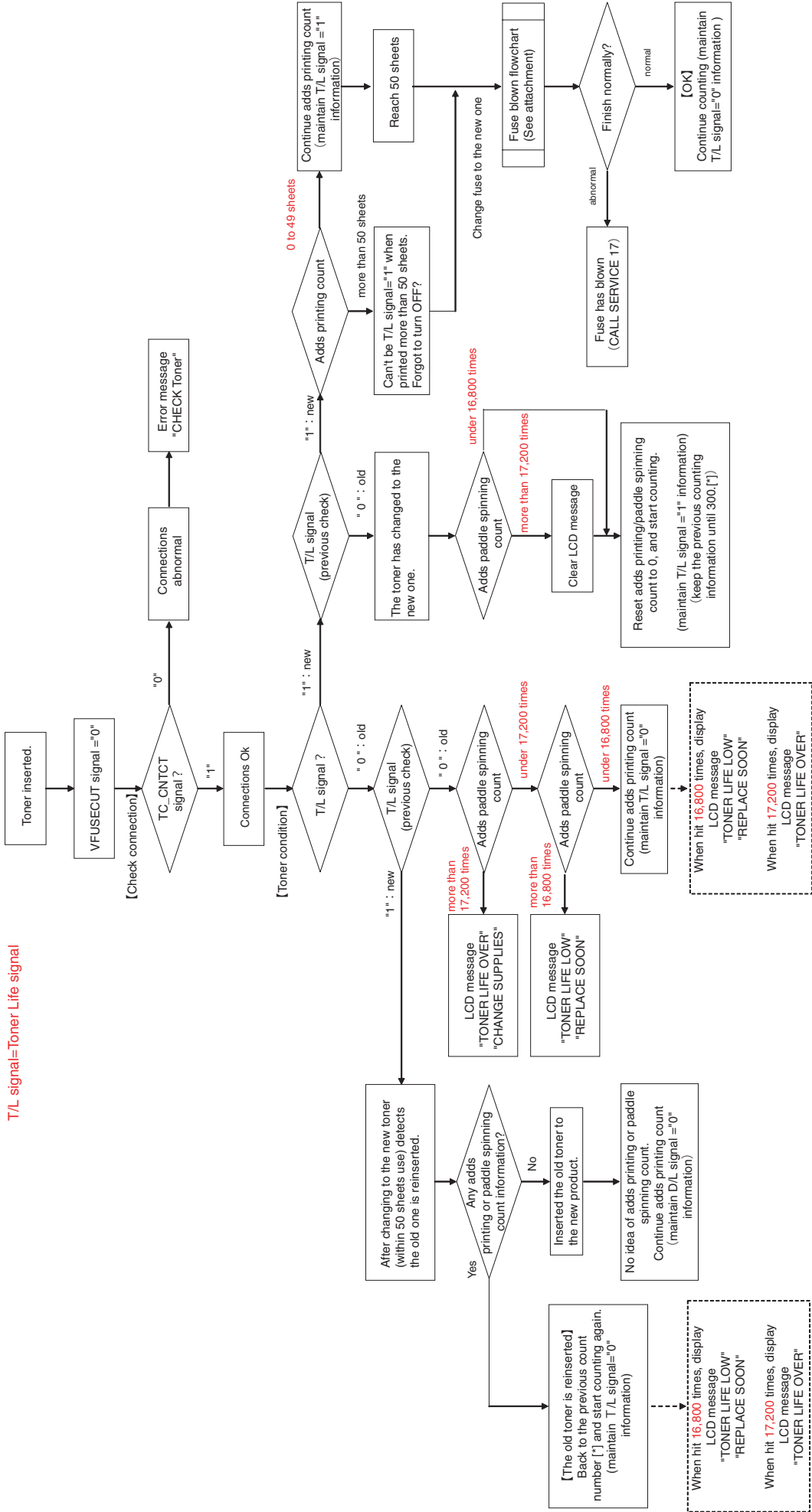

6.12.18. Power Switch

1. Circuit diagram

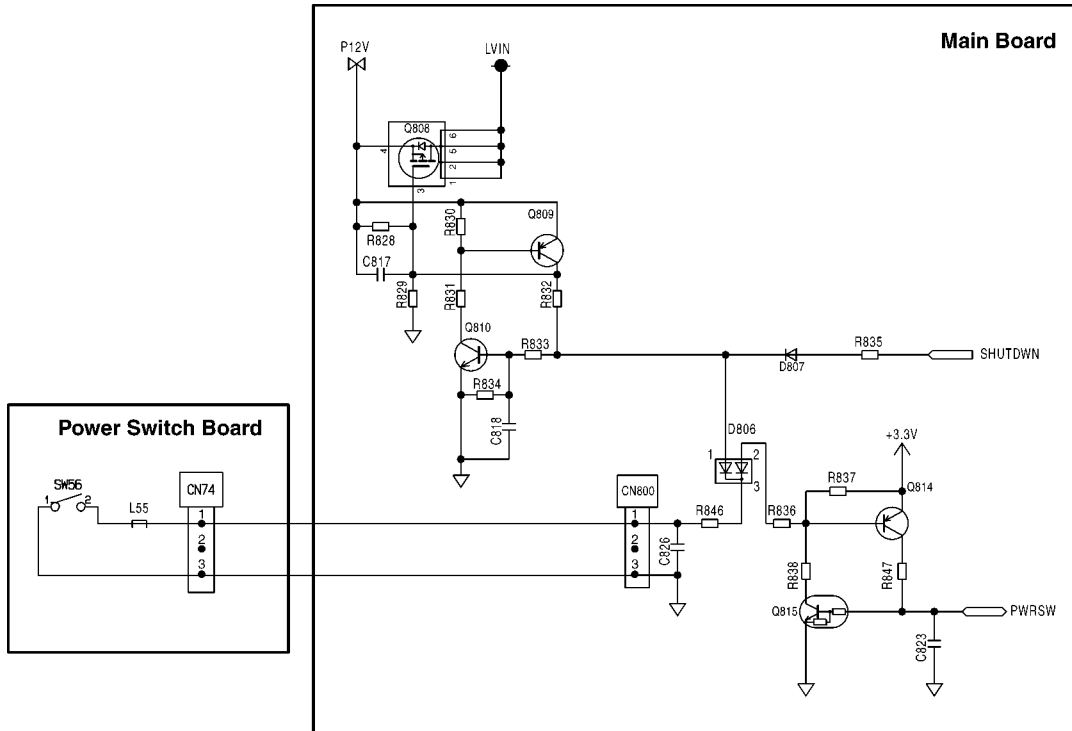

2. Circuit Explanation

2-1 During the power on

2-1-1 Power switch is pushed → Q814 ON → the logic level of PWRSW port becomes high

→ If the switch is pushed more than 3seconds, the logic level of SHUTDWN port becomes high

→ Q810 ON → Q809 ON → Q808 OFF → set becomes OFF mode.

2-1-2 Power switch is pushed → Q814 ON → the logic level of PWRSW port becomes high

→ If the switch is pushed less than 3seconds and "set" key of operation panel is pushed, the logic level of SHUTDWN port becomes high

→ Q810 ON → Q809 ON → Q808 OFF → set becomes OFF mode.

2-2 During the power OFF mode

Power switch is pushed → Q814 OFF → 809 OFF → Q808 ON → set power ON

6.13. Operation Board Section

The unit consists of a LCD (Liquid crystal display), KEYS and LEDs (light-emitting diodes). They are controlled by the Gate Array (IC1) on Operation board and IC300 on Main board.

The key matrix table is shown below.

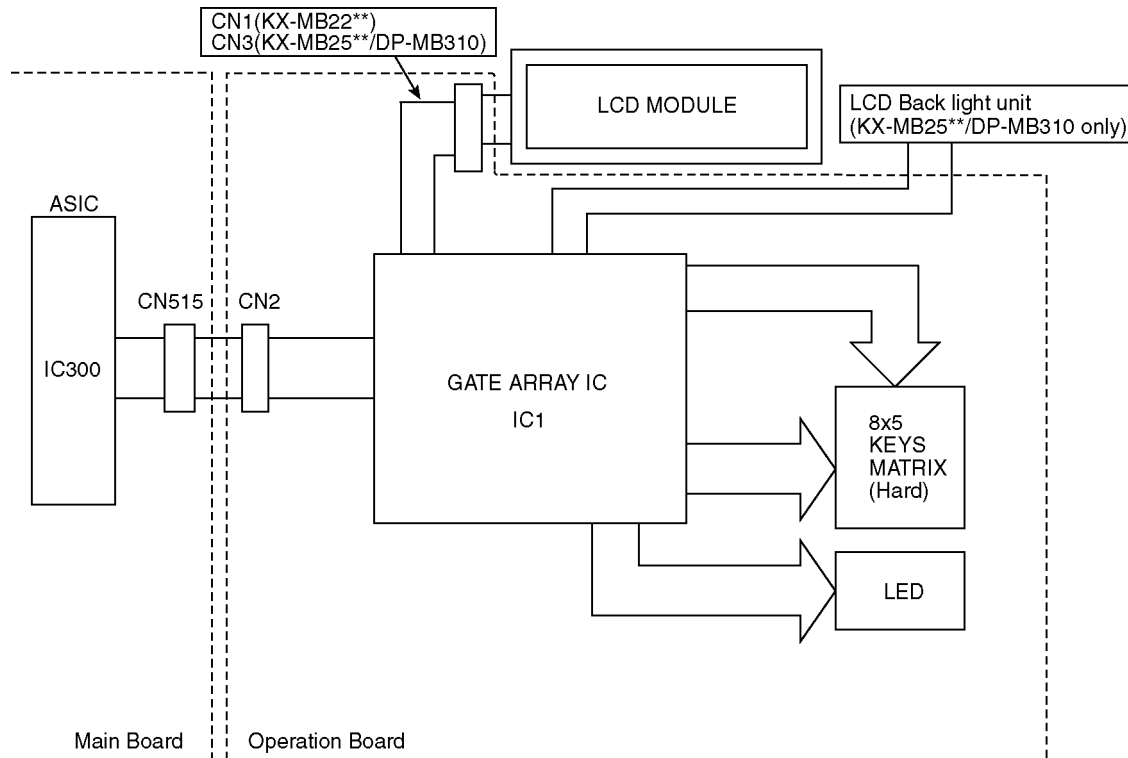

1. Key Matrix a. Hard Scan

	KIN0	KIN1	KIN2	KIN3	KIN4	KIN5	KIN6	KIN7
KSL0		↑	1	2	3	SIZE	Scan	QUALITY
KSL1	START	set	4	5	6	ZOOM	FAX (FAX model) Copy (Not FAX model)	LAYOUT
KSL2	STOP	↓	7	8	9	MONITOR	MENU	DUPLEX
KSL3	One touch Lower (DP-MB310 only)	→	*	0	#	One touch 2 (DP-MB310 only)	Copy (FAX model)	
KSL4	One touch 3 (DP-MB310 only)	←	AUTO ANSWER	Wi-Fi (WiFi model only)	ECO	One touch 1 (DP-MB310 only)		

2. LED

FAX model

- AUTO ANSWER LED ON/OFF port---XLED8 (IC1-5pin)
- FAX MODE LED ON/OFF port---XLED12 (IC1-15pin)
- COPY MODE LED ON/OFF port---XLED11 (IC1-16pin)
- SCAN MODE LED ON/OFF port---XLED13 (IC1-19pin)
- WiFi MODE LED ON/OFF port---XLED9 (IC1-6pin)
- ECO MODE LED ON/OFF port---XLED10 (IC1-9pin)
- LCD Back Light LED ON/OFF port--LED5 (IC1-41pin) (KX-MB25** ONLY)

Not FAX model

- COPY MODE LED ON/OFF port---XLED12 (IC1-15pin)
- SCAN MODE LED ON/OFF port---XLED13 (IC1-19pin)
- ECO MODE LED ON/OFF port---XLED10 (IC1-9pin)
- LCD Back Light LED ON/OFF port--LED5 (IC1-41pin) (KX-MB25** ONLY)

6.14. LCD Section

KX-MB22**

The Gate Array (IC1) works only for writing the ASCII code from the data bus (D4~D7). V0 is supplied for the LCD drive. R6 and R7 are density control resistors.

Consequently, in this unit, the timing (positive clock) is generated by the LCD interface circuitry in the gate array (IC1).

Circuit Diagram

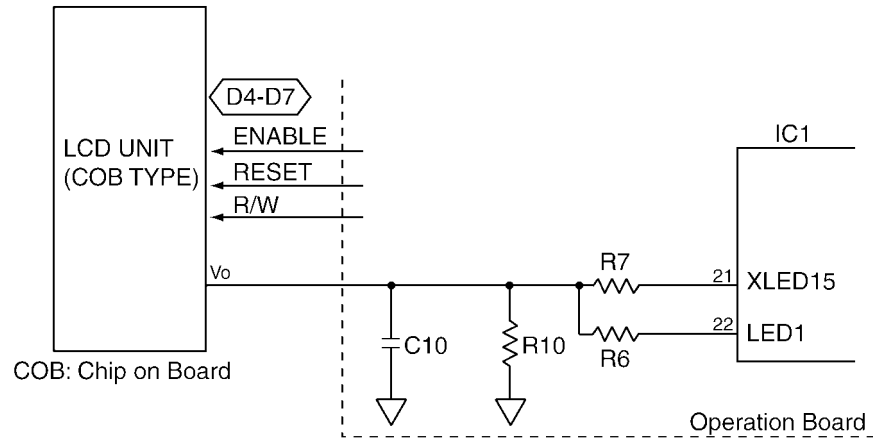

Timing Chart

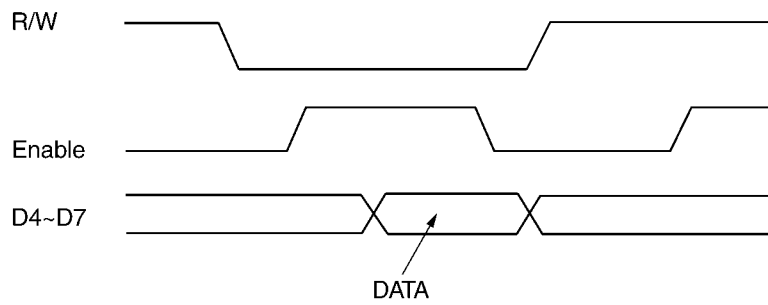

KX-MB25**

The font data is sent from SOC (Main board) through the Gate Array(IC1) by serial interface.
 The contrast is controlled by Electronic Volume. LCD reset act at Low level.(RST)

Circuit Diagram

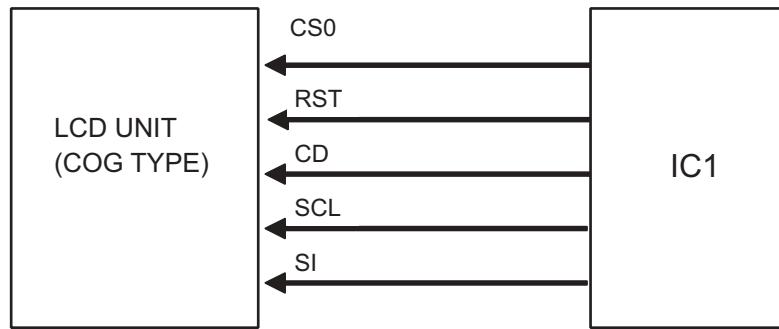

COG:Chip on Glass

Timing Chart

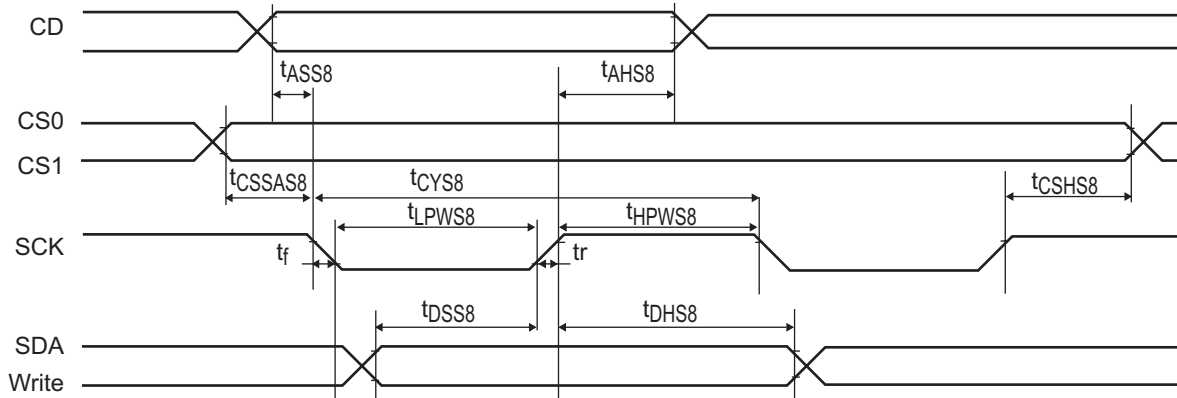

6.15. HVPS (High Voltage Power Supply) Section

6.15.1. HVPS Specification

	Charge (CHG)	Grid	Developing DC (DEV DC)	Developing AC (DEV AC)	Transfer (TRA) -	Transfer (TRA) +
Output Characteristics	Constant current	Constant voltage	Constant voltage	Constant voltage	Constant current (Variable)	Constant voltage
Nominal Output Voltage	4.35KV	475±10V	230V±15V (50~300V) PWM20% 300MΩ/220pF	330V±15Vp-p 34KHz	100MΩ (-1.48KV)	785V±100V
Nominal Output Current	200±15μA (19.4MΩ)	200μA	0.73μA	-----	-14.8μA±1μA (0μA~25μA) PWM 35%	1000MΩ (0.8μA)
Load Range	18.1MΩ~20.6MΩ	-----	100MΩ~2000MΩ	-----	33.8MΩ~284MΩ	10MΩ~1000MΩ
Constant Current Range	4.1~4.6KV	-----	-----	-----	-0.5KV ~ -4.2KV	-----

As for the developing voltage, the DC voltage and AC voltage are overlapped and output from an output terminal. There is one terminal for transcription output and + and - are switched to be output.

H.V.P.S.(High Voltage Power Supply) Circuit Diagram

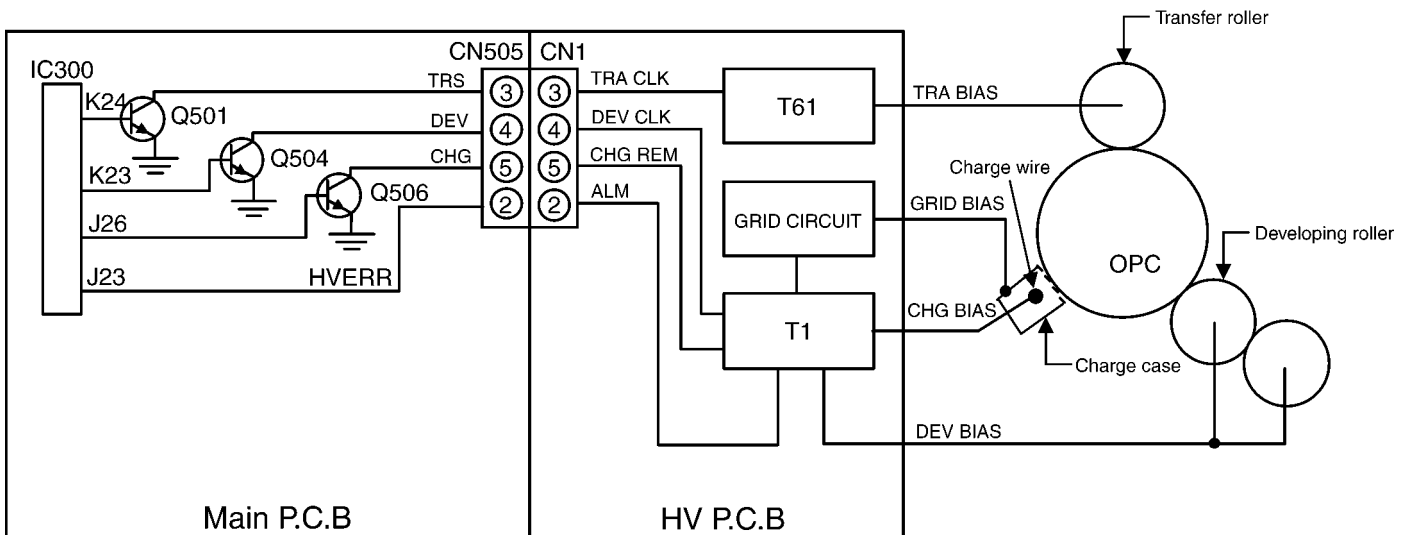

6.15.2. CHG-BIAS (Charge BIAS)/GRID/ UNIT

When IC300 turns on the transistor Q506, CHG REM becomes "L", and Charge BIAS (200μA) is output from CHG OUTPUT. GRID BIAS is generated by the current flowing in the GRID circuit via charge wire and GRID.

6.15.3. DEV DC BIAS UNIT

When CHG REM is "L", 5.425kHz PWM (Pulse Width Modulation) is input from IC300 to DEV CLK through Q504, developing voltage corresponding to the DUTY of PWM signal is output from DEV OUTPUT. Also DUTY is adjusted by the utilization of the developing unit and environmental temperature.

Transfer Current Variation by PWM Input

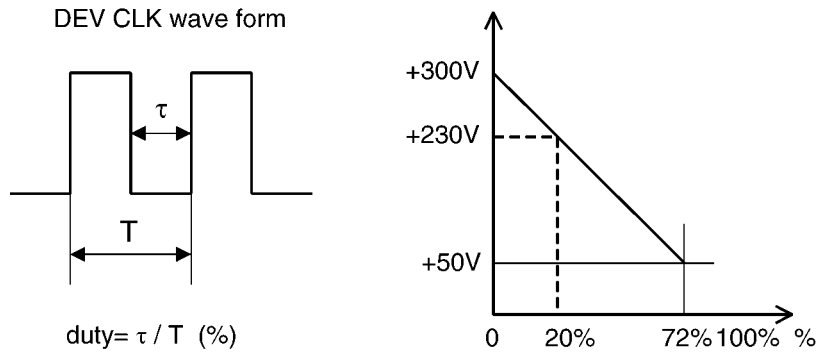

6.15.4. DEV AC BIAS UNIT

330 Vp-p 34 kHz wave of developing AC voltage is output from DEV OUTPUT. This voltage is overlapped with developing DC voltage and output as AC voltage that includes the development DC voltage.

6.15.5. TRA (+) BIAS (Transfer (+) BIAS)/TRA (-) BIAS (Transfer (-) BIAS) UNIT

When CHG REM is "L" and TRA CLK is "open", Charge BIAS (200 μ A) is output from CHG OUTPUT, and at the same time Transfer (+) BIAS (785V) is output from TRA OUTPUT. When 5.086kHz PWM (Pulse Width Modulation) signal is input to TRA CLK through transistor Q501, Transfer (-) CURRENT BIAS corresponding to PWM signal is output from TRA OUTPUT.

Transcription current variation corresponding to PWM input

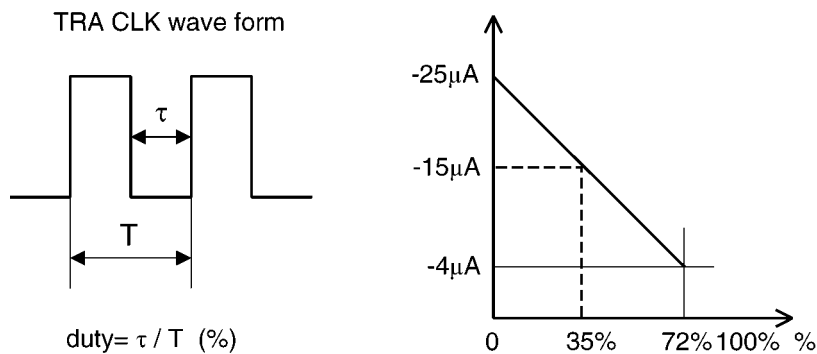

6.16. Heat Lamp Control Circuit

The temperature of the fixing part of the Fuser Unit is converted to a Voltage by THERMISTOR and input to IC300_pinC21. The heat lamp is turned on/off by the HTRCTL signal (IC300_pinAE22) through the photo triac (PC2) and the triac (SCR21). Two thermostats are provided on the AC line as the safety protection devices.

Overheat protection circuit is provided so as to prevent the Fuser unit from overheating when CPU cannot control Fuser by any problem.

IC504 compares Thermistor voltage (THRMSTR0) and predetermined voltage, which is determined by 3.3V, R581 and R584. If Thermo voltage becomes lower than this predetermined voltage (this voltage corresponds to about 240°C), output of IC504_pin7 becomes "H", then Q530 turns ON.

Once Q530 turns on, IC507_pin7 keeps "H" even after the THRMSTR0 voltage becomes bigger than the voltage of IC504_pin5. And when IC507_pin7 keeps "H", both Q500 and Q527 turn off.

As the result, once Fuser temperature exceeds 240°C (this temperature is abnormal condition), no current is supplied to Fuser lamp.

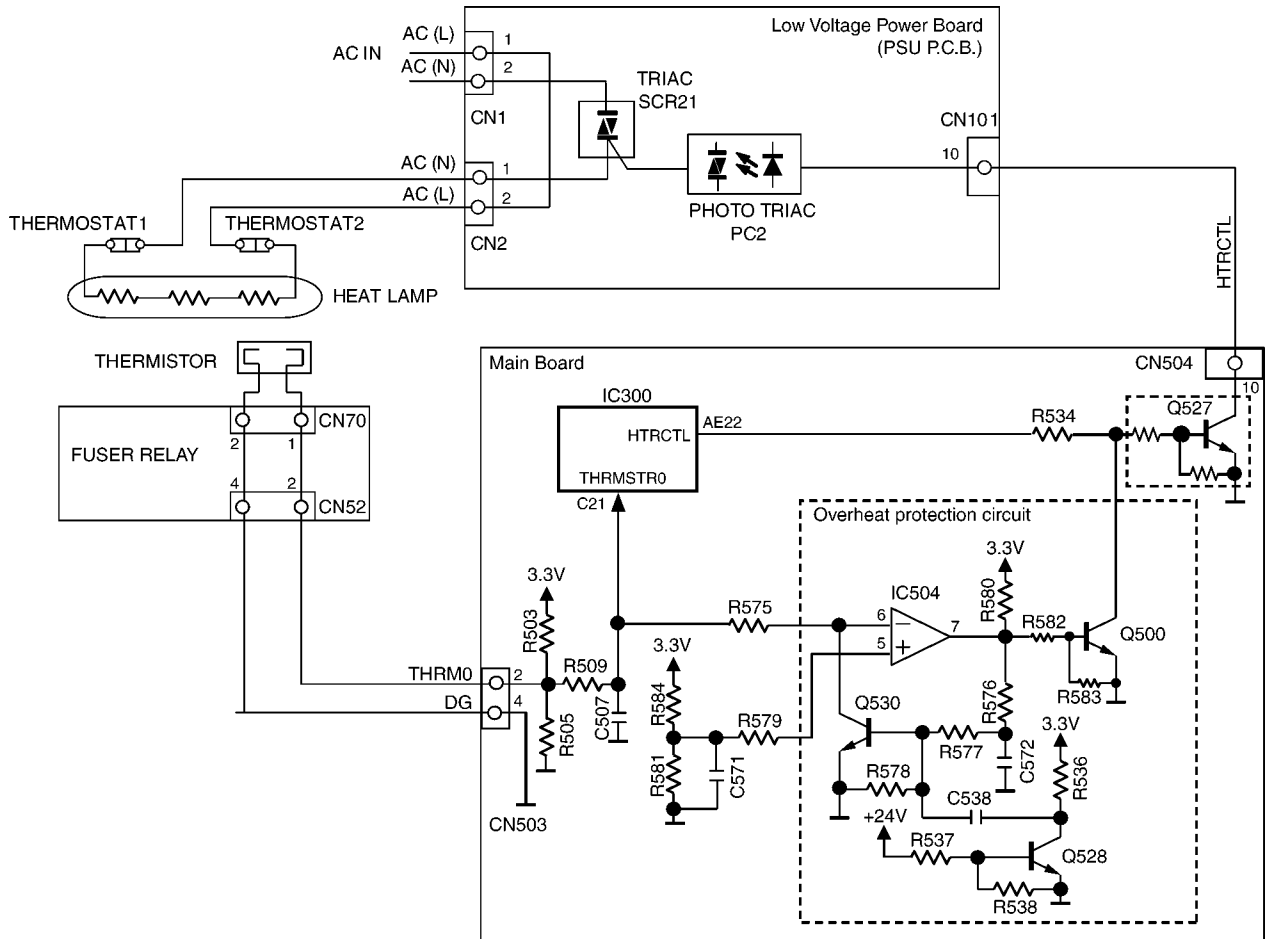

1. Heater control sequence at printing mode

- a. After receiving printing data, heater turns on.
- b. When heater temperature reaches to the Primary Stable Temperature (170°C).
- c. When heater temperature reaches to the Secondary Stable Temperature (170°C/195°C), paper feed starts.

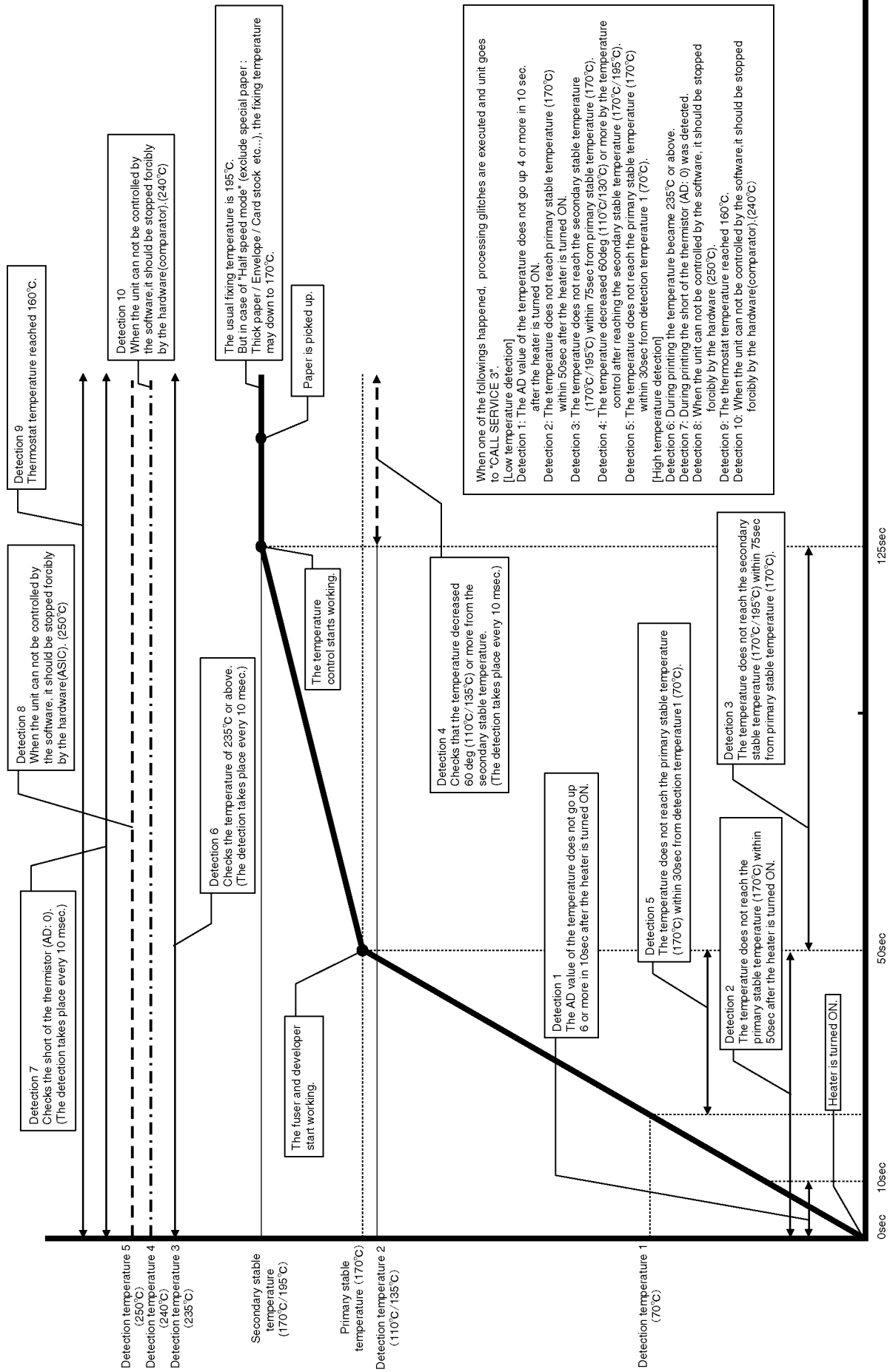

2. Safety Protection

- a. 2 thermostats are provided with the unit, and the heater circuit is shut down when their surface temperatures became over 170 °C.
- b. The heater control circuit of IC300 has the built-in function that the hardware turns off the heater control automatically if the software does not keep turning ON the heater every a fixed time.
- c. When the temperature became over 250 °C, the heater control circuit of IC300 is turned off forcedly and system reset will be executed.

3. The correspondence readings between temperature measured by fixing thermistor and HEX readings

You can read the AD value of heater temperature in service mode.

Push the keys [MENU]-[#]-[9][0][0][0]-[*]-[8][1][5].

LCD indicates as below.



These 2 digits mean the AD value(HEX) according to the table below.

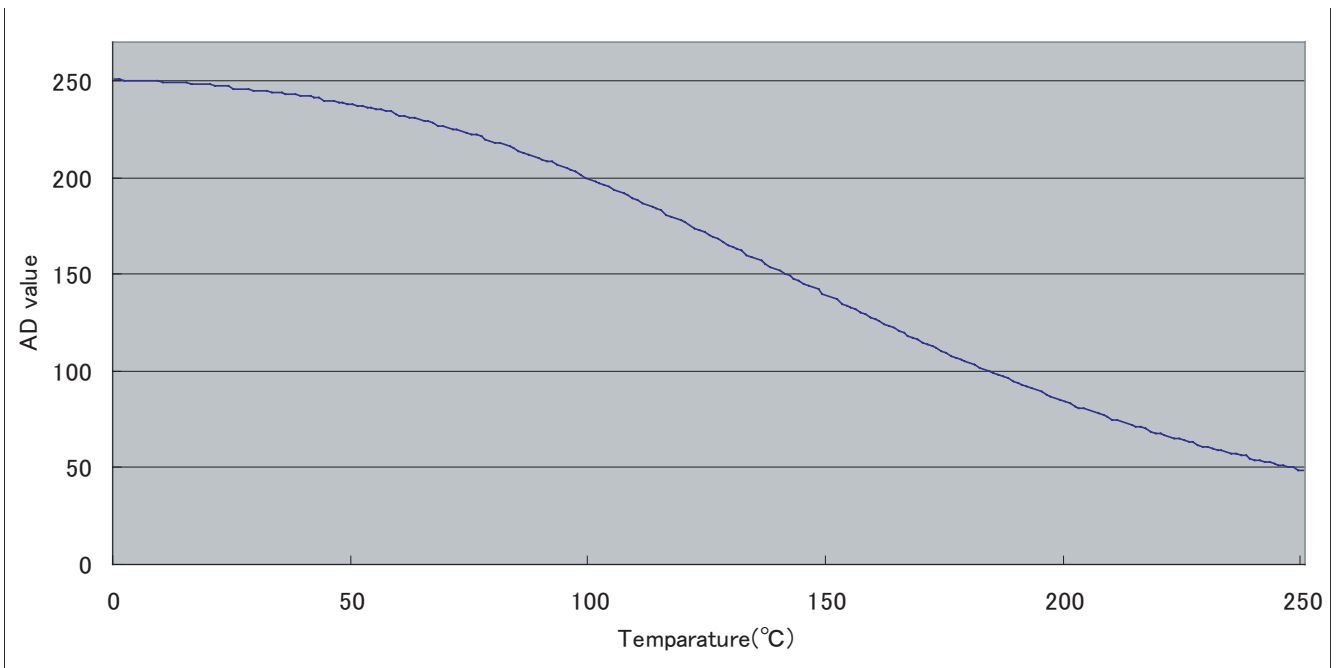

The correspondence readings between temperature measured by thermistor and HEX readings

Temperature [C°]	AD value	HEX reading	Temperature [C°]	AD value	HEX reading	Temperature [C°]	AD value	HEX reading
0	251	FB	84	215	D7	168	117	75
1	251	FB	85	214	D6	169	116	74
2	250	FA	86	213	D5	170	115	73
3	250	FA	87	212	D4	171	114	72
4	250	FA	88	211	D3	172	113	71
5	250	FA	89	210	D2	173	112	70
6	250	FA	90	209	D1	174	110	6E
7	250	FA	91	208	D0	175	109	6D
8	250	FA	92	208	D0	176	108	6C
9	250	FA	93	207	CF	177	107	6B
10	249	F9	94	206	CE	178	106	6A
11	249	F9	95	205	CD	179	105	69
12	249	F9	96	204	CC	180	104	68
13	249	F9	97	203	CB	181	103	67
14	249	F9	98	201	C9	182	102	66
15	249	F9	99	200	C8	183	101	65
16	248	F8	100	199	C7	184	100	64
17	248	F8	101	198	C6	185	99	63
18	248	F8	102	197	C5	186	98	62
19	248	F8	103	196	C4	187	97	61

Temperature [C°]	AD value	HEX reading	Temperature [C°]	AD value	HEX reading	Temperature [C°]	AD value	HEX reading
20	248	F8	104	195	C3	188	96	60
21	247	F7	105	194	C2	189	95	5F
22	247	F7	106	193	C1	190	94	5E
23	247	F7	107	192	C0	191	93	5D
24	247	F7	108	191	BF	192	92	5C
25	246	F6	109	189	BD	193	91	5B
26	246	F6	110	188	BC	194	90	5A
27	246	F6	111	187	BB	195	89	59
28	246	F6	112	186	BA	196	88	58
29	245	F5	113	185	B9	197	87	57
30	245	F5	114	184	B8	198	86	56
31	245	F5	115	183	B7	199	85	55
32	245	F5	116	181	B5	200	84	54
33	244	F4	117	180	B4	201	83	53
34	244	F4	118	179	B3	202	82	52
35	244	F4	119	178	B2	203	81	51
36	243	F3	120	177	B1	204	81	51
37	243	F3	121	175	AF	205	80	50
38	243	F3	122	174	AE	206	79	4F
39	242	F2	123	173	AD	207	78	4E
40	242	F2	124	172	AC	208	77	4D
41	242	F2	125	170	AA	209	76	4C
42	241	F1	126	169	A9	210	75	4B
43	241	F1	127	168	A8	211	75	4B
44	240	F0	128	167	A7	212	74	4A
45	240	F0	129	165	A5	213	73	49
46	240	F0	130	164	A4	214	72	48
47	239	EF	131	163	A3	215	71	47
48	239	EF	132	162	A2	216	71	47
49	238	EE	133	160	A0	217	70	46
50	238	EE	134	159	9F	218	69	45
51	237	ED	135	158	9E	219	68	44
52	237	ED	136	157	9D	220	68	44
53	236	EC	137	155	9B	221	67	43
54	236	EC	138	154	9A	222	66	42
55	235	EB	139	153	99	223	65	41
56	235	EB	140	152	98	224	65	41
57	234	EA	141	150	96	225	64	40
58	234	EA	142	149	95	226	63	3F
59	233	E9	143	148	94	227	63	3F
60	232	E8	144	147	93	228	62	3E
61	232	E8	145	145	91	229	61	3D
62	231	E7	146	144	90	230	61	3D
63	231	E7	147	143	8F	231	60	3C
64	230	E6	148	142	8E	232	59	3B
65	229	E5	149	140	8C	233	59	3B
66	229	E5	150	139	8B	234	58	3A
67	228	E4	151	138	8A	235	57	39
68	227	E3	152	137	89	236	57	39
69	227	E3	153	135	87	237	56	38
70	226	E2	154	134	86	238	56	38
71	225	E1	155	133	85	239	55	37
72	225	E1	156	132	84	240	54	36
73	224	E0	157	130	82	241	54	36
74	223	DF	158	129	81	242	53	35
75	222	DE	159	128	80	243	53	35
76	222	DE	160	127	7F	244	52	34
77	221	DD	161	126	7E	245	51	33
78	220	DC	162	124	7C	246	51	33
79	219	DB	163	123	7B	247	50	32
80	218	DA	164	122	7A	248	50	32
81	218	DA	165	121	79	249	49	31
82	217	D9	166	120	78	250	49	31
83	216	D8	167	118	76			

Note:
The value is displayed on LCD at **Test Functions (P.136) [#815]**.

4. The correspondence readings between room temperature measured by thermistor and HEX readings

You can read the AD value of room temperature in service mode.

Push the keys [MENU]-[#]-[9][0][0][0]-[*]-[8][1][5].

LCD indicates as below.



These 2 digits mean the AD value(HEX) according to the table below.

Temperature [°C]	AD value		Temperature [°C]	AD value		Temperature [°C]	AD value		Temperature [°C]	AD value		Temperature [°C]	AD value	
	DEC	HEX		DEC	HEX		DEC	HEX		DEC	HEX		DEC	HEX
-40	242	F2	-5	188	BC	30	104	68	65	45	2D	100	19	13
-39	241	F1	-4	186	BA	31	102	66	66	44	2C	101	18	12
-38	240	F0	-3	184	B8	32	100	64	67	43	2B	102	18	12
-37	239	EF	-2	182	B6	33	98	62	68	42	2A	103	17	11
-36	238	EE	-1	179	B3	34	96	60	69	41	29	104	17	11
-35	237	ED	0	177	B1	35	93	5D	70	40	28	105	17	11
-34	236	EC	1	175	AF	36	91	5B	71	39	27	106	16	10
-33	235	EB	2	172	AC	37	89	59	72	38	26	107	16	10
-32	234	EA	3	170	AA	38	87	57	73	37	25	108	15	0F
-31	233	E9	4	168	A8	39	85	55	74	36	24	109	15	0F
-30	232	E8	5	165	A5	40	83	53	75	35	23	110	15	0F
-29	230	E6	6	163	A3	41	81	51	76	34	22	111	14	0E
-28	229	E5	7	161	A1	42	79	4F	77	33	21	112	14	0E
-27	228	E4	8	158	9E	43	77	4D	78	32	20	113	14	0E
-26	226	E2	9	156	9C	44	76	4C	79	31	1F	114	13	0D
-25	225	E1	10	153	99	45	74	4A	80	31	1F	115	13	0D
-24	223	DF	11	151	97	46	72	48	81	30	1E	116	13	0D
-23	222	DE	12	148	94	47	70	46	82	29	1D	117	13	0D
-22	220	DC	13	146	92	48	69	45	83	28	1C	118	12	0C
-21	219	DB	14	143	8F	49	67	43	84	28	1C	119	12	0C
-20	217	D9	15	141	8D	50	65	41	85	27	1B	120	12	0C
-19	215	D7	16	138	8A	51	64	40	86	26	1A	121	11	0B
-18	214	D6	17	136	88	52	62	3E	87	26	1A	122	11	0B
-17	212	D4	18	133	85	53	61	3D	88	25	19	123	11	0B
-16	210	D2	19	131	83	54	59	3B	89	25	19	124	11	0B
-15	208	D0	20	128	80	55	58	3A	90	24	18	125	10	0A
-14	207	CF	21	126	7E	56	56	38	91	23	17			
-13	205	CD	22	123	7B	57	55	37	92	23	17			
-12	203	CB	23	121	79	58	54	36	93	22	16			
-11	201	C9	24	118	76	59	52	34	94	22	16			
-10	199	C7	25	116	74	60	51	33	95	21	15			
-9	197	C5	26	114	72	61	50	32	96	21	15			
-8	195	C3	27	111	6F	62	48	30	97	20	14			
-7	193	C1	28	109	6D	63	47	2F	98	20	14			
-6	190	BE	29	107	6B	64	46	2E	99	19	13			

6.17. Power Saving (Sleep) Function

The system circuit and the power supply circuit have a function which reduces power consumption. It is performed at the time of not operating condition (Sleep). The content is as follows.

When not operating for a definite period of time, it performs automatically by the following change.

1. SoC (IC300) is changed into sleep mode from normal mode.
2. PWRDWN1 and PWRDWN2 of SoC signals are changed.

PWRDWN1 changes the output voltage of the Low Voltage Power Supply board (SMPS Board).

PWRDWN2 turns on/off S3.3V output by switch circuit +24VA,+24VB and S5V are also turned on/off simultaneously with it.

*Refer to **Main Board Power Supply Section (P.103)** and **Power Supply Board Section (P.106)** for details.

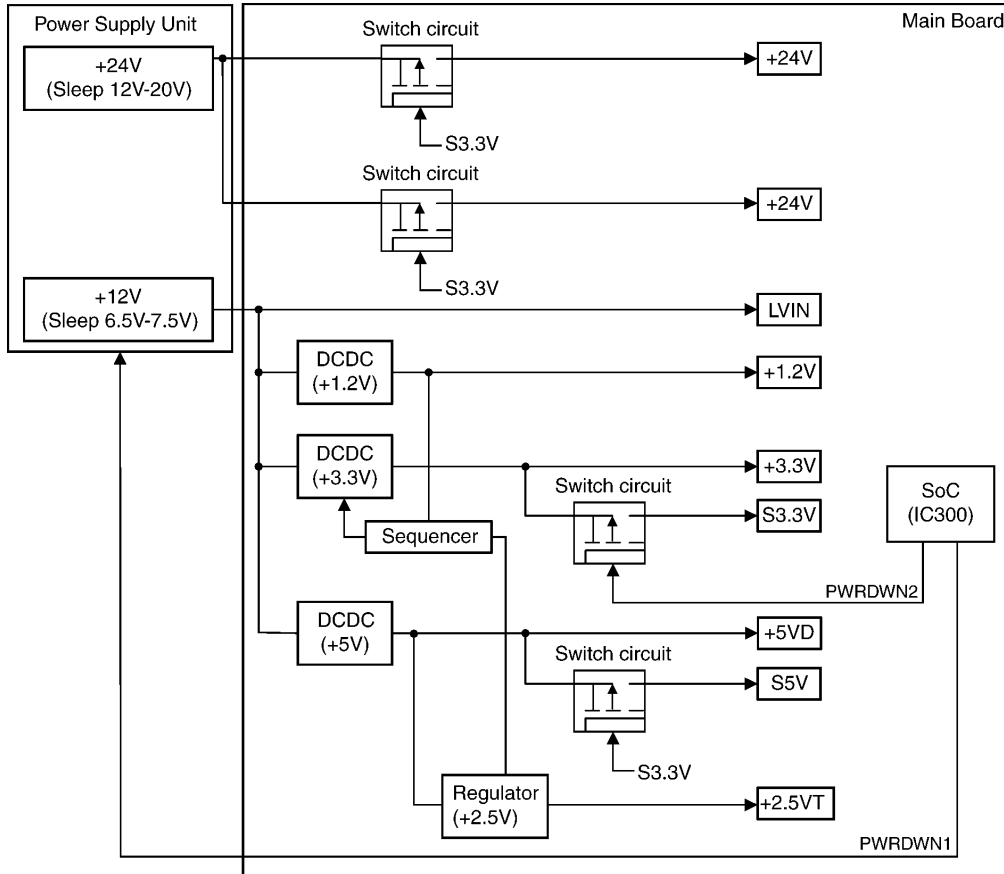

Sleep Control Flow

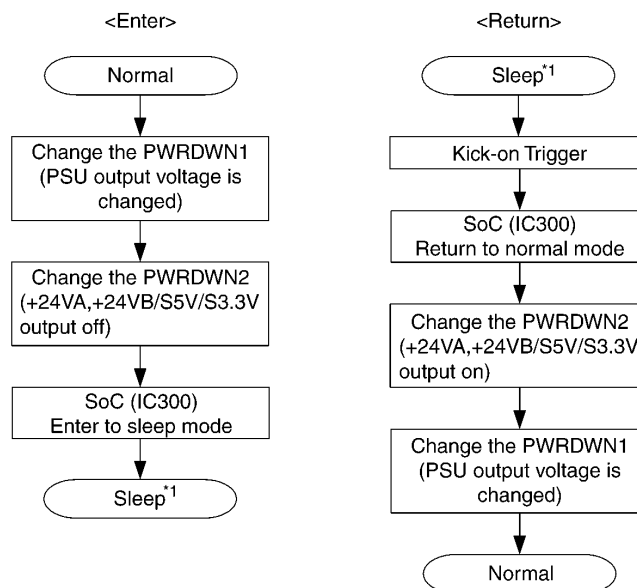

*1 "SLEEP" is indicated in LCD.

6.18. Main Board Power Supply Section

6.18.1. 3.3V and 1.2V Power Supply Descriptions

1. IC800, IC801 is Synchronous Step-Down DC/DC Converter with Auto-Skip Eco-mode to increase light load efficiency.
2. Oscillation frequency is set at approximately 700kHz (Frequency is changed at Light Load.).
3. Q803,Q804,Q805,R809,R815,C812,R816,R818,C831,R814 are Sequence circuit. (After 1.2V DC-DC converter is turned on, 3.3V(IC801)'s operation is turned on.)
4. D803, D801 are the Zener Diode for Over voltage protection.
5. Q800, R839, C800, R820 are the switch circuit which turns off a S3.3V power supply at the time of Sleep mode.

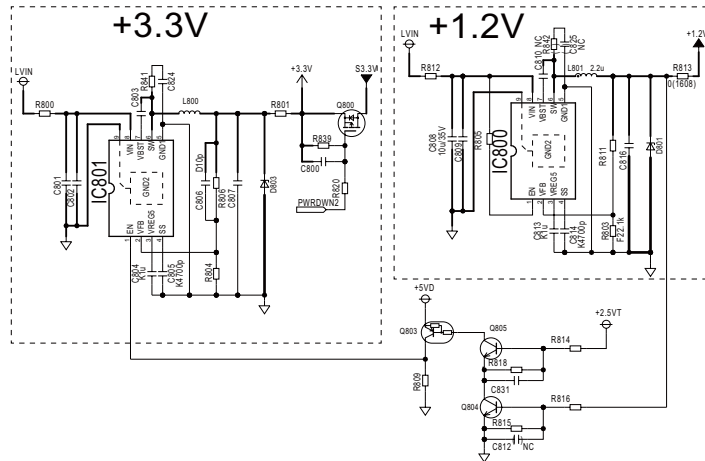

6.18.2. 5V Power Supply Descriptions

1. IC801 is PWM type DC-DC converter with an internal power MOSFET, which makes up a step-down type DC-DC converter circuit with coil of L802, Schottky diode of D804, capacitor of C819, C820 and C829.
2. D805 is the Zener Diode for Over voltage protection.
3. Q801, R823, C821, R824, Q802 are the switch circuit which turns off a 5V power supply at the time of Sleep mode.

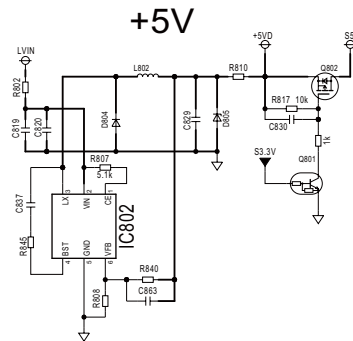

6.18.3. 24V Power Supply Descriptions

1. The switch circuit which turns off a +24V power supply at the time of Sleep mode.

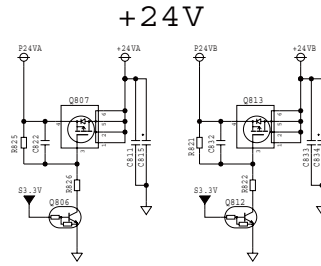

6.18.4. 2.5V Power Supply Descriptions

1. IC803 is low dropout three-terminal regulator for SPT.

+2.5V(SPT)

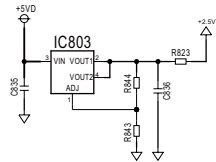

6.18.5. Main Unit Power Supply Condition

		Condition		
		Ready/Copy	Power save	Sleep
Power Supply	P24V(*1)	24V	24V	12V-20V
	+24VA	24V	24V	0V
	+24VB	24V	24V	0V
	LVIN(*2)	12V	12V	6.5V-7.5V
	+5VD	5V	5V	5V
	S5V	5V	5V	0V
	+3.3V	3.3V	3.3V	3.3V
	S3.3V	3.3V	3.3V	0V
	2.5VT	2.5V	2.5V	2.5V
+1.2V	1.2V	1.2V	1.2V	

* Low Voltage Power Supply board (SMPS Board) output

6.18.6. Main Unit Power Supply Sequence

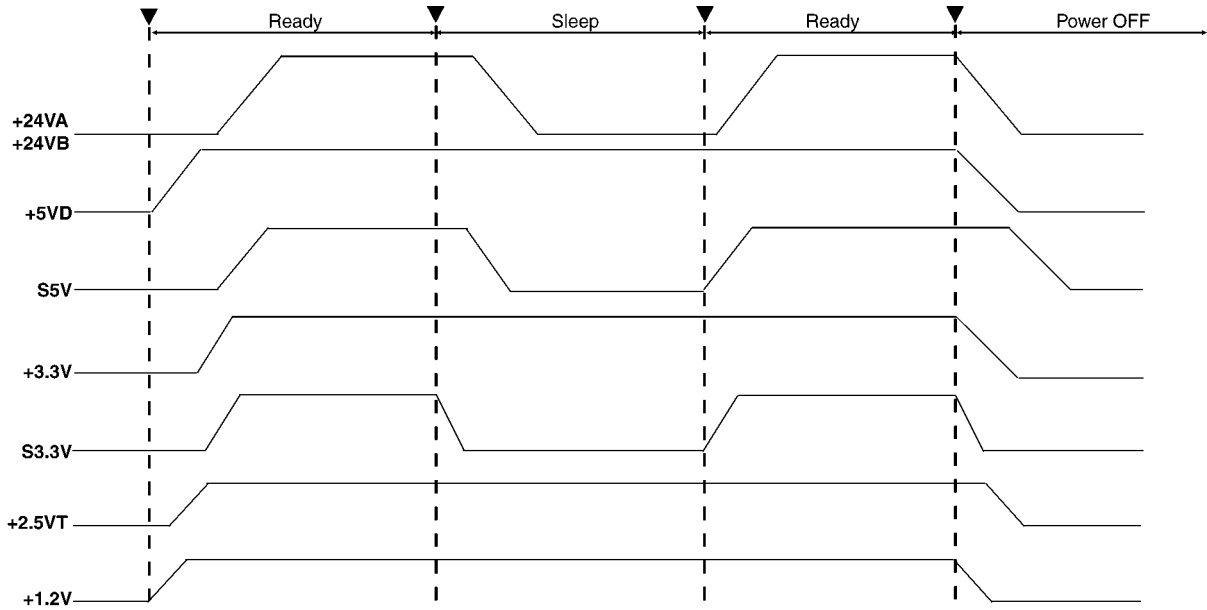

6.18.7. Wave Form

[3.3V DCDC] Ready Mode

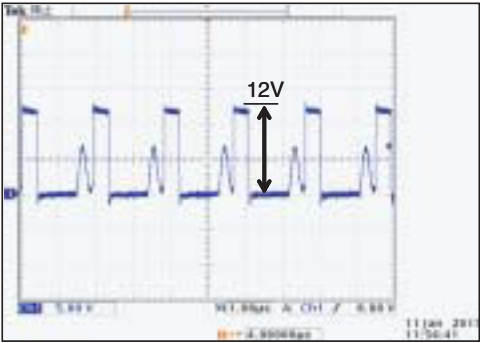

Sleep Mode

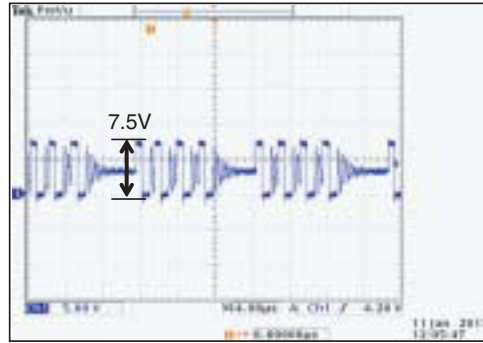

[1.2V DCDC] Ready Mode

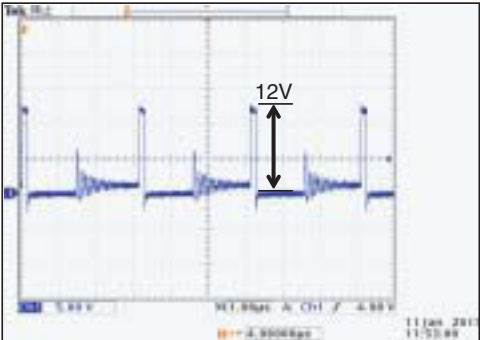

Sleep Mode

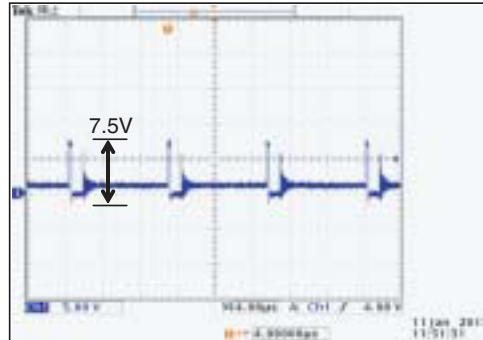

[5V DCDC] Ready Mode

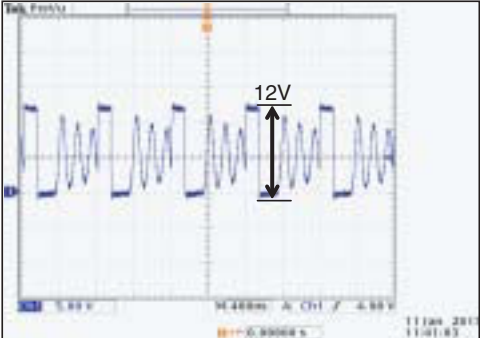

Sleep Mode

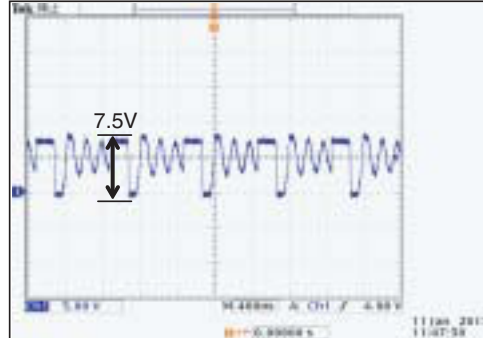

6.19. Power Supply Board Section

The power supply board circuit generates 24Vdc and 12Vdc at normal mode.

It also supplies AC voltage to the halogen heat lamp in the fuser unit.

The power supply board uses the switching regulator method, and it has a power save function.

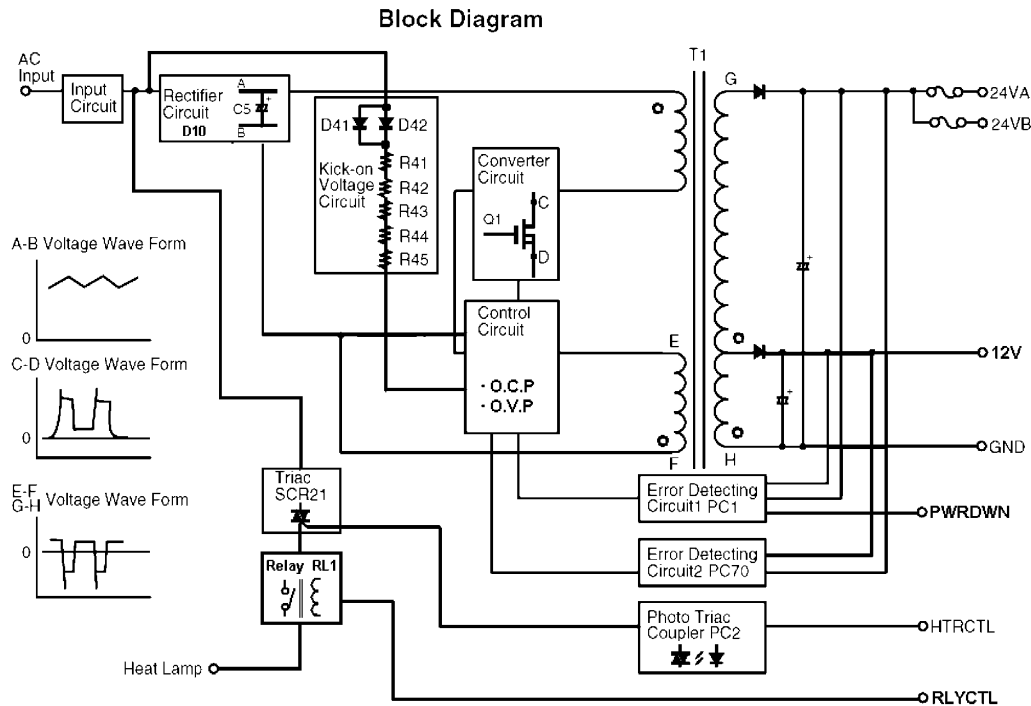

[Input Circuit]

The input current goes into the input rectifier circuit through the filter circuit.

The filter circuit decreases the noise voltage and the noise electric field strength.

[Rectifier Circuit]

The input circuit is rectified by D10 and charge C5 to make DC voltage.

Then it supplies power to the converter circuit.

[Kick-on Voltage Circuit]

Bias is applied to the Q1 gate via this circuit when the AC power is turned on and Q1 begins operating.

[Control Circuit and Error Detecting Circuit 1]

The control circuit detects the voltage that increased in an error detect circuit 1 and controls it to become the predetermined output voltage.

This is shown as follows.

When the output voltage of the 24V circuit or 12V circuit increases, the current of the photo coupler PC1 increases, the pulse width of the output control IC becomes narrower and the ON period of Q1 becomes shorter.

[Power Saving Function]

Output voltage is changed by PWRDWN signal.

Condition	PWRDWN	24Vout	12Vout
Normal	Open	24V	12V
Power Save	Low (0V)	12-20V	7V

[Over Current Protection (O.C.P)]

The highest drain current of Q1 is limited by a over current circuit. The 24V or 12V output is limited by this circuit.

[Over Voltage Protection (O.V.P)/ Error Detecting Circuit 2]

If the 24V or 12V output increases because the error detecting circuit 1 or control circuit is broken, control circuit will recognize this signal and output becomes 0V.

Dummy load method (to quickly check the power supply output).

Refer to **Low Voltage Power Supply Board (SMPS Board)Section (P.266).**

6.20. Mechanical Operation

6.20.1. Print Process

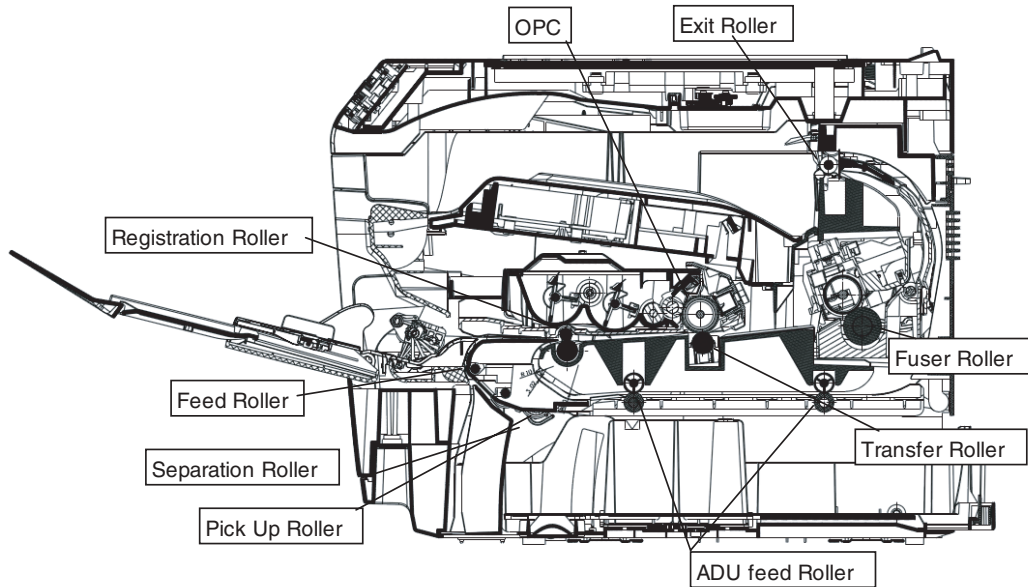

This Laser Printer creates an image on paper using a technique called laser electrophotography. The printer uses the electrographic process known as Discharged Area Development, or “write black”. In this process, a digitally modulated laser scans laterally across a rotating OPC (Organic Photo Conductor) drum that has been positively charged. Wherever the OPC drum is exposed by laser beam, the image is written and toner is transferred.

To generate a image, the OPC drum suitably rotate to the image length. During each successive pass, the laser exposes the portions of OPC drum that correspond to component of the image. Toner is attracted to the laser-exposed portions of the OPC drum.

The paper advances to the fuser, where heat and pressure permanently bond the toner to the paper. From the fuser, the paper is driven to the output tray.

6.20.2. Scanning (ADF) (Only for KX-MB22**)

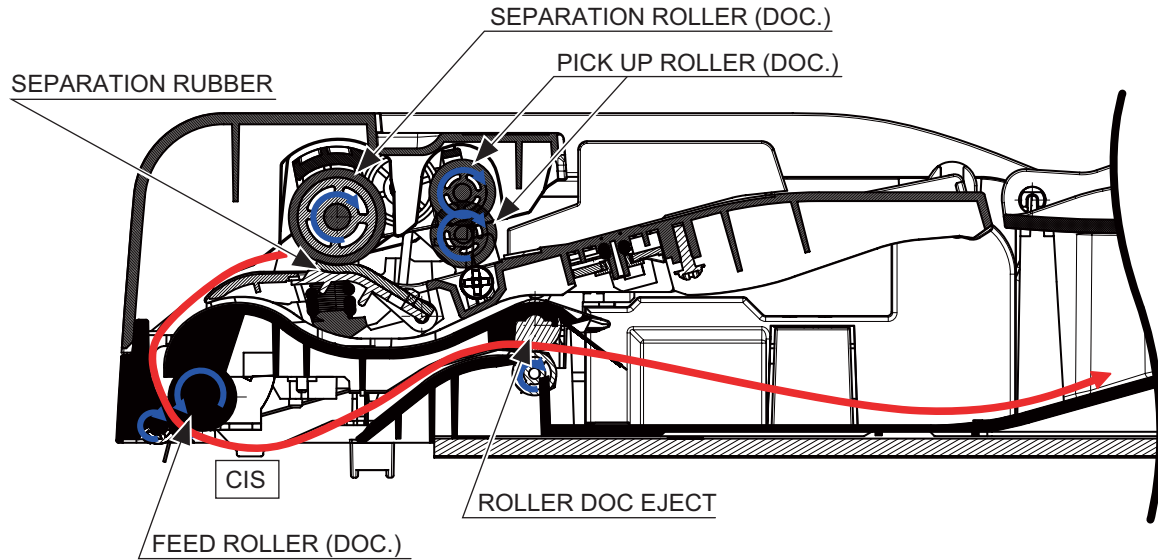

- DOCUMENT TRANSMISSION (ADF)

The frictional force between SEPARATION ROLLER (DOC.) and SEPARATION RUBBER makes PICK UP ROLLER (DOC.) move downward from standby position to pick up paper.

Pick-upped paper is separated by SEPARATION ROLLER (DOC.) and SEPARATION RUBBER (DOC.), and then fed by FEED ROLLER (DOC.).

After being read by CIS, the paper is ejected by ROLLER DOC EJECT.

- DOCUMENT TRANSMISSION (SCANNER GLASS)

CIS Module is carried by the belt timing along the shaft carriage to the reading start position.

Then it goes back to the home position reading the document through the glass.

6.20.3. Scanning (ADF) (Only for KX-MB25** and DP-MB***)

6.20.3.1. General

This Auto Document Feeder (ADF) can read double side documents as well as single side documents.

ADF motor supplies all power to rotate the rollers.

Switchback solenoid is provided to change the rotation direction of Exit Roller.

When switchback solenoid is OFF, Exit roller rotates toward the paper eject, and when ON, rotates reverse direction.

6.20.3.1.1. Single side Scanning

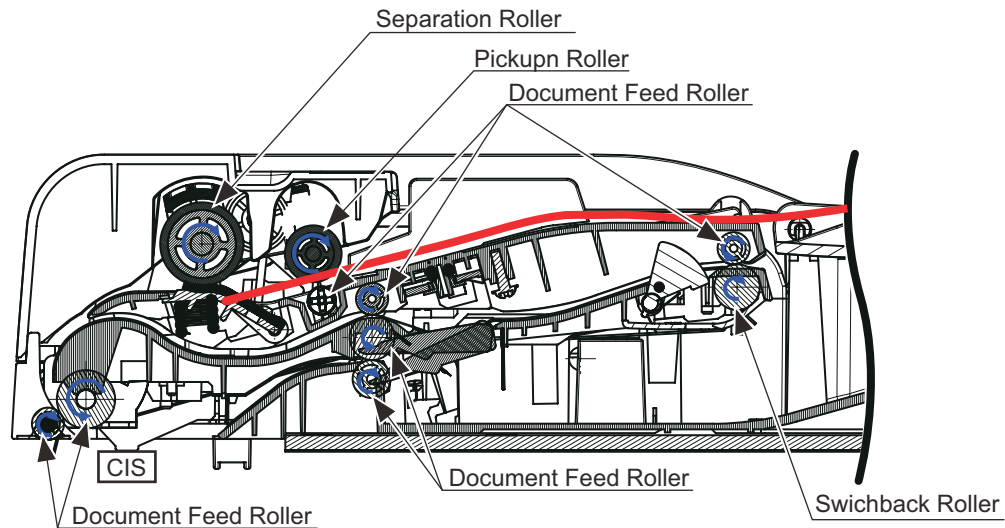

- DOCUMENT TRANSMISSION (ADF)

The frictional force between SEPARATION ROLLER (DOC.) and SEPARATION RUBBER makes PICK UP ROLLER (DOC.) move downward from standby position to pick up paper.

Pick-upped paper is separated by SEPARATION ROLLER (DOC.) and SEPARATION RUBBER (DOC.), and then fed by FEED ROLLER (DOC.).

After being read by CIS, the paper is ejected by ROLLER DOC EJECT.

Switchback path switching solenoid and switchback solenoid is always OFF.

- DOCUMENT TRANSMISSION (SCANNER GLASS)

CIS Module is carried by the belt timing along the shaft carriage to the reading start position.

Then it goes back to the home position reading the document through the glass.

6.20.4. Double side Scanning

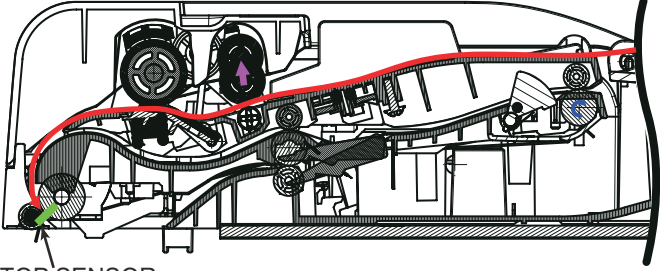
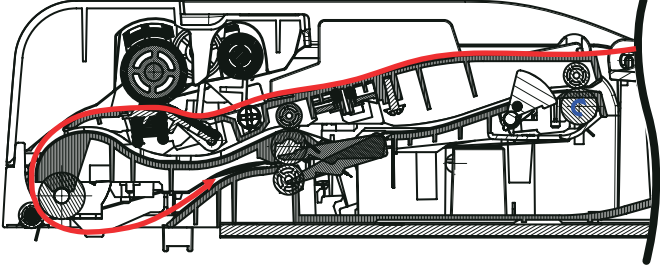
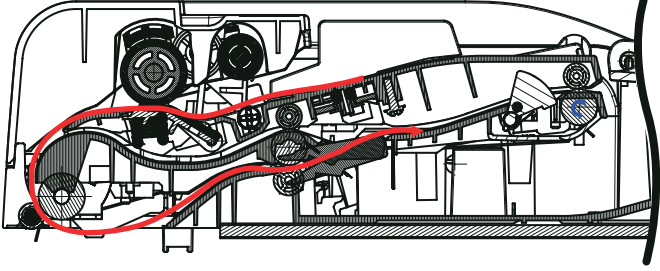
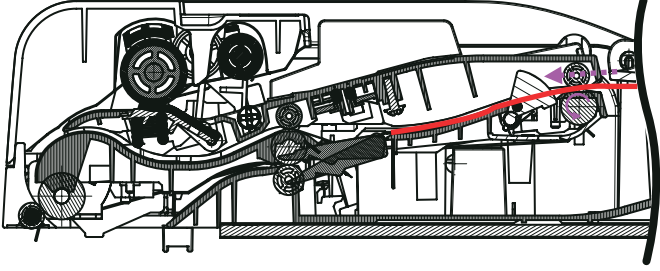
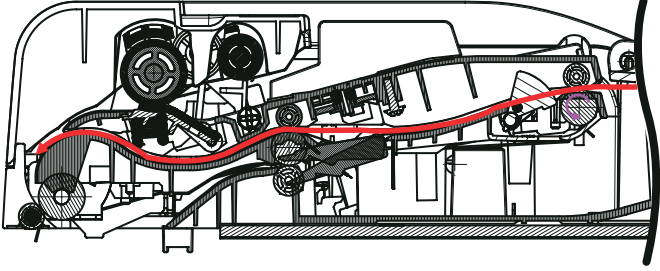
<p>1. When the paper arrive at TOP sensor, ADF motor reverse to up the pick up roller.</p>	 <p>TOP SENSOR</p>
<p>2. When the top of documents pass the CIS, paperpass change solenoid become "ON". Then document is fed to the upper paper pass.</p>	
<p>3. Then document is fed to the upper paper pass.</p>	
<p>4. When the end of document pass the paperpass change plate, switchback solenoid becomes "ON". The switchback roller rotate reverse, then the document start switchback. And paperpass change solenoid is "OFF".</p>	
<p>5. The document is fed to the ADF glass.</p>	

6. When the top of documents pass the CIS, paperpass change solenoid become "ON". Then document is fed to the upper paper pass.

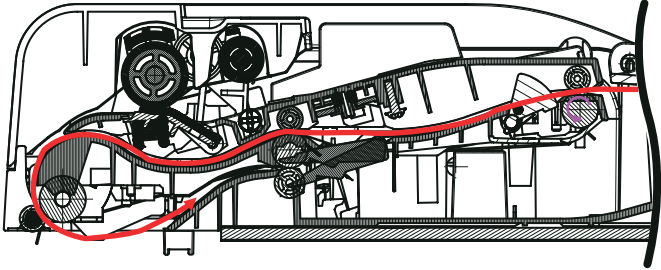

7. When the end of document pass the switchback roller, switchback solenoid "OFF" for changing the direction of rotation.

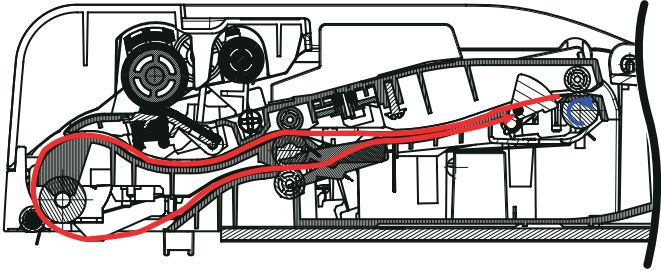

8. When the end of document pass the paperpass change plate, switchback solenoid becomes "ON". The switchback roller rotate reverse, then the document start switchback. And paperpass change solenoid is "OFF".

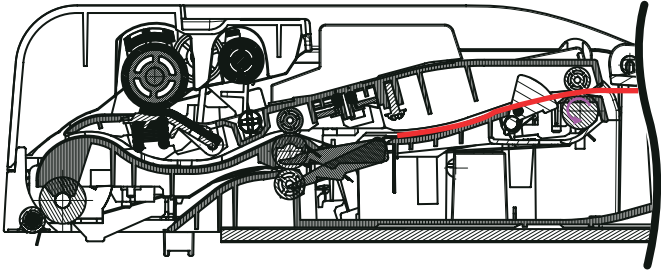

9. Paperpass change solenoid is "OFF". Switchback solenoid are "ON". The document pass the CIS(not scanning) and is finally ejected.

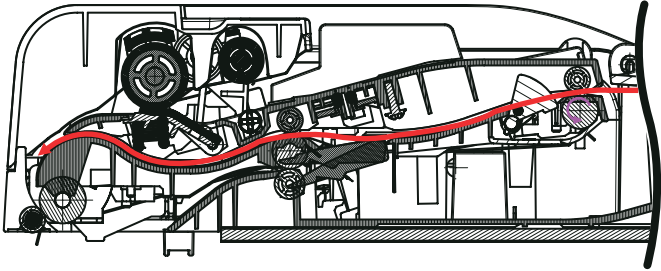

10. When the end of document pass the switchback roller, switchback solenoid is "OFF". The document pass the CIS(not scanning) and is finally ejected.

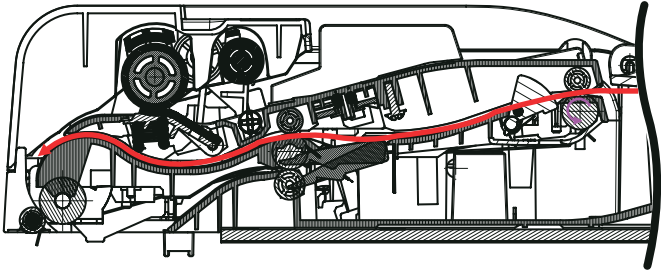

6.21. WirelessLAN Section (WirelessLAN supported models only)

WirelessLAN block consists of WirelessLAN module IC (IC850) and antenna switch IC (IC851).

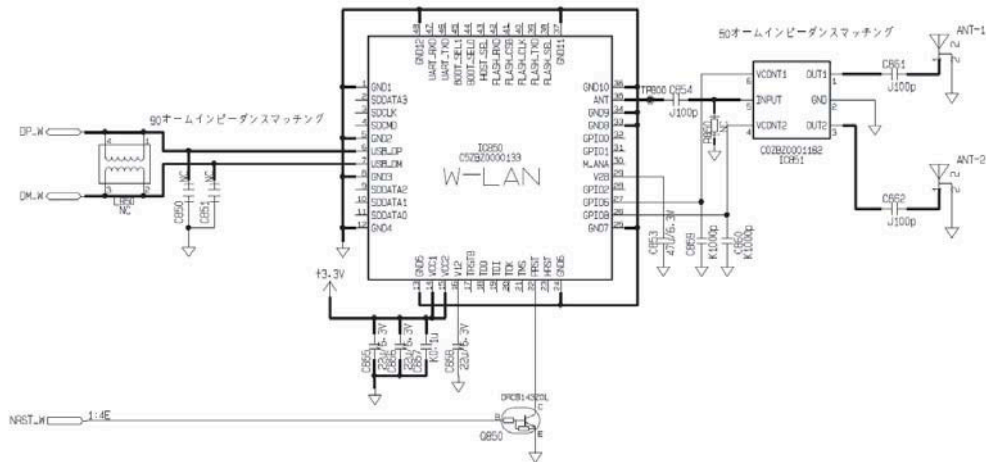

IC300 and IC850 communicate by USB2.0.

IC850 transmits and receives the signal of a 2.4GHz with an antenna 1 or antenna 2.

IC850 switches the antenna 1 and the antenna 2 using IC851.

IC851 input		antenna select	
Vcont1	Vcont2	ANT-1	ANT-2
Low	High	Enable	Disable
High	Low	Disable	Enable

7 Location of Controls and Components

7.1. Overview

7.1.1. Front View

■ KX-MB2230/KX-MB2270

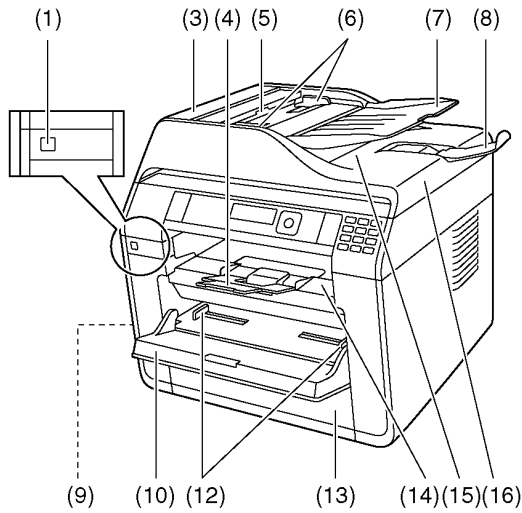

- (1) Power switch
- (2) USB port (KX-MB2515/KX-MB2545/KX-MB2575/DP-MB310 ONLY)
- (3) ADF (Automatic Document Feeder) cover
- (4) Output tray
- (5) Document entrance
- (6) Document guides
- (7) Document tray
- (8) Document sub tray
- (9) Speaker (KX-MB2230/KX-MB2270/KX-MB2545/KX-MB2575/DP-MB310 ONLY)
- (10) Manual tray (KX-MB2230/KX-MB2270 ONLY)
- (11) Multi-purpose tray (KX-MB2515/KX-MB2545/KX-MB2575/DP-MB310 ONLY)
- (12) Recording paper guides
- (13) Standard input tray
- (14) Recording paper exit
- (15) Document exit
- (16) Document cover

■ KX-MB2515

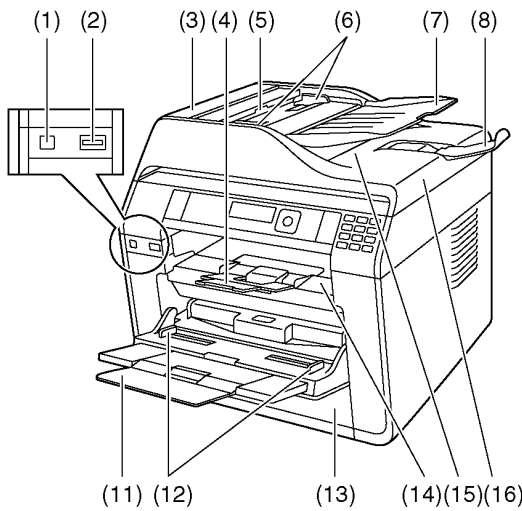

■ KX-MB2545/KX-MB2575/DP-MB310

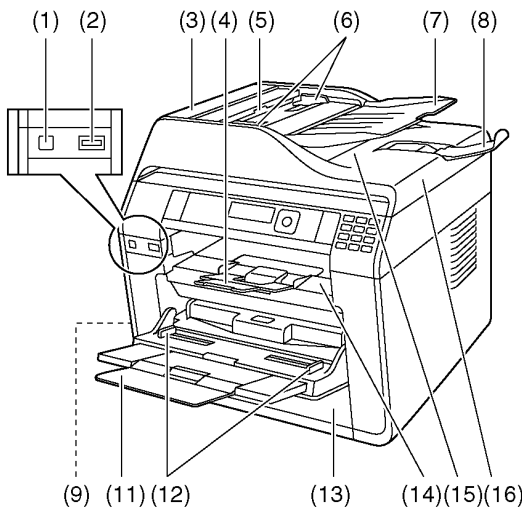

7.1.2. Rear View

■ KX-MB2230/KX-MB2270/KX-MB2545/ KX-MB2575/DP-MB310

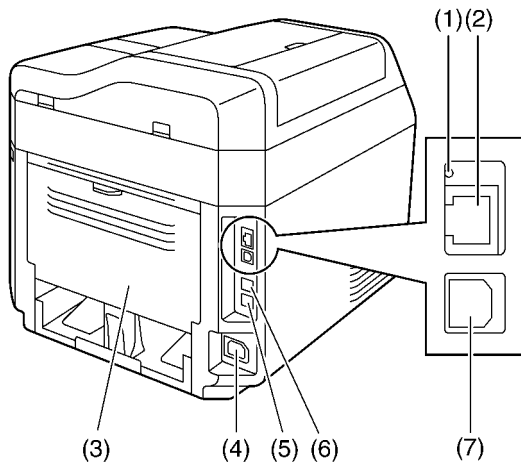

- (1) LED
- (2) LAN interface connector
 - 10Base-T/100Base-TX
- (3) Rear cover
- (4) Power inlet
- (5) Telephone line socket (KX-MB2230/KX-MB2270/KX-MB2545/KX-MB2575/DP-MB310 ONLY)
- (6) External telephone line socket (KX-MB2230/KX-MB2270/KX-MB2545/KX-MB2575/DP-MB310 ONLY)
- (7) USB interface connector

■ KX-MB2515

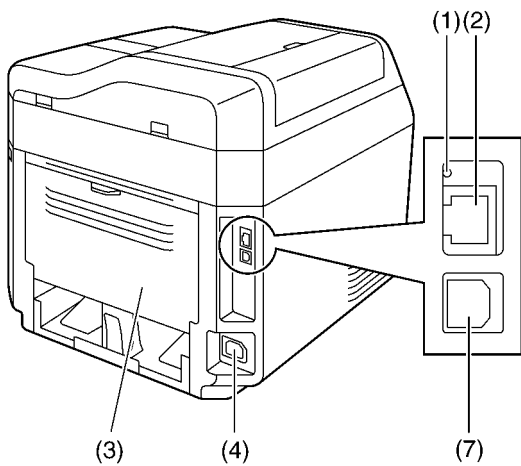

7.2. Control Panel

■ KX-MB2230/KX-MB2545

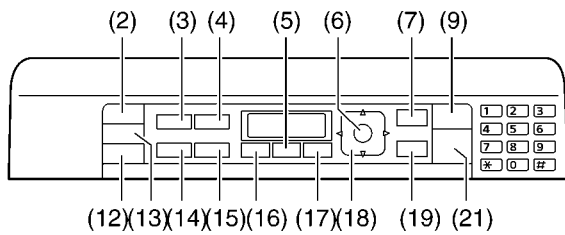

■ KX-MB2270/KX-MB2575

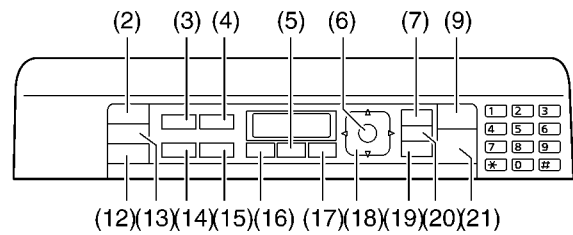

■ KX-MB2515

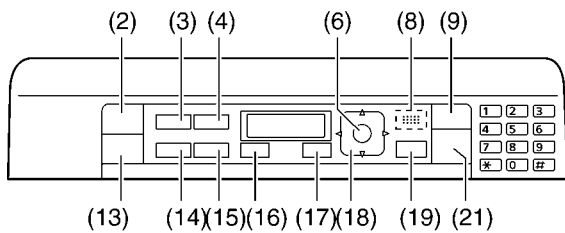

■ DP-MB310

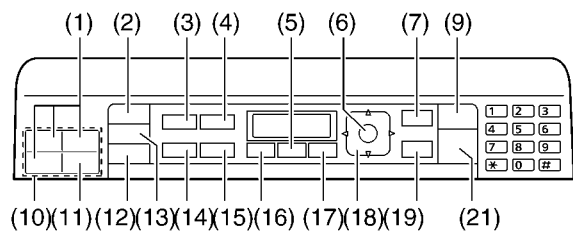

(1) [📡] *1 (Broadcast)

(2) [🔍] (Scan)

(3) [📄] (Quality)

[📄] (Quality)*2

(4) [📄] (Page Layout)

[✉] (Email)*3

(5) [🔊] (Monitor)*2

(6) [OK]

(7) [📞/📠] (Auto Answer)*2

(8) For beep sounds*4

(9) [⏹] (Stop)

(10) Station keys*1

(11) [📉] (Lower)*1

(12) [📠] (Fax)*2

(13) [📄] (Copy)

(14) [📄] (Copy Size)

[🔴] (Redial)*2

[⏸] (Pause)*2

(15) [📄] (Zoom)

[R] (Recall)*2

(16) [📄] (Duplex)

(17) [☰] (Menu)

(18) Navigator key

[📄] (Collate)

[📖] (Address book)*2

[📄] (Direct print)*6

(19) [ECO]

(20) [WPS]*7

(21) [▶] (Start)

Note:

*1 Only for models that support the one-touch dial feature/broadcast keys.

*2 Only for models that support the fax feature.

*3 Only for models that support Internet fax.

*4 Only for models without the fax feature.

*5 Only for models that support 2-sided scanning.

*6 Only for models with a USB port.

*7 Only for models that support wireless LAN.

8 Installation Instructions

8.1. Installation

8.1.1. Installation Space

The space required to install the unit is shown below.

The dimensions given are necessary for the unit to operate efficiently.

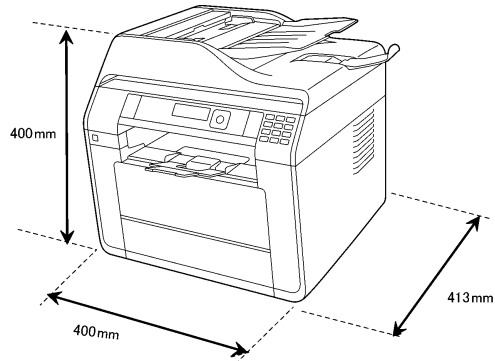

Note:

- Avoid excessive heat or humidity.
- Use the unit within the following ranges of temperature and humidity.
- Ambient temperature: 10°C to 32.5°C
- Relative humidity: 20% to 70% (without condensation)
- Power cord length should be less than 5 meters. Using a longer cord may reduce the voltage or cause malfunctions.
- Avoid direct sunlight.
- Do not install near devices which contain magnets or generate magnetic fields.
- Do not subject the unit to strong physical shock or vibration.
- Keep the unit clean. Dust accumulation can prevent the unit from functioning properly.
- To protect the unit from damage, hold both sides when you move it.
- Do not place the unit in an area where the paper tray may be obstructed. (i.e., by a wall, etc.)
- Keep this surface (1)(2) away from walls etc. more than 100 mm to let the unit cool down.

8.1.2. Recording Paper

Note for recording paper:

- We recommend that you test paper (especially special sizes and types of paper) on the unit before purchasing large quantities.
- Do not use the following types of paper:
 - Paper with cotton and/or fibre content that is over 20%, such as letterhead paper or paper used for resumes
 - Extremely smooth or shiny paper, or paper that is highly textured
 - Coated, damaged or wrinkled paper
 - Paper with foreign objects attached, such as tabs or staples
 - Paper that has dust, lint or oil stains
 - Paper that will melt, vaporize, discolour, scorch or emit dangerous fumes near 200°C, such as vellum paper. These materials may transfer onto the fusing roller and cause damage.
 - Moist paper
 - Inkjet paper
 - Chemically treated paper such as carbon or carbonless duplicating paper
 - Electrostatically charged paper
 - Badly curled, creased or torn paper
 - Paper with a coated surface
- Some paper is designed to be printed on only one side. Try printing on the other side of the paper if you are not happy with the print quality, or if misfeeding occurs.
- For proper paper feeding and best print quality, we recommend using long-grained paper.
- Do not use paper of different types or thicknesses at the same time. This may cause paper jams.
- Do not re-use paper printed from this unit for another printing job (including other copiers or printers). This may cause paper jams.
- To avoid curling, do not open paper packs until you are ready to use the paper. Store unused paper in the original packaging, in a cool and dry location.
- For customers who live in high humidity areas:
 - Please be sure to store paper in an air-conditioned room at all times. If you print using moist paper, it may cause paper jam.

8.1.2.1. Standard input tray

- If you load more than the specified amount of paper, a paper jam may occur and the paper may be damaged.
- Depending on the type of paper, the loaded paper may exceed the upper limit mark (▽). In this case, remove some paper from the tray.
- The unit is set for printing A4-size plain paper by default.
 - To use other paper sizes, change the recording paper size setting (feature #380).
 - To use other paper types, change the recording paper type setting (feature #383).

1. Pull the standard input tray (1) until it clicks into place, and then lift the front part of the tray and pull it completely out.

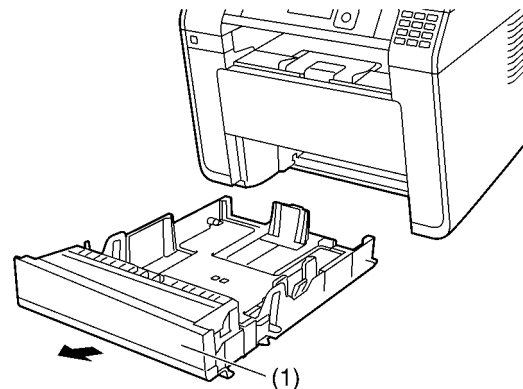

2. Before loading a stack of paper, fan the paper to prevent paper jams.

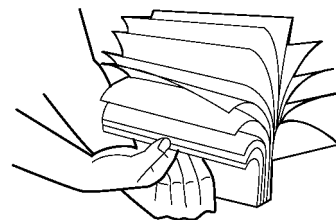

3. Adjust the back side of the recording paper guide.
For A4, letter, legal, 16K, 216 × 330 mm, 216 × 340 mm size paper:
Pinch the knob (1), and slide the input tray extender (2) to the appropriate position.

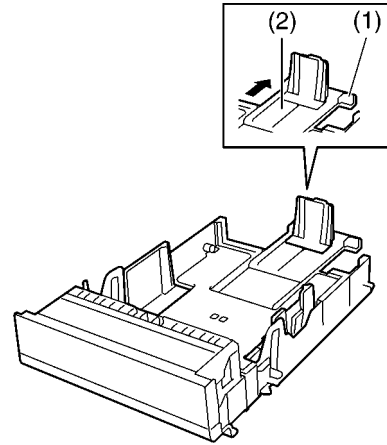

- For other size paper:**
If the input tray extender is extended, pinch the knob (1), and then slide it inside.

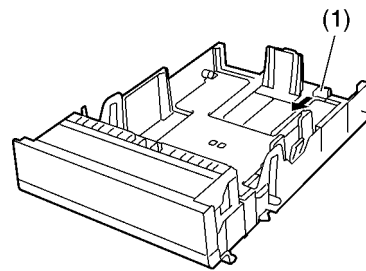

4. Load the paper, print-side down (1).
Important:
• Push down to lock the plate (2) in the Standard input tray, if necessary.

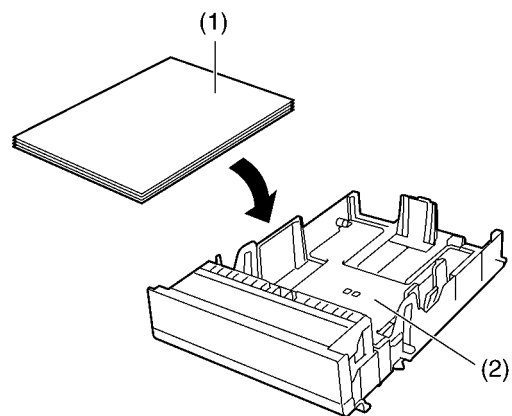

- If necessary, slide the recording paper guides to adjust the width to the size of the recording paper.
- Make sure that the recording paper is under the paper limit mark (1), and the paper should not be loaded over the snubbers (2).

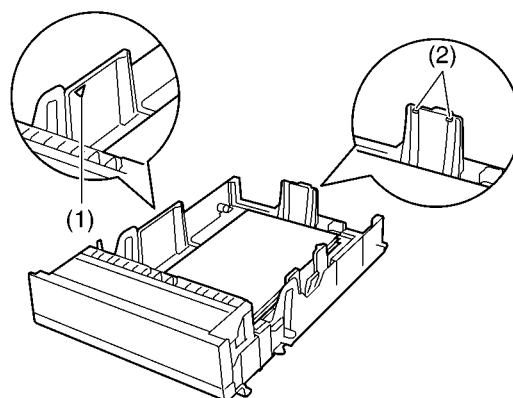
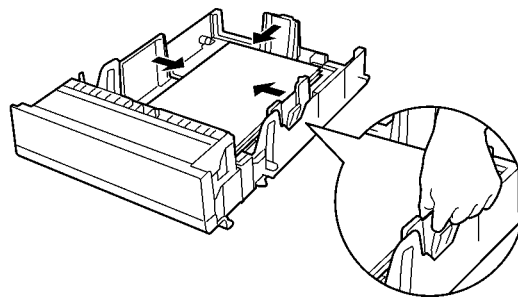

5. Insert the Standard input tray into the unit, lifting the front part of the tray. Then push it completely into the unit.

Note:

- If the paper is not loaded correctly, re-adjust the paper guides, or the paper may jam.
- If the Standard input tray does not close, the plate in the Standard input tray may not be in the locked position. Push the paper down and make sure that the paper is laying flat in the standard input tray.

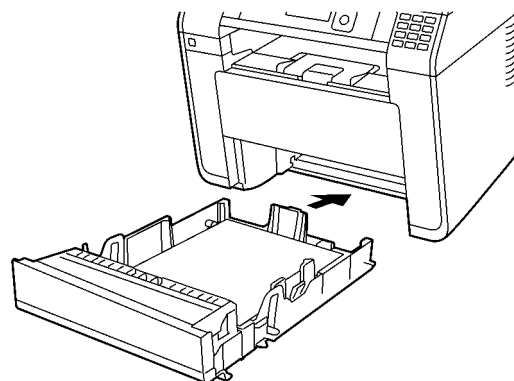

Caution for the Standard input tray

- Do not drop the Standard input tray.

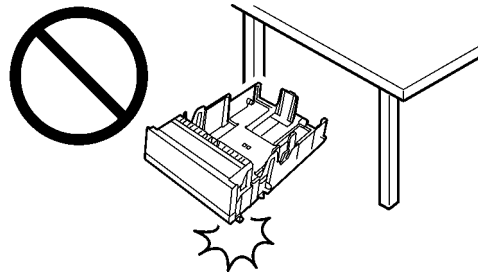

- Hold the Standard input tray with both hands when removing or installing. The Standard input tray weighs approximately 3.6 kg when fully loaded with recording paper.

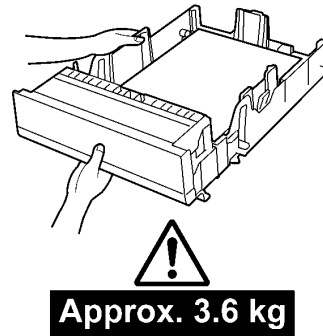

8.1.2.2. Manual tray/Multi-purpose tray

- When printing from a computer, custom size recording paper can also be used.
- The unit is set for printing A4-size plain paper by default.
 - To use other paper sizes, change the recording paper size setting (feature #381).
 - To use other paper types, change the recording paper type setting (feature #384).
- To print from the manual tray/multi-purpose tray, change the paper tray setting beforehand.
 - Select "#2" for the printer properties when printing with the computer.
 - Set the copy input tray setting to "#2" (feature #460) when making a copy.

Important:

- To print on thick paper, label, envelope or Japan postcard:
 - Be sure to open the rear cover before starting and print one sheet at a time. The recording paper will be printed out from the rear side. Therefore, if you print with the cover closed, the paper may jam inside the unit.
 - Be sure to close the rear cover after printing.

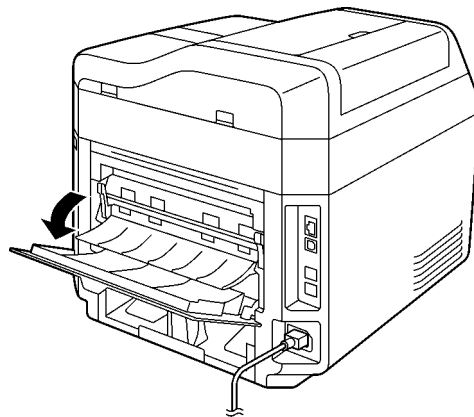

Manual tray

It can hold one sheet at a time. When printing or copying multiple sheets, add the next sheet after the first sheet has been fed into the unit.

1. Adjust the width of the guides (1) to the size of the recording paper.
 - If the unit is in sleep mode, press a key to put the unit in standby mode for the next process.
2. Insert the paper, print-side up (2) until the unit grasps the paper and a single beep is heard.

Note:

- The manual tray cannot be used for receiving faxes.
- If the copy input tray setting (feature #460) is not set "#2" beforehand, when printing or copying multiple pages, the 1st page will be printed from the manual tray, but the rest of the pages will be printed from the standard input tray.

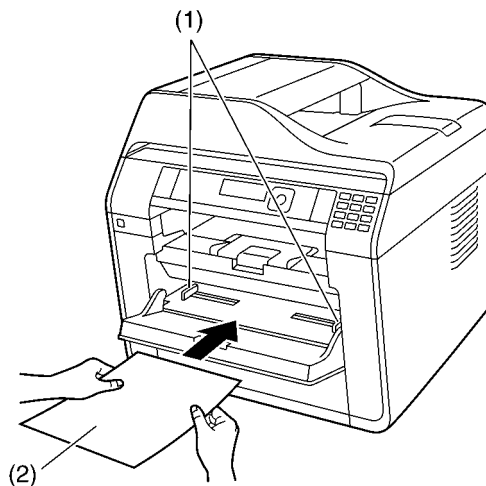

Multi-purpose tray

It can hold 50 sheets at a time.

1. Expand the multi-purpose tray.

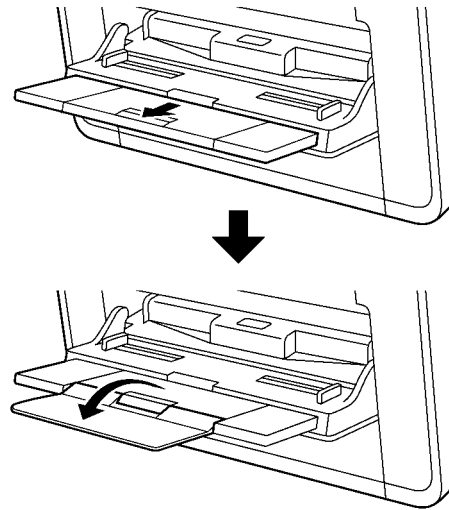

2. Adjust the width of the guides (1) to the size of the recording paper. Then, load the paper, print-side up (up to 50 sheets).

Note:

- If the paper is not inserted correctly, re-adjust the paper, or the paper may jam.
- Please make sure that the pickup lever (2) is firmly raised when setting the recording paper. If the pickup lever is not raised, raise the pickup lever.

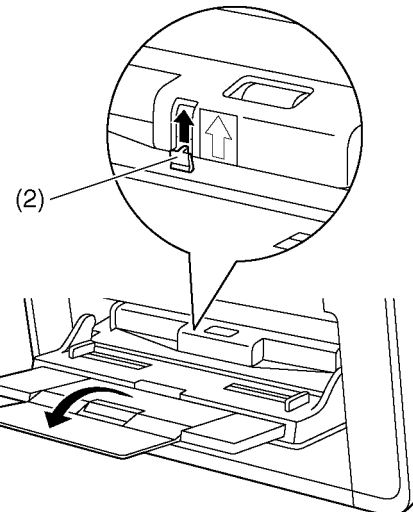
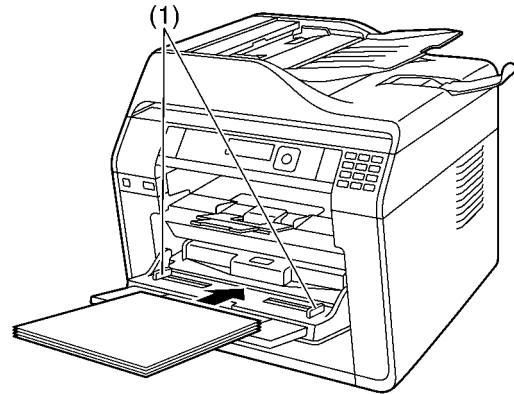

8.1.3. Documents the Unit Can Send

Note:

- Confirm that there are no documents in the automatic document feeder.
- Place the original onto the scanner glass gently. To avoid malfunction, do not press down too firmly.
- If the original is a book thicker than 15mm, do not close the document cover.
- Confirm that any ink, paste or correction fluid has dried completely, as this may mark the scanner glass.
- Effective scanning area is shown by the shaded area.

Effective scanning area

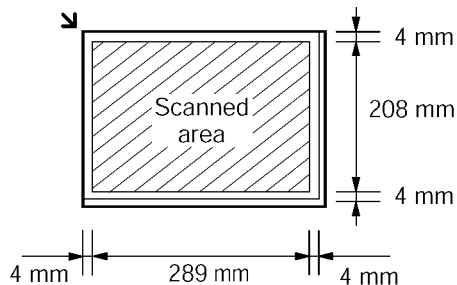

8.1.4. Using the Automatic Document Feeder

1. Open the document tray (1) and the document sub tray (2).
 - To open the document sub tray, press its centre part (3).

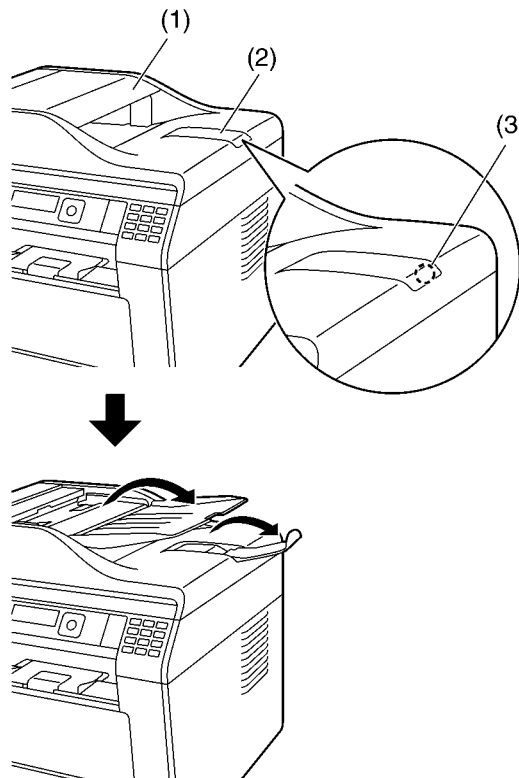

2. Insert the document (up to 50 sheets) FACE UP into the feeder until a single beep is heard.
 - To make a portrait copy, set the original in portrait direction. To make a landscape copy, set the original in landscape direction.

3. • For A6 size documents, always insert the document in portrait direction (insert long edge into the feeder).
 • Adjust the width of the document guides (1) to fit the actual size of the document.

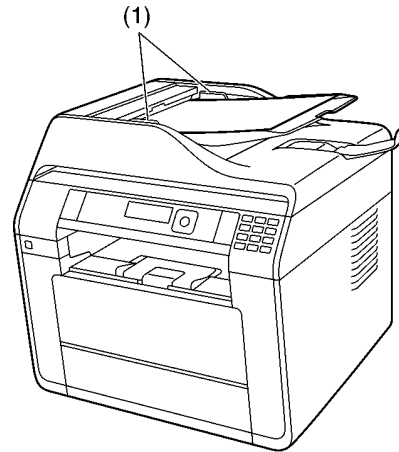

Note:

- Do not place the unit in an area where the document sub tray may be easily bumped into.
- Confirm that there are no documents on the scanner glass.
- Confirm that any ink, paste or correction fluid has dried completely.
- Remove clips, staples or other fasteners.
- Do not insert the following types of documents (Make a copy of the document using the scanner glass and set the copy instead.):
 - Chemically treated paper such as carbon or carbonless duplicating paper
 - Electrostatically charged paper
 - Badly curled, creased or torn paper
 - Paper with a coated surface
 - Paper with printing on the opposite side that can be seen through the other side, such as newsprint
- When feeding certain types of document (for example, if back of the page is not clean) through the automatic document feeder, it is possible that dirty marks may be left on the original document. To prevent this, we recommend feeding the document one page at a time when using the automatic document feeder, or to use the scanner glass.
- The total height of the documents when laid flat, must be less than 7mm. If the documents exceed the capacity of the automatic document feeder, they may fall or cause a jam in the feeder.
- To set a document with a width of less than 210 mm, we recommend using the scanner glass to copy the original document onto A4 or letter-size paper, then setting the copied document for better results.
- Do not set documents that do not satisfy the requirements of size and weight. Make a copy of the document using the scanner glass and set the copy.
- Available document size, document weight and effective scanning area are as follows:

Minimum document size Maximum document size Effective scanning area

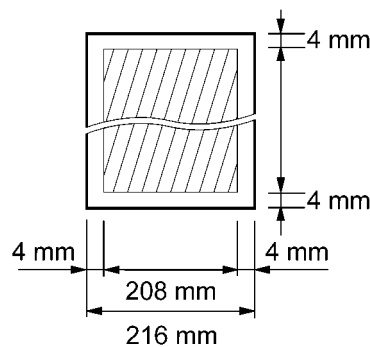
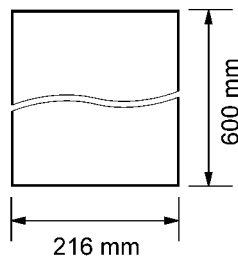
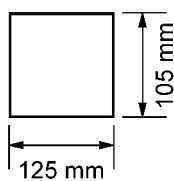

Document weight

- Single sheet: 60 g/m² to 75 g/m²
- Multiple sheets: 60 g/m² to 75 g/m²

- Shaded area will be scanned.
- For 2-sided scanning, the minimum document size is 148 mm × 210 mm.
- For 2-sided scanning, the maximum document size is 216 mm × 356 mm.
- When using the unit as a scanner, the effective scanning length depends on the selected paper size.

8.1.5. Toner Cartridge and drum cartridge

The supplied toner cartridge is a starter toner cartridge.

- When using the unit for the first time, please use the starter toner cartridge.

Caution:

- Read the following instructions before you begin installation.
 - The drum cartridge contains a photosensitive drum. Exposing it to light may damage the drum.
 - Do not expose the drum cartridge to light for more than 5 minutes.
 - Do not touch or scratch the drum surface (1).

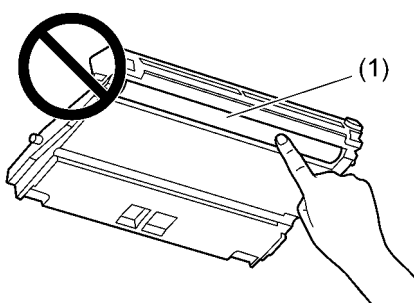
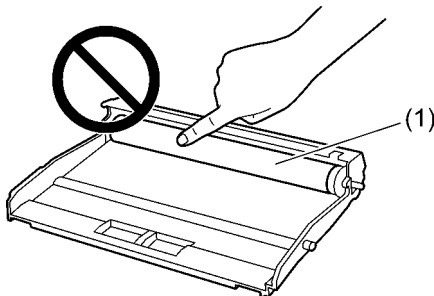

- Do not place the drum cartridge near dust or dirt, or in a high humidity area.
- Do not expose the drum cartridge to direct sunlight.
- Do not leave the toner cartridge out of the protective bag for a long time. It will affect the printing quality.
- Do not add toner to the toner cartridge. We cannot be responsible for any damage to the unit or degradation of print quality which may occur from the use of a non-Panasonic toner cartridge and drum cartridge.

Note:

- Close the manual tray/multi-purpose tray and output tray before opening the front cover.

1. Press the button (1) and open the front cover.

For KX-MB2230/KX-MB2270:

- If the unit is in sleep mode, press a key to put the unit in standby mode for the next process when replacing the toner cartridge.

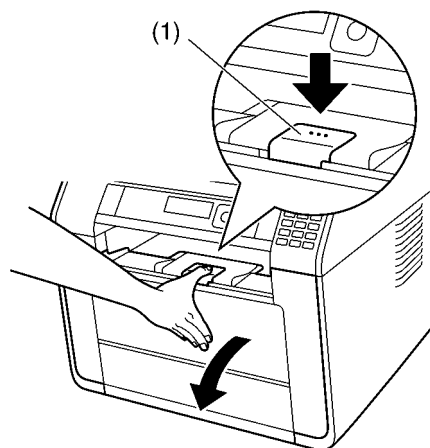

2. Remove the drum cartridge (1), which is pre-installed in the unit.

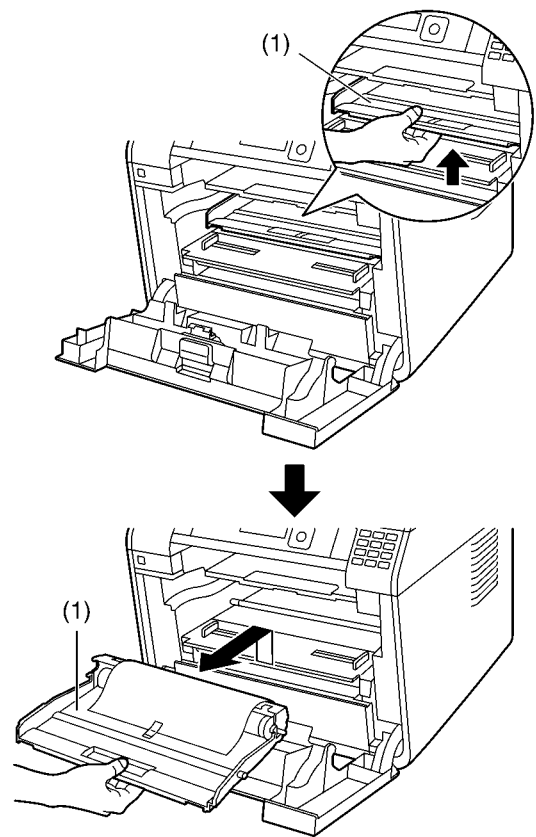

3. Remove the protective sheet (1) from the drum cartridge.
- Do not touch or scratch the drum surface.
 - "PAPER JAMMED" is displayed before the protective sheet is removed.
 - After removing the protective sheet, re-install the drum cartridge and lock it into place.

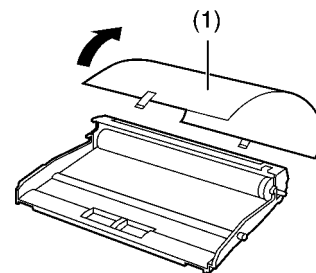

4. Remove the toner cartridge (1) from the protective bag.

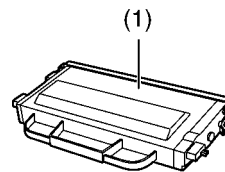

5. Shake the toner cartridge horizontally more than 5 times.

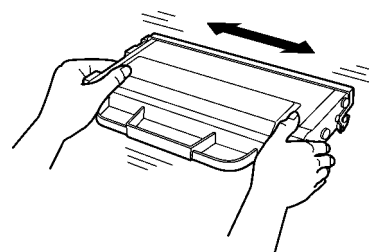

6. Detach the orange protective cover (1) from the toner cartridge.
• Do not touch the roller.

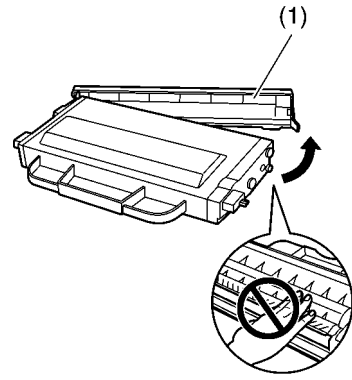

7. Hold the toner cartridge (1) by the centre handle, then insert firmly to lock into place.

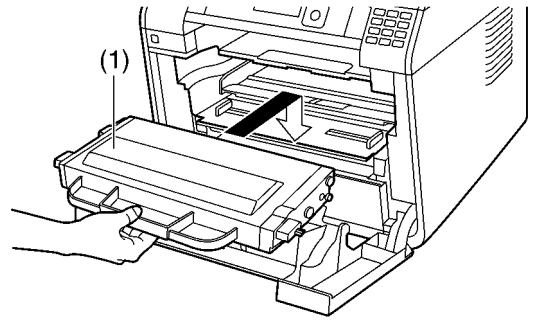

8. Close the front cover.

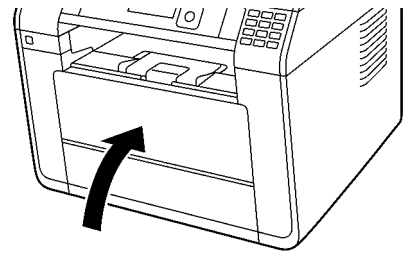

8.1.5.1. When to replace the toner cartridge and drum cartridge

When the display shows the following, replace the toner cartridge.

- "TONER EMPTY"
- "TONER LIFE OVER"

When the display shows the following, the toner cartridge is coming to the end of its useful life. Please be prepared to replace the cartridge soon.

- "TONER LOW"
- "TONER LIFE LOW"

When the display shows the following, replace the drum cartridge.

- "DRUM LIFE LOW"
- "DRUM LIFE OVER"

Toner cartridge life and drum cartridge life

- If the printing quality is still poor or "DRUM LIFE OVER" appears on the display, replace the toner cartridge and drum cartridge.
- To maintain print quality and machine life, we recommend that you clean slots and openings and the inside of the unit when replacing the toner cartridge and/or drum cartridge.

Note:

- To ensure that the unit operates properly, we recommend the use of Panasonic toner cartridge and drum cartridge. (Refer to **Accessory information** (P.14).)

Waste disposal method

Waste material should be disposed of under conditions which meet all national and local environmental regulations.

Toner save feature

- If you want to reduce toner consumption, set the toner save setting to ON (feature #482) The toner cartridge will last approximately 20% longer. This feature may lower the print quality.

8.1.6. Required Computer Environment

Refer to **Hardware Requirements for Multi-Function Software** (P.28).

8.1.7. Installing software (including printer, scanner and other drivers)

Panasonic Multi-Function Station software enables the unit to carry out the following functions:

- Printing on plain paper, thin and thick paper, labels, envelope and Japan postcard
 - Displaying the preview of the print image, changing the page order, deleting pages, and changing the print layout etc. before printing (Easy Print Utility)
 - Scanning documents and converting an image into text with OCR software
 - Scanning from other applications for Microsoft® Windows® that support TWAIN scanning and WIA scanning (USB connection only)
 - Storing, editing or erasing items in the address book using your computer
 - Programming the features using your computer
 - Sending, receiving fax documents using your computer (Fax supported models only)
- **Install Multi-Function Station (CD-ROM) before connecting the unit to a computer with the USB cable. If the unit is connected to a computer with the USB cable before installing Multi-Function Station, the [Found New Hardware Wizard] dialogue box may appear. Click [Cancel] to close it.**
 - **Software features and appearance are subject to change without notice.**

1 Start Windows and exit all other applications.

- You must be logged in as an administrator in order to install Multi-Function Station.

2 Insert the supplied CD-ROM into your CD-ROM drive.

- If the **[Select Language]** dialogue box appears, select the language that you want to use with this software. Click **[OK]**.
- If the installation does not start automatically:
Click **[Start]**. Choose **[Run...]**. Type **"D:\Install"** (where **"D"** is the drive letter of your CD-ROM drive). Click **[OK]**.
(If you are not sure what the drive letter is for your CD-ROM drive, use Windows Explorer and look for the CD-ROM drive.)

3 **[Easy Installation]**

- The installation will start automatically.

4 When the setup program starts, follow the on-screen instructions.

- Easy Print Utility and Device Monitor will also be installed.

5 The **[Connection Type]** dialogue box appears.

For USB connection:

1. **[Connect directly with a USB cable.]** → **[Next]**.
 - The **[Connect Device]** dialogue box will appear.
2. Connect the unit to a computer with the USB cable (1), then click **[Next]**.

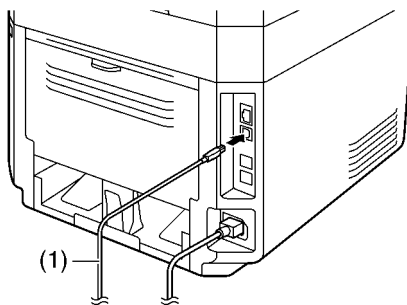

- If the unit is connected to your computer, the model name will be automatically detected.
 - You can change the name of the unit if necessary.
3. Click **[Install]**, then follow the on-screen instructions.
 - The files will be copied to your computer.

For LAN connection :

1. **[Connect via the Network.]** → **[Next]**.
 - The **[Select a Network Device]** dialogue box will appear.
2. Check **[Select from the search list]** and select the unit from the list.
 - If the name of the desired unit is not displayed on the list, and the IP address for the unit has been assigned, check **[Direct input]** and enter the IP address.
3. **[Next]**.
 - You can change the name of the unit if necessary.
4. Click **[Install]**, then follow the on-screen instructions.
 - The files will be copied to your computer.

Important notice

When installing using a USB cable connection, a message may appear during the software installation. This is normal and the software will not cause any difficulties with your operating system. You can continue the installation with no problem. This kind of message is displayed:

- **For Windows XP users**

“The software you are installing for this hardware has not passed Windows Logo testing to verify its compatibility with Windows XP.”

- **For Windows Vista / Windows 7 / Windows 8 users**

“Would you like to install this device software?”

8.2. Connections

Caution:

- When you operate this product, the power outlet should be near the product and easily accessible.
- Be sure to use the telephone line cord supplied with this unit (fax supported models only).
- Do not extend the telephone line cord (fax supported models only)

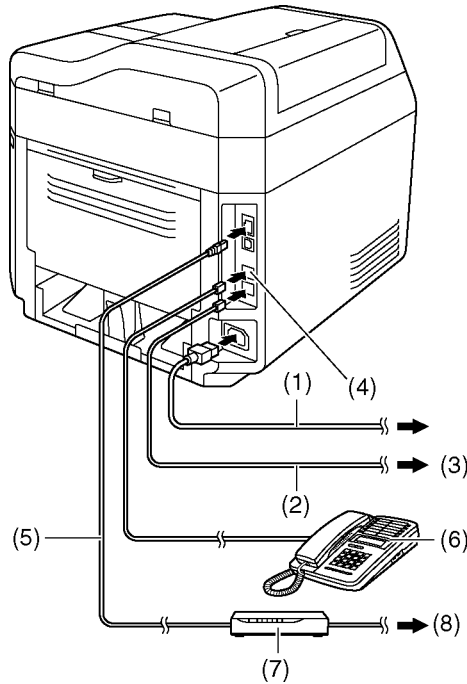

- (1) Power cord
 - Connect to a power outlet (220-240 V, 50 Hz).
- (2) Telephone line cord*¹
 - Connect to a single telephone line socket.
- (3) To a single telephone line socket
 - For users in Germany and Austria**, use the appropriate telephone line cord.

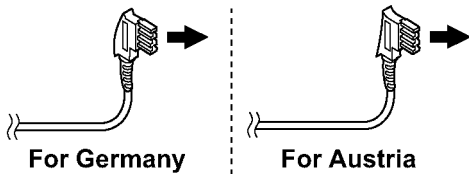

- (4) [EXT] socket*¹
 - You can connect an answering machine or an extension telephone. Remove the stopper if attached, and take care of it appropriately.
- (5) LAN cable (not supplied)*²
 - To assure continued emission limit compliance, use only shielded LAN cable (Category 5 (Cat-5) Ethernet cable).
- (6) Answering machine (not supplied)*^{1*3}
 - Extension telephone (not supplied)*^{1*4}
- (7) Network router/Network hub (not supplied)*²
 - Also connect networked computers.
- (8) To the internet*²
 - *1 Fax supported models only
 - *2 LAN supported models only
 - *3 For France and Belgium only
 - *4 For countries other than France and Belgium only

IMPORTANT NOTICE FOR THE USB CONNECTION

- DO NOT CONNECT THE UNIT TO A COMPUTER WITH THE USB CABLE UNTIL PROMPTED TO DO SO DURING THE SETUP OF MULTI-FUNCTION STATION.

Note:

- An earthed contact socket should be used when connecting the unit to the power outlet (for Poland only).
- Do not place any objects within the following distance:
 - Right and left side: 10 cm
 - Back side: 20 cm
- Do not cover slots and openings on the unit. They are provided for ventilation and protection against overheating.
- If another device is connected to the same telephone line as this unit, you may experience unexpected problems as this unit is not designed to share a telephone line (fax supported models only).
- A telephone handset cannot be connected directly to this unit. To talk to the other party, please connect an extension telephone (fax supported models only)
- If you use the unit with a computer and your internet provider instructs you to install a filter (9), please connect it as follows. (fax supported models only)

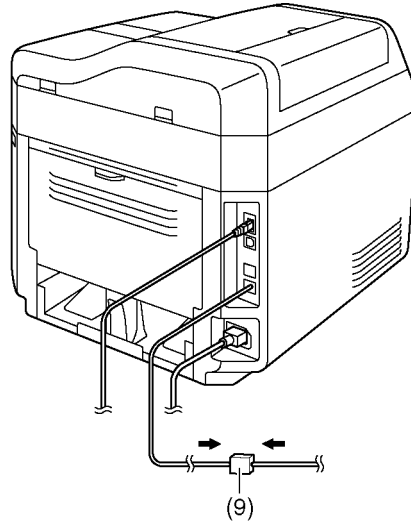

**For Germany and Austria only:
Connector pinouts (fax supported models only)**

Socket "To phone line"

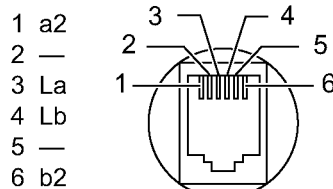

Using network router/network hub (LAN supported models only)

- We recommend using network routers/network hubs (7) under secure network environments. Consult your network administrator for firewall settings, etc.
- The warranty does not cover damage due to security problems or any inconveniences relating to it.

9 Operating Instructions

9.1. Your Logo (Fax supported models only)

You can program your logo (name, company name, etc.) so that it appears on the top of each page sent.

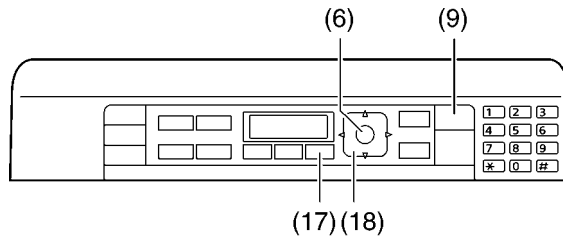

- 1 **[■](17) → [✱](9)[1][0][2] → [OK](6).**
- 2 Enter your logo, up to 30 characters
- 3 **[OK](6) → [■](17)**

To correct a mistake

Press **[◀]** or **[▶]** (18) to move the cursor to the incorrect character, and make the correction.

- To erase all characters, press and hold **[⊗](9)**.

9.2. Character Entry (Fax or LAN supported models only)

The dial keypad is used to enter characters and numbers.

- Press [◀] or [▶] to move the cursor.
- Press the dial keys to enter characters and numbers.
- Press [⊗] to erase the character or number highlighted by the cursor. Press and hold [⊗] to erase all characters or numbers.
- To enter another character located on the same dial key, press [▶] to move the cursor to the next space, then press the appropriate dial key.

[0]*1*2	[1]*1	[*]	[R]	[⊗]	[⊗]
0 @ () < > ! " # \$ % & \ ¥ * ^ ' ~ →	1 . _ - [] { } + / = , ' ; ; ?	To switch between uppercase or lowercase letters.	Hyphen	To insert a space.	To delete a character.

*1 Several types of symbols cannot be entered for certain features.

*2 " " maybe displayed as "¥" in some case.

■ The following depends on the language selection (feature #110)

"ENGLISH", "CZECH", "HUNGARIAN", "SLOVAK", "FRENCH", "TURKISH"

[2]	[3]	[4]	[5]	[6]	[7]	[8]	[9]
A B C 2	D E F 3	G H I 4	J K L 5	M N O 6	P Q R S 7	T U V 8	W X Y Z 9
a b c 2	d e f 3	g h i 4	j k l 5	m n o 6	p q r s 7	t u v 8	w x y z 9

"GERMAN"

[2]	[3]	[4]	[5]	[6]	[7]	[8]	[9]
A Ä Ã B C 2	D E È F 3	G H I Ì 4	J K L 5	M N O Ö Ö 6	P Q R S 7	T U Û Ü V 8	W X Y Z 9
a à ä b c 2	d e è f 3	g h i ì 4	j k l 5	m n o ö ö 6	p q r s ß 7	t u ù ü v 8	w x y z 9

"POLISH"

[2]	[3]	[4]	[5]	[6]	[7]	[8]	[9]
A Ą B C Ć 2	D E Ę F 3	G H I 4	J K L Ł 5	M N Ń O Ó 6	P Q R S Ś 7	T U V 8	W X Y Z Ż 9
a ą b c 2	d e ę f 3	g h i 4	j k l 5	m n o 6	p q r s 7	t u v 8	w x y z 9

"PORTUGUESE", "SPANISH"

[2]	[3]	[4]	[5]	[6]	[7]	[8]	[9]
A Á Ã B C Ç 2	D E É F 3	G H Í 4	J K L 5	M N Ñ O Ó Ö 6	P Q R S 7	T U Ú V 8	W X Y Z 9
a á ã b c ç 2	d e é f 3	g h í 4	j k l 5	m n ñ o ó õ 6	p q r s 7	t u ú v 8	w x y z 9

9.2.1. To Select Characters Using [▼] or [▲]

Instead of pressing the dial keys, you can select characters using [▼] or [▲].

1. Press [▼] repeatedly to display the desired character. Characters will be displayed in the following order:

- ① Uppercase letters
- ② Numbers
- ③ Symbols
- ④ Lowercase letters*¹

*¹ When you enter email address (i.e. scan to email address feature), lowercase letters will be displayed first (LAN supported models only).

- If you press [▲], the order will be reversed.

2. Press [▶] to insert the displayed character.

3. Return to step 1 to enter the next character.

10 Test Mode

10.1. Test Functions

The codes listed below can be used to perform simple checks of some of the unit's functions. When complaints are received from customers, they provide an effective tool for identifying the locations and causes of malfunctions.

Test Mode	Type of Mode	Code	Function
		Operation after code input	
MEMORY CLEAR	Service Mode	"5" "5" "0"	Clear the memory where the users can store data.
		SET	
MOTOR TEST	Service Mode	"5" "5" "6"	00:printer motor feed 10:auto document feed 20:carriage
		SET	
MODEM TEST (Fax supported models only)	Service Mode	"5" "5" "4"	Telephone line circuit is connected automatically, output the following signals on the circuit line. 1) OFF 2) 1,100Hz 3) 2,100Hz 4) ANSam 5) CI 6) CM 7) JM 8) INFO0c 9) INFO0a 10) ToneB 11) ToneA 12) Lprob 13) CCH Org 14) CCH Ans 15)V21 300bps 16) V27 2,400bps 17) V27 4,800bps 18) V29 7,200bps 19) V29 9,600bps 20) V17 7,200bps 21) V17 9,600bps 22) V17 12,000bps 23) V17 14,400bps 24) V34 2,400bps 25) V34 4,800bps 26) V34 7,200bps 27) V34 9,600bps 28) V34 12,000bps 29) V34 14,400bps 30) V34 16,800bps 31) V34 19,200bps 32) V34 21,600bps 33) V34 24,000bps 34) V34 26,400bps 35) V34 28,800bps 36) V34 31,200bps 37) V34 33,600bps
		SET	
ROM CHECK	Service Mode	"5" "5" "1"	Indicates the version and checks the sum of the ROM.
		SET	
LCD TEST	Service Mode	"5" "5" "8"	Checks the LCD indication. Illuminates all the dots to check if they are normal.
		SET	
DTMF SINGLE TONE TEST (Fax supported models only)	Service Mode	"5" "5" "2"	Outputs the DTMF as single tones. Used to check the frequencies of the individual DTMF tones. Refer to DTMF Single Tone Transmit Selection (P.137) .
		1...ON 2...OFF	
LED TEST	Service Mode	"5" "5" "7"	All LEDs above the operation panel board flash on and off, or are illuminated.
KEY TEST	Service Mode	"5" "6" "1"	Checks the button operation. Indicates the button code on the LCD while the button is pressed. Refer to Button Code Table (KX-MB2230/KX-MB2545 ONLY) or Button Code Table (KX-MB2270/KX-MB2575 ONLY) (P.138).
		START (any key)	
SCANNER TEST	Service Mode	"5" "5" "5"	LED lights up, Scanner scanning. 1:RED / 2:GREEN / 3:BLUE / 4:monochrome / 5:Color
LSU TEST	Service Mode	"6" "3" "9"	Laser radiates, Polygon rotates
		SET	
High Voltage Power Supply Board CHECK	Service Mode	"6" "2" "8"	
		SET	
FAN TEST	Service Mode	"6" "7" "7"	01:TEST OFF 02:FAN 1 High-speed rotation 03:FAN 1 Low-speed rotation 04:FAN 1 STOP
MEMORY CLEAR (except History data)	Service Mode	"7" "1" "0"	Refer to Memory Clear Specification (P.145) .
		SET	
PRINT TEST PATTERN	Service Mode	"8" "5" "2"	1. Press "852" then the SET key in the service mode. 2. As "PATNO. =" is displayed on the LCD, enter the test pattern No. and press the SET key. 3. When "NO. =" is displayed on the LCD, enter the printing number and press the SET key. (Press "00" for the infinite printing.) 4. "MODE=" is displayed on the LCD. Press "0" to start printing or press "1" to go to the next screen. 5. When "1" is pressed at MODE, "INTVL = " is displayed on the LCD. Enter the printing interval (000~999 sec). 6. The printing repeats the designated number of times at the programmed printing intervals. Refer to Print Test Pattern (P.140) .

Test Mode	Type of Mode	Code	Function		
		Operation after code input			
SENSOR CHECK	Service Mode	"8" "1" "5"	<p>First of all, press the copy button, and confirm the action of ON/OFF. For each sensor's operation, refer to Sensors and Switches Section (P.77). LCD DISPLAY:</p> <div style="border: 1px solid black; padding: 5px; width: fit-content; margin: 10px auto;"> <p>D S C P R E * T K N B * 3 F D F C U T * * * D M A N C * * * P U</p> </div> <table style="width: 100%; border: none;"> <tr> <td style="vertical-align: top; width: 50%;"> <p>D: Document D: Document set -: No document</p> <p>S: Read position S: Document detect -: No document</p> <p>C: Front cover C: Cover open -: Cover close</p> <p>P: Standard cassette recording paper P: Paper detect -: No paper</p> <p>R: Registration R: Paper detect -: No paper</p> <p>E: Paper exit E: Paper detect -: No paper</p> <p>*: None</p> <p>T: Toner T: Toner detect -: No toner</p> <p>K: Toner Cartridge contact K: Contact -: No contact</p> <p>N: First use Toner Cartridge N: New -: Secondhand</p> <p>B: Rear cover B: Cover open -: Cover close</p> <p>*: None</p> <p>3F: Fuser thermistor 3F: 00 (high temp.) - FF (low temp.)</p> <p>DF: Room thermistor DF: 00 (high temp.) - FF (low temp.)</p> </td> <td style="vertical-align: top; width: 50%;"> <p>C: Cassette open and close C: Cassette open -: Cassette close</p> <p>U: Pickup U: Paper detect -: No paper</p> <p>T: Print timing T: Paper detect -: No paper</p> <p>*: None</p> <p>*: None</p> <p>*: None</p> <p>D: ADF Duplex D: Document detect -: No document</p> <p>M: MPT paper M: Paper set -: No paper</p> <p>A: ADU A: Paper detect -: No paper</p> <p>N: First use drum sensor N: New -: Secondhand</p> <p>C: Drum contact sensor C: Contact -: No contact</p> <p>*: None</p> <p>*: None</p> <p>*: None</p> <p>P: Expansion PAPER sensor P: Paper set -: No paper</p> <p>U: Expansion Pickup sensor U: Paper detect -: No paper</p> </td> </tr> </table>	<p>D: Document D: Document set -: No document</p> <p>S: Read position S: Document detect -: No document</p> <p>C: Front cover C: Cover open -: Cover close</p> <p>P: Standard cassette recording paper P: Paper detect -: No paper</p> <p>R: Registration R: Paper detect -: No paper</p> <p>E: Paper exit E: Paper detect -: No paper</p> <p>*: None</p> <p>T: Toner T: Toner detect -: No toner</p> <p>K: Toner Cartridge contact K: Contact -: No contact</p> <p>N: First use Toner Cartridge N: New -: Secondhand</p> <p>B: Rear cover B: Cover open -: Cover close</p> <p>*: None</p> <p>3F: Fuser thermistor 3F: 00 (high temp.) - FF (low temp.)</p> <p>DF: Room thermistor DF: 00 (high temp.) - FF (low temp.)</p>	<p>C: Cassette open and close C: Cassette open -: Cassette close</p> <p>U: Pickup U: Paper detect -: No paper</p> <p>T: Print timing T: Paper detect -: No paper</p> <p>*: None</p> <p>*: None</p> <p>*: None</p> <p>D: ADF Duplex D: Document detect -: No document</p> <p>M: MPT paper M: Paper set -: No paper</p> <p>A: ADU A: Paper detect -: No paper</p> <p>N: First use drum sensor N: New -: Secondhand</p> <p>C: Drum contact sensor C: Contact -: No contact</p> <p>*: None</p> <p>*: None</p> <p>*: None</p> <p>P: Expansion PAPER sensor P: Paper set -: No paper</p> <p>U: Expansion Pickup sensor U: Paper detect -: No paper</p>
<p>D: Document D: Document set -: No document</p> <p>S: Read position S: Document detect -: No document</p> <p>C: Front cover C: Cover open -: Cover close</p> <p>P: Standard cassette recording paper P: Paper detect -: No paper</p> <p>R: Registration R: Paper detect -: No paper</p> <p>E: Paper exit E: Paper detect -: No paper</p> <p>*: None</p> <p>T: Toner T: Toner detect -: No toner</p> <p>K: Toner Cartridge contact K: Contact -: No contact</p> <p>N: First use Toner Cartridge N: New -: Secondhand</p> <p>B: Rear cover B: Cover open -: Cover close</p> <p>*: None</p> <p>3F: Fuser thermistor 3F: 00 (high temp.) - FF (low temp.)</p> <p>DF: Room thermistor DF: 00 (high temp.) - FF (low temp.)</p>	<p>C: Cassette open and close C: Cassette open -: Cassette close</p> <p>U: Pickup U: Paper detect -: No paper</p> <p>T: Print timing T: Paper detect -: No paper</p> <p>*: None</p> <p>*: None</p> <p>*: None</p> <p>D: ADF Duplex D: Document detect -: No document</p> <p>M: MPT paper M: Paper set -: No paper</p> <p>A: ADU A: Paper detect -: No paper</p> <p>N: First use drum sensor N: New -: Secondhand</p> <p>C: Drum contact sensor C: Contact -: No contact</p> <p>*: None</p> <p>*: None</p> <p>*: None</p> <p>P: Expansion PAPER sensor P: Paper set -: No paper</p> <p>U: Expansion Pickup sensor U: Paper detect -: No paper</p>				

Note:

The numbers in the boxes (XXX) indicate the keys to be input for the various test modes.

10.1.1. DTMF Single Tone Transmit Selection

When set to ON (=1), the 12 keys and transmission frequencies are as shown.

key	Low Frequency (Hz)	Key	High Frequency (Hz)
"1"	697	"5"	1209
"2"	770	"6"	1336
"3"	852	"7"	1477
"4"	941	"8"	1633

When set to OFF (=2), the 12 keys and transmission frequencies are as shown.

	High (Hz)	1209	1336	1477
Low (Hz)				
697	"1"	"2"	"3"	
770	"4"	"5"	"6"	
852	"7"	"8"	"9"	
941	"X"	"0"	"#"	

Note:

After performing this check, do not forget to turn the setting off. otherwise, dialing in DTMF signal will not work.

10.1.2. Button Code Table (KX-MB2230/KX-MB2545 ONLY)

Code	Button Name	Code	Button Name	Code	Button Name
31	1	40	SET	62	SCAN MODE
32	2	44	MENU	61	COPY MODE
33	3	51	FAX AUTO ANSWER	60	FAX MODE
34	4	66	NAVIGATOR ←	8F	ECO MODE
35	5	65	NAVIGATOR →	8B	DUPLEX
36	6	46	NAVIGATOR ↑		
37	7	47	NAVIGATOR ↓		
38	8	8C	COPY SIZE		
39	9	5F	ZOOM		
30	0	52	PAGE LAYOUT		
3B	✕	6E	QUALLITY		
3C	#		(Contrast/Resolution)		
54	MONITOR				
41	START				
-	STOP				

10.1.3. Button Code Table (KX-MB2270/KX-MB2575 ONLY)

Code	Button Name	Code	Button Name	Code	Button Name
31	1	40	SET	62	SCAN MODE
32	2	44	MENU	61	COPY MODE
33	3	51	FAX AUTO ANSWER	60	FAX MODE
34	4	66	NAVIGATOR ←	8E	WPS
35	5	65	NAVIGATOR →	8F	ECO MODE
36	6	46	NAVIGATOR ↑	8B	DUPLEX
37	7	47	NAVIGATOR ↓		
38	8	8C	COPY SIZE		
39	9	5F	ZOOM		
30	0	52	PAGE LAYOUT		
3B	✕	6E	QUALLITY		
3C	#		(Contrast/Resolution)		
54	MONITOR				
41	START				
-	STOP				

10.1.4. Button Code Table (KX-MB2515 ONLY)

Code	Button Name	Code	Button Name	Code	Button Name
31	1	40	SET	62	SCAN MODE
32	2	44	MENU	61	COPY MODE
33	3	66	NAVIGATOR ←	8F	ECO MODE
34	4	65	NAVIGATOR →	8B	DUPLEX
35	5	46	NAVIGATOR ↑		
36	6	47	NAVIGATOR ↓		
37	7	8C	COPY SIZE		
38	8	5F	ZOOM		
39	9	52	PAGE LAYOUT		
30	0	6E	QUALITY (Contrast/Resolution)		
3B	✳				
3C	#				
41	START				
-	STOP				

10.1.5. Button Code Table (DP-MB310 ONLY)

Code	Button Name	Code	Button Name	Code	Button Name
31	1	40	SET	67	LOWER
32	2	44	MENU	62	SCAN MODE
33	3	51	FAX AUTO ANSWER	61	COPY MODE
34	4	66	NAVIGATOR ←	60	FAX MODE
35	5	65	NAVIGATOR →	8F	ECO MODE
36	6	46	NAVIGATOR ↑	8B	DUPLEX
37	7	47	NAVIGATOR ↓		
38	8	8C	COPY SIZE		
39	9	5F	ZOOM		
30	0	52	PAGE LAYOUT		
3B	✳	6E	QUALITY (Contrast/Resolution)		
3C	#				
54	MONITOR	48	STATION 1		
41	START	49	STATION 2		
-	STOP	4A	STATION 3		

10.1.6. Print Test Pattern

1. NO.01

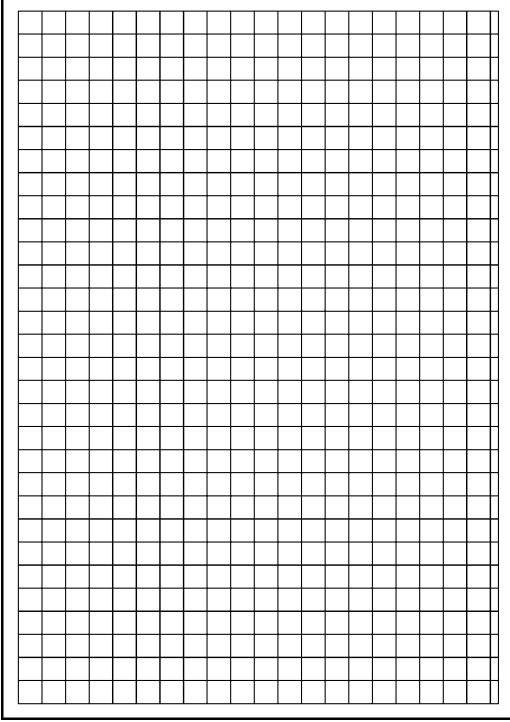

2. NO.06

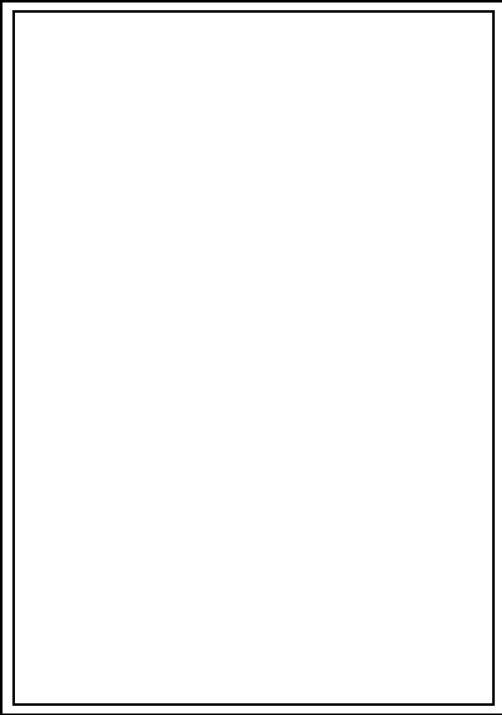

3. NO.03

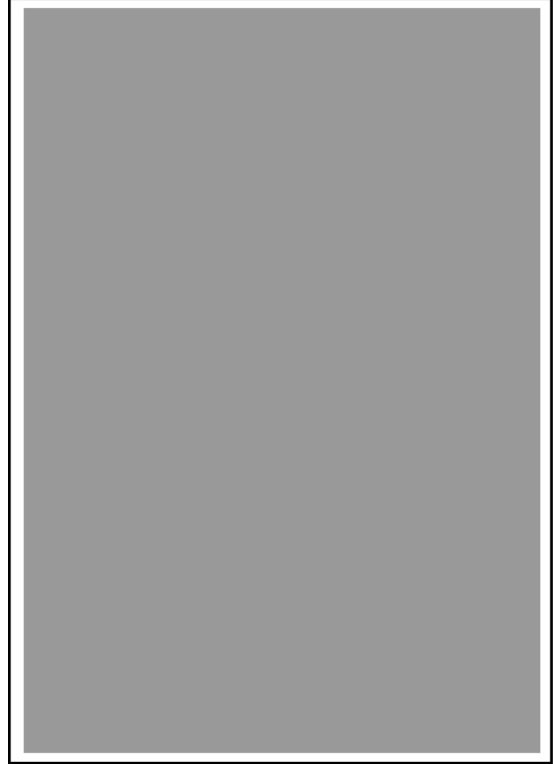

- These print test patterns are just image printing, and different from actual ones.
- When it is required to judge the print quality, compare with the printing of a nondefective machine.

11 Service Mode

The programming functions are used to program the various features and functions of the machine, and to test the machine. This facilitates communication between the user and the service man while programming the unit.

11.1. Programming and Lists

11.1.1. Operation

There are 2 basic categories of programming functions, the User Mode and the Service Mode. The Service Mode is further broken down into the normal and special programs. The normal programs are those listed in the Operating Instructions and are available to the user. The special programs are only those listed here and not displayed to the user. In both the User and Service Modes, there are Set Functions and Test Functions. The Set Functions are used to program various features and functions, and the Test Functions are used to test the various functions. The Set Functions are accessed by entering their code, changing the appropriate value, then pressing the SET key. The Test Functions are accessed by entering their code and pressing the key listed on the menu. While programming, to cancel any entry, press the STOP key.

Note:

When changing the set values on the service function table, they should not be set beyond the local regulation. Follow the laws and regulations of your area.

11.1.2. Operation Flow

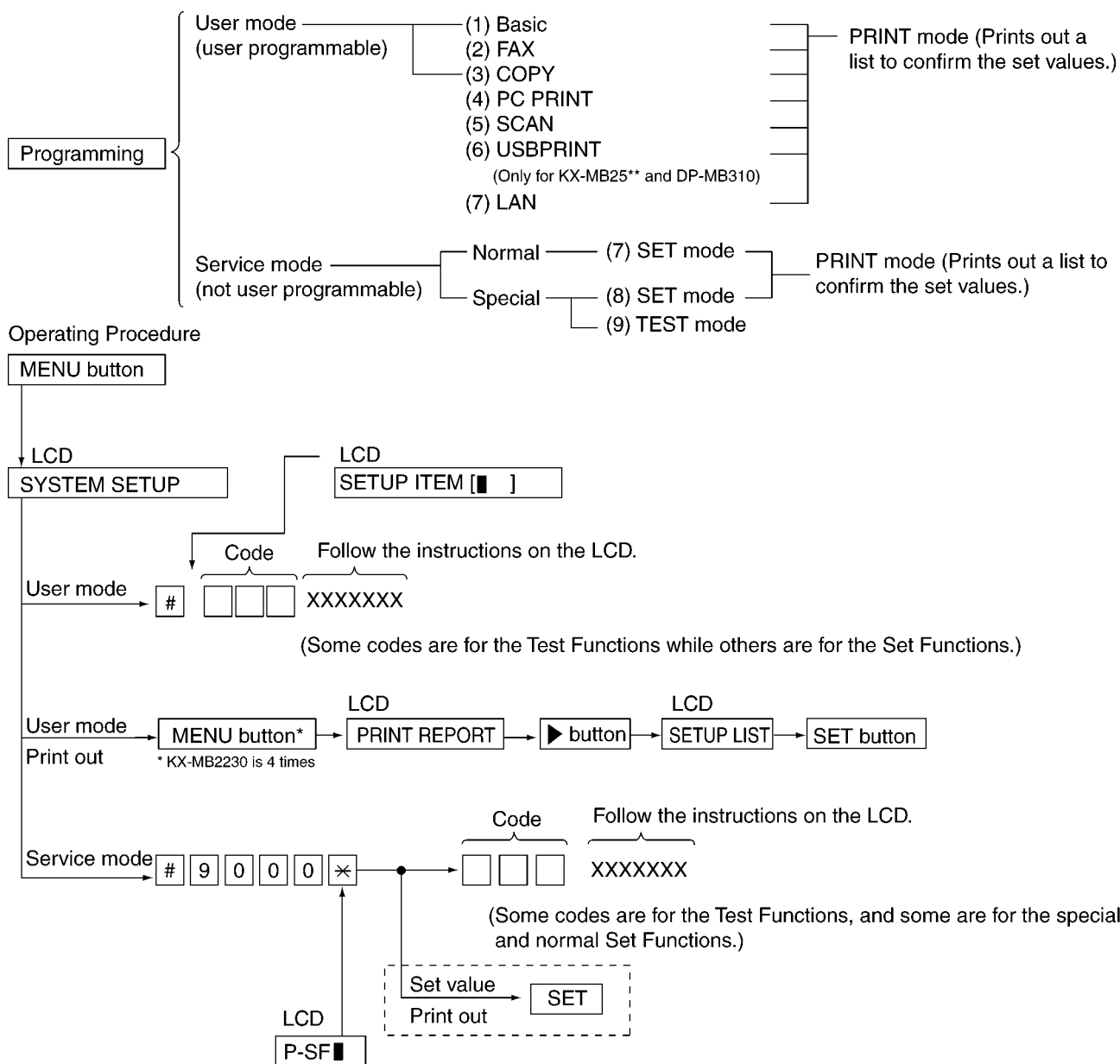

11.1.3. Service Function Table

Code	Function	Set Value	Effective Range	Default	Remarks
529	Call Service Clear				
550	Memory clear				Refer to Memory Clear Specification (P.145).
551	ROM check				See Test Functions (P.136).
555	Scanner test				See Test Functions (P.136).
556	Motor test			0	See Test Functions (P.136).
557	LED test				See Test Functions (P.136).
558	LCD test				See Test Functions (P.136).
561	KEY test				See Test Functions (P.136).
628	H.V.P.S. check				See Test Functions (P.136).
639	LSU test				See Test Functions (P.136).
655	Cause Distinction Code of Call Service 3				See CALL SERVICE Troubleshooting Guide (P.188).
677	FAN test				See Test Functions (P.136).
710	Memory clear except History data				Refer to Memory Clear Specification (P.145).
796	Attach sending image to sending report	1: ON 2: OFF	1, 2	1	
815	Sensor check				See Test Functions (P.136).
852	Print test pattern				See Test Functions (P.136).
853	Top margin	X 0.5mm	01~11	06	-----
854	Left margin	X 0.5mm	01~11	06	-----
856	Top margin (DUPLEX)	X 0.5mm	01~11	06	-----
870	Left margin (OPF)	X 0.5mm	01~11	06	Only for KX-MB25** and DP-MB310
871	Left margin (DUPLEX)	X 0.5mm	01~11	06	-----
880	History list				See History (Example of a printed out list) (P.164).
881	Journal 2 list				See Journal 2 (P.221).
882	Journal 3 list				See Journal 3 (P.222).

11.1.4. Service Function Table (Fax supported models only)

Code	Function	Set Value	Effective Range	Default	Remarks
501	Pause time set	X 100msec	001~600	030	-----
503	Dial speed select	1: 10pps 2: 20pps	1, 2	1	-----
507	V34 transmission start speed	0: Disable 1: 33.6 2: 31.2 3: 28.8 4: 26.4 5: 24.0 6: 21.6 7: 19.2 8: 16.8	0~8	1	If the code 527 is set at 2, the code 507 and 508 work.
508	V34 reception start speed	0: Disable 1: 33.6 2: 31.2 3: 28.8 4: 26.4 5: 24.0 6: 21.6 7: 19.2 8: 16.8	0~8	1	If the code 527 is set at 2, the code 507 and 508 work.
514	Bell signal detect time	X 100msec	1~9	3	-----
520	CED frequency select	1: 2,100Hz 2: 1,100Hz	1, 2	1	See How To Output The Journal Report (P.224).
521	International mode select	1: ON 2: OFF	1, 2	1	See How To Output The Journal Report (P.224).
522	Auto standby select	1: ON 2: OFF	1, 2	1	The resolution reverts to the default when transmission is complete.
523	Receive equalizer select	1: 0km 2: 1.8km 3: 3.6km 4: 7.2km	1~4	1	Set RX equalizer to automatic mode.
524	Transmission equalizer select	1: 0km 2: 1.8km 3: 3.6km 4: 7.2km	1~4	1	
527	V.8 function select	1: OFF 2: ON	1, 2	2	
552	DTMF signal tone test	1: ON 2: OFF	1, 2	2	See Test Functions (P.136).
553	Monitor on FAX communication select	1: OFF 2: Phase B 3: ALL	1~3	1	Sets whether to monitor the line signal with the unit's speaker during FAX communication or not.
554	Modem test				See Test Functions (P.136).
565	Irregular data set	1: Non-Delete 2: Delete	1,2	1	Sets whether delete Caller ID irregular data or not .
567	T0 timer	X sec	001~255	052	Sets a higher value when the response from the other party needs more time during automatic FAX transmission.
570	BREAK% select	1: 61% 2: 67% 3: 63%	1, 2, 3	1	Sets the% break of pulse dialing according PBX.
573	Remote turn-on ring number set	X number of rings	00~99	10	Sets the number of rings before the unit starts to operate TAM in the TEL mode.
574	Dial tone detect check	1: ON 2: OFF	1, 2	2	-----
590	FAX auto redial time set	X number of times	00~99	05	Selects the number of redial times during FAX communication (not including the first dial).
591	FAX auto redial line disconnection time set	X sec	001~999	065	Sets the FAX redial interval during FAX communication.
592	CNG transmit select	1: OFF 2: ALL 3: AUTO	1~3	2	Lets you select the CNG output during FAX transmission. ALL: CNG is output at phase A. AUTO: CNG is output only when automatic dialing is performed. OFF: CNG is not output at phase A. Refer to Sometime There is a Transmit Problem (P.217).

Code	Function	Set Value	Effective Range	Default	Remarks
593	Time between CED and 300bps	1: 75msec 2: 500msec 3: 1sec	1~3	1	See How To Output The Journal Report (P.224) and Receive Problem (P.218) .
594	Overseas DIS detection select	1: detects at the 1st time 2: detects at the 2nd time	1, 2	1	See How To Output The Journal Report (P.224) and Sometime There is a Transmit Problem (P.217) .
595	Receive error limit value set	1: 5% 2: 10% 3: 15% 4: 20%	1~4	2	If the number of errors during transmission exceeds this value, the sending side terminates the call.
596	Transmit level set	X dBm	-15~00	10	Selects the FAX transmission level. Refer to Sometime There is a Transmit Problem (P.217) and Receive Problem (P.218) .
598	Receiving sensitivity	43= -43dBm	20~48	48	Used when there is an error problem. Refer to How To Output The Journal Report (P.224) .
599	ECM frame size	1: 256 2: 64	1, 2	1	-----
711	Dialing mode	1: PULSE 2: TONE	1,2	2	
717	Transmit speed select	1: 14,400bps 2: 12,000bps 3: 9,600bps 4: 7,200bps 5: 4,800bps 6: 2,400bps	1~6	1	If the code 527 is set at 1, the code 717 and 718 work.
718	Receive speed select	1: 14,400bps 2: 12,000bps 3: 9,600bps 4: 7,200bps 5: 4,800bps 6: 2,400bps	1~6	1	If the code 527 is set at 1, the code 717 and 718 work.
721	Pause tone detect	1: ON 2: OFF	1, 2	2	Selects the tone detection for pause in dialing.
722	Redial tone detect	1: ON 2: OFF	1, 2	1	Sets the tone detection mode after redialing.
763	CNG detect time for friendly reception	1: 10sec 2: 20sec 3: 30sec	1~3	3	Selects the CNG detection tone of friendly reception.
774	Receiving T4 timer	X 100msec	00~99	00	Use this function when delay occurs in the line and communication. (ex. Mobile comm) does not work well.
775	Transmission T4 timer	X 100msec	00~99	00	Use this function when delay occurs in the line and communication. (ex. Mobile comm) does not work well.
874	DTMF ON time	X msec	060~200	100	-----
875	DTMF OFF time	X msec	060~200	100	-----
529	Call Service Clear				
550	Memory clear				Refer to Memory Clear Specification (P.145) .
551	ROM check				See Test Functions (P.136) .
555	Scanner test				See Test Functions (P.136) .
556	Motor test			0	See Test Functions (P.136) .
557	LED test				See Test Functions (P.136) .
558	LCD test				See Test Functions (P.136) .
561	KEY test				See Test Functions (P.136) .
628	H.V.P.S. check				See Test Functions (P.136) .
639	LSU test				See Test Functions (P.136) .
655	Cause Distinction Code of Call Service 3				See CALL SERVICE Troubleshooting Guide (P.188) .
677	FAN test				See Test Functions (P.136) .
710	Memory clear except History data				Refer to Memory Clear Specification (P.145) .
796	Attach sending image to sending report	1: ON 2: OFF	1, 2	1	
815	Sensor check				See Test Functions (P.136) .
852	Print test pattern				See Test Functions (P.136) .
853	Top margin	X 0.5mm	01~11	06	-----
854	Left margin	X 0.5mm	01~11	06	-----
856	Top margin (DUPLEX)	X 0.5mm	01~11	06	-----
870	Left margin (OPF)	X 0.5mm	01~11	06	Only for KX-MB25** and DP-MB310

Code	Function	Set Value	Effective Range	Default	Remarks
871	Left margin (DUPLEX)	X 0.5mm	01~11	06	-----
880	History list				See History (Example of a printed out list) (P.164).
881	Journal 2 list				See Journal 2 (P.221).
882	Journal 3 list				See Journal 3 (P.222).

11.1.5. Memory Clear Specification

Item	Status after Memory Clear	
	Service Mode #550 ^{*1}	Service Mode #710 ^{*2}
Date and time (user mode #101)	—	Default
Your logo (user mode #102)	—	Default
Your Fax Number (user mode #103)	—	Default
Password (user mode #155)	—	Default
One touch dial and Directory	—	Default
History	—	—
Top margin (service mode #853)	—	—
Left margin (service mode #854)	—	—
Other Setting data (User setting and Service setting data)	Default	Default

— : Not changed

*1 Execute Service Mode #550 when you want to reset the all setting data keeping the user information.

*2 Execute Service Mode #710 to clear the user information in case that Main Unit is recycled.

Note:

Please restart a power supply after clearing a memory.

11.2. User Mode (The list below is an example of the SYSTEM SETUP LIST the unit prints out.)

(KX-MB2230)

SETUP LIST

[BASIC FEATURE LIST]

NO.	FEATURE	CURRENT SETTING
#101	SET DATE & TIME	05 Feb. 2013 04:20
#102	YOUR LOGO	
#103	YOUR FAX NUMBER	
#110	LANGUAGE	ENGLISH [ENGLISH, CZECH, FRENCH, GERMAN, HUNGARIAN, POLISH, PORTUGUESE, SLOVAK, SPANISH, TURKISH]
#114	LOCATION	GERMANY [BELGIUM, CZECH, EUR. STNDARD, FRANCE, GERMANY, HUNGARY, NETHERLANDS, POLAND, PORTUGAL, SLOVAKIA, SPAIN, U.K.]
#120	DIALLING MODE	TONE [TONE, PULSE]
#121	SET FLASH TIME	100ms [900, 700, 600, 400, 300, 250, 200, 160, 110, 100, 90, 80(ms)]
#124	ADSL MODE	OFF [OFF, ON]
#145	LCD CONTRAST	NORMAL [NORMAL, DARKER]
#147	SCALE	MILLIMETRES [MILLIMETRES, INCHES]
#148	DISPLAY INTERVAL	1sec [1sec, 2sec, 3sec, 4sec, 5sec]
#151	ADMIN CODE	
#154	MODE RESTRICTION	OFF [OFF, ON]
#155	CHANGE PASSWORD	
#158	MAINTENANCE TIME	00:00
#159	RESTORE DEFAULT	
#161	RINGER PATTERN	A [A, B, C]
#165	BEEP SOUND	ON [OFF, ON]
#174	JOB END NOTIFY	OFF [OFF, ON]
#210	FAX RING COUNT	2 [1...9]
#289	ERASE ADDR. BOOK	
#380	PAPER SIZE #1	A4 [LETTER, A4, LEGAL, B5 (ISO), B5 (JIS), 16K, 216x330, 216x340, A5]
#381	PAPER SIZE #2	A4 [LETTER, A4, LEGAL, B5 (ISO), B5 (JIS), 16K, 216x330, 216x340, A5, A6, B6 (ISO), B6 (JIS)]
#383	MEDIA TYPE #1	PLAIN PAPER [PLAIN PAPER, THIN PAPER]
#384	MEDIA TYPE #2	PLAIN PAPER [PLAIN PAPER, THIN PAPER, THICK PAPER]
#403	POWER SAVE	1min [1min, 5min, 15min, 30min, 45min]
#462	CONTRAST HOLD	DISABLED [DISABLED, ENABLED]
#463	DEFAULT MODE	COPY [COPY, FAX]
#464	MODE TIMER	1min [OFF, 30s, 1min, 2min, 5min]
#479	DEPT. COUNT VIEW	
#482	TONER SAVE	OFF Set Value [OFF, ON]

Code

Code

[COPY FEATURE LIST]

NO.	FEATURE	CURRENT SETTING
#460	COPY INPUT TRAY	#1 [#1, #2]
#461	COPY RESOLUTION	TEXT/PHOTO [TEXT/PHOTO, TEXT, PHOTO]
#467	PAGE LAYOUT HOLD	DISABLED [DISABLED, ENABLED]
#468	ZOOM HOLD	DISABLED [DISABLED, ENABLED]
#469	COLLATE HOLD	DISABLED [DISABLED, ENABLED]
#470	DUPLEX HOLD	DISABLED [DISABLED, ENABLED]
#473	EDGE HOLD	DISABLED [DISABLED, ENABLED]
#474	FRAME MARGIN	DISABLED [DISABLED, ENABLED]
#475	MARGIN HOLD	DISABLED [DISABLED, ENABLED]

Set Value

[PC PRINT FEATURE LIST]

NO.	FEATURE	CURRENT SETTING
#774	DATA TIMEOUT	60s [5...600(s)]
#776	MUTUAL A4/LETTER	ON [OFF, ON]

[SCAN FEATURE LIST]

NO.	FEATURE	CURRENT SETTING
#493	SCAN MODE	VIEWER [VIEWER, FILE, EMAIL, OCR]
#494	SCAN PARAM. HOLD	DISABLED [DISABLED, ENABLED]

[FAX FEATURE LIST]

NO.	FEATURE	CURRENT SETTING
#212	TEL/FAX DELAYED RING	2 [1...9]
#319	REMOTE TURN ON	OFF [OFF, ON]
#401	PRINT SENDING REPORT	ERROR [OFF, ON, ERROR]
#402	JOURNAL AUTO PRINT	ON [OFF, ON]
#404	MANUAL ANSWER MODE	TEL [TEL, TEL/FAX]
#405	FAX RESOLUTION	STANDARD [STANDARD, FINE, SUPER FINE, PHOTO]
#407	FAX DUPLEX PRINT	OFF [OFF, LONG EDGE, SHORT EDGE]
#411	OVERSEAS MODE	ERROR [NEXT FAX, ERROR, OFF]
#412	DELAYED TRANSMISSION	OFF [OFF, ON]
	DESTINATION =	
	START TIME = 00:00	
#413	ECM SELECTION	ON [OFF, ON]
#416	CONNECTING TONE	ON [OFF, ON]
#418	MAX FAX SPEED	33.6kbps [33.6kbps, 14.4kbps]
#419	QUICK SCAN MODE	OFF [OFF, ALWAYS]
#420	CONFIRM FAX NO.	OFF [OFF, ON]
#421	RESTRICT FAX NO.	OFF [OFF, ON]
#422	RE-ENTER FAX NO.	OFF [OFF, ON]
#424	CONFIRM NEXT DOC	OFF [OFF, ON]
#432	AUTO REDUCTION	ON [OFF, ON]
#434	FAX ACTIVATION CODE	ON [OFF, ON]
	CODE = *#9	
#436	SILENT FAX RECOGNITION RING	3 [3...9]
#437	MEMORY RECEIVE ALERT	ON [OFF, ON]
#438	FRIENDLY RECEPTION	ON [OFF, ON]
#442	PCFAX SETTING	CONNECTED [OFF, ALWAYS, CONNECTED]
#443	PCFAX RCV PC	USB HOST
#448	PREVIEW MODE	ON [OFF, ON]
#450	WEB FAX PREVIEW	
#451	RECEIVE NOTIFY	OFF [OFF, ON]
#452	FAX AUTO EMAIL	OFF [OFF, ON]
#458	ERASE FAX MEMORY	
#459	SET FAX DEFAULT	

Code

Set Value

[LAN FEATURE LIST]

NO.	FEATURE	CURRENT SETTING
#500	DHCP	ENABLED [DISABLED, ENABLED]
#501	IP ADDRESS	10.178.15.105
#502	SUBNET MASK	255.255.254.0
#503	DEFAULT GATEWAY	10.178.14.1
#504	DNS SERVER #1	10.75.17.165
#505	DNS SERVER #2	133.185.137.47
#507	MACHINE NAME	MB2230-F00E79B5
#508	MAC ADDRESS	00:80:F0:0E:79:B5
#513	BONJOUR	ENABLED [DISABLED, ENABLED]
#526	NETWORK STATUS	
#532	IP FILTERING	DISABLED [DISABLED, ENABLED]
#533	AUTO IP	DISABLED [DISABLED, ENABLED]
#534	HTTPD	ENABLED [DISABLED, ENABLED]
#535	IPv6 PROTOCOL	DISABLED [DISABLED, ENABLED]
#538	WINS SERVER #1	10.75.17.165
#539	WINS SERVER #2	133.185.137.47
#567	ADDRESS ON WEB	ENABLED [DISABLED, ENABLED]
#569	JOURNAL ON WEB	ENABLED [DISABLED, ENABLED]
#578	ERASE ADDRESS	
#580	LAN MODE	WIRED [OFF, WIRED]
	FIRMWARE VERSION	GFJ1GB

Code

Set Value

(KX-MB2270)

SETUP LIST

[BASIC FEATURE LIST]

NO.	FEATURE	CURRENT SETTING	
#101	SET DATE & TIME	01 Jan. 2013 00:00	
#102	YOUR LOGO		
#103	YOUR FAX NUMBER		
#110	LANGUAGE	ENGLISH	[ENGLISH, CZECH, FRENCH, GERMAN, HUNGARIAN, POLISH, PORTUGUESE, SLOVAK, SPANISH, TURKISH]
#114	LOCATION	GERMANY	[BELGIUM, CZECH, EUR. STANDARD, FRANCE, GERMANY, HUNGARY, NETHERLANDS, POLAND, PORTUGAL, SLOVAKIA, SPAIN, U.K.]
#120	DIALLING MODE	TONE	[TONE, PULSE]
#121	SET FLASH TIME	100ms	[900, 700, 600, 400, 300, 250, 200, 160, 110, 100, 90, 80 (ms)]
#124	ADSL MODE	OFF	[OFF, ON]
#145	LCD CONTRAST	NORMAL	[NORMAL, DARKER]
#147	SCALE	MILLIMETRES	[MILLIMETRES, INCHES]
Code #148	DISPLAY INTERVAL	1sec	[1sec, 2sec, 3sec, 4sec, 5sec]
#151	ADMIN CODE		
#154	MODE RESTRICTION	OFF	[OFF, ON]
#155	CHANGE PASSWORD		
#158	MAINTENANCE TIME	00:00	
#159	RESTORE DEFAULT		
#161	RINGER PATTERN	A	[A, B, C]
#165	BEEP SOUND	ON	[OFF, ON]
#174	JOB END NOTIFY	OFF	[OFF, ON]
#210	FAX RING COUNT	2	[1...9]
#289	ERASE ADDR. BOOK		
Code #380	PAPER SIZE #1	A4	[LETTER, A4, LEGAL, B5 (ISO), B5 (JIS), 16K, 216X330, 216X340, A5]
Code #381	PAPER SIZE #2	A4	[LETTER, A4, LEGAL, B5 (ISO), B5 (JIS), 16K, 216X330, 216X340, A5, A6, B6 (ISO), B6 (JIS)]
#383	MEDIA TYPE #1	PLAIN PAPER	[PLAIN PAPER, THIN PAPER]
#384	MEDIA TYPE #2	PLAIN PAPER	[PLAIN PAPER, THIN PAPER, THICK PAPER]
#403	POWER SAVE	1min	[1min, 5min, 15min, 30min, 45min]
#462	CONTRAST HOLD	DISABLED	[DISABLED, ENABLED]
#463	DEFAULT MODE	COPY	[COPY, FAX]
#464	MODE TIMER	1min	[OFF, 30s, 1min, 2min, 5min]
#479	DEPT. COUNT VIEW		
#482	TONER SAVE	OFF	Set Value [OFF, ON]

[COPY FEATURE LIST]

NO.	FEATURE	CURRENT SETTING	
#460	COPY INPUT TRAY	#1	[#1, #2]
#461	COPY RESOLUTION	TEXT/PHOTO	[TEXT/PHOTO, TEXT, PHOTO]
#467	PAGE LAYOUT HOLD	DISABLED	[DISABLED, ENABLED]
#468	ZOOM HOLD	DISABLED	[DISABLED, ENABLED]
#469	COLLATE HOLD	DISABLED	[DISABLED, ENABLED]
#470	DUPLEX HOLD	DISABLED	[DISABLED, ENABLED]
#473	EDGE HOLD	DISABLED	[DISABLED, ENABLED]
#474	FRAME MARGIN	DISABLED	[DISABLED, ENABLED]
#475	MARGIN HOLD	DISABLED	[DISABLED, ENABLED]

[PC PRINT FEATURE LIST]

NO.	FEATURE	CURRENT SETTING	
#774	DATA TIMEOUT	60s	[5...600 (s)]
#776	MUTUAL A4/LETTER	ON	[OFF, ON]

[SCAN FEATURE LIST]

NO.	FEATURE	CURRENT SETTING	
#493	SCAN MODE	VIEWER	[VIEWER, FILE, EMAIL, OCR]
#494	SCAN PARAM. HOLD	DISABLED	[DISABLED, ENABLED]

[FAX FEATURE LIST]

NO.	FEATURE	CURRENT SETTING
#212	TEL/FAX DELAYED RING	2 [1..9]
#319	REMOTE TURN ON	ON [OFF, ON]
#401	PRINT SENDING REPORT	ERROR [OFF, ON, ERROR]
#402	JOURNAL AUTO PRINT	ON [OFF, ON]
#404	MANUAL ANSWER MODE	TEL [TEL, TEL/FAX]
#405	FAX RESOLUTION	STANDARD [STANDARD, FINE, SUPER FINE, PHOTO]
#407	FAX DUPLEX PRINT	OFF [OFF, LONG EDGE, SHORT EDGE]
#411	OVERSEAS MODE	ERROR [NEXT FAX, ERROR, OFF]
#412	DELAYED TRANSMISSION	OFF [OFF, ON]
DESTINATION =		
START TIME = 00:00		
#413	ECM SELECTION	ON [OFF, ON]
#416	CONNECTING TONE	ON [OFF, ON]
#418	MAX FAX SPEED	33.6kbps [33.6kbps, 14.4kbps]
#419	QUICK SCAN MODE	OFF [OFF, ALWAYS]
#420	CONFIRM FAX NO.	OFF [OFF, ON]
#421	RESTRICT FAX NO.	OFF [OFF, ON]
#422	RE-ENTER FAX NO.	OFF [OFF, ON]
#424	CONFIRM NEXT DOC	OFF [OFF, ON]
#432	AUTO REDUCTION	ON [OFF, ON]
#434	FAX ACTIVATION CODE	ON [OFF, ON]
CODE = *#9		
#436	SILENT FAX RECOGNITION RING	3 [3..9]
#437	MEMORY RECEIVE ALERT	ON [OFF, ON]
#438	FRIENDLY RECEPTION	ON [OFF, ON]
#442	PCFAX SETTING	CONNECTED [OFF, ALWAYS, CONNECTED]
#443	PCFAX RCV PC	USB HOST
#448	PREVIEW MODE	OFF [OFF, ON]
#450	WEB FAX PREVIEW	
#451	RECEIVE NOTIFY	OFF [OFF, ON]
#452	FAX AUTO EMAIL	OFF [OFF, ON]
#458	ERASE FAX MEMORY	
#459	SET FAX DEFAULT	

[LAN FEATURE LIST]

NO.	FEATURE	CURRENT SETTING
#500	DHCP	ENABLED [DISABLED, ENABLED]
#501	IP ADDRESS	10.178.15.105
#502	SUBNET MASK	255.255.254.0
#503	DEFAULT GATEWAY	10.178.14.1
#504	DNS SERVER #1	10.75.17.165
#505	DNS SERVER #2	133.185.137.47
#507	MACHINE NAME	MB2270-F00E79B5
#508	MAC ADDRESS	00:80:F0:0E:79:B5
#513	BONJOUR	ENABLED [DISABLED, ENABLED]
#526	NETWORK STATUS	
#532	IP FILTERING	DISABLED [DISABLED, ENABLED]
#533	AUTO IP	DISABLED [DISABLED, ENABLED]
#534	HTTPD	ENABLED [DISABLED, ENABLED]
#535	IPv6 PROTOCOL	DISABLED [DISABLED, ENABLED]
#538	WINS SERVER #1	10.75.17.165
#539	WINS SERVER #2	133.185.137.47
#567	ADDRESS ON WEB	ENABLED [DISABLED, ENABLED]
#569	JOURNAL ON WEB	ENABLED [DISABLED, ENABLED]
#578	ERASE ADDRESS	
#580	LAN MODE	WIRED [OFF, WIRED, WIRELESS]
#581	WIRELESS STATUS	
#582	WPS-PBC	
#583	WPS-PIN	
#584	SSID SEARCH	
#585	CONFIGURATION	
#586	WIRELESS RESTORE	
	FIRMWARE VERSION	GG21GA

(KX-MB2515)

SETUP LIST

[BASIC FEATURE LIST]

NO.	FEATURE	CURRENT SETTING
#101	SET DATE & TIME	01 Jan. 2013 00:00
#110	LANGUAGE	ENGLISH [ENGLISH, CZECH, FRENCH, GERMAN, HUNGARIAN, POLISH, PORTUGUESE, SLOVAK, SPANISH, TURKISH]
#114	LOCATION	GERMANY [BELGIUM, CZECH, EUR.STANDARD, FRANCE, GERMANY, HUNGARY, NETHERLANDS, POLAND, PORTUGAL, SLOVAKIA, SPAIN, U.K.]
#145	LCD CONTRAST	0 [-2, -1, 0, 1, 2]
#147	SCALE	MILLIMETRES [MILLIMETRES, INCHES]
#148	DISPLAY INTERVAL	1sec [1sec, 2sec, 3sec, 4sec, 5sec]
#151	ADMIN CODE	
#154	MODE RESTRICTION	OFF [OFF, ON]
#155	CHANGE PASSWORD	
#158	MAINTENANCE TIME	00:00
#159	RESTORE DEFAULT	
#165	BEEP SOUND	ON [OFF, ON]
#289	ERASE ADDR. BOOK	
#380	PAPER SIZE #1	A4 [LETTER, A4, LEGAL, B5 (ISO), B5 (JIS), 16K, 216X330, 216X340, A5]
#381	PAPER SIZE #2	A4 [LETTER, A4, LEGAL, B5 (ISO), B5 (JIS), 16K, 216X330, 216X340, A5, A6, B6 (ISO), B6 (JIS)]
#383	MEDIA TYPE #1	PLAIN PAPER [PLAIN PAPER, THIN PAPER]
#384	MEDIA TYPE #2	PLAIN PAPER [PLAIN PAPER, THIN PAPER, THICK PAPER]
#403	POWER SAVE	1min [1min, 5min, 15min, 30min, 45min]
#462	CONTRAST HOLD	DISABLED [DISABLED, ENABLED]
#479	DEPT. COUNT VIEW	
#482	TONER SAVE	OFF [OFF, ON]

Code

Code

Set Value

[COPY FEATURE LIST]

NO.	FEATURE	CURRENT SETTING
#460	COPY INPUT TRAY	#1 [#1, #2, #3, #1+#2, #1+#3, #2+#3, #1+#2+#3]
#461	COPY RESOLUTION	TEXT/PHOTO [TEXT/PHOTO, TEXT, PHOTO]
#467	PAGE LAYOUT HOLD	DISABLED [DISABLED, ENABLED]
#468	ZOOM HOLD	DISABLED [DISABLED, ENABLED]
#469	COLLATE HOLD	DISABLED [DISABLED, ENABLED]
#470	DUPLEX HOLD	DISABLED [DISABLED, ENABLED]
#473	EDGE HOLD	DISABLED [DISABLED, ENABLED]
#474	FRAME MARGIN	DISABLED [DISABLED, ENABLED]
#475	MARGIN HOLD	DISABLED [DISABLED, ENABLED]

Set Value

[SCAN FEATURE LIST]

NO.	FEATURE	CURRENT SETTING
#493	SCAN MODE	VIEWER [VIEWER, FILE, EMAIL, OCR]
#494	SCAN PARAM. HOLD	DISABLED [DISABLED, ENABLED]

[PC PRINT FEATURE LIST]

NO.	FEATURE	CURRENT	SETTING
#760	PCL PAPER SOURCE	#1	[#1,#2,#3,#1+#2,#1+#3,#2+#3,#1+#2+#3]
#762	PCL COPIES	1	[1...999]
#763	PRINT FORMAT	A4	[LETTER,A4,LEGAL,B5(ISO),B5(JIS),16K,216X330,216X340,A5,A6,B6(ISO),B6(JIS)]
#764	IMAGE REDUCTION	ON	[OFF,ON]
#765	PCL ORIENTATION	PORTRAIT	[PORTRAIT,LANDSCAPE]
#766	A4 WIDE	OFF	[OFF,ON]
#767	LINES PER PAGE	64	[5...128]
#768	FONT SOURCE	RESIDENT	[RESIDENT,DOWNLOAD FONT]
#769	FONT NUMBER	0	[0...54]
#770	FONT PITCH/POINT	10.00	[0.44...99.99]
#771	SYMBOL SET	PC-8	
#772	CR/LF/FF	CR/LF/FF	[CR/LF/FF,CR+LF/LF/FF,CR/CR+LF/CR+FF]
#773	AUTO CONTINUE	OFF	[OFF,20s,30s,60s,90s,120s]
#774	DATA TIMEOUT	60s	[5...600(s)]
#776	MUTUAL A4/LETTER	ON	[OFF,ON]

Set Value

[USB PRINT FEATURE LIST]

NO.	FEATURE	CURRENT	SETTING
#660	COPIES	1	[1...99]
#661	ORIENTATION	PORTRAIT	[PORTRAIT,LANDSCAPE]
#662	N in 1	OFF	[OFF,2 in 1,4 in 1,8 in 1]
#663	Nin1 PAGE BORDER	NONE	[NONE,SOLID LINE]
#664	DUPLEX	OFF	[OFF,LONG EDGE,SHORT EDGE]
#665	CONTINUOUS PRINT	ENABLED	[DISABLED,ENABLED]
#669	INPUT TRAY	#1	[#1,#2,#3,#1+#2,#1+#3,#2+#3,#1+#2+#3]
#672	DISPLAY SORT	DATE ORDER	[OFF,NAME ORDER,DATE ORDER]

[LAN FEATURE LIST]

NO.	FEATURE	CURRENT	SETTING
#500	DHCP	ENABLED	[DISABLED,ENABLED]
#501	IP ADDRESS	0.0.0.0	
#502	SUBNET MASK	0.0.0.0	
#503	DEFAULT GATEWAY	0.0.0.0	
#504	DNS SERVER #1	0.0.0.0	
#505	DNS SERVER #2	0.0.0.0	
#507	MACHINE NAME	MB2515-2300FD5E	
#508	MAC ADDRESS	08:00:23:00:FD:5E	
#513	BONJOUR	ENABLED	[DISABLED,ENABLED]
#526	NETWORK STATUS		
#532	IP FILTERING	DISABLED	[DISABLED,ENABLED]
#533	AUTO IP	DISABLED	[DISABLED,ENABLED]
#534	HTTPD	ENABLED	[DISABLED,ENABLED]
#535	IPv6 PROTOCOL	DISABLED	[DISABLED,ENABLED]
#538	WINS SERVER #1	0.0.0.0	
#539	WINS SERVER #2	0.0.0.0	
#567	ADDRESS ON WEB	ENABLED	[DISABLED,ENABLED]
#578	ERASE ADDRESS		
#580	LAN MODE	WIRED	[OFF,WIRED]

Code

Code

Set Value

Set Value

FIRMWARE VERSION

GG51GA

(KX-MB2545)

SETUP LIST

[BASIC FEATURE LIST]

NO.	FEATURE	CURRENT SETTING
#101	SET DATE & TIME	01 Jan. 2013 00:00
#102	YOUR LOGO	
#103	YOUR FAX NUMBER	
#110	LANGUAGE	ENGLISH [ENGLISH, CZECH, FRENCH, GERMAN, HUNGARIAN, POLISH, PORTUGUESE, SLOVAK, SPANISH, TURKISH]
#114	LOCATION	GERMANY [BELGIUM, CZECH, EUR.STANDARD, FRANCE, GERMANY, HUNGARY, NETHERLANDS, POLAND, PORTUGAL, SLOVAKIA, SPAIN, U.K.]
#120	DIALLING MODE	TONE [TONE, PULSE]
#121	SET FLASH TIME	100ms [900, 700, 600, 400, 300, 250, 200, 160, 110, 100, 90, 80(ms)]
#124	ADSL MODE	OFF [OFF, ON]
#145	LCD CONTRAST	0 [-2, -1, 0, 1, 2]
#147	SCALE	MILLIMETRES [MILLIMETRES, INCHES]
#148	DISPLAY INTERVAL	1sec [1sec, 2sec, 3sec, 4sec, 5sec]
#151	ADMIN CODE	
#154	MODE RESTRICTION	OFF [OFF, ON]
#155	CHANGE PASSWORD	
#158	MAINTENANCE TIME	00:00
#159	RESTORE DEFAULT	
#161	RINGER PATTERN	A [A, B, C]
#165	BEEP SOUND	ON [OFF, ON]
#174	JOB END NOTIFY	OFF [OFF, ON]
#210	FAX RING COUNT	2 [1...9]
#289	ERASE ADDR. BOOK	
#380	PAPER SIZE #1	A4 [LETTER, A4, LEGAL, B5(ISO), B5(JIS), 16K, 216X330, 216X340, A5]
#381	PAPER SIZE #2	A4 [LETTER, A4, LEGAL, B5(ISO), B5(JIS), 16K, 216X330, 216X340, A5, A6, B6(ISO), B6(JIS)]
#383	MEDIA TYPE #1	PLAIN PAPER [PLAIN PAPER, THIN PAPER]
#384	MEDIA TYPE #2	PLAIN PAPER [PLAIN PAPER, THIN PAPER, THICK PAPER]
#403	POWER SAVE	1min [1min, 5min, 15min, 30min, 45min]
#462	CONTRAST HOLD	DISABLED [DISABLED, ENABLED]
#463	DEFAULT MODE	COPY [COPY, FAX]
#464	MODE TIMER	1min [OFF, 30s, 1min, 2min, 5min]
#479	DEPT. COUNT VIEW	
#482	TONER SAVE	OFF [OFF, ON]

Code

Code

Set Value

[COPY FEATURE LIST]

NO.	FEATURE	CURRENT SETTING
#460	COPY INPUT TRAY	#1 [#1, #2, #3, #1+#2, #1+#3, #2+#3, #1+#2+#3]
#461	COPY RESOLUTION	TEXT/PHOTO [TEXT/PHOTO, TEXT, PHOTO]
#467	PAGE LAYOUT HOLD	DISABLED [DISABLED, ENABLED]
#468	ZOOM HOLD	DISABLED [DISABLED, ENABLED]
#469	COLLATE HOLD	DISABLED [DISABLED, ENABLED]
#470	DUPLEX HOLD	DISABLED [DISABLED, ENABLED]
#473	EDGE HOLD	DISABLED [DISABLED, ENABLED]
#474	FRAME MARGIN	DISABLED [DISABLED, ENABLED]
#475	MARGIN HOLD	DISABLED [DISABLED, ENABLED]

Set Value

[FAX FEATURE LIST]

NO.	FEATURE	CURRENT SETTING
#212	TEL/FAX DELAYED RING	2 [1..9]
#319	REMOTE TURN ON	ON [OFF, ON]
#401	PRINT SENDING REPORT	ERROR [OFF, ON, ERROR]
#402	JOURNAL AUTO PRINT	ON [OFF, ON]
#404	MANUAL ANSWER MODE	TEL [TEL, TEL/FAX]
#405	FAX RESOLUTION	STANDARD [STANDARD, FINE, SUPER FINE, PHOTO]
#407	FAX DUPLEX PRINT	OFF [OFF, LONG EDGE, SHORT EDGE]
#411	OVERSEAS MODE	ERROR [NEXT FAX, ERROR, OFF]
#412	DELAYED TRANSMISSION	OFF [OFF, ON]
	DESTINATION =	
	START TIME = 00:00	
Code #413	ECM SELECTION	ON [OFF, ON]
#416	CONNECTING TONE	ON [OFF, ON]
#418	MAX FAX SPEED	33.6kbps [33.6kbps, 14.4kbps]
#419	QUICK SCAN MODE	OFF [OFF, ALWAYS]
#420	CONFIRM FAX NO.	OFF [OFF, ON]
#421	RESTRICT FAX NO.	OFF [OFF, ON]
#422	RE-ENTER FAX NO.	OFF [OFF, ON]
#424	CONFIRM NEXT DOC	OFF [OFF, ON]
#425	DIRECT SMTP XMT	OFF [OFF, ON]
#426	DELIVERY NOTICE	ON [OFF, ON]
#428	POP TIMER	3min [0..60(min)]
#432	AUTO REDUCTION	ON [OFF, ON]
#434	FAX ACTIVATION CODE	ON [OFF, ON]
	CODE = *#9	
Code #436	SILENT FAX RECOGNITION RING	3 [3..9]
#437	MEMORY RECEIVE ALERT	ON [OFF, ON]
#438	FRIENDLY RECEPTION	ON [OFF, ON]
#442	PCFAX SETTING	CONNECTED [OFF, ALWAYS, CONNECTED]
#443	PCFAX RCV PC	USB HOST
#448	PREVIEW MODE	OFF [OFF, ON]
#450	WEB FAX PREVIEW	
#451	RECEIVE NOTIFY	OFF [OFF, ON]
#452	FAX AUTO EMAIL	OFF [OFF, ON]
#458	ERASE FAX MEMORY	
#459	SET FAX DEFAULT	

[PC PRINT FEATURE LIST]

NO.	FEATURE	CURRENT SETTING
#760	PCL PAPER SOURCE	#1 [#1, #2, #3, #1+#2, #1+#3, #2+#3, #1+#2+#3]
#762	PCL COPIES	1 [1..999]
#763	PRINT FORMAT	A4 [LETTER, A4, LEGAL, B5(ISO), B5(JIS), 16K, 216X330, 216X340, A5, A6, B6(ISO), B6(JIS)]
#764	IMAGE REDUCTION	ON [OFF, ON]
#765	PCL ORIENTATION	PORTRAIT [PORTRAIT, LANDSCAPE]
#766	A4 WIDE	OFF [OFF, ON]
#767	LINES PER PAGE	64 [5..128]
#768	FONT SOURCE	RESIDENT [RESIDENT, DOWNLOAD FONT]
#769	FONT NUMBER	0 [0..54]
#770	FONT PITCH/POINT	10.00 [0.44...99.99]
#771	SYMBOL SET	PC-8
#772	CR/LF/FF	CR/LF/FF [CR/LF/FF, CR+LF/LF/FF, CR/CR+LF/CR+FF]
#773	AUTO CONTINUE	OFF [OFF, 20s, 30s, 60s, 90s, 120s]
#774	DATA TIMEOUT	60s [5..600(s)]
#776	MUTUAL A4/LETTER	ON [OFF, ON]

[SCAN FEATURE LIST]

NO.	FEATURE	CURRENT SETTING	
#493	SCAN MODE	VIEWER	[VIEWER, FILE, EMAIL, OCR]
#494	SCAN PARAM. HOLD	DISABLED	[DISABLED, ENABLED]

[USB PRINT FEATURE LIST]

NO.	FEATURE	CURRENT SETTING	
#660	COPIES	1	[1...99]
#661	ORIENTATION	PORTRAIT	[PORTRAIT, LANDSCAPE]
#662	N in 1	OFF	[OFF, 2 in 1, 4 in 1, 8 in 1]
#663	Nin1 PAGE BORDER	NONE	[NONE, SOLID LINE]
#664	DUPLEX	OFF	[OFF, LONG EDGE, SHORT EDGE]
#665	CONTINUOUS PRINT	ENABLED	[DISABLED, ENABLED]
#669	INPUT TRAY	#1	[#1, #2, #3, #1+#2, #1+#3, #2+#3, #1+#2+#3]
#672	DISPLAY SORT	DATE ORDER	[OFF, NAME ORDER, DATE ORDER]

[LAN FEATURE LIST]

NO.	FEATURE	CURRENT SETTING	
#500	DHCP	ENABLED	[DISABLED, ENABLED]
#501	IP ADDRESS	0.0.0.0	
#502	SUBNET MASK	0.0.0.0	
#503	DEFAULT GATEWAY	0.0.0.0	
#504	DNS SERVER #1	0.0.0.0	
#505	DNS SERVER #2	0.0.0.0	
#507	MACHINE NAME	MB2545-F0898F3A	
#508	MAC ADDRESS	00:80:F0:89:8F:3A	
#513	BONJOUR	ENABLED	[DISABLED, ENABLED]
#526	NETWORK STATUS	ENABLED	
#532	IP FILTERING	DISABLED	[DISABLED, ENABLED]
#533	AUTO IP	DISABLED	[DISABLED, ENABLED]
#534	HTTPD	ENABLED	[DISABLED, ENABLED]
#535	IPv6 PROTOCOL	DISABLED	[DISABLED, ENABLED]
#538	WINS SERVER #1	0.0.0.0	
#539	WINS SERVER #2	0.0.0.0	
#567	ADDRESS ON WEB	ENABLED	[DISABLED, ENABLED]
#569	JOURNAL ON WEB	ENABLED	[DISABLED, ENABLED]
#578	ERASE ADDRESS	ENABLED	[DISABLED, ENABLED]
#580	LAN MODE	WIRED	[OFF, WIRED]
	FIRMWARE VERSION	GG71GA	Set Value

Code

Code

(KX-MB2575)

SETUP LIST

[BASIC FEATURE LIST]

NO.	FEATURE	CURRENT SETTING
#101	SET DATE & TIME	01 Jan. 2013 00:02
#102	YOUR LOGO	
#103	YOUR FAX NUMBER	
#110	LANGUAGE	ENGLISH [ENGLISH, CZECH, FRENCH, GERMAN, HUNGARIAN, POLISH, PORTUGUESE, SLOVAK, SPANISH, TURKISH]
#114	LOCATION	GERMANY [BELGIUM, CZECH, EUR.STANDARD, FRANCE, GERMANY, HUNGARY, NETHERLANDS, POLAND, PORTUGAL, SLOVAKIA, SPAIN, U.K.]
#120	DIALLING MODE	TONE [TONE, PULSE]
#121	SET FLASH TIME	100ms [900, 700, 600, 400, 300, 250, 200, 160, 110, 100, 90, 80(ms)]
#124	ADSL MODE	OFF [OFF, ON]
#145	LCD CONTRAST	0 [-2, -1, 0, 1, 2]
#147	SCALE	MILLIMETRES [MILLIMETRES, INCHES]
#148	DISPLAY INTERVAL	1sec [1sec, 2sec, 3sec, 4sec, 5sec]
#151	ADMIN CODE	
#154	MODE RESTRICTION	OFF [OFF, ON]
#155	CHANGE PASSWORD	
#158	MAINTENANCE TIME	00:00
#159	RESTORE DEFAULT	
#161	RINGER PATTERN	A [A, B, C]
#165	BEEP SOUND	ON [OFF, ON]
#174	JOB END NOTIFY	OFF [OFF, ON]
#210	FAX RING COUNT	2 [1...9]
#289	ERASE ADDR. BOOK	
#380	PAPER SIZE #1	A4 [LETTER, A4, LEGAL, B5(ISO), B5(JIS), 16K, 216x330, 216x340, A5]
#381	PAPER SIZE #2	A4 [LETTER, A4, LEGAL, B5(ISO), B5(JIS), 16K, 216x330, 216x340, A5, A6, B6(ISO), B6(JIS)]
#382	PAPER SIZE #3	A4 [LETTER, A4, LEGAL, B5(ISO), B5(JIS), 16K, 216x330, 216x340, A5]
#383	MEDIA TYPE #1	PLAIN PAPER [PLAIN PAPER, THIN PAPER]
#384	MEDIA TYPE #2	PLAIN PAPER [PLAIN PAPER, THIN PAPER, THICK PAPER]
#385	MEDIA TYPE #3	PLAIN PAPER [PLAIN PAPER, THIN PAPER]
#390	LIST PRINT TRAY	#1 [#1, #3, #1+#3]
#403	POWER SAVE	1min [1min, 5min, 15min, 30min, 45min]
#462	CONTRAST HOLD	DISABLED [DISABLED, ENABLED]
#463	DEFAULT MODE	COPY [COPY, FAX]
#464	MODE TIMER	1min [OFF, 30s, 1min, 2min, 5min]
#479	DEPT. COUNT VIEW	
#482	TONER SAVE	OFF Set Value [OFF, ON]

[COPY FEATURE LIST]

NO.	FEATURE	CURRENT SETTING
#460	COPY INPUT TRAY	#1 [#1, #2, #3, #1+#2, #1+#3, #2+#3, #1+#2+#3]
#461	COPY RESOLUTION	TEXT/PHOTO [TEXT/PHOTO, TEXT, PHOTO]
#467	PAGE LAYOUT HOLD	DISABLED [DISABLED, ENABLED]
#468	ZOOM HOLD	DISABLED [DISABLED, ENABLED]
#469	COLLATE HOLD	DISABLED [DISABLED, ENABLED]
#470	DUPLEX HOLD	DISABLED [DISABLED, ENABLED]
#473	EDGE HOLD	DISABLED [DISABLED, ENABLED]
#474	FRAME MARGIN	DISABLED [DISABLED, ENABLED]
#475	MARGIN HOLD	DISABLED [DISABLED, ENABLED]

[FAX FEATURE LIST]

NO.	FEATURE	CURRENT SETTING
#212	TEL/FAX DELAYED RING	2 [1...9]
#319	REMOTE TURN ON	ON [OFF, ON]
#401	PRINT SENDING REPORT	ERROR [OFF, ON, ERROR]
#402	JOURNAL AUTO PRINT	ON [OFF, ON]
#404	MANUAL ANSWER MODE	TEL [TEL, TEL/FAX]
#405	FAX RESOLUTION	STANDARD [STANDARD, FINE, SUPER FINE, PHOTO]
#407	FAX DUPLEX PRINT	OFF [OFF, LONG EDGE, SHORT EDGE]
#411	OVERSEAS MODE	ERROR [NEXT FAX, ERROR, OFF]
#412	DELAYED TRANSMISSION	OFF [OFF, ON]
		DESTINATION =
		START TIME = 00:00
Code	#413 ECM SELECTION	ON [OFF, ON]
	#416 CONNECTING TONE	ON [OFF, ON]
	#418 MAX FAX SPEED	33.6kbps [33.6kbps, 14.4kbps]
	#419 QUICK SCAN MODE	OFF [OFF, ALWAYS]
	#420 CONFIRM FAX NO.	OFF [OFF, ON]
	#421 RESTRICT FAX NO.	OFF [OFF, ON]
	#422 RE-ENTER FAX NO.	OFF [OFF, ON]
	#424 CONFIRM NEXT DOC	OFF [OFF, ON]
	#425 DIRECT SMTP XMT	OFF [OFF, ON]
	#426 DELIVERY NOTICE	ON [OFF, ON]
	#428 POP TIMER	3min [0...60(min)]
	#432 AUTO REDUCTION	ON [OFF, ON]
	#434 FAX ACTIVATION CODE	ON [OFF, ON]
		CODE = *#9
Code	#436 SILENT FAX RECOGNITION RING	3 [3...9]
	#437 MEMORY RECEIVE ALERT	ON [OFF, ON]
	#438 FRIENDLY RECEPTION	ON [OFF, ON]
	#440 FAX INPUT TRAY	AUTO [#1, #3, AUTO]
	#442 PCFAX SETTING	CONNECTED [OFF, ALWAYS, CONNECTED]
	#443 PCFAX RCV PC	USB HOST
	#448 PREVIEW MODE	OFF [OFF, ON]
	#450 WEB FAX PREVIEW	
	#451 RECEIVE NOTIFY	OFF [OFF, ON]
	#452 FAX AUTO EMAIL	OFF Set Value [OFF, ON]
	#458 ERASE FAX MEMORY	
	#459 SET FAX DEFAULT	

[PC PRINT FEATURE LIST]

NO.	FEATURE	CURRENT SETTING
#760	PCL PAPER SOURCE	#1 [#1, #2, #3, #1+#2, #1+#3, #2+#3, #1+#2+#3]
#762	PCL COPIES	1 [1...999]
#763	PRINT FORMAT	A4 Set Value [LETTER, A4, LEGAL, B5(ISO), B5(JIS), 16K, 216X330, 216X340, A5, A6, B6(ISO), B6(JIS)]
#764	IMAGE REDUCTION	ON [OFF, ON]
#765	PCL ORIENTATION	PORTRAIT [PORTRAIT, LANDSCAPE]
#766	A4 WIDE	OFF [OFF, ON]
#767	LINES PER PAGE	64 [5...128]
#768	FONT SOURCE	RESIDENT [RESIDENT, DOWNLOAD FONT]
#769	FONT NUMBER	0 [0...54]
#770	FONT PITCH/POINT	10.00 [0.44...99.99]
#771	SYMBOL SET	PC-8
#772	CR/LF/FF	CR/LF/FF [CR/LF/FF, CR+LF/LF/FF, CR/CR+LF/CR+FF]
#773	AUTO CONTINUE	OFF [OFF, 20s, 30s, 60s, 90s, 120s]
#774	DATA TIMEOUT	60s [5...600(s)]
#776	MUTUAL A4/LETTER	ON [OFF, ON]

[SCAN FEATURE LIST]

NO.	FEATURE	CURRENT	SETTING
#493	SCAN MODE	VIEWER	[VIEWER, FILE, EMAIL, OCR]
#494	SCAN PARAM. HOLD	DISABLED	[DISABLED, ENABLED]

[USB PRINT FEATURE LIST]

NO.	FEATURE	CURRENT	SETTING
#660	COPIES	1	[1...99]
#661	ORIENTATION	PORTRAIT	[PORTRAIT, LANDSCAPE]
#662	N in 1	OFF	[OFF, 2 in 1, 4 in 1, 8 in 1]
#663	N in 1 PAGE BORDER	NONE	[NONE, SOLID LINE]
#664	DUPLEX	OFF	[OFF, LONG EDGE, SHORT EDGE]
#665	CONTINUOUS PRINT	ENABLED	[DISABLED, ENABLED]
#669	INPUT TRAY	#1	[#1, #2, #3, #1+#2, #1+#3, #2+#3, #1+#2+#3]
#672	DISPLAY SORT	DATE ORDER	[OFF, NAME ORDER, DATE ORDER]

[LAN FEATURE LIST]

NO.	FEATURE	CURRENT	SETTING
#500	DHCP	ENABLED	[DISABLED, ENABLED]
#501	IP ADDRESS	10.178.14.208	
#502	SUBNET MASK	255.255.254.0	
#503	DEFAULT GATEWAY	10.178.14.1	
#504	DNS SERVER #1	10.75.17.165	
#505	DNS SERVER #2	133.185.137.47	
#507	MACHINE NAME	MB2575-F00E79B4	
#508	MAC ADDRESS	00:80:F0:0E:79:B4	
#513	BONJOUR	ENABLED	[DISABLED, ENABLED]
#526	NETWORK STATUS	DISABLED	[DISABLED, ENABLED]
#532	IP FILTERING	DISABLED	[DISABLED, ENABLED]
#533	AUTO IP	DISABLED Set Value	[DISABLED, ENABLED]
#534	HTTPD	ENABLED	[DISABLED, ENABLED]
#535	IPV6 PROTOCOL	DISABLED	[DISABLED, ENABLED]
#538	WINS SERVER #1	10.75.17.165	
#539	WINS SERVER #2	133.185.137.47	
#567	ADDRESS ON WEB	ENABLED	[DISABLED, ENABLED]
#569	JOURNAL ON WEB	ENABLED	[DISABLED, ENABLED]
#578	ERASE ADDRESS		
#580	LAN MODE	WIRED	[OFF, WIRED, WIRELESS]
#581	WIRELESS STATUS		
#582	WPS-PBC		
#583	WPS-PIN		
#584	SSID SEARCH		
#585	CONFIGURATION		
#586	WIRELESS RESTORE		
	FIRMWARE VERSION	GG81GA	

Code

Code

Set Value

(DP-MB310EU)

SETUP LIST

[BASIC FEATURE LIST]

NO.	FEATURE	CURRENT SETTING
#101	SET DATE & TIME	01 Jan. 2013 00:00
#102	YOUR LOGO	
#103	YOUR FAX NUMBER	
#110	LANGUAGE	ENGLISH [ENGLISH, CZECH, FRENCH, GERMAN, HUNGARIAN, POLISH, PORTUGUESE, SLOVAK, SPANISH, TURKISH]
#114	LOCATION	GERMANY [BELGIUM, CZECH, EUR. STANDARD, FRANCE, GERMANY, HUNGARY, NETHERLANDS, POLAND, PORTUGAL, SLOVAKIA, SPAIN, U.K.]
#120	DIALLING MODE	-tone [TONE, PULSE]
#121	SET FLASH TIME	100ms [900, 700, 600, 400, 300, 250, 200, 160, 110, 100, 90, 80 (ms)]
#124	ADSL MODE	OFF [OFF, ON]
#145	LCD CONTRAST	0 [-2, -1, 0, 1, 2]
#147	SCALE	MILLIMETRES [MILLIMETRES, INCHES]
#148	DISPLAY INTERVAL	1sec [1sec, 2sec, 3sec, 4sec, 5sec]
#151	ADMIN CODE	
#154	MODE RESTRICTION	OFF [OFF, ON]
#155	CHANGE PASSWORD	
#158	MAINTENANCE TIME	00:00
#159	RESTORE DEFAULT	
#161	RINGER PATTERN	A [A, B, C]
#165	BEEP SOUND	ON [OFF, ON]
#174	JOB END NOTIFY	OFF [OFF, ON]
#210	FAX RING COUNT	2 [1...9]
#289	ERASE ADDR. BOOK	
#380	PAPER SIZE #1	A4 [LETTER, A4, LEGAL, B5 (ISO), B5 (JIS), 16K, 216X330, 216X340, A5]
#381	PAPER SIZE #2	A4 [LETTER, A4, LEGAL, B5 (ISO), B5 (JIS), 16K, 216X330, 216X340, A5, A6, B6 (ISO), B6 (JIS)]
#382	PAPER SIZE #3	A4 [LETTER, A4, LEGAL, B5 (ISO), B5 (JIS), 16K, 216X330, 216X340, A5]
#383	MEDIA TYPE #1	PLAIN PAPER [PLAIN PAPER, THIN PAPER]
#384	MEDIA TYPE #2	PLAIN PAPER [PLAIN PAPER, THIN PAPER, THICK PAPER]
#385	MEDIA TYPE #3	PLAIN PAPER [PLAIN PAPER, THIN PAPER]
#390	LIST PRINT TRAY	#1 [#1, #3, #1+#3]
#403	POWER SAVE	1min [1min, 5min, 15min, 30min, 45min]
#462	CONTRAST HOLD	DISABLED [DISABLED, ENABLED]
#463	DEFAULT MODE	COPY [COPY, FAX]
#464	MODE TIMER	1min [OFF, 30s, 1min, 2min, 5min]
#479	DEPT. COUNT VIEW	
#482	TONER SAVE	OFF Set Value [OFF, ON]

Code

Code

[COPY FEATURE LIST]

NO.	FEATURE	CURRENT SETTING
#460	COPY INPUT TRAY	#1 [#1, #2, #3, #1+#2, #1+#3, #2+#3, #1+#2+#3]
#461	COPY RESOLUTION	TEXT/PHOTO [TEXT/PHOTO, TEXT, PHOTO]
#467	PAGE LAYOUT HOLD	DISABLED [DISABLED, ENABLED]
#468	ZOOM HOLD	DISABLED [DISABLED, ENABLED]
#469	COLLATE HOLD	DISABLED [DISABLED, ENABLED]
#470	DUPLEX HOLD	DISABLED [DISABLED, ENABLED]
#473	EDGE HOLD	DISABLED [DISABLED, ENABLED]
#474	FRAME MARGIN	DISABLED [DISABLED, ENABLED]
#475	MARGIN HOLD	DISABLED [DISABLED, ENABLED]

Set Value

[FAX FEATURE LIST]

NO.	FEATURE	CURRENT SETTING
#212	TEL/FAX DELAYED RING	2 [1..9]
#319	REMOTE TURN ON	ON [OFF,ON]
#401	PRINT SENDING REPORT	ERROR [OFF,ON,ERROR]
#402	JOURNAL AUTO PRINT	ON [OFF,ON]
#404	MANUAL ANSWER MODE	TEL [TEL,TEL/FAX]
#405	FAX RESOLUTION	STANDARD [STANDARD,FINE,SUPER FINE,PHOTO]
#407	FAX DUPLEX PRINT	OFF [OFF,LONG EDGE,SHORT EDGE]
#411	OVERSEAS MODE	ERROR [NEXT FAX,ERROR,OFF]
#412	DELAYED TRANSMISSION	OFF [OFF,ON]
	DESTINATION =	
	START TIME = 00:00	
Code #413	ECM SELECTION	ON [OFF,ON]
#416	CONNECTING TONE	ON [OFF,ON]
#418	MAX FAX SPEED	33.6kbps [33.6kbps,14.4kbps]
#419	QUICK SCAN MODE	OFF [OFF,ALWAYS]
#420	CONFIRM FAX NO.	OFF [OFF,ON]
#421	RESTRICT FAX NO.	OFF [OFF,ON]
#422	RE-ENTER FAX NO.	OFF [OFF,ON]
#424	CONFIRM NEXT DOC	OFF [OFF,ON]
#425	DIRECT SMTP XMT	OFF [OFF,ON]
#426	DELIVERY NOTICE	ON [OFF,ON]
#428	POP TIMER	3min [0..60(min)]
#432	AUTO REDUCTION	ON [OFF,ON]
#434	FAX ACTIVATION CODE	ON [OFF,ON]
	CODE = *#9	
Code #436	SILENT FAX RECOGNITION RING	3 [3..9]
#437	MEMORY RECEIVE ALERT	ON [OFF,ON]
#438	FRIENDLY RECEPTION	ON [OFF,ON]
#440	FAX INPUT TRAY	AUTO [#1,#3,AUTO]
#442	PCFAX SETTING	CONNECTED [OFF,ALWAYS,CONNECTED]
#443	PCFAX RCV PC	USB HOST
#448	PREVIEW MODE	OFF [OFF,ON]
#450	WEB FAX PREVIEW	
#451	RECEIVE NOTIFY	OFF [OFF,ON]
#452	FAX AUTO EMAIL	OFF Set Value [OFF,ON]
#458	ERASE FAX MEMORY	
#459	SET FAX DEFAULT	

[PC PRINT FEATURE LIST]

NO.	FEATURE	CURRENT SETTING
#760	PCL PAPER SOURCE	#1 [#1,#2,#3,#1+#2,#1+#3,#2+#3,#1+#2+#3]
#762	PCL COPIES	1 [1..999]
#763	PRINT FORMAT	A4 [LETTER,A4,LEGAL,B5(ISO),B5(JIS),16K,216X330,216X340,A5,A6,B6(ISO),B6(JIS)]
#764	IMAGE REDUCTION	ON [OFF,ON]
#765	PCL ORIENTATION	PORTRAIT [PORTRAIT,LANDSCAPE]
#766	A4 WIDE	OFF [OFF,ON]
#767	LINES PER PAGE	64 [5..128]
#768	FONT SOURCE	RESIDENT [RESIDENT,DOWNLOAD FONT]
#769	FONT NUMBER	0 [0..54]
#770	FONT PITCH/POINT	10.00 [0.44..99.99]
#771	SYMBOL SET	PC-8
#772	CR/LF/FF	CR/LF/FF [CR/LF/FF,CR+LF/LF/FF,CR/CR+LF/CR+FF]
#773	AUTO CONTINUE	OFF [OFF,20s,30s,60s,90s,120s]
#774	DATA TIMEOUT	60s [5..600(s)]
#776	MUTUAL A4/LETTER	ON [OFF,ON]

[SCAN FEATURE LIST]

NO.	FEATURE	CURRENT SETTING	
#493	SCAN MODE	VIEWER	[VIEWER, FILE, EMAIL, OCR]
#494	SCAN PARAM. HOLD	DISABLED	[DISABLED, ENABLED]

[USB PRINT FEATURE LIST]

NO.	FEATURE	CURRENT SETTING	
#660	COPIES	1	[1...99]
#661	ORIENTATION	PORTRAIT	[PORTRAIT, LANDSCAPE]
#662	N in 1	OFF	[OFF, 2 in 1, 4 in 1, 8 in 1]
#663	Ninl PAGE BORDER	NONE	[NONE, SOLID LINE]
#664	DUPLEX	OFF	[OFF, LONG EDGE, SHORT EDGE]
#665	CONTINUOUS PRINT	ENABLED	[DISABLED, ENABLED]
#669	INPUT TRAY	#1	[#1, #2, #3, #1+#2, #1+#3, #2+#3, #1+#2+#3]
#672	DISPLAY SORT	DATE ORDER	[OFF, NAME ORDER, DATE ORDER]

[LAN FEATURE LIST]

NO.	FEATURE	CURRENT SETTING	
#500	DHCP	ENABLED	[DISABLED, ENABLED]
#501	IP ADDRESS	10.178.14.208	
#502	SUBNET MASK	255.255.254.0	
#503	DEFAULT GATEWAY	10.178.14.1	
#504	DNS SERVER #1	10.75.17.165	
#505	DNS SERVER #2	133.185.137.47	
#507	MACHINE NAME	MB310-F00E79B4	
#508	MAC ADDRESS	00:80:F0:0E:79:B4	
#513	BONJOUR	ENABLED	[DISABLED, ENABLED]
#526	NETWORK STATUS		
#532	IP FILTERING	DISABLED	[DISABLED, ENABLED]
#533	AUTO IP	DISABLED Set Value	[DISABLED, ENABLED]
#534	HTTPD	ENABLED	[DISABLED, ENABLED]
#535	IPv6 PROTOCOL	DISABLED	[DISABLED, ENABLED]
#538	WINS SERVER #1	10.75.17.165	
#539	WINS SERVER #2	133.185.137.47	
#567	ADDRESS ON WEB	ENABLED	[DISABLED, ENABLED]
#569	JOURNAL ON WEB	ENABLED	[DISABLED, ENABLED]
#578	ERASE ADDRESS		
#580	LAN MODE	WIRED	[OFF, WIRED]

FIRMWARE VERSION

GG91GA Set Value

Code

Code

Note:

The above values are the default values.

11.3. Service Mode Settings (Example of a printed out list)

(KX-MB2230)

[SERVICE DATA LIST]

Code	501 PAUSE TIME	=	030*100ms	[001...600]*100ms				
	503 DIAL SPEED	=	10pps	[1=10 2=20]pps				
	514 BELL DETECT TIME	=	3*100ms	[1...9]*100ms				
	520 CED FREQUENCY	=	2100Hz	[1=2100 2=1100]Hz				
	521 INTERNATIONAL MODE	=	ON	[1=ON 2=OFF]				
	522 AUTO STANDBY	=	ON	[1=ON 2=OFF]				
	523 RX EQUALIZER	=	0.0Km	[1=0.0 2=1.8 3=3.6 4=7.2]Km				
	524 TX EQUALIZER	=	0.0Km	[1=0.0 2=1.8 3=3.6 4=7.2]Km				
	853 TOP MARGIN	=	06*0.5mm	[01...11]*0.5mm				
	854 LEFT MARGIN	=	06*0.5mm	[01...11]*0.5mm				
	856 TOP MARGIN(DUPLEX)	=	06*0.5mm	[01...11]*0.5mm				
	871 LEFT MARGIN(DUPLEX)	=	06*0.5mm	[01...11]*0.5mm				
	874 DTMF ON TIME	=	100ms	[060...200]ms				
	875 DTMF OFF TIME	=	100ms	[060...200]ms				

Set Value

[SPECIAL SERVICE SETTINGS]

Code	507	508	552	553	567	570	573	590	591	592	593	594	595
	1	1	2	1	052	1	10	05	065	2	1	1	2
	596	598	599	717	718	774	775						
	10	48	1	1	1	00	00						

Set Value

USAGE TIME = 250 HOURS

Version = GFJ1GB C077

(KX-MB2270)

[SERVICE DATA LIST]

Code	501 PAUSE TIME	=	030*100ms	[001...600]*100ms				
	503 DIAL SPEED	=	10pps	[1=10 2=20]pps				
	514 BELL DETECT TIME	=	3*100ms	[1...9]*100ms				
	520 CED FREQUENCY	=	2100Hz	[1=2100 2=1100]Hz				
	521 INTERNATIONAL MODE	=	OFF	[1=ON 2=OFF]				
	522 AUTO STANDBY	=	ON	[1=ON 2=OFF]				
	523 RX EQUALIZER	=	0.0Km	[1=0.0 2=1.8 3=3.6 4=7.2]Km				
	524 TX EQUALIZER	=	0.0Km	[1=0.0 2=1.8 3=3.6 4=7.2]Km				
	853 TOP MARGIN	=	06*0.5mm	[01...11]*0.5mm				
	854 LEFT MARGIN	=	06*0.5mm	[01...11]*0.5mm				
	856 TOP MARGIN(DUPLEX)	=	06*0.5mm	[01...11]*0.5mm				
	871 LEFT MARGIN(DUPLEX)	=	06*0.5mm	[01...11]*0.5mm				
	874 DTMF ON TIME	=	100ms	[060...200]ms				
	875 DTMF OFF TIME	=	100ms	[060...200]ms				

Set Value

[SPECIAL SERVICE SETTINGS]

Code	507	508	552	553	567	570	573	590	591	592	593	594	595
	1	1	2	1	052	1	10	05	065	2	1	1	2
	596	598	599	717	718	774	775						
	10	48	1	1	1	00	00						

Set Value

USAGE TIME = 0 HOURS

Version = GG21GA 344C

(KX-MB2545)

[SERVICE DATA LIST]

	501 PAUSE TIME	=	030*100ms	[001...600]*100ms				
	503 DIAL SPEED	=	10pps	[1=10 2=20]pps				
	514 BELL DETECT TIME	=	3*100ms	[1...9]*100ms				
Code	520 CED FREQUENCY	=	2100Hz	[1=2100 2=1100]Hz				
	521 INTERNATIONAL MODE	=	OFF	[1=ON 2=OFF]				
	522 AUTO STANDBY	=	ON	[1=ON 2=OFF]				
	523 RX EQUALIZER	=	0.0Km	[1=0.0 2=1.8	3=3.6	4=7.2]Km		
	524 TX EQUALIZER	=	0.0Km	[1=0.0 2=1.8	3=3.6	4=7.2]Km		
	853 TOP MARGIN	=	06*0.5mm	[01...11]*0.5mm				
	854 LEFT MARGIN	=	06*0.5mm	[01...11]*0.5mm				
	856 TOP MARGIN(DUPLEX)	=	06*0.5mm	[01...11]*0.5mm				
	870 LEFT MARGIN(OPF)	=	06*0.5mm	[01...11]*0.5mm				
	871 LEFT MARGIN(DUPLEX)	=	06*0.5mm	[01...11]*0.5mm				
	874 DTMF ON TIME	=	100ms	{060...200}ms				
	875 DTMF OFF TIME	=	100ms	{060...200}ms				

Set Value

[SPECIAL SERVICE SETTINGS]

	507	508	552	553	567	570	573	590	591	592	593	594	595
	1	1	2	1	052	1	10	05	065	2	1	1	2
Code	596	598	599	717	718	774	775						
	10	48	1	1	1	00	00						

Set Value

USAGE TIME = 1 HOURS

Version = GG71GA 6837

(KX-MB2575)

[SERVICE DATA LIST]

	501 PAUSE TIME	=	030*100ms	[001...600]*100ms				
	503 DIAL SPEED	=	10pps	[1=10 2=20]pps				
	514 BELL DETECT TIME	=	3*100ms	[1...9]*100ms				
Code	520 CED FREQUENCY	=	2100Hz	[1=2100 2=1100]Hz				
	521 INTERNATIONAL MODE	=	OFF	[1=ON 2=OFF]				
	522 AUTO STANDBY	=	ON	[1=ON 2=OFF]				
	523 RX EQUALIZER	=	0.0Km	[1=0.0 2=1.8	3=3.6	4=7.2]Km		
	524 TX EQUALIZER	=	0.0Km	[1=0.0 2=1.8	3=3.6	4=7.2]Km		
	853 TOP MARGIN	=	06*0.5mm	[01...11]*0.5mm				
	854 LEFT MARGIN	=	06*0.5mm	[01...11]*0.5mm				
	856 TOP MARGIN(DUPLEX)	=	06*0.5mm	[01...11]*0.5mm				
	870 LEFT MARGIN(OPF)	=	06*0.5mm	[01...11]*0.5mm				
	871 LEFT MARGIN(DUPLEX)	=	06*0.5mm	[01...11]*0.5mm				
	874 DTMF ON TIME	=	100ms	{060...200}ms				
	875 DTMF OFF TIME	=	100ms	{060...200}ms				

Set Value

[SPECIAL SERVICE SETTINGS]

	507	508	552	553	567	570	573	590	591	592	593	594	595
	1	1	2	1	052	1	10	05	065	2	1	1	2
Code	596	598	599	717	718	774	775						
	10	48	1	1	1	00	00						

Set Value

USAGE TIME = 0 HOURS

Version = GG81GA 2F4D

(DP-MB310EU)

[SERVICE DATA LIST]

	501 PAUSE TIME	=	030*100ms	[001...600]*100ms			
	503 DIAL SPEED	=	10pps	[1=10 2=20]pps			
	514 BELL DETECT TIME	=	3*100ms	[1...9]*100ms			
Code	520 CED FREQUENCY	=	2100Hz	[1=2100 2=1100]Hz			
	521 INTERNATIONAL MODE	=	OFF	[1=ON 2=OFF]			
	522 AUTO STANDBY	=	ON	[1=ON 2=OFF]			
	523 RX EQUALIZER	=	0.0Km	[1=0.0 2=1.8 3=3.6 4=7.2]Km			
	524 TX EQUALIZER	=	0.0Km	[1=0.0 2=1.8 3=3.6 4=7.2]Km			
	853 TOP MARGIN	=	06*0.5mm	[01...11]*0.5mm			
	854 LEFT MARGIN	=	06*0.5mm	[01...11]*0.5mm			
	856 TOP MARGIN(DUPLEX)	=	06*0.5mm	[01...11]*0.5mm			
	870 LEFT MARGIN(OPF)	=	06*0.5mm	[01...11]*0.5mm			
	871 LEFT MARGIN(DUPLEX)	=	06*0.5mm	[01...11]*0.5mm			
	874 DTMF ON TIME	=	100ms	[060...200]ms			
	875 DTMF OFF TIME	=	100ms	[060...200]ms			

Set Value

[SPECIAL SERVICE SETTINGS]

Code	507	508	552	553	567	570	573	590	591	592	593	594	595
	1	1	2	1	052	1	10	05	065	2	1	1	2
	596	598	599	717	718	774	775						
	10	48	1	1	1	00	00						

Set Value

USAGE TIME = 0 HOURS

Version = GG91GA 63EF

Note:

The above values are the default values.

11.4. History (Example of a printed out list)

(KX-MB2230)

[HISTORY]

Model	: MB2230EU	Usage Time	: 000250
Rom Version(Main)	: GFJ1GB	Receive Mode	: FAX
Check SUM	: C077	Number of Copy	: 000000
		Number of Receive	: 000003
		Number of Send	: 000014
Your LOGO	:		
Your Fax NO	:	Drum Print Count	: 00017
First Setting Date/Time	:	Drum Paddle Count	: 00177
Month	: 01	Toner Print Count	: 000017
Day	: 01	Toner Simulated Count	: 000010
Year	: 2013	Toner Paddle Count	: 000182
Hour/Minute	: 0000	Total Print Count	: 0000015
Factory to Customer(Day)	: 00001	Total Simulated Count	: 0000010
Factory to Now(Day)	: 00035	Duplex Count	: 0000000
Power On Count	: 0000012		
USB NO	: 000000000000		
MAC ADDRESS	: 00:80:F0:0E:79:B5		

(1)	(2)	(3)	(4)	(5)	(6)
0 0 0 0 0 0	0 0 0 2 5 0	0 0 0 0 0 0	0 0 0 0 0 0	T O N E	0 0 0 0 9
(7)	(8)	(9)	(10)	(11)	(12)
0 0 0 0 0 0	0 0 0 0 9 4	0 0 0 0 5 0	0 0 0 0 4 4	0 0 0 0 0 0	0 0 0 0
(13)	(14)	(15)	(16)	(17)	(18)
0 0 0 0 0 0	0 0 0	0 0 0	0 0 0 0	0 0 0 0	0 0 0 0
(19)	(20)	(21)	(22)	(23)	(24)
0 0 0 0 0	0 0 0 0	0 0 0 0	0 0 0 0	0 0 0 0	0 0 0 0 0 0
(25)		(26)		(27)	
0 0 0 0 0 0		0 0 0 0 0 0		0 0 0 0 0 0	
(28)	(29)	(30)	(31)		
0 0 0	0 0 0	0 0 0	0 0 0 0 1 6		

NAME _____ DATE _____ DEALER _____
 CUSTOMER COMPLAINT _____

SURVEY RESULT : CKOK (UNKNOWN/DESIGN/EDUC) DEFECT (PART/WORKER/DESIGN)
 ABUSE (CUST/DEALER/SHIP) NEW (OPEN/NOT)
 PHONE SURVEY RESULT.

(KX-MB2270)

[HISTORY]

Model	: MB2270EU	Usage Time	: 000000
Rom Version(Main)	: GG21GA	Receive Mode	: FAX
Check SUM	: 344C	Number of Copy	: 000000
		Number of Receive	: 000000
		Number of send	: 000000
Your LOGO	:		
Your Fax NO	:	Drum Print Count	: 00001
First Setting Date/Time	:	Drum Paddle Count	: 00008
Month	: 01	Toner Print Count	: 000001
Day	: 01	Toner Simulated Count	: 000000
Year	: 2013	Toner Paddle Count	: 000008
Hour/Minute	: 0000	Total Print Count	: 0000001
Factory to Customer(Day)	: 00000	Total Simulated Count	: 0000000
Factory to Now(Day)	: 00000	Duplex Count	: 0000000
Power On Count	: 0000001		
USB NO	: 000000000000		
MAC ADDRESS	: 00:80:F0:0E:79:B5		

(1)	(2)	(3)	(4)	(5)	(6)
0 0 0 0 0 0	0 0 0 0 0 0	0 0 0 0 0 0	0 0 0 0 0 0	T O N E	0 0 0 0 0
(7)	(8)	(9)	(10)	(11)	(12)
0 0 0 0 0 0	0 0 0 0 0 0	0 0 0 0 0 0	0 0 0 0 0 0	0 0 0 0 0 0	0 0 0 0
(13)	(14)	(15)	(16)	(17)	(18)
0 0 0 0 0 0	0 0 0	0 0 0	0 0 0 0	0 0 0 0	0 0 0 0
(19)	(20)	(21)	(22)	(23)	(24)
0 0 0 0	0 0 0 0	0 0 0 0	0 0 0 0	0 0 0 0	0 0 0 0 0 0
(25)		(26)		(27)	
0 0 0 0 0 0		0 0 0 0 0 0		0 0 0 0 0 0	
(28)	(29)	(30)	(31)		
0 0 0	0 0 0	0 0 0	0 0 0 0 0 0		

NAME _____ DATE _____ DEALER _____
 CUSTOMER COMPLAINT _____

SURVEY RESULT : CKOK (UNKNOWN/DESIGN/EDUC) DEFECT (PART/WORKER/DESIGN)
 ABUSE (CUST/DEALER/SHIP) NEW (OPEN/NOT)
 PHONE SURVEY RESULT.

(KX-MB2515)

[HISTORY]

```

Model : MB2515EU Usage Time : 000001
Rom Version(Main) : GG51GA Receive Mode : NONE
Check SUM : AFD2 Number of Copy : 000000
Number of Receive : 000000
Number of Send : 000000

Your LOGO :
Your Fax NO :
First Setting Date/Time :
Month : 01 Drum Print Count : 00004
Day : 01 Drum Paddle Count : 00017
Year : 2013 Toner Print Count : 000004
Hour/Minute : 0000 Toner Simulated Count : 000003
Factory to Customer(Day) : 00000 Toner Paddle Count : 000017
Factory to Now(Day) : 00000 Total Print Count : 0000004
Power On Count : 0000000 Total Simulated Count : 0000003
USB NO : 10G901000104 Duplex Count : 0000000
MAC ADDRESS : 00:80:F0:89:8F:3A
    
```

(1)	(2)	(3)	(4)	(5)	(6)
0 0 0 0 0 0	0 0 0 0 0 0	0 0 0 0 0 0	0 0 0 0 0 0	N O N E	0 0 0 0 0
(7)	(8)	(9)	(10)	(11)	(12)
0 0 0 0 0	0 0 0 0 0 0	0 0 0 0 0 0	0 0 0 0 0 0	0 0 0 0 0 0	0 0 0 0
(13)	(14)	(15)	(16)	(17)	(18)
0 0 0 0 0 0	0 0 0	0 0 0	0 0 0 0	0 0 0 0	0 0 0 0
(19)	(20)	(21)	(22)	(23)	(24)
0 0 0 0	0 0 0 0	0 0 0 0	0 0 0 0	0 0 0 0	0 0 0 0 0 0
(25)		(26)		(27)	
0 0 0 0 0 0		0 0 0 0 0 0		0 0 0 0 0 0	
(28)	(29)	(30)	(31)		
0 0 0	0 0 0	0 0 0	0 0 0 0 0 0		

NAME _____ DATE _____ DEALER _____
 CUSTOMER COMPLAINT _____

SURVEY RESULT : CKOK (UNKNOWN/DESIGN/EDUC) DEFECT (PART/WORKER/DESIGN)
 ABUSE (CUST/DEALER/SHIP) NEW (OPEN/NOT)
 PHONE SURVEY RESULT.

(KX-MB2545)

[HISTORY]

```

Model                : MB2545EU                Usage Time           : 000001
Rom Version(Main)    : GG71GA                Receive Mode         : FAX
Check SUM            : 6837                  Number of Copy       : 000000
                                                            Number of Receive    : 000000
                                                            Number of Send       : 000000

Your LOGO             :
Your Fax NO           :
First Setting Date/Time
  Month               : 01                    Drum Print Count     : 00013
  Day                 : 01                    Drum Paddle Count    : 00066
  Year                : 2013                 Toner Print Count    : 000013
  Hour/Minute         : 0000                 Toner Simulated Count : 000004
  Factory to Customer(Day) : 00000                Toner Paddle Count   : 000067
  Factory to Now(Day)   : 00000                Total Print Count    : 0000013
  Power On Count       : 0000000             Total Simulated Count : 0000004
  USB NO              : 41G701000109         Duplex Count         : 0000000
  MAC ADDRESS         : 08:00:23:00:FD:6E
  
```

(1)	(2)	(3)	(4)	(5)	(6)
0 0 0 0 0 0	0 0 0 0 0 1	0 0 0 0 0 0	0 0 0 0 0 0	T O N E	0 0 0 0 0
(7)	(8)	(9)	(10)	(11)	(12)
0 0 0 0 0	0 0 0 0 0 0	0 0 0 0 0 0	0 0 0 0 0 0	0 0 0 0 0 0	0 0 0 0
(13)	(14)	(15)	(16)	(17)	(18)
0 0 0 0 0 0	0 0 0	0 0 0	0 0 0 0	0 0 0 0	0 0 0 0
(19)	(20)	(21)	(22)	(23)	(24)
0 0 0 0	0 0 0 0	0 0 0 0	0 0 0 0	0 0 0 0	0 0 0 0 0 0
(25)		(26)		(27)	
0 0 0 0 0 0		0 0 0 0 0 0		0 0 0 0 0 0	
(28)	(29)	(30)	(31)		
0 0 0	0 0 0	0 0 0	0 0 0 0 0 0		

NAME _____ DATE _____ DEALER _____
 CUSTOMER COMPLAINT

SURVEY RESULT : CKOK (UNKNOWN/DESIGN/EDUC) DEFECT (PART/WORKER/DESIGN)
 ABUSE (CUST/DEALER/SHIP) NEW (OPEN/NOT)
 PHONE SURVEY RESULT.

(KX-MB2575)

[HISTORY]

```

Model                : MB2575EU                Usage Time           : 000000
Rom Version(Main)    : GG81GA                  Receive Mode         : FAX
Check SUM            : 2F4D                    Number of Copy       : 000000
                                                            Number of Receive    : 000000
                                                            Number of Send       : 000000

Your LOGO            :
Your Fax NO          :
First Setting Date/Time
  Month              : 01                      Drum Print Count     : 00002
  Day                : 01                      Drum Paddle Count    : 00017
  Year               : 2013                   Toner Print Count    : 000002
  Hour/Minute        : 0000                   Toner Simulated Count : 000000
Factory to Customer(Day) : 00000                Toner Paddle Count   : 000018
Factory to Now(Day)   : 00000                Total Print Count    : 0000002
Power On Count        : 0000002               Total Simulated Count : 0000000
USB NO                : 0000000000000          Duplex Count         : 0000000
MAC ADDRESS           : 00:80:F0:0E:79:B4
    
```

(1)	(2)	(3)	(4)	(5)	(6)
0 0 0 0 0 0	0 0 0 0 0 0	0 0 0 0 0 0	0 0 0 0 0 0	T O N E	0 0 0 0 0
(7)	(8)	(9)	(10)	(11)	(12)
0 0 0 0 0 0	0 0 0 0 0 0	0 0 0 0 0 0	0 0 0 0 0 0	0 0 0 0 0 0	0 0 0 0 0
(13)	(14)	(15)	(16)	(17)	(18)
0 0 0 0 0 0	0 0 0	0 0 0	0 0 0 0	0 0 0 0	0 0 0 0
(19)	(20)	(21)	(22)	(23)	(24)
0 0 0 0	0 0 0 0	0 0 0 0	0 0 0 0	0 0 0 0	0 0 0 0 0 0
(25)		(26)		(27)	
0 0 0 0 0 0		0 0 0 0 0 0		0 0 0 0 0 0	
(28)	(29)	(30)	(31)		
0 0 0	0 0 0	0 0 0	0 0 0 0 0 0		

NAME _____ DATE _____ DEALER _____
 CUSTOMER COMPLAINT _____

SURVEY RESULT : CKOK (UNKNOWN/DESIGN/EDUC) DEFECT (PART/WORKER/DESIGN)
 ABUSE (CUST/DEALER/SHIP) NEW (OPEN/NOT)
 PHONE SURVEY RESULT.

(DP-MB310EU)

[HISTORY]

Model	: MB310EU	Usage Time	: 000000
Rom Version(Main)	: GG91GA	Receive Mode	: FAX
Check SUM	: 63EF	Number of Copy	: 000000
		Number of Receive	: 000000
		Number of Send	: 000000
Your LOGO	:		
Your Fax NO	:	Drum Print Count	: 00001
First Setting Date/Time	:	Drum Paddle Count	: 00008
Month	: 01	Toner Print Count	: 000001
Day	: 01	Toner Simulated Count	: 000000
Year	: 2013	Toner Paddle Count	: 000008
Hour/Minute	: 0000	Total Print Count	: 0000001
Factory to Customer(Day)	: 00000	Total Simulated Count	: 0000000
Factory to Now(Day)	: 00000	Duplex Count	: 0000000
Power On Count	: 0000001		
USB NO	: 000000000000		
MAC ADDRESS	: 00:80:F0:0E:79:B4		

(1)	(2)	(3)	(4)	(5)	(6)
0 0 0 0 0 0	0 0 0 0 0 0	0 0 0 0 0 0	0 0 0 0 0 0	T O N E	0 0 0 0 0
(7)	(8)	(9)	(10)	(11)	(12)
0 0 0 0 0 0	0 0 0 0 0 0	0 0 0 0 0 0	0 0 0 0 0 0	0 0 0 0 0 0	0 0 0 0
(13)	(14)	(15)	(16)	(17)	(18)
0 0 0 0 0 0	0 0 0	0 0 0	0 0 0 0	0 0 0 0	0 0 0 0
(19)	(20)	(21)	(22)	(23)	(24)
0 0 0 0	0 0 0 0	0 0 0 0	0 0 0 0	0 0 0 0	0 0 0 0 0 0
(25)		(26)		(27)	
0 0 0 0 0 0		0 0 0 0 0 0		0 0 0 0 0 0	
(28)	(29)	(30)	(31)		
0 0 0	0 0 0	0 0 0	0 0 0 0 0 0		

NAME _____ DATE _____ DEALER _____
 CUSTOMER COMPLAINT _____

SURVEY RESULT : CKOK (UNKNOWN/DESIGN/EDUC) DEFECT (PART/WORKER/DESIGN)
 ABUSE (CUST/DEALER/SHIP) NEW (OPEN/NOT)
 PHONE SURVEY RESULT.

Note:

- *1) Factory to Now(Day) shows the actual number of days from the production to print History. This is nothing to do with how many times or how long the power is on
- *See the following descriptions of this report. Item No. (1) ~ (31) are corresponding to the listed items in **Descriptions of the History Report (P.170)**.

11.4.1. Descriptions of the History Report

- (1) Not used (KX-MB2515 Only)
Usage Time of Receive Mode (Tel Mode)
- (2) Not used (KX-MB2515 Only)
Usage Time of Receive Mode (Fax Mode)
- (3) Not used (KX-MB2515 Only)
Usage Time of Receive Mode (Tel/Fax Mode)
- (4) Not used
- (5) Not used (KX-MB2515 Only)
Dial Mode
- (6) Not used (KX-MB2515 Only)
Number of Directory Entry
- (7) Not used (KX-MB2515 Only)
Number of Caller ID
- (8) Number of Scan
- (9) Number of ADF Scan
- (10) Number of Flatbed Scan
- (11) Number of PC Scan
- (12) Number of Document JAM
- (13) Number of Print
- (14) Number of Warning List
- (15) Number of Help List
- (16) Call Service 3 Information 1
- (17) Call Service 3 Information 2
- (18) Call Service 3 Information 3
- (19) Number of Recording paper JAM
- (20) Number of Pickup Errors in Cassette 1
- (21) Number of Pickup Errors in Manual Feed
- (22) Number of Pickup Errors in Option
- (23) Not used
- (24) Not used
- (25) Not Used
- (26) Not Used
- (27) Number of Copies
- (28) Jam Information 1
- (29) Jam Information 2
- (30) Jam Information 3
- (31) Number of ADF Feed for document reorder and document exit when cancel scanning

12 Troubleshooting Guide

12.1. User Recoverable Errors

If the unit detects a problem, one or more of the following messages will appear on the display.

The explanations given in the [] are for servicemen only.

General messages

DISPLAY MESSAGE	CAUSE AND REMEDY
CALL SERVICE 1	<ul style="list-style-type: none"> Polygon motor error. Refer to CALL SERVICE 1 (P.189).
CALL SERVICE 2	<ul style="list-style-type: none"> Laser beam error. Replace LSU unit. Refer to CALL SERVICE 2 (P.190).
CALL SERVICE 3	<ul style="list-style-type: none"> Fuser unit cannot heat up. Replace fuser unit. Refer to CALL SERVICE 3 (P.191).
CALL SERVICE 4	<ul style="list-style-type: none"> Fan motor error. Replace fan motor. Refer to CALL SERVICE 4 (P.192).
CALL SERVICE 5	<ul style="list-style-type: none"> DC motor's rotation detection signal error. Refer to CALL SERVICE 5 (P.193).
CALL SERVICE 6	<ul style="list-style-type: none"> Charge voltage is abnormal. Refer to CALL SERVICE 6 (P.194).
CALL SERVICE 17	<ul style="list-style-type: none"> OPC First use sensor problem. Refer to CALL SERVICE 17 (P.195).
CALL SERVICE 22	<ul style="list-style-type: none"> Number of Pickup Errors in Option. Refer to CALL SERVICE 22 (P.196).
CHANGE DRUM	<ul style="list-style-type: none"> There is something wrong with the drum cartridge. Replace the drum cartridge.
CHANGE TONER	<ul style="list-style-type: none"> The toner cartridge is not inserted properly. Re-insert it correctly. There is something wrong with the toner cartridge. Replace the toner cartridge.
CHECK CARTRIDGE	<ul style="list-style-type: none"> The toner cartridge or drum cartridge is not inserted properly. Re-insert it correctly.
CHECK DOCUMENT	<ul style="list-style-type: none"> The document was not fed into the unit properly. Remove the document, and then press [Stop] to clear the message. Re-insert the document. If misfeeding occurs frequently, clean the document feeder rollers and try again. The ADF top cover is not fully closed. Push firmly on the front and rear edges of the ADF top cover, and then feed the document again.
CHECK PAPER TRAY #1	<ul style="list-style-type: none"> The loaded recording paper is not the appropriate size. Load recording paper of the size that is shown on the display. If this message is often displayed, also change the recording paper size setting (feature #380). The recording paper size setting (feature #380) is set to "A5", "B5(ISO)", "B5(JIS)" or "16K", so received faxes will have been stored into memory. Change the recording paper size setting and load the appropriate recording paper. <p>Note:</p> <ul style="list-style-type: none"> "#1": Check the standard input tray. The displayed paper size depends on the recording paper size setting (feature #380). "#2": Check the manual tray/multi-purpose tray. The displayed paper size depends on the recording paper size setting (feature #381). "#3": Check the lower input tray. The displayed paper size depends on the recording paper size setting (feature #382). <p>Refer to Program Mode Table (P.177).</p>
CHECK INSTALL INPUT TRAY #1	<ul style="list-style-type: none"> The paper input tray is not installed correctly. Pull out the paper input tray and re-insert it. <p>Note:</p> <ul style="list-style-type: none"> "#1": Standard input tray
CHECK PICK UP INPUT TRAY #1	<ul style="list-style-type: none"> Recording paper was not fed into the unit properly. Re-insert the recording paper. If misfeeding occurs frequently, clean the pickup rollers and try again. <p>Note:</p> <ul style="list-style-type: none"> "#1": Standard input tray "#2": Manual tray/multi-purpose tray "#3": Lower input tray
CHECK REAR COVER	<ul style="list-style-type: none"> The rear cover is open. Close it.

DISPLAY MESSAGE	CAUSE AND REMEDY
COOL DOWN FUSER PLEASE WAIT	<ul style="list-style-type: none"> The unit is cooling down the fuser unit. Wait for a while.
DRUM LIFE LOW	<ul style="list-style-type: none"> The drum cartridge is reaching the end of its life. If you don't have a new cartridge handy you should buy one as soon as possible as your current cartridge is near the end of its useful life.
DRUM LIFE OVER	<ul style="list-style-type: none"> The drum cartridge has reached the end of its useful life. Replace the drum cartridge immediately.
EMAIL SIZE OVER	<ul style="list-style-type: none"> When performing scan to email address, the number of scanned pages or the file size of the scanned data has exceeded the limitation. Divide the document into sections.
FAX IN MEMORY	<ul style="list-style-type: none"> The unit has a document in memory. See the other displayed message instructions to print out the document. Refer to Program Mode Table (P.177).
FAX PREVIEW	<ul style="list-style-type: none"> If the fax preview mode (feature #448) is set to "ON", <ul style="list-style-type: none"> view, print or save the received fax documents using the web browser on the computer connected via the LAN, and then erase the unnecessary documents. turn the setting to "OFF". The fax documents stored in memory will be printed automatically. Refer to Program Mode Table (P.177).
FILE SIZE OVER	<ul style="list-style-type: none"> When performing scan to FTP server or scan to SMB folder, the number of scanned pages or the file size of the scanned data has exceeded the limitation. Divide the document into sections.
FRONT COVER OPEN	<ul style="list-style-type: none"> The front cover is open. Close it.
KEEP COPYING	<ul style="list-style-type: none"> Copying has stopped due to some existing problem (Example: a lack of recording paper or a recording paper jam). See the other displayed message instructions to continue copying.
LOW TEMP.	<ul style="list-style-type: none"> The inside of the unit is extremely cold and cannot be operated. Use the unit in a warmer area.
MEMORY FULL	<ul style="list-style-type: none"> When performing memory transmission, the document being stored exceeded the memory capacity of the unit. Send the entire document manually. When making a copy, the document being stored exceeded the memory capacity of the unit. Press [Stop] to clear the message. Divide the document into sections. There is no space to store new items in the address book. Erase unnecessary items.
MODEM ERROR	<ul style="list-style-type: none"> There is something wrong with the unit's modem.
NO FAX REPLY	<ul style="list-style-type: none"> The other party's fax machine is busy or has run out of recording paper. Try again.
OUT OF PAPER INPUT TRAY #1	<ul style="list-style-type: none"> Recording paper is not loaded or the paper input tray has run out of paper. Load paper. <p>Note:</p> <ul style="list-style-type: none"> "#1": Standard input tray "#2": Manual tray/multi-purpose tray "#3": Lower input tray
PAPER IN TRAY #2	<ul style="list-style-type: none"> The recording paper is installed in the manual input tray.
PAPER JAMMED ↕ OPEN REAR COVER OPEN FRONT COVER	<ul style="list-style-type: none"> A recording paper jam occurred. Remove the jammed paper. Remove the protective sheet from the drum cartridge.
PC FAIL OR BUSY	<ul style="list-style-type: none"> The cable between the unit and the computer is not connected correctly. Check the connections. The computer has some kind of problem. (Example: Make sure that the computer is turned ON.) The Multi-Function station's scan application is not running correctly on the computer. Restart your computer and try again.
PCFAX	<ul style="list-style-type: none"> If the PC fax setting (feature #442) is set to "ALWAYS", <ul style="list-style-type: none"> check the connection between the computer and the unit. check that the computer is turned on.
PLEASE WAIT	<ul style="list-style-type: none"> The unit is warming up. Wait for a while.
POLLING ERROR	<ul style="list-style-type: none"> The other party's fax machine does not offer the polling function. Check with the other party.

DISPLAY MESSAGE	CAUSE AND REMEDY
REDIAL TIME OUT	<ul style="list-style-type: none"> The other party's fax machine is busy or has run out of recording paper. Try again.
REMOVE DOCUMENT	<ul style="list-style-type: none"> The document is jammed. Remove the jammed document. Attempted to send or copy a document longer than 600 mm using the automatic document feeder. Remove the document, and then press [Stop] to clear the message. Divide the document into two or more sheets and try again. The ADF top cover is not fully closed. Push firmly on the front and rear edges of the ADF top cover, and then feed the document again.
REMOVE PAPER IN INPUT TRAY #2	<ul style="list-style-type: none"> Recording paper is installed in the manual tray when trying to receive faxes or print reports. Remove the recording paper from the manual tray.
RX MEMORY FULL	<ul style="list-style-type: none"> The memory is full of received documents due to a lack of recording paper or a recording paper jam. Load paper or remove the jammed paper. If the PC fax (feature #442) is set to "ALWAYS", <ul style="list-style-type: none"> check the connection between the computer and the unit. check that the computer is turned ON. If the fax preview mode (feature #448) is set to "ON". <ul style="list-style-type: none"> view, print or save the received fax documents using the web browser on the computer connected via the LAN, and then erase the unnecessary documents. turn the setting to "OFF". The fax documents stored in memory will be printed automatically. Refer to Program Mode Table (P.177).
SLEEP	<ul style="list-style-type: none"> After the unit has been in power save mode (feature #403) for up to 5 minutes, the unit will enter sleep mode. Press any key to put the unit in standby for the next process. <p>Note:</p> <ul style="list-style-type: none"> The unit may not enter sleep mode when beeping for alert or displaying an error message.
TONER EMPTY	<ul style="list-style-type: none"> The toner is empty. Replace the toner cartridge immediately.
TONER LIFE LOW	<ul style="list-style-type: none"> The toner life is near to an end. Replace the toner cartridge as soon as possible.
TONER LIFE OVER	<ul style="list-style-type: none"> The toner cartridge has finished its service life. Replace the toner cartridge immediately.
TONER LOW	<ul style="list-style-type: none"> The toner is reaching the end of its life. You will need to replace the toner cartridge soon.
TRANSMIT ERROR	<ul style="list-style-type: none"> A transmission error occurred. Try again.
USB MEMORY ACCESS ERROR	<ul style="list-style-type: none"> The USB memory device was removed while being accessed for reading/writing. Insert the device and reperform the operation. A fault occurred while the USB memory device was being accessed for reading/writing. Using a computer, check that the device can be read and written to normally.
USB MEMORY FILE SIZE OVER	<ul style="list-style-type: none"> There is no space to save new data on the USB memory device. Erase unnecessary data using your computer. When performing scan to USB memory, the total number of scanned pages is exceeded the limitation. Divide the document into sections.
USB MEMORY FORMAT ERROR	<ul style="list-style-type: none"> The media is unformatted or is formatted to an unsupported format (e.g., NTFS). Using a computer, format to FAT32. Formatting deletes all data on the USB memory device. Make sure to back up your data before formatting.
USB MEMORY MEDIA ERROR	<ul style="list-style-type: none"> An unsupported USB memory device is connected. Devices with particular security features or hub features cannot be used.
USB MEMORY NOT INSERTED	<ul style="list-style-type: none"> The USB memory device has been removed from the unit. Reinsert it. There is no USB memory device inserted in the unit. Insert one.
USB MEMORY WRITE PROTECT	<ul style="list-style-type: none"> The write-protection switch of the USB memory device is in the lock position. Unlock the switch to allow writing access. The saving folder in the USB memory device is set to "read only". Using a computer, set the saving folder to "writable". (For details about the saving folder name specifications.)

Interface messages

DISPLAY MESSAGE	CAUSE AND REMEDY
CONNECT ERROR	<ul style="list-style-type: none"> • IP address of the server or network configuration is incorrect. Consult your network administrator. • The server is down. Consult your network administrator.
DATA ERROR	<ul style="list-style-type: none"> • The cable between the unit and the computer is not connected correctly. Check the connections. Refer to Installing software (including printer, scanner and other drivers) (P.129). Refer to Connections (P.131). • IP address of the server or network configuration is incorrect. Consult your network administrator. • Your computer may not have enough memory. Change to a lower resolution for scanning and try again. • The email server configuration requires authentication. Check the configuration of the email server. • SMB folder is read only. Consult your network administrator.
EMAIL SIZE OVER	<ul style="list-style-type: none"> • When performing scan to email address, the number of scanned pages or the file size of the scanned data has exceeded the limitation. Divide the document into sections. Refer to Specifications (P.11).
FILE SIZE OVER	<ul style="list-style-type: none"> • When performing scan to FTP server or scan to SMB folder, the number of scanned pages or the file size of the scanned data has exceeded the limitation. Divide the document into sections.
LOGIN ERROR	<ul style="list-style-type: none"> • Login name or password of the server is incorrect or you do not have permission to login to the server. Consult your network administrator.
NAME ERROR	<ul style="list-style-type: none"> • The server name is incorrect. Consult your network administrator. • The server is down. Consult your network administrator to activate the server.
OFFLINE	<ul style="list-style-type: none"> • The cable between the unit and the computer is not connected correctly. Check the connections. Refer to Installing software (including printer, scanner and other drivers) (P.129). Refer to Connections (P.131). • Check that the computer is turned ON.
PATH ERROR	<ul style="list-style-type: none"> • The path of FTP server or SMB folder is incorrect. Consult your network administrator.
PC ACCESS ERROR	<ul style="list-style-type: none"> • Check that the computer is turned ON. • The Multi-Function station's scan application is not running correctly on the computer. Restart your computer and try again. • If your computer is busy, close other applications. • Your firewall software is blocking the LAN connection. Disable the firewall software or change the firewall settings to allow the unit access to your computer.
PC FAIL OR BUSY	<ul style="list-style-type: none"> • The cable between the unit and the computer is not connected correctly. Check the connections. Refer to Installing software (including printer, scanner and other drivers) (P.129). Refer to Connections (P.131). • The computer has some kind of problem. (Example: Make sure that the computer is turned ON.). • The Multi-Function station's scan application is not running correctly on the computer. Restart your computer and try again.

12.2. Remote Programming

If, after the call is connected, the customer describes the situation and it is determined that the problem can be corrected by making parameter changes, this function makes it possible to change parameters such as the user code and service code from another fax (using DTMF tones). Therefore, travel to the customer's location is not required. However, it is not possible to change all the parameters remotely (**Program Mode Table**(P.177)). The function used to accomplish this is remote programming.

First, in order to check the current status of the service code parameter, print out the setup list (code: 991) and the service list (code: 999) from the customer's fax machine.

Based on this, the parameters for the desired codes can be changed.

The procedure for changing and listing parameters is described on **Entering the Remote Programming Mode and Changing Service Codes**(P.176). Also, before exiting the remote programming mode, it is advisable to obtain a new list to confirm that the changes were made correctly.

Hint:

Since the connected telephone is in use during the remote programming mode, it may be helpful to ask the customer to switch to the speakerphone. This frees the customer from the need to remain right next to the fax while you are making parameter settings. When finished, inform the customer. Also note that in very noisy locations where the DTMF tones are not audible, the remote programming function will not work.

12.2.1. Entering the Remote Programming Mode and Changing Service Codes

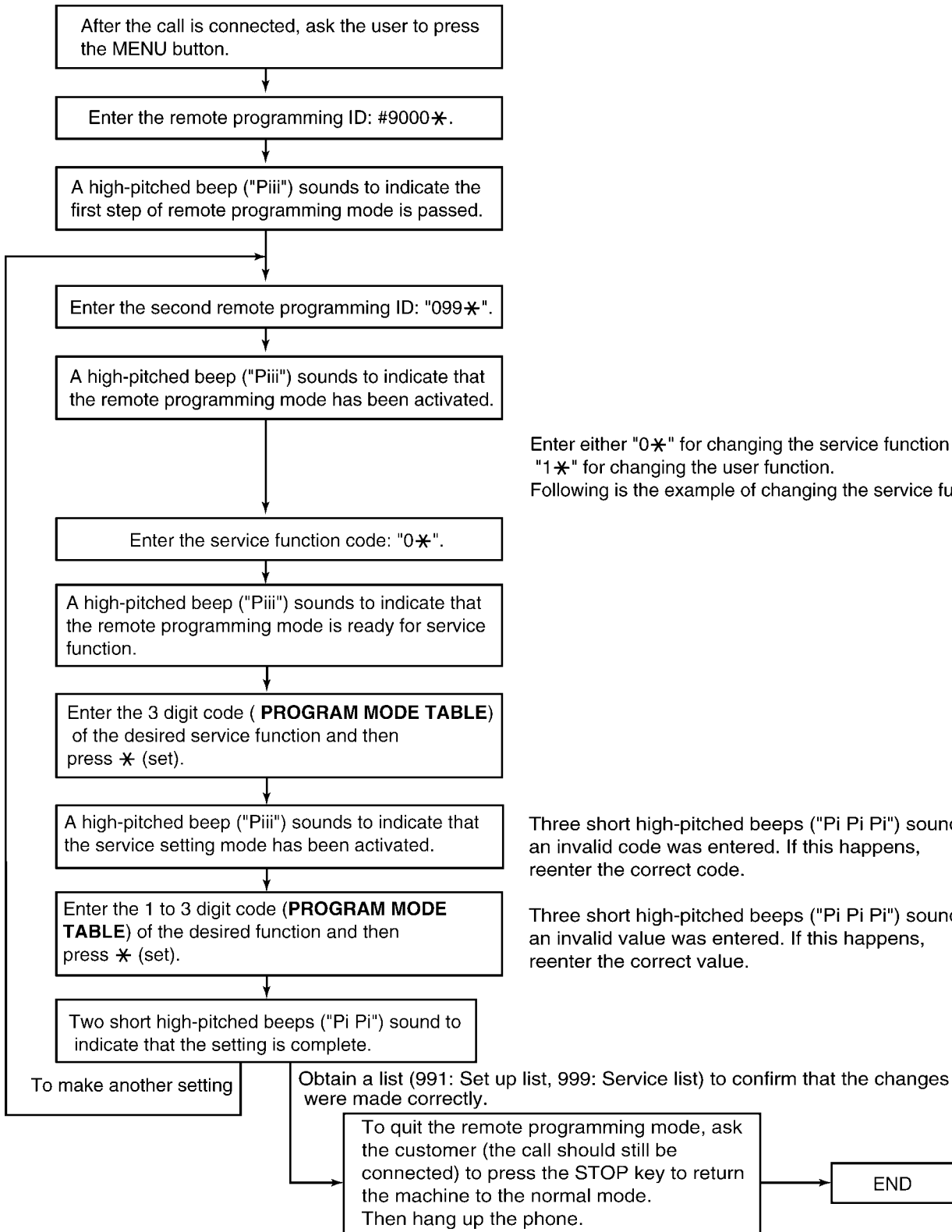

CROSS REFERENCE:
Program Mode Table (P.177)

12.2.2. Program Mode Table

12.2.2.1. User Function

Basic features

Code	Function	Set Value	Default	Remote Setting
101	SET DATE & TIME*1	dd/mm/yy hh:mm	01/01/13 00:00	NG
102	YOUR LOGO*2	-----	None	NG
103	YOUR FAX NUMBER*2	-----	None	NG
110	LANGUAGE	1:ENGLISH / 2:CZECH / 4:FRENCH / 5:GERMAN / 6:HUNGARIAN / 7:POLLISH / 8:PORTUGUESE / 9:SLOVAK / 10:SPANISH / 11:TURKISH	ENGLISH	OK
114	LOCATION	1:BELGIUM / 2:CZECH / 3:EUR.STANDARD / 4:FRANCE / 5:GERMANY / 6:HUNGARY / 7:NETHERLANDS / 8:POLAND / 9:PORTUGAL / 10:SLOVAKIA / 11:SPAIN / 12:U.K.	GERMANY	OK
120	DIALLING MODE*2	1:PULSE / 2:TONE	TONE	OK
121	SET FLASH TIME*2	90:900 / 70:700 / 60:600 / 40:400 / 30:300 / 25:250 / 20:200 / 16:160 / 11:110 / 10:100 / 9:90 / 8:80 (ms)	100ms	OK
124	ADSL MODE*2	0:OFF / 1:ON	OFF	OK
145	LCD CONTRAST (KX-MB25**, DP-MB310 ONLY)	1:NORMAL / 2:DARKER	NORMAL	NG
145	LCD CONTRAST (KX-MB25**, DP-MB310 ONLY)	1:-2 , 2:-1, 3:0, 4:1, 5:2	0	NG
147	SCALE	1:MILLIMETRES / 2:INCHES	MILLIMETRES	OK
148	DISPLAY INTERVAL	1:1sec, 2:2sec, 3:3sec, 4:4sec, 5:5sec	1sec	OK
151	ADMIN CODE	-	DEFAULT=0000	NG
154	MODE RESTRICTION	0:OFF / 1:ON	OFF	NG
155	CHANGE PASSWORD	-----	DEFAULT=1234	NG
158	MAINTENANCE TIME	-----	00:00	NG
159	RESTORE DEFAULT	0:NO / 1:YES	NO	NG
161	RINGER PATTERN*2	1:A / 2:B / 3:C	A	NG
165	BEEP SOUND	0:OFF / 1:ON	ON	OK
174	JOB END NOTIFY	0:OFF / 1:ON	OFF	OK
210	FAX RING COUNT*2	1 to 9 rings (for ext. tam)	2	OK
289	ERASE ADDR. BOOK	0:NO / 1:YES	NO	NG
380	PAPER SIZE #1	1:LETTER / 2:A4 / 3:LEGAL / 4:B5(ISO) / 5:B5(JIS) / 6:16K / 7:216x330 / 8:216x340 / 10:A5 Note*1	A4	OK
381	PAPER SIZE #2	1:LETTER / 2:A4 / 3:LEGAL / 4:B5(ISO) / 5:B5(JIS) / 6:16K / 7:216x330 / 8:216x340 / 9:A6 / 10:A5 / 11:B6(ISO) / 12:B6(JIS) Note*1	A4	OK
382	PAPER SIZE #3 (KX-MB25**,DP-MB310 ONLY)*3	1:LETTER / 2:A4 / 3:LEGAL / 4:B5(ISO) / 5:B5(JIS) / 6:16K / 7:216x330 / 8:216x340 / 10:A5 Note*1	A4	OK
383	MEDIA TYPE #1	1:PLAIN PAPER / 2:THIN PAPER	PLAIN PAPER	OK
384	MEDIA TYPE #2	1:PLAIN PAPER / 2:THIN PAPER / 3:THICK PAPER	PLAIN PAPER	OK
385	MEDIA TYPE #3 (KX-MB25**,DP-MB310 ONLY)*3	1:PLAIN PAPER / 2:THIN PAPER	PLAIN PAPER	OK
390	LIST PRINT TRAY (KX-MB25**,DP-MB310 ONLY)*3	1:#1 / 3:#3 / 4:#1+#3	#1	NG
403	POWER SAVE	1:1min / 5:5min / 15:15min / 30:30min / 45:45min	1min	OK
462	CONTRAST HOLD	0:DISABLED / 1:ENABLED	DISABLED	OK
463	DEFAULT MODE*2	1:COPY / 2:FAX	COPY	OK
464	MODE TIMER*2	0:OFF / 1:30S / 2:1min / 3:2min / 4:5min	1min	OK
479	DEPT. COUNT VIEW	-	-	NG
482	TONER SAVE	0:OFF / 1:ON	OFF	OK
484	COUNTER VIEW	-	-	NG

*1 Only for models that support the fax feature or LAN connection.

*2 Only for models that support the fax feature.

*3 Only for models that support the lower input tray.

Fax features (KX-MB2230/KX-MB2545/KX-MB2575/DP-MB310 ONLY)

Code	Function	Set Value	Default	Remote Setting
212	TEL/FAX DELAYED RING	1~9	2	OK
319	REMOTE TURN ON	0:OFF / 1:ON	OFF	
401	PRINT SENDING REPORT	0:OFF / 1:ON / 2:ERROR	ERROR	OK
402	JOURNAL AUTO PRINT	0:OFF / 1:ON	ON	OK
404	MANUAL ANSWER MODE	1:TEL / 2:TEL/FAX	TEL	OK
405	FAX RESOLUTION	1:STANDARD / 2:FINE / 3:SUPER FINE / 4:PHOTO	STANDARD	OK
407	FAX DUPLEX PRINT	0:OFF / 1:LONG EDGE / 2:SHORT EDGE	OFF	OK
411	OVERSEAS MODE	0:OFF 1: / NEXT FAX / 2:ERROR	ERROR	OK
412	DELAYED TRANSMISSION	0:OFF / 1:ON	OFF	NG
413	ECM SELECTION	0:OFF / 1:ON	ON	OK
416	CONNECTING TONE	0:OFF / 1:ON	ON	OK
418	MAX FAX SPEED	1:14.4Kbps / 2:33.6Kbps	33.6Kbps	OK
419	QUICK SCAN MODE	0:OFF / 1:ALWAYS	OFF	OK
420	CONFIRM FAX NO.	0:OFF / 1:ON	OFF	OK
421	RESTRICT FAX NO.	0:OFF / 1:ON	OFF	OK
422	RE-ENTER FAX NO.	0:OFF / 1:ON	OFF	OK
424	CONFIRM NEXT DOC	0:OFF / 1:ON	OFF	OK
425	DIRECT SMTP XMT (KX-MB25**,DP-MB310 ONLY)	0:OFF / 1:ON	OFF	OK
426	DELIVERY NOTICE (KX-MB25**,DP-MB310 ONLY)	0:OFF / 1:ON	ON	OK
428	POP TIMER (KX-MB25**,DP-MB310 ONLY)	0~60(min)	3min	NG
432	AUTO REDUCTION	0:OFF / 1:ON	ON	OK
434	FAX ACTIVATION CODE	ON / OFF	ON CODE=#9	NG
436	SILENT FAX RING SETTING	3~9	3	OK
437	MEMORY RECEIVE ALERT	0:OFF / 1:ON	ON	OK
438	FRIENDLY RECEPTION	0:OFF / 1:ON	ON	OK
440	FAX INPUT TRAY (KX-MB25**,DP-MB310 ONLY)	1:#1 / 3:#3 / 5:AUTO	AUTO	OK
442	PCFAX SETTING	0:OFF / 1:ALWAYS / 2:CONNECTED	CONNECTED	OK
443	PCFAX RCV PC	-	-	NG
448	PREVIEW MODE	0:OFF / 1:ON	OFF	NG
450	WEB FAX PREVIEW	-	-	NG
451	RECEIVE NOTIFY	0:OFF / 1:ON	OFF	OK
452	FAX AUTO EMAIL	0:OFF / 1:ON	OFF	OK
458	ERASE FAX MEMORY	0:NO / 1:YES	NO	NG
459	SET FAX DEFAULT	0:NO / 1:YES	NO	NG

Copy features

Code	Function	Set Value	Default	Remote Setting
460	COPY INPUT TRAY (KX-MB22** ONLY)	1:#1 / 2:#2	#1	NG
460	COPY INPUT TRAY (KX-MB25**, DP-MB310 ONLY)	1:#1 / 2:#2 / 3:#3 / 4:#1+#2+#3 / #1+#2 / #1+#3 or #2+#3	#1	NG
461	COPY RESOLUTION	1:TEXT/PHOTO / 2:TEXT / 3:PHOTO	TEXT/PHOTO	OK
467	PAGE LAYOUT HOLD	0:DISABLED / 1:ENABLED	DISABLED	OK
468	ZOOM HOLD	0:DISABLED / 1:ENABLED	DISABLED	OK
469	COLLATE HOLD	0:DISABLED / 1:ENABLED	DISABLED	OK
470	DUPLEX HOLD	0:DISABLED / 1:ENABLED	DISABLED	OK
473	EDGE HOLD	0:DISABLED / 1:ENABLED	DISABLED	OK
474	FRAME MARGIN	0:DISABLED / 1:ENABLED	DISABLED	OK
475	MARGIN HOLD	0:DISABLED / 1:ENABLED	DISABLED	OK

PC print features

Code	Function	Set Value	Default	Remote Setting
774	DATA TIMEOUT	5~600s	60s	NG
776	MUTUAL A4/LETTER	1:OFF / 2:ON	ON	OK

PC print features (KX-MB2515/KX-MB2545/KX-MB2575/DP-MB310 ONLY)

Code	Function	Set Value	Default	Remote Setting
760	PCL PAPER SOURCE	1:#1 / 2:#2 / 3:#3 / 4:#1+#2+#3 / #1+#2 / #1+#3 or #2+#3	#1	NG
762	PCL COPIES	1~999	1	NG

Code	Function	Set Value	Default	Remote Setting
763	PRINT FORMAT	1:LETTER / 2:A4 / 3:LEGAL / 4:B5(ISO) / 5:B5(JIS) / 6:16K / 7:216x330 / 8:216x340 / 9:A6 / 10:A5 / 11:B6(ISO) / 12:B6(JIS) Note*1	A4	OK
764	IMAGE REDUCTION	0:OFF / 1:ON	ON	OK
765	PCL ORIENTATION	1:PORTRAIT / 2:LANDSCAPE	PORTRAIT	OK
766	A4 WIDE	0:OFF / 1:ON	OFF	OK
767	LINES PER PAGE	5~128	64	NG
768	FONT SOURCE	1:RESIDENT / 2:DOWNLOAD FONT	RESIDENT	NG
769	FONT NUMBER	0~54	0	NG
770	FONT PITCH / POINT	0.44~99.99	10.00	NG
771	SYMBOL SET	-----	PC-8	NG
772	CR/LF/FF	1:CR/LF/FF / 2:CR+LF/LF/FF / 3:CR/CR+LF/CR+FF	CR/LF/FF	NG
773	AUTO CONTINUE	1:OFF / 2:20s / 3:30s / 4:60s / 5:90s / 6:120s	OFF	OK

Scan features

Code	Function	Set Value	Default	Remote Setting
493	SCAN MODE	1:VIEWER / 2:FILE / 3:EMAIL / 4:OCR / 5:EMAIL ADDRESS / 6:FTP SERVER / 7:SMB FOLDER	VIEWER	OK
494	SCAN PARAM. HOLD	0:DISABLED / 1:ENABLED	DISABLED	OK

LAN features (KX-MB2230/KX-MB2515/KX-MB2545/DP-MB310 ONLY)

Code	Function	Set Value	Default	Remote Setting
500	DHCP	0:DISABLED / 1:ENABLED	ENABLED	OK
501	IP ADDRESS	-----	-----	NG
502	SUBNET MASK	-----	-----	NG
503	DEFAULT GATEWAY	-----	-----	NG
504	DNS SERVER #1	-----	-----	NG
505	DNS SERVER #2	-----	-----	NG
507	MACHINE NAME	-----	-----	NG
508	MAC ADDRESS	-----	-----	NG
513	BONJOUR	0:DISABLED / 1:ENABLED	ENABLED	OK
526	NETWORK STATUS	-----	-----	NG
532	IP FILTERING	0:DISABLED / 1:ENABLED	DISABLED	OK
533	AUTO IP	0:DISABLED / 1:ENABLED	DISABLED	OK
534	HTTPD	0:DISABLED / 1:ENABLED	ENABLED	OK
535	IPv6 PROTOCOL	0:DISABLED / 1:ENABLED	DISABLED	OK
538	WINS SERVER #1	-----	-----	NG
539	WINS SERVER #2	-----	-----	NG
567	ADDRESS ON WEB	0:DISABLED / 1:ENABLED	ENABLED	OK
569	JOURNAL ON WEB (KX-MB2230 / KX-MB2545 / DP-MB310 ONLY)	0:DISABLED / 1:ENABLED	ENABLED	OK
578	ERASE ADDRESS	0:NO / 1:YES	NO	NG
580	LAN MODE	0:OFF / 1:WIRED	WIRED	NG

LAN features (KX-MB2270/KX-MB2575 ONLY)

Code	Function	Set Value	Default	Remote Setting
500	DHCP	0:DISABLED / 1:ENABLED	ENABLED	OK
501	IP ADDRESS	-----	-----	NG
502	SUBNET MASK	-----	-----	NG
503	DEFAULT GATEWAY	-----	-----	NG
504	DNS SERVER #1	-----	-----	NG
505	DNS SERVER #2	-----	-----	NG
507	MACHINE NAME	-----	-----	NG
508	MAC ADDRESS	-----	-----	NG
513	BONJOUR	0:DISABLED / 1:ENABLED	ENABLED	OK
526	NETWORK STATUS	-----	-----	NG
532	IP FILTERING	0:DISABLED / 1:ENABLED	DISABLED	OK
533	AUTO IP	0:DISABLED / 1:ENABLED	DISABLED	OK
534	HTTPD	0:DISABLED / 1:ENABLED	ENABLED	OK
535	IPv6 PROTOCOL	0:DISABLED / 1:ENABLED	DISABLED	OK

Code	Function	Set Value	Default	Remote Setting
538	WINS SERVER #1	-----	-----	NG
539	WINS SERVER #2	-----	-----	NG
567	ADDRESS ON WEB	0:DISABLED / 1:ENABLED	ENABLED	OK
569	JOURNAL ON WEB	0:DISABLED / 1:ENABLED	ENABLED	OK
578	ERASE ADDRESS	YES / NO	NO	NG
580	LAN MODE	0:OFF / 1:WIRED (/ 2:WIRELESS)	WIRED	NG
581	WIRELESS STATUS	-	-	NG
582	WPS-PBC	-	-	NG
583	WPS-PIN	-	-	NG
584	SSID SEARCH	-	-	NG
585	CONFIGURATION	-	-	NG
586	WIRELESS RESTORE	-	-	NG

USB Print features (KX-MB2515/MB2545/KX-MB2575/DP-MB310 ONLY)

Code	Function	Set Value	Default	Remote Setting
660	USB PRINT COPIES	1~99	1	NG
661	ORIENTATION	1:PORTRAIT / 2:LANDSCAPE	PORTRAIT	OK
662	USB PRINT N in 1	0:OFF / 1:2 in 1 / 2:4 in 1 / 3: 8 in 1	OFF	OK
663	Nin1 PAGE BORDER	0:NONE / 1: SOLID LINE	NONE	OK
664	USB PRINT DUPLEX	0:OFF / 1:LONG EDGE / 2:SHORT EDGE	OFF	OK
665	CONTINUOUS PRINT	0:DISABLED / 1:ENABLED	ENABLED	OK
669	PRINT INPUT TRAY	1:#1 / 2:#2 / 3:#3 / 4:#1+#2+#3 / #1+#2 / #1+#3 or #2+#3	#1	NG
672	DISPLAY SORT	0:OFF / 1:NAME ORDER / 2:DATE ORDER	DATE ORDER	OK

OK means "can set".

NG means "can not set".

Note:

*1 Choices "7:216 x 330 / 8:216 x 340" change to Inch display when "INCHES" is set on feature #147 setting.

Example:

If you want to set value in the "401 PRINT SENDING REPORT", press the dial key number 1, 2 or 3 corresponding to the Set Value you want to select. (1:ERROR/2:ON/3:OFF)

12.2.2.2. Service Function

Code	Function	Set Value	Default	Remote Setting
501	Pause time set	001~600 x 100msec	030	OK
503	Dial speed	1:10pps / 2:20pps	10pps	OK
507	V34 transmission start speed	0:Disable / 1:33.6 / 2:31.2 / 3:28.8 / 4:26.4 / 5:24.0 / 6:21.6 / 7:19.2 / 8:16.8	33,600bps	OK
508	V34 reception start speed	0:Disable / 1:33.6 / 2:31.2 / 3:28.8 / 4:26.4 / 5:24.0 / 6:21.6 / 7:19.2 / 8:16.8	33,600bps	OK
514	Bell signal detect time	1~9 x 100msec	3	OK
520	CED frequency select	1:2,100Hz / 2:1,100Hz	2,100	OK
521	International mode select	1:ON / 2:OFF	ON	OK
522	Auto standby select	1:ON / 2:OFF	ON	OK
523	Receive equalizer select	1:0kms / 2:1.8km / 3:3.6km / 4:7.2km	0km	OK
524	Transmission equalizer select	1:0kms / 2:1.8km / 3:3.6km / 4:7.2km	0km	OK
527	V8 function select	1:OFF / 2:ON	ON	OK
529	Memory clear for Call Service	-----	-----	NG
550	Memory clear	-----	-----	NG
551	ROM check	-----	-----	NG
552	DTMF signal tone test	1:ON / 2:OFF	OFF	OK
553	Monitor on FAX communication select	1:OFF / 2:Phase B / 3:ALL	OFF	OK
554	Modem test	-----	-----	NG
555	Scanner test	-----	-----	NG
556	Motor test	-----	-----	NG
557	LED test	-----	-----	NG
558	LCD test	-----	-----	NG
561	KEY test	-----	-----	NG
565	Irregular data set	1:Non_delete 2:delete	1	OK
567	T0 timer	001~255sec	052	OK
570	Break% select	1:61% / 2:67% / 3:63%	61%	OK
573	Remote turn-on ring number set	00~99	15	OK
574	Dial tone detect check	1:ON / 2:OFF	OFF	OK
590	FAX auto redial time set	00~99	05	OK
591	FAX auto redial line disconnection time set	001~999sec	65	OK
592	CNG transmit select	1:OFF / 2:ALL / 3:AUTO	ALL	OK
593	Time between CED and 300bps	1:75ms / 2:500ms / 3:1sec	75ms	OK
594	Overseas DIS detection select	1:1st / 2:2nd	1st	OK
595	Receive error limit value set	1:5% / 2:10% / 3:15% / 4:20%	10%	OK
596	Transmit level set	-15~00dBm	10	OK
598	Receiving Sensitivity	20~48	48	OK
599	ECM Frame size	1:256 / 2:64	256byte	OK
628	H.V.P.S check	-----	-----	NG
639	LSU test	-----	-----	NG
655	Cause distinction code of call service 3	-----	-----	NG
677	FAN test	-----	-----	NG
710	Memory clear except history data	-----	-----	NG
711	Dialing mode	1:PULSE / 2:TONE	TONE	OK
717	Transmit speed select	1:14,400bps / 2:12,000bps / 3:9,600bps / 4:7,200bps / 5:4,800bps / 6:2,400bps	14,400bps	OK
718	Receive speed select	1:14,400bps / 2:12,000bps / 3:9,600bps / 4:7,200bps / 5:4,800bps / 6:2,400bps	14,400bps	OK
721	Pause tone detect	1:ON / 2:OFF	OFF	OK
722	Redial tone detect	1:ON / 2:OFF	ON	OK
763	CNG detect time for friendly reception	1:10s / 2:20s / 3:30s	30s	OK
774	Receiving T4 timer	00~99 x 100msec	00	OK
775	Transmission T4 timer	00~99 x 100msec	00	OK
796	Attach sending image to sending report	1:ON / 2:OFF	1	OK
815	Sensor check	-----	-----	NG
852	Print test pattern	-----	-----	NG
853	Top margin	1~11 x 0.5mm	6	OK
854	Left margin	1~11 x 0.5mm	6	OK
856	Top margin (Duplex)	1~11 x 0.5mm	6	OK
870	Left margin (OPF)	1~11 x 0.5mm	6	OK
871	Left margin (Duplex)	1~11 x 0.5mm	6	OK
874	DTMF ON time	060~200msec	100	OK
875	DTMF OFF time	060~200msec	100	OK

Code	Function	Set Value	Default	Remote Setting
880	History list	-----	-----	NG
881	Journal 2	-----	-----	NG
882	Journal 3	-----	-----	NG
991	Setup list	1:Start	-----	OK
994	Journal list	1:Start	-----	OK
995	Journal 2 list	1:Start	-----	OK
996	Journal 3 list	1:Start	-----	OK
998	History list	1:Start	-----	OK
999	Service list	1:Start	-----	OK

OK means "can set".

NG means "can not set".

Note:

Refer to **Service Function Table** (P.142) for descriptions of the individual codes.

Example:

If you want to set value in the "401 PRINT SENDING REPORT", press the dial key number 1, 2 or 3 corresponding to the Set Value you want to select. (1:ERROR/2:ON/3:OFF)

12.3. Troubleshooting Details

12.3.1. Outline

Troubleshooting is for recovering quality and reliability by determining the broken component and replacing, adjusting or cleaning it as required. First, determine the problem then decide the troubleshooting method. If you have difficulty finding the broken part, determine which board is broken. (For example: the Main PCB, Sensor PCB, etc.) The claim tag from a customer or dealer may use different expressions for the same problem, as they are not a technician or engineer. Using your experience, test the problem area corresponding to the claim. Also, returns from a customer or dealer often have a claim tag. For these cases as well, you need to determine the problem. Test the unit using the simple check list on **Simple Check List**(P.184). Difficult problems may be hard to determine, so repeated testing is necessary.

12.3.2. Starting Troubleshooting

Determine the symptom and the troubleshooting method.

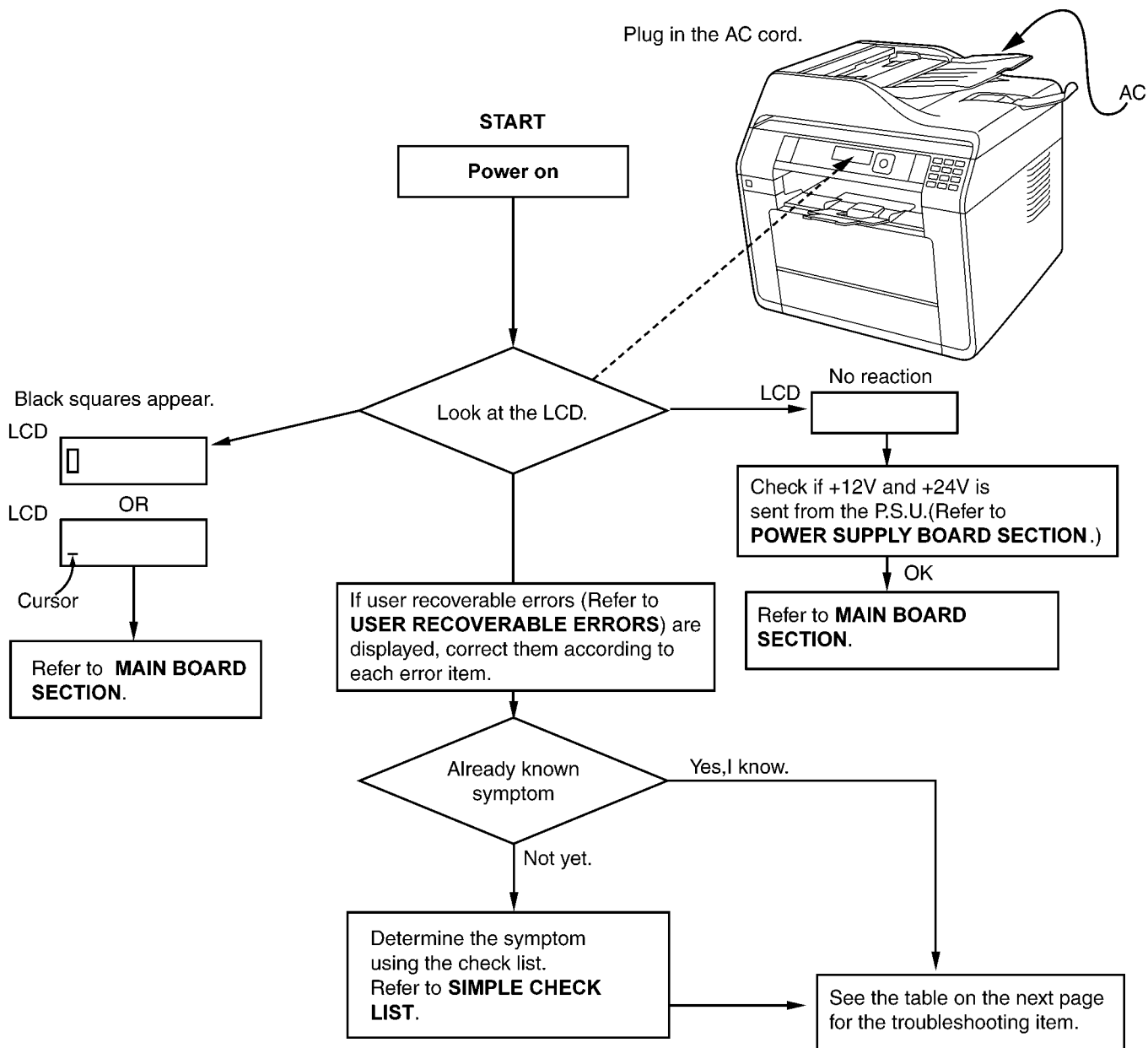

CROSS REFERENCE:

- Simple Check List (P.184)
- User Recoverable Errors (P.171)
- Main Board Section (P.333)
- Power Supply Board Section (P.106)

12.3.3. Simple Check List

SERIAL NO. _____

DATE _____

FUNCTION		JUDGEMENT	REFERENCE
FAX operation (except KX-MB2*1*)	Transmission	OK / NG	
	Receiving	OK / NG	
Copy operation	Copy by Flat Bed	OK / NG	
	Copy by ADF	OK / NG	
PC operation	USB PC print	OK / NG	
	LAN PC Scan (Color)	OK / NG	
Telephone operation (except KX-MB2*1*)	MONITOR sound	OK / NG	
	Ringer sound	OK / NG	
	Dial operation	OK / NG	
	Volume operation	OK / NG	
Operation panel	Key check	OK / NG	Service code 561※
	LED check	OK / NG	Service code 557※
	LCD check	OK / NG	Service code 558※
Sensor	Sensor check	OK / NG	Service code 815※
Clock		OK / NG	Is the time kept correctly? Check with another clock.

Note:Check according to the service code referring to **Test Functions** (P.136).

12.3.4. Simplified Troubleshooting Guide

12.3.4.1. Printing

No.	Symptom	Cause	Countermeasure
1	Ghost Image (P.197)	Failed drum cartridge	Replace drum cartridge
		Failed transfer unit	Check the transfer roller and spring
		Failed the high-voltage terminal	Check the high-voltage terminal
		Failed the high voltage power supply board	Go to High Voltage Section (P.251)
		Failed fuser unit	Check the heat roller and the pressurized roller and the spring and the heat lamp and the thermistor
		Too thick or too thin recording paper	Use the recording paper from 16lb to 24lb
2	Dark or White Vertical Line (P.198)	Dirty the reflecting mirror	Clean the reflecting mirror
		Dust on the path of the laser beam	Clean the path of the laser beam
		Failed drum cartridge	Replace drum cartridge
		Failed the heat roller or the pressurized roller	Check the heat roller and the pressurized roller
		Failed LSU	Go to LSU (Laser Scanning Unit) Section (P.75)
3	Dark or White Horizontal Line (P.199)	Failed drum cartridge	Replace drum cartridge
		Failed the gear	Check the gear
		Failed the Main motor	Check the motor
		Failed the high-voltage terminal	Check the high-voltage terminal
		Failed the high voltage power supply board	Go to High Voltage Section (P.251)
		Scratch on the OPC drum	Replace drum cartridge
		Static electricity on the documents (when copying)	Check the connection between the parts around CIS and earth
4	Dirty or Half Darkness Background (P.200)	Failed drum cartridge	Replace drum cartridge
		Dirty the pickup roller and the regist roller and the feed roller and the eject roller and the heat roller and the pressure roller	Clean the pickup roller and the regist roller and the feed roller and the eject roller and the heat roller and the pressure roller
		Failed the high-voltage terminal	Check the high-voltage terminal
		Failed the high voltage power supply board	Go to High Voltage Section (P.251)
		Dirty the recording paper path	Clean the recording paper path
5	Black Print (P.201)	Failed drum cartridge	Replace drum cartridge
		Failed LSU	Go to LSU (Laser Scanning Unit) Section (P.75)
		Failed the high-voltage terminal	Check the high-voltage terminal
		Failed the high voltage power supply board	Go to High Voltage Section (P.251)
		Failed the main board	Go to Main Board Section (P.34)
		Failed CIS (when copying)	Go to CIS Control Section (P.248)
6	Black Print (P.201) OR Light Print (P.202)	Short toner	Supply toner
		Failed drum cartridge	Replace drum cartridge
		Life of drum cartridge is over	Replace drum cartridge
		Dirty the reflecting mirror	Clean the reflecting mirror
		Failed the high-voltage terminal	Check the high-voltage terminal
		Failed the high voltage power supply board	Go to High Voltage Section (P.251)
		Failed the main board	Go to Main Board Section (P.34)
		Failed CIS (when copying)	Go to CIS Control Section (P.248)
7	Black or White Point (P.203)	Failed the developer roller (32mm pitch)	Replace toner cartridge
		Failed the OPC drum (75mm pitch)	Replace drum cartridge
		Failed the heat roller (79mm pitch)	Check the heat roller
		Failed the high voltage power supply board	Go to High Voltage Section (P.251)
		Too thick or too thin recording paper	Use the recording paper from 16lb to 24lb

12.3.4.2. Recording Paper Feed

No.	Symptom	Cause	Countermeasure
1	Multiple Feed (P.203)	Dirty or failed the pickup roller	Clean or replace the pickup roller
		Dirty or failed the pickup rubber	Clean or replace the separation rubber
2	The Recording Paper Is Waved or Wrinkled (P.204)	Dirty the pressure roller or the heat roller	Clean the pressure roller and the heat roller
		Failed the spring of pressure roller	Replace the spring of pressure roller
		Separator of heat roller a check	Replace separator
		Dust on the recording paper path	Clean the recording paper path
		Too thin recording paper	Use the recording paper from 16lb to 24lb
3	Skew (P.205)	Dirty or failed the pickup roller	Clean or replace the pickup roller
		Dirty or failed the pickup rubber	Clean or replace the separation rubber
		Dirty or failed the paper feed roller	Clean or replace the regist roller
		Dust on the recording paper path	Clean the recording paper path
		Failed LSU	Replaced LSU
		Over the max capacity of the recording paper	Set up to MAX 250 sheets
		Too thick or too thin recording paper	Use the recording paper from 16lb to 24lb
4	The Recording Paper Does Not Feed (P.206)	Dirty or failed the pickup roller	Clean or replace the pickup roller
		Dirty or failed the pickup rubber	Clean or replace the separation rubber
		Failed the gear	Check the gear
		Failed the solenoid	Check the solenoid
		Failed the main motor	Go to Motor Section (P.244)
		Failed the pickup sensor lever	Check the pickup sensor lever
		Failed the pickup sensor	Go to Sensor Section (P.237)
5	The Recording Paper Jam (P.207) "PAPER JAMMED" ON THE LCD	Dirty or failed the pressure roller	Clean or replace the pressure roller
		Dirty or failed the heat roller	Clean or replace the heat roller
		Failed the separator of heat roller	Replace separator
		Dust on the recording paper path	Clean the recording paper path
		Failed the paper feed roller	Replace the registration roller
		Failed the pickup sensor lever	Check the pickup sensor lever
		Failed the pickup sensor	Go to Sensor Section (P.237)
		Failed the registration sensor lever	Check the Registration & Manual paper sensor (paper top sensor) lever
		Failed the registration sensor	Go to Sensor Section (P.237)
		Failed the exit sensor	Check the Paper Exit sensor lever
6	Back Side of The Recording Paper is Dirty (P.208)	Too thick or too thin recording paper	Use the recording paper from 16lb to 24lb
		Dirty the recording paper path	Clean the recording paper path
		Dirty the pressure roller	Clean the pressure roller
		Dirty the regist roller	Clean the registration roller
		Failed the high-voltage terminal	Check the high-voltage terminal
		Failed the high voltage power supply board	Go to High Voltage Section (P.251)

12.3.4.3. Copy and FAX

No.	Symptom	Cause	Countermeasure
1	No Document Feed (No Document Feed, Document JAM and Multiple Document Feed) (P.209)	Failed the document sensor lever	Replace the document sensor lever
		Failed the document sensor	Go to Sensor Section (P.237)
		Dirty or failed the separation roller	Clean or replace the separation roller
		Dirty or failed the separation rubber	Clean or replace the separation rubber
		Failed the separation spring	Replace the separation spring
		ADF top cover is not fully closed.	Push firmly on front and rear edges of the ADF top cover.
	Document JAM (No Document Feed, Document JAM and Multiple Document Feed) (P.209)	Dust or scratch on the document paper path	Clean the document paper path
		Failed the gear	Check the gear
		Failed the ADF motor	
	Multiple Document Feed (No Document Feed, Document JAM and Multiple Document Feed) (P.209)	Dirty or failed the separation roller	Clean or replace the separation roller
Dirty or failed the separation rubber		Clean or replace the separation rubber	
Failed the separation spring		Replace the separation spring	
2	Skew (ADF) (P.211)	Dust or scratch on the document paper path	Clean the document paper path
		Failed the document feed roller	Replace the document feed roller
		Failed the document guide	Replace the document guide
3	Scanner Glass (P.212)	Failed CIS unit holder	Replace CIS unit holder
4	The Sent FAX Data is Skewed (P.212)	The cause of ADF	Go to Skew (ADF) (P.211)
		The cause of scanner glass	----
		Problem with the other FAX machine	
5	The Received FAX Data is Skewed (P.212)	The cause of printing	Go to Skew (ADF) (P.211)
		Problem with the other FAX machine	
6	The Received or Copied Data is Expanded (P.213)	Dirty or failed the drive roller (at ADF)	Clean or replace the drive roller
		Dirty or failed the separation roller (at ADF)	Clean or replace the separation roller
		Failed CIS movement (at SG)	Replace the belt or the gear or the shaft or the ADF motor
7	Black or White Vertical Line is Copied (P.213)	Dirty or failed the white plate (2 places)	Clean or replace the white plate
		Dirty or failed the glass board	Clean or replace the glass board
		The cause of printing	Go to Dark or White Vertical Line (P.198)
		Failed CIS	Go to CIS Control Section (P.248)
8	An Abnormal Image is Copied (P.214)	Dirty or failed the white plate (2 places)	Clean or replace the white plate
		Dirty or failed the glass board	Clean or replace the glass board
		Dirty or failed the drive roller (at ADF)	Clean or replace the drive roller
		Dirty or failed the document feed roller (at ADF)	Clean or replace the document feed roller
		Dirty or failed the separation roller (at ADF)	Clean or replace the separation roller
		Failed CIS movement (at SG)	Replace the belt or the gear or the shaft or the ADF motor
		Failed CIS	Go to CIS Control Section (P.248)
		The cause of printing	Go to Dark or White Vertical Line (P.198)

12.3.5. CALL SERVICE Troubleshooting Guide

There are 8 kinds of Call Service messages.

	Display message	Error Point	When the power is OFF, message disappears.	Service mode
12.3.5.1.	Call Service 1	Polygon in LSU	Yes	*639
12.3.5.2.	Call Service 2	Laser in LSU	Yes	*639
12.3.5.3.	Call Service 3	Fuser	No	*655
12.3.5.4.	Call Service 4	FAN motor	Yes	*677
12.3.5.5.	Call Service 5	DC motor	Yes	*556
12.3.5.6.	Call Service 6	HVPS	Yes	*628
12.3.5.7.	Call Service 17	OPC first use detection	Yes	-
12.3.5.8.	Call Service 22	Toner first use detection	Yes	-

12.3.5.1. CALL SERVICE 1

"CALL SERVICE 1" means that the polygon motor inside the LSU does not rotate.
 The rotation of the polygon motor is detected by IC300-H25pin (NREADY).

After the LCD indicates "CALL SERVICE 1", turn the power OFF/ON.
 Then, when the unit starts initial operation, confirm that the rotating sound of the polygon motor is heard before the engine motor starts to run.

* You can check the LSU function by service mode ✕639.

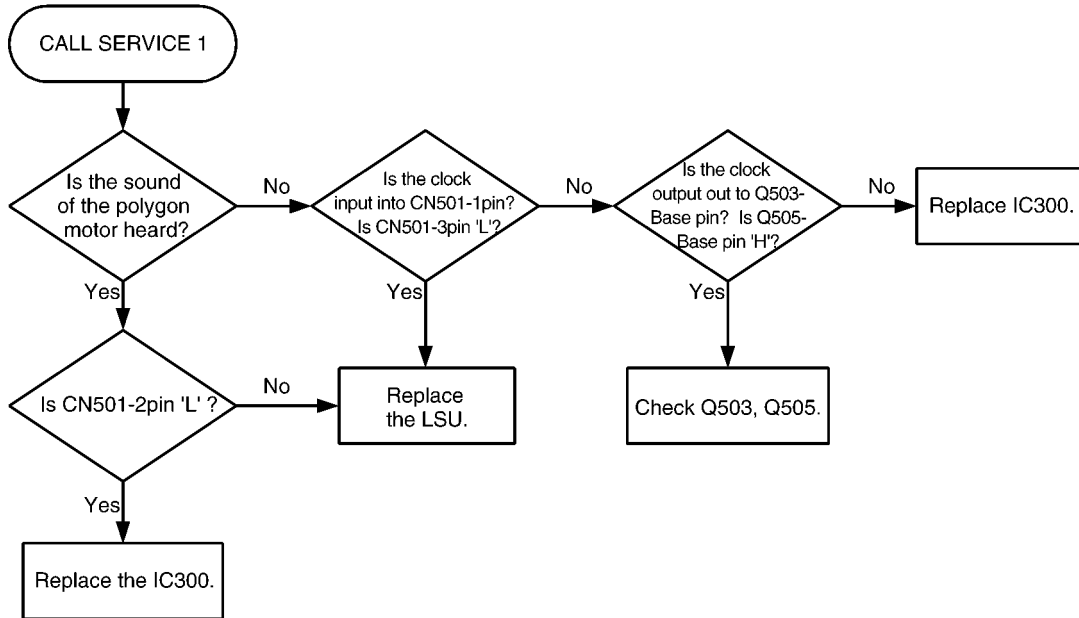

Note:

Refer to LSU (Laser Scanning Unit) Section (P.75) for technical description.

12.3.5.2. CALL SERVICE 2

"CALL SERVICE 2" means that the synchronous signal out of the LSU cannot be detected.
The synchronous signal out of the LSU is detected by IC 300-W26pin. (NHSYNC)

After the LCD indicates "CALL SERVICE 2 ", turn the power OFF/ON, then confirm the waveform when the unit starts initial operation.

* You can check the LSU function by service mode *639.

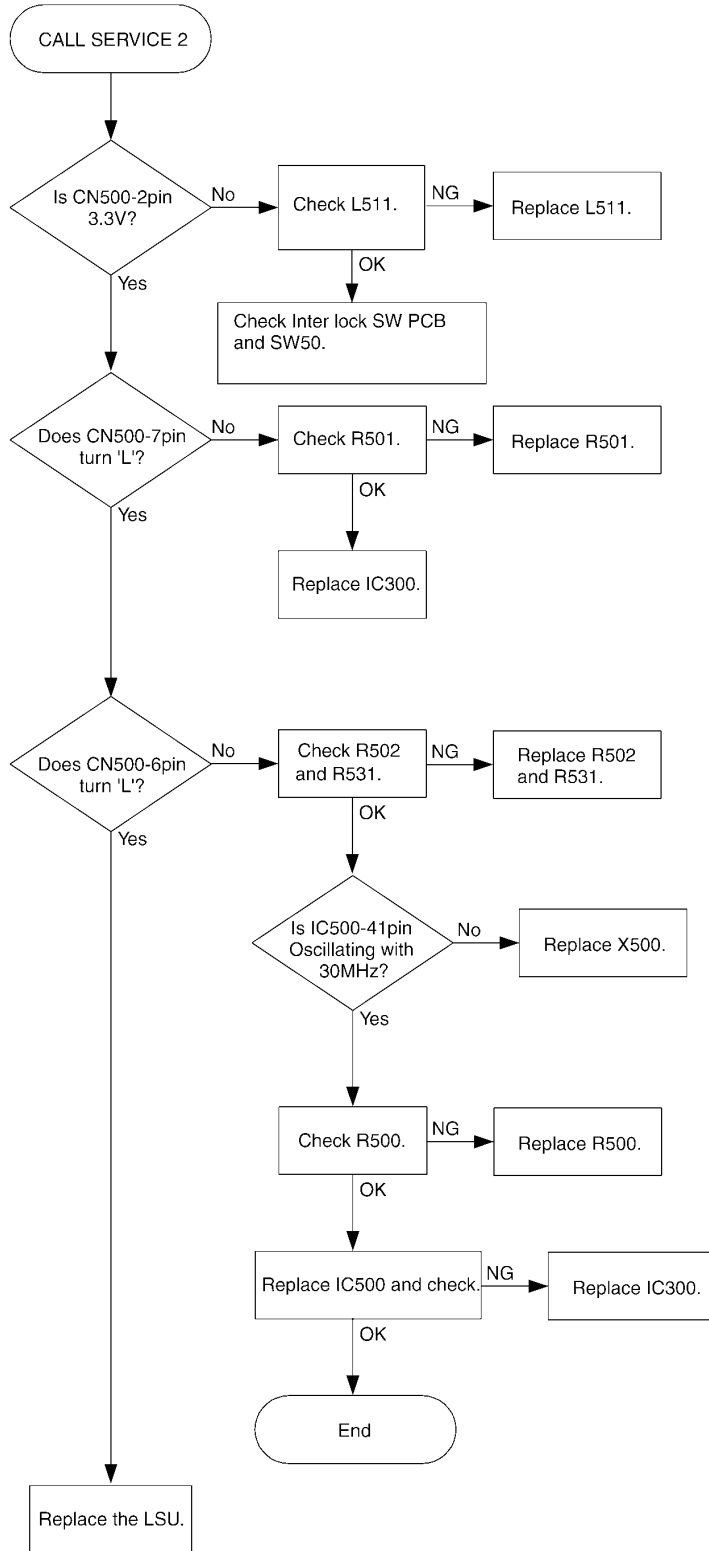

Note:
As for the "Pulse" waveform of the above flow chart, see the timing chart in LSU (Laser Scanning Unit) Section (P.75).

12.3.5.3. CALL SERVICE 3

"CALL SERVICE 3" means that the temperature of the fuser does not rise up to or exceed a constant temperature. The temperature is monitored with the thermistor inside the fuser and detected with the voltage input into IC300-C21.

After the LCD indicate "CALL SERVICE 3" , perform the MENU → # → 9000 → ✕ 529. Then, turn the power OFF/ON. Perform the SENSOR TEST in service mode. SENSOR TEST can be performed by pressing MENU → # → 9000 → ✕ 815. In this state, perform the copy operation to confirm how the two-digit numbers on the LCD change. In normal times, F6h(25°C)' is displayed in the waiting state, and 59h(195°C)' or its approximate numbers are displayed during printing.

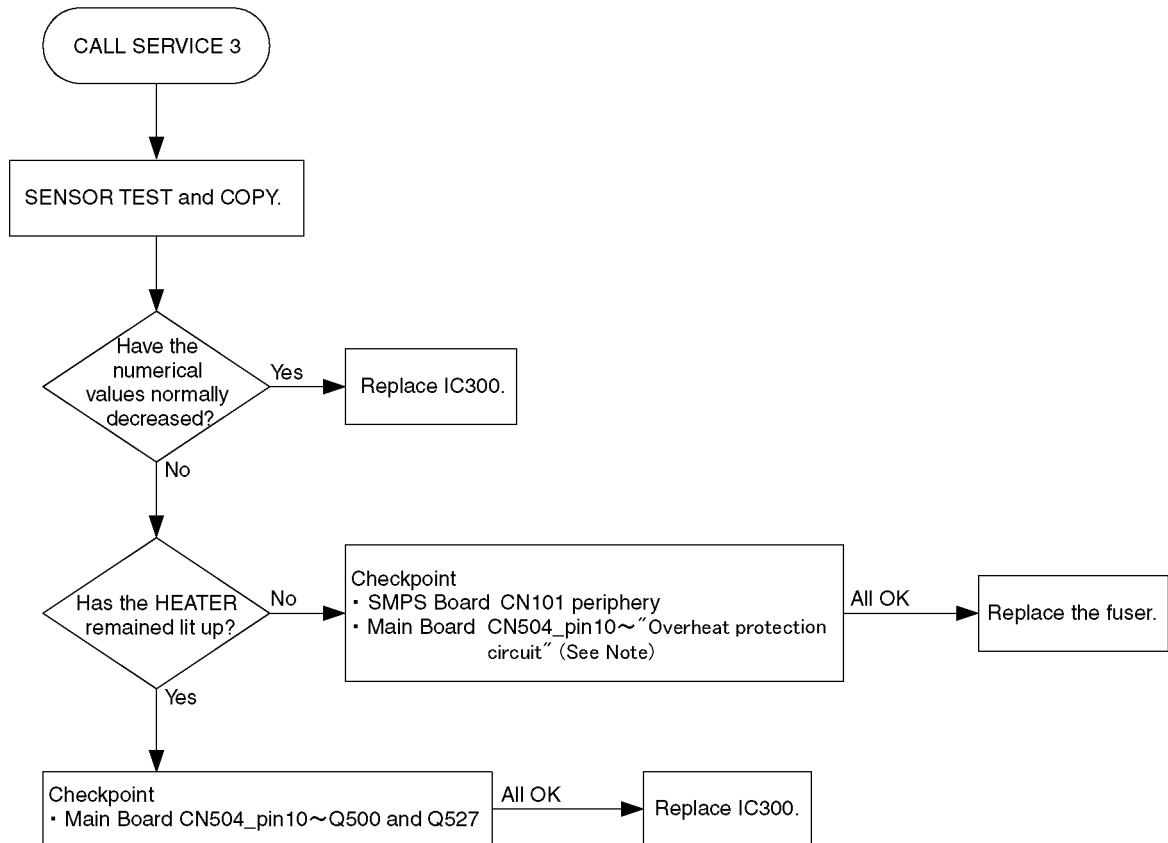

* When Call Service 3 occurred, the cause can be distinguished by service mode ✕655.

•*Service mode ✕655 tells the detection number and 3 latest temperatures of the thermistor. The detection point of the Call Service 3 and the thermistor temperature is displayed. Maximum 3 latest temperatures are displayed showing the newest on the left. [AABB CCDD EEFF] AA, CC and EE show the detection points and BB, DD and FF show their temperature detection points.

00: CALL SERVICE 3 did not occur.

01: means that the value of AD did not increased by 4 steps or more within 10sec soon after the heater was turned ON. (thermistor's open detection)

02: means that it did not reach the first stabilizing temperature (170°C: 73h) within 50 seconds.

03: means that it did not reach the second stabilizing temperature (195°C: 59h)* within 75 seconds after reaching the first stabilizing temperature (170°C: 73h).

04: means that it dropped to -60 deg or below by the temperature control after reaching the second stabilizing temperature (195°C: 59h)*.

05: means that it did not reach the first stabilizing temperature (170°C: 73h) within 35 seconds from detection temperature 1 (70°C: E2h).

06: means that it became 235°C: 39h or over during printing.

07: means that during printing the short of the thermistor (AD: 00h) was detected.

08: means that the thermistor's short (AD: 00h) were detected.

09: means that it became 235°C: 39h or over during sleep condition (heater OFF).

*: depend on its printing conditions (room temperature, number of printing, printing paper size etc.).

Note:

Refer to **Heat Lamp Control Circuit (P.97)** for technical description.

12.3.5.4. CALL SERVICE 4

"CALL SERVICE 4" means that the FAN does not run or the running of the FAN cannot be detected normally. The running of the FAN is detected by IC300-AE23 and AB26pin. "CALL SERVICE 4" is displayed when it detects NG. After repairing, copy. If "CALL SERVICE 4" is displayed, check again.

After the LCD indicates "CALL SERVICE 4", turn the power OFF/ON. Then, perform the FAN TEST in service mode. This can be performed by pressing MENU→#→9000→*677.

- 1: Normal operation (Default)
- 2: FAN1 & FAN2 (Optional): ON (High Speed)
- 3: FAN1 & FAN2 (Optional): ON (Low Speed)
- 4: Both FAN: OFF

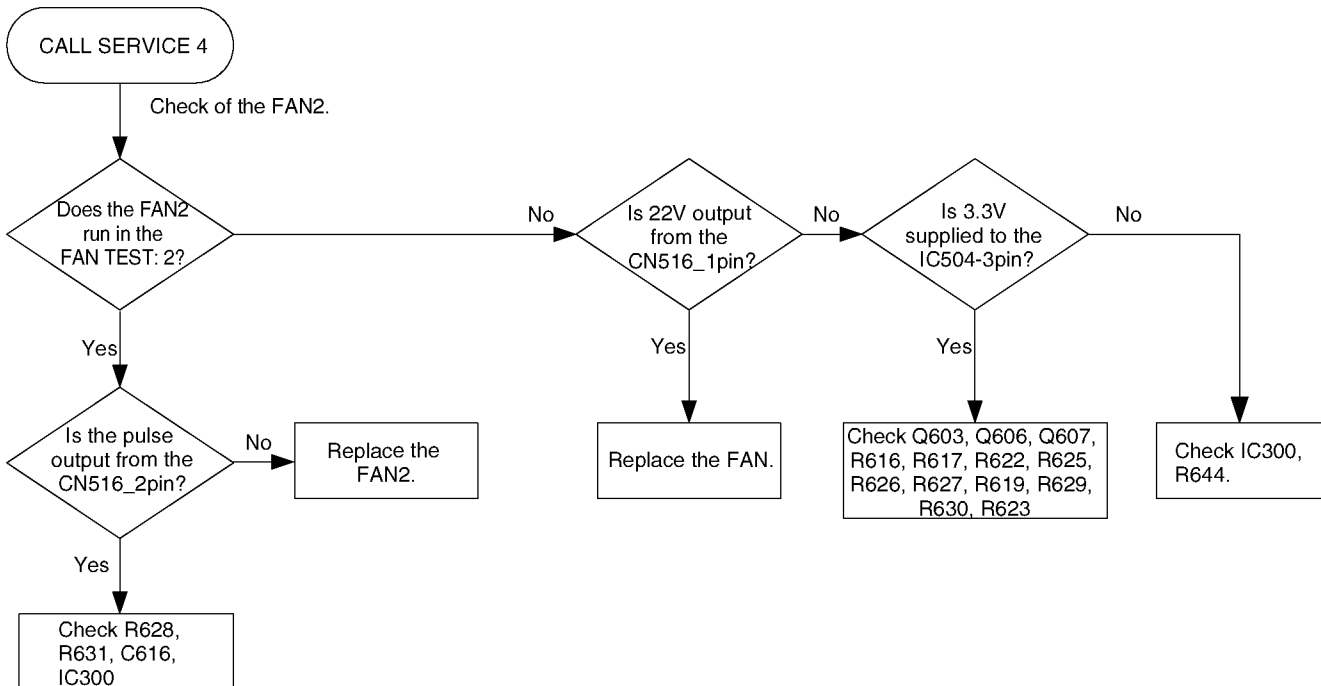
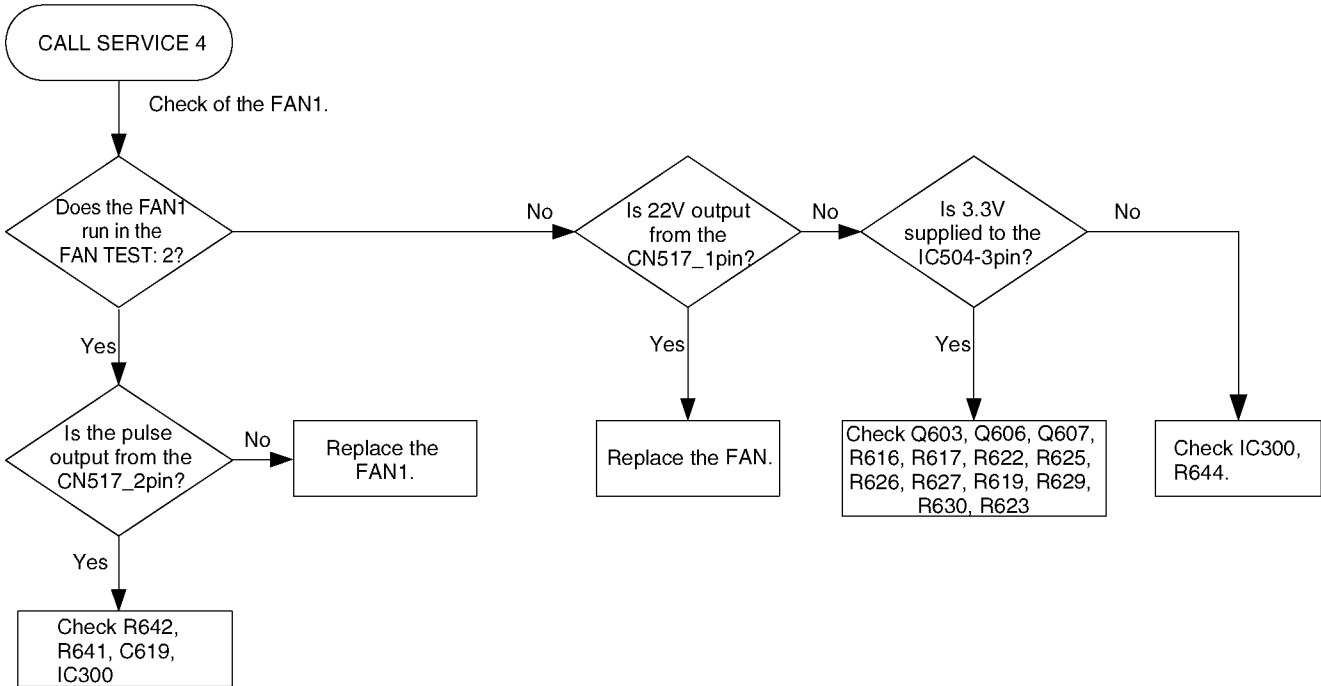

12.3.5.5. CALL SERVICE 5

“CALL SERVICE 5” means that Engine DC motor’s rotation detection signal (LD) does not become Low.

After the LCD indicates "CALL SERVICE 5", turn the power OFF/ON.
 Perform the MOTOR TEST in service mode.
 MOTOR TEST can be performed by pressing MENU → # → 9000 → *556.
 And Press 0 and SET buttons.

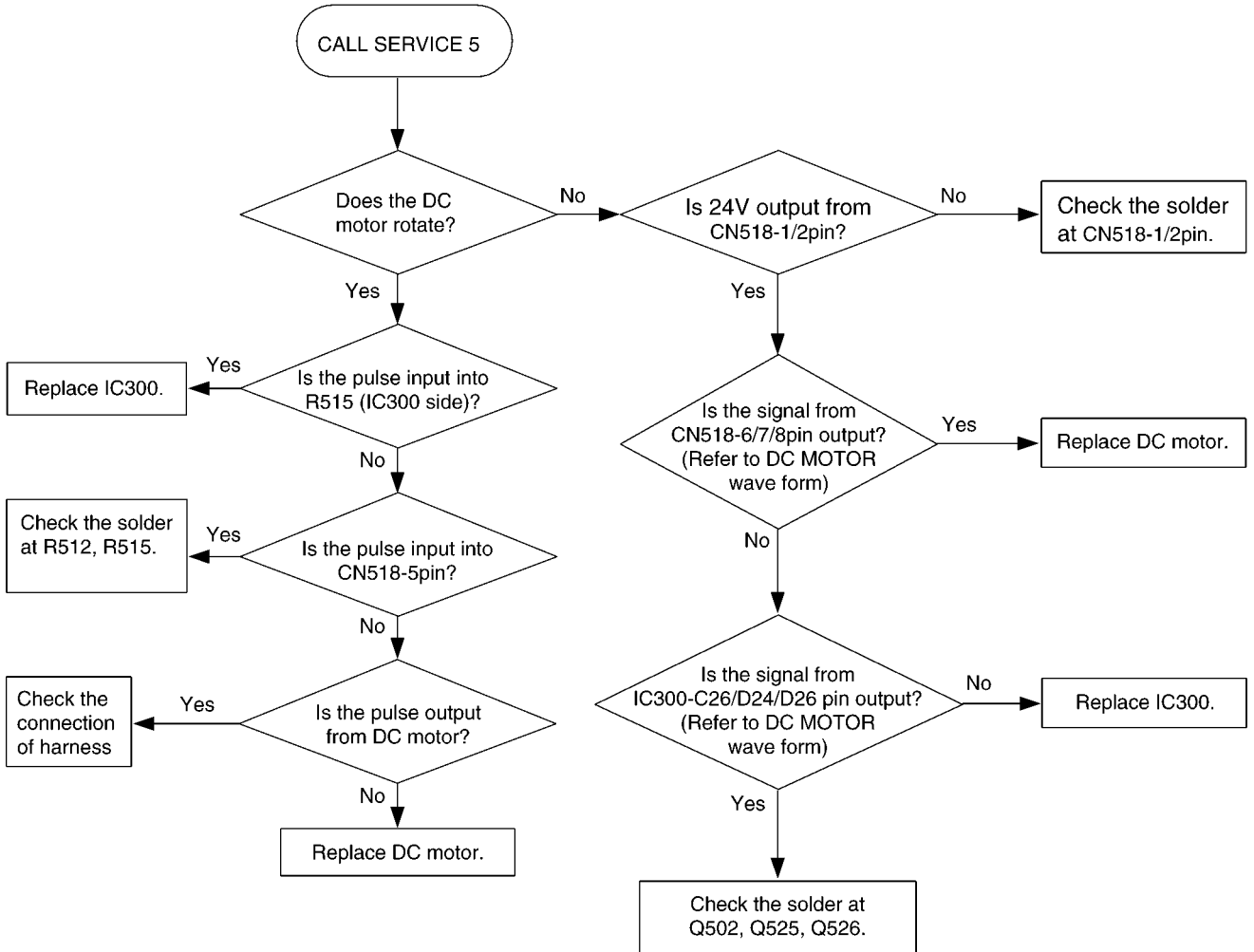

12.3.5.6. CALL SERVICE 6

“CALL SERVICE 6” indicates that abnormal charge voltage is output from the high voltage unit.

CALL SERVICE 6 appears when the charge voltage turns into abnormal voltage caused by charge wire breaking, short circuit, defect, and contact failure between Drum unit and main frame through charge and GRID terminals. When the charge voltage becomes abnormal, the high voltage unit shuts off the charge output, and then trouble detection signal (HVERR) is output from pin 2 of CN1. When the main PCB detects the trouble detection signal, the unit displays CALL SERVICE 6. CALL SERVICE 6 is canceled by turning the power OFF then ON. (When the problem is not solved, CALL SERVICE 6 will be displayed again.)

Confirming the contact points of the main frame

- Check the dirt on the high voltage terminals.
- Check if the spring pressure of each high voltage terminal is strong enough. (Isn't it distorted or bent?)
- When a Drum unit is installed on the main frame, are the terminals connected to the main frame surely?

Confirming the Drum unit (In case that replacement of the development unit caused CALL SERVICE 6 to appear again.)

- Check if the charge wire has breaking, loose, or dirt, etc.
- In case that the dirt is found on the charge wire, does the unit become normal after getting rid of the dirt?
The charge wire should be cleaned with a soft cloth soaked in ethanol. Be careful not to cut the wire.
- Are the contact terminals of Drum unit clean?

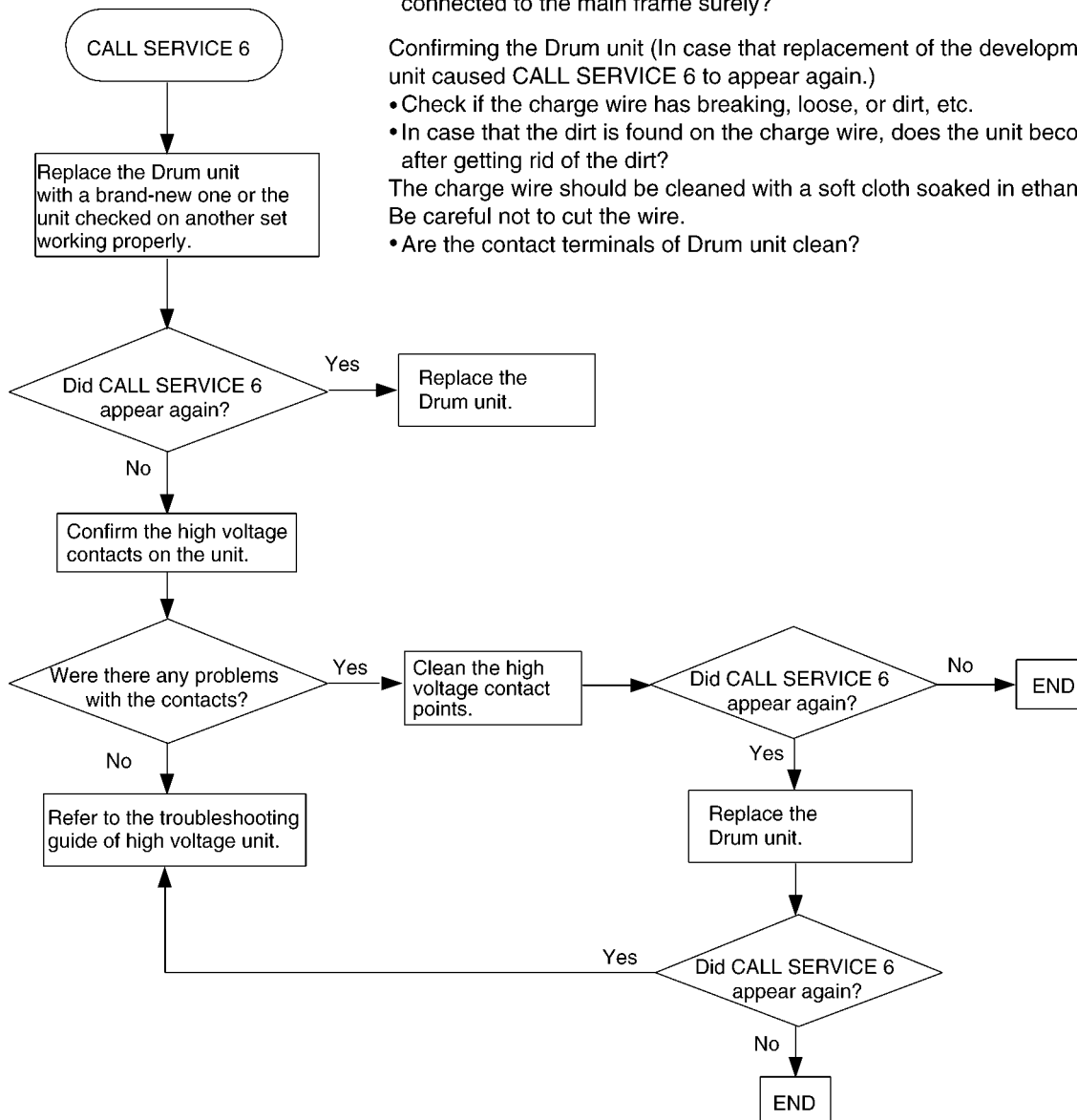

12.3.5.7. CALL SERVICE 17

“CALL SERVICE 17” means that the OPC First use sensor problem.

Especially "CALL SERVICE 17" is appeared when the fuse which is installed in the OPC Unit PCB is not blown out within a specific time.

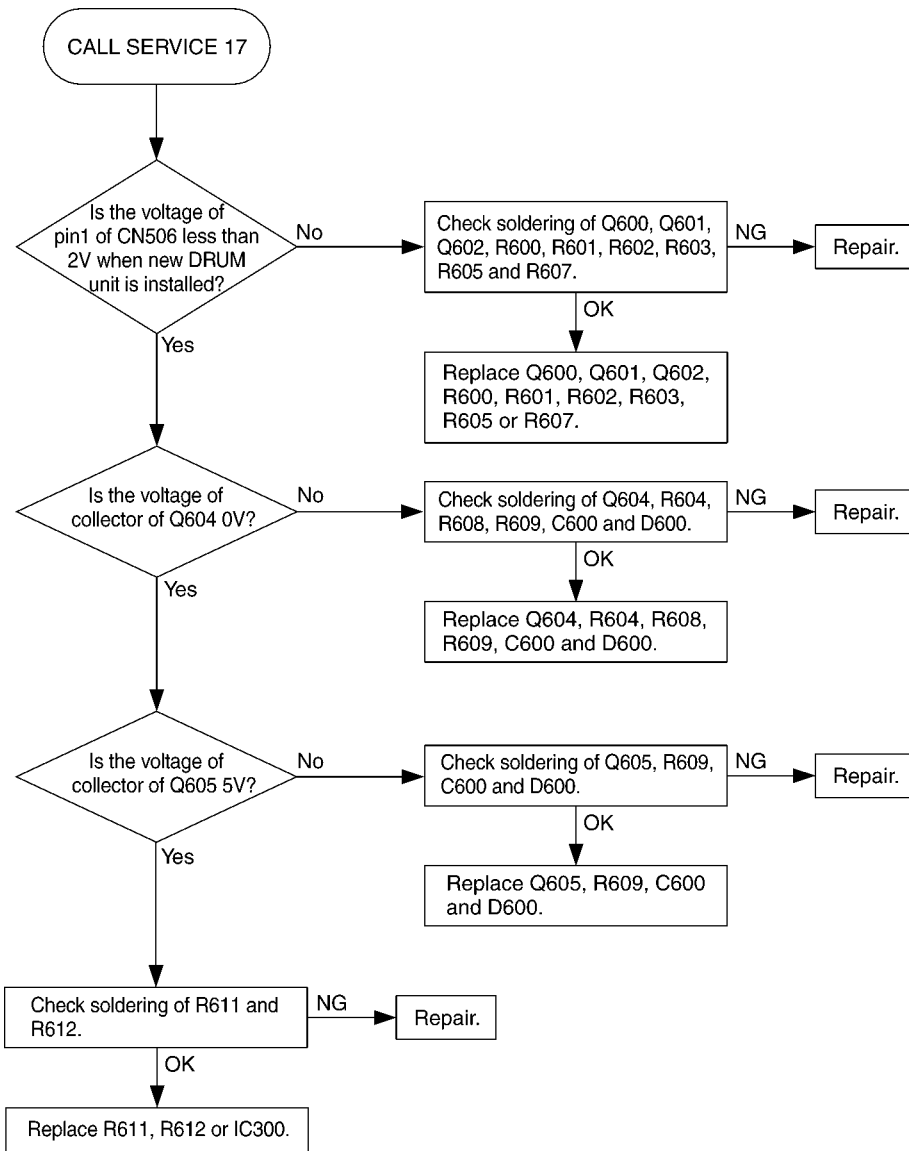

Note:
Refer to OPC Life Sensor Circuit (P.87) for technical description.

12.3.5.8. CALL SERVICE 22

"CALL SERVICE 22" means that the Toner First use sensor problem.

Especially "CALL SERVICE 22" is appeared when the fuse which is installed in the Toner Unit PCB is not blown out within a specific time.

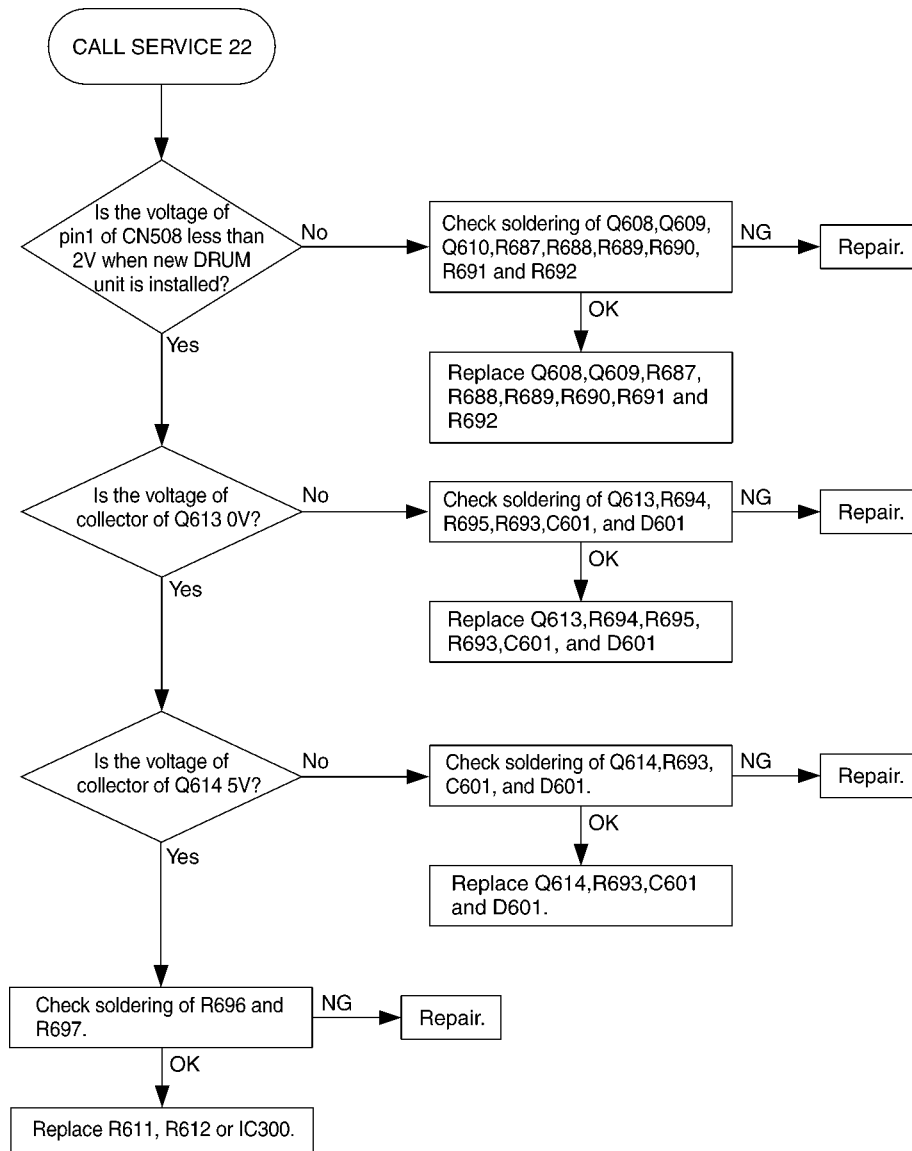

Note:
Refer to Toner Sensor (P.86) for technical description.

12.3.6. Print

12.3.6.1. Ghost Image

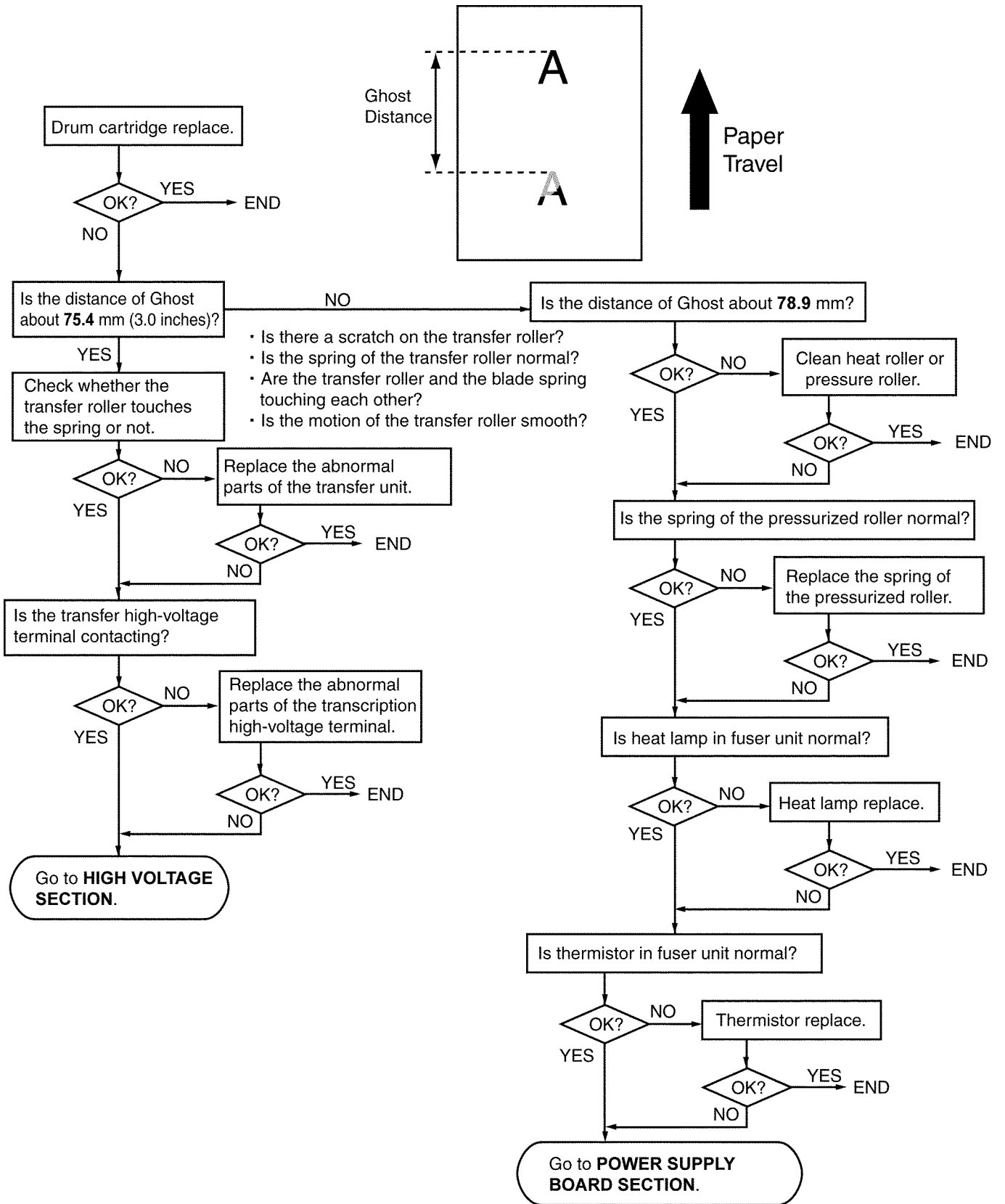

CROSS REFERENCE:
 High Voltage Section (P.251)
 Power Supply Board Section (P.106)

12.3.6.2. Dark or White Vertical Line

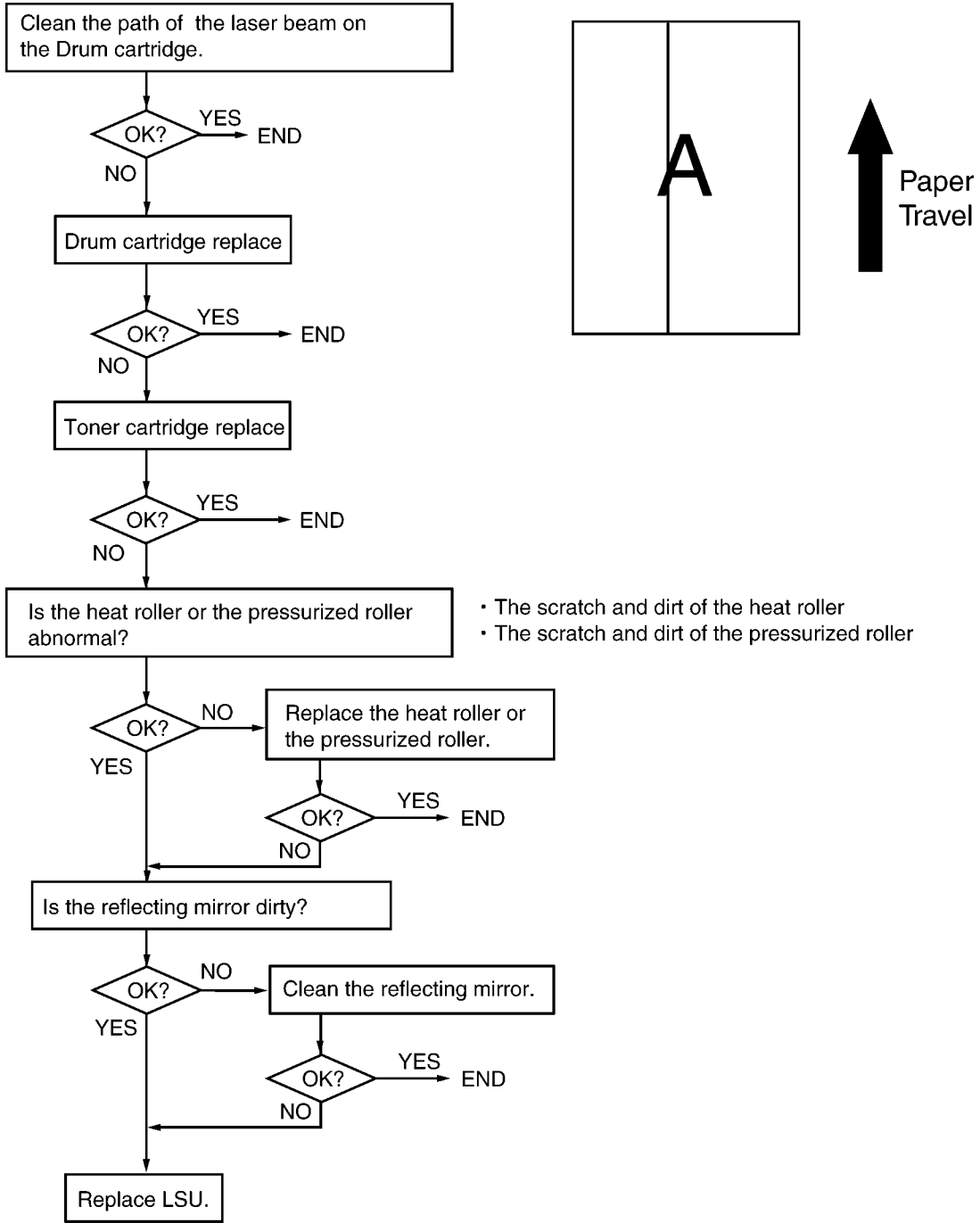

Note:
 When wiping, reflecting mirror, use a dry and soft cloth.

12.3.6.3. Dark or White Horizontal Line

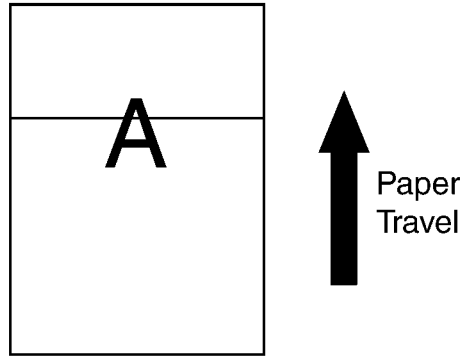
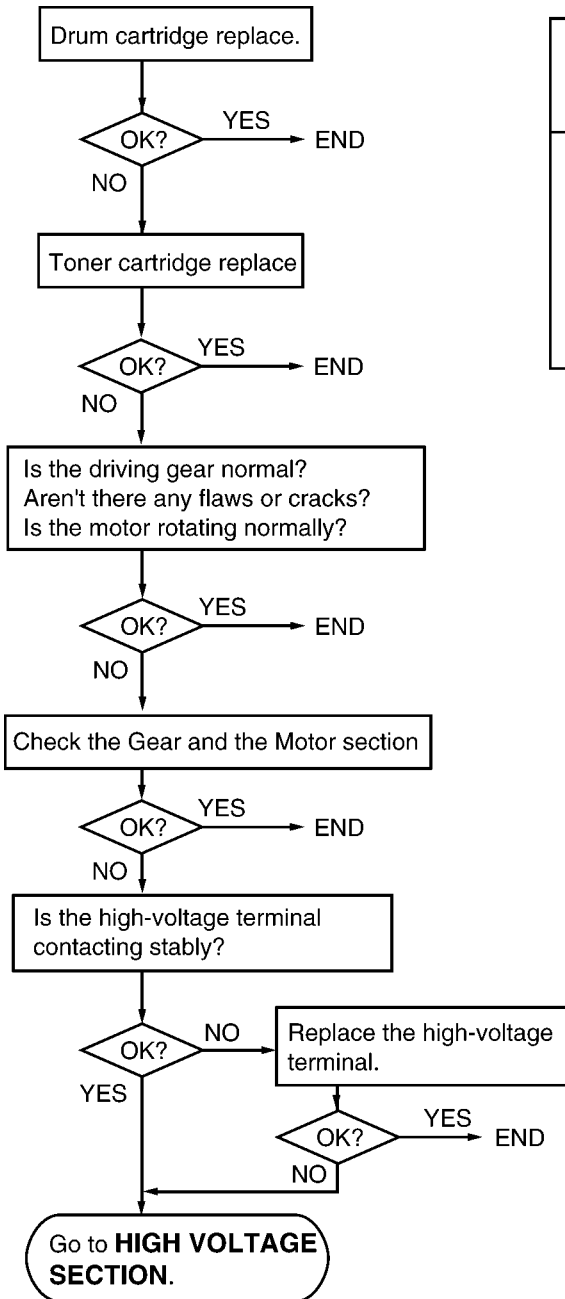

- It is necessary to describe the information about the lines that cannot be troubleshot in such as halftone.
- When there is the information about the troubleshot horizontal line, please add the description of it.

CROSS REFERENCE:
High Voltage Section (P.251)

12.3.6.4. Dirty or Half Darkness Background

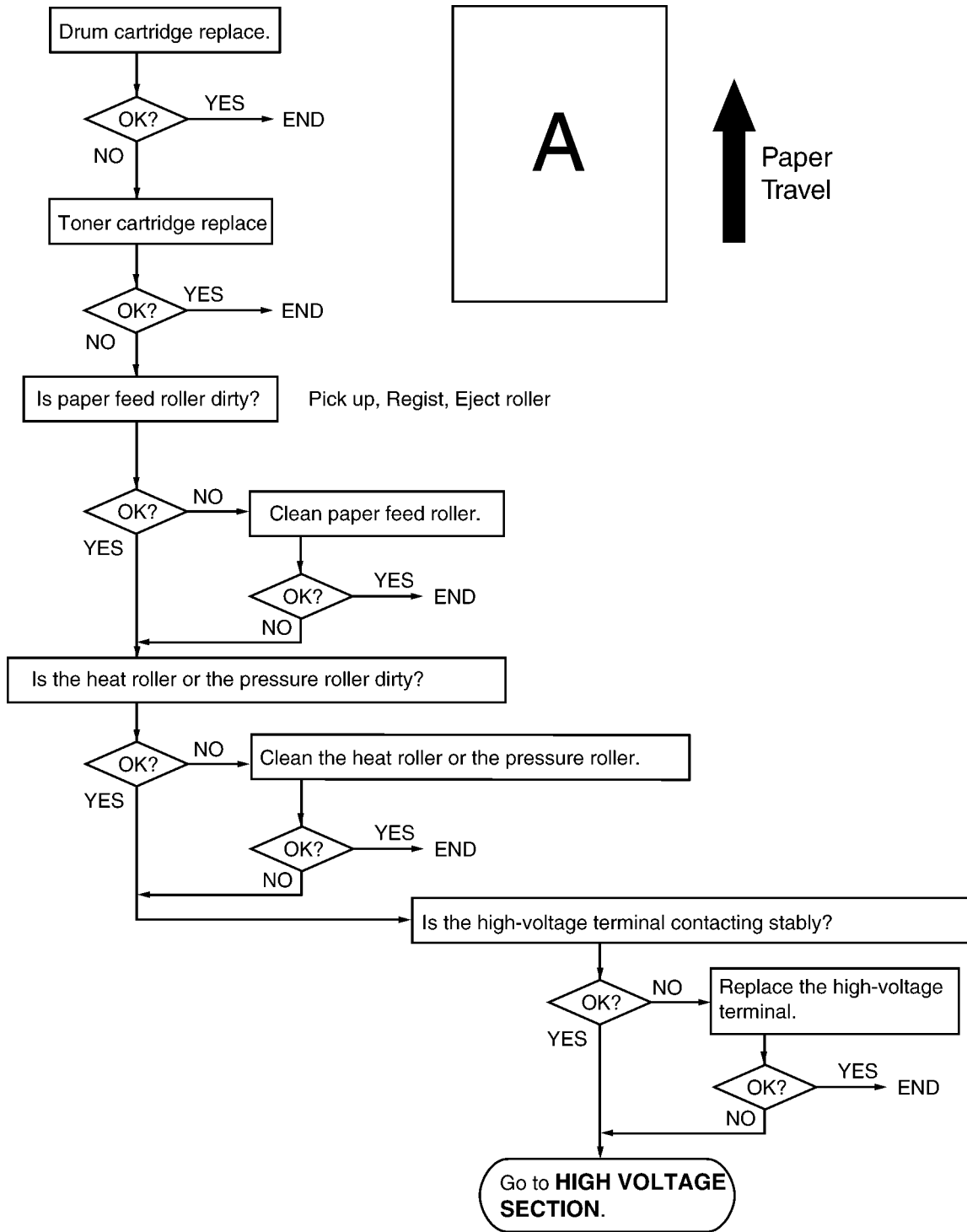

CROSS REFERENCE:
High Voltage Section (P.251)

12.3.6.5. Black Print

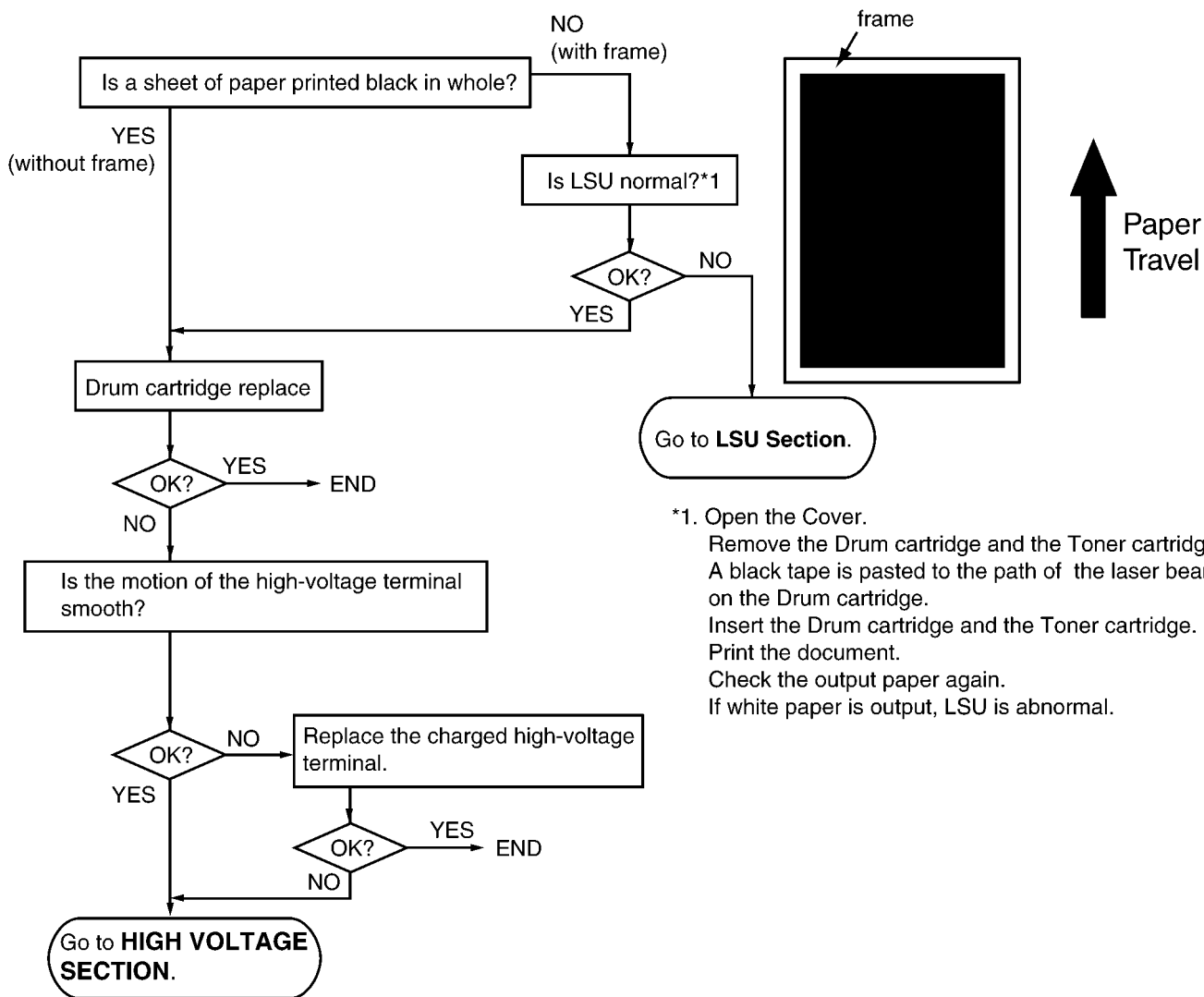

*1. Open the Cover.
 Remove the Drum cartridge and the Toner cartridge.
 A black tape is pasted to the path of the laser beam on the Drum cartridge.
 Insert the Drum cartridge and the Toner cartridge.
 Print the document.
 Check the output paper again.
 If white paper is output, LSU is abnormal.

CROSS REFERENCE:

High Voltage Section (P.251)

LSU (Laser Scanning Unit) Section (P.75)

12.3.6.6. Light Print

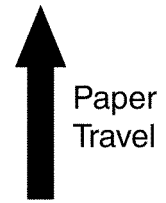
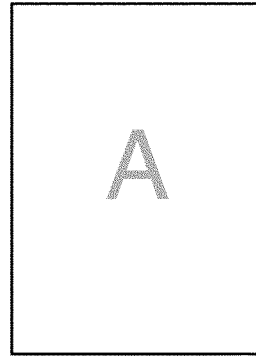
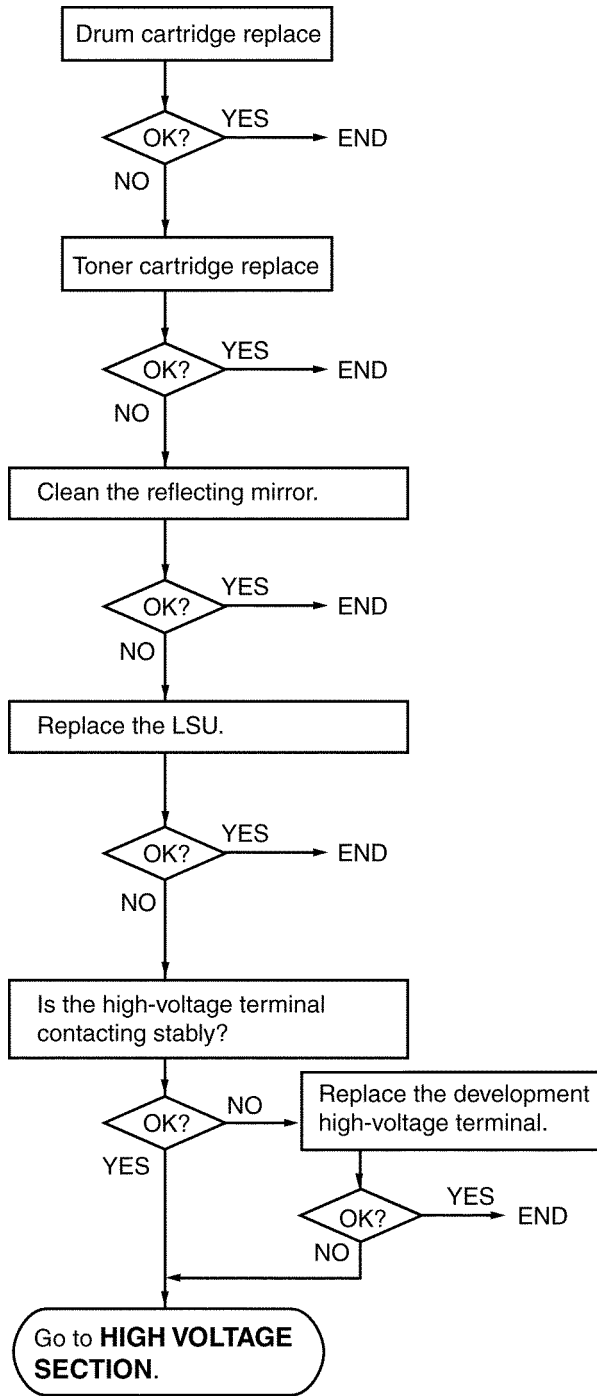

CROSS REFERENCE:
High Voltage Section (P.251)

12.3.6.7. Black or White Point

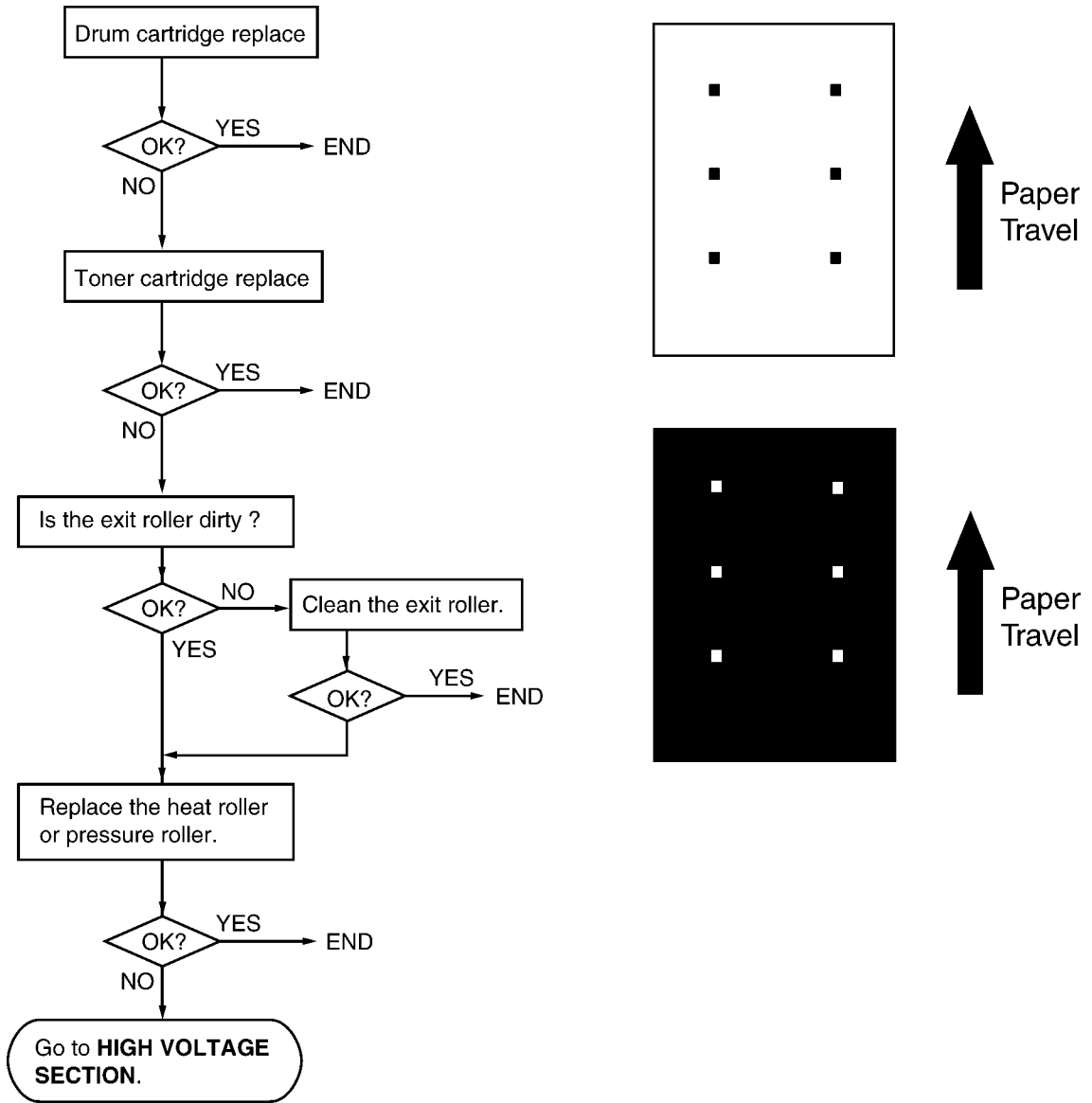

12.3.7. Recording Paper Feed

12.3.7.1. Multiple Feed

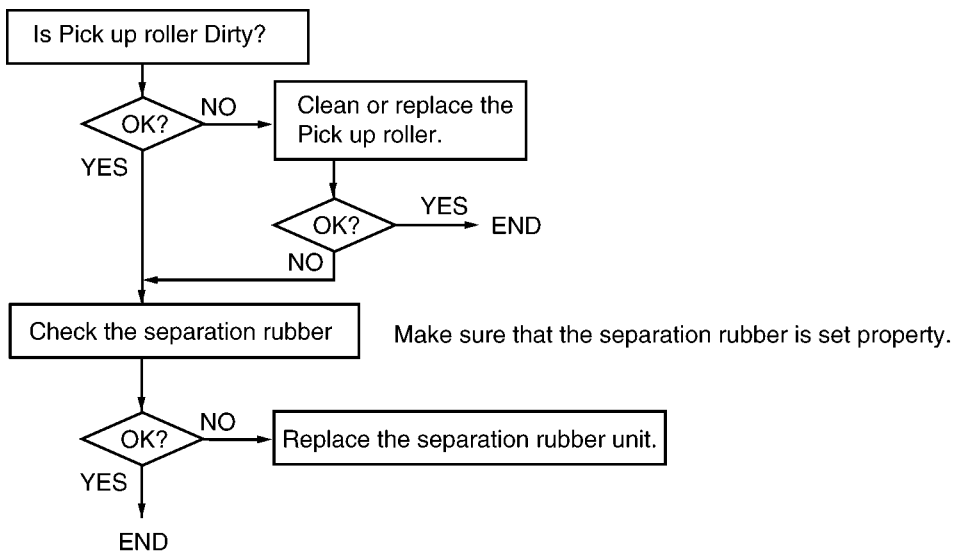

12.3.7.2. The Recording Paper Is Waved or Wrinkled

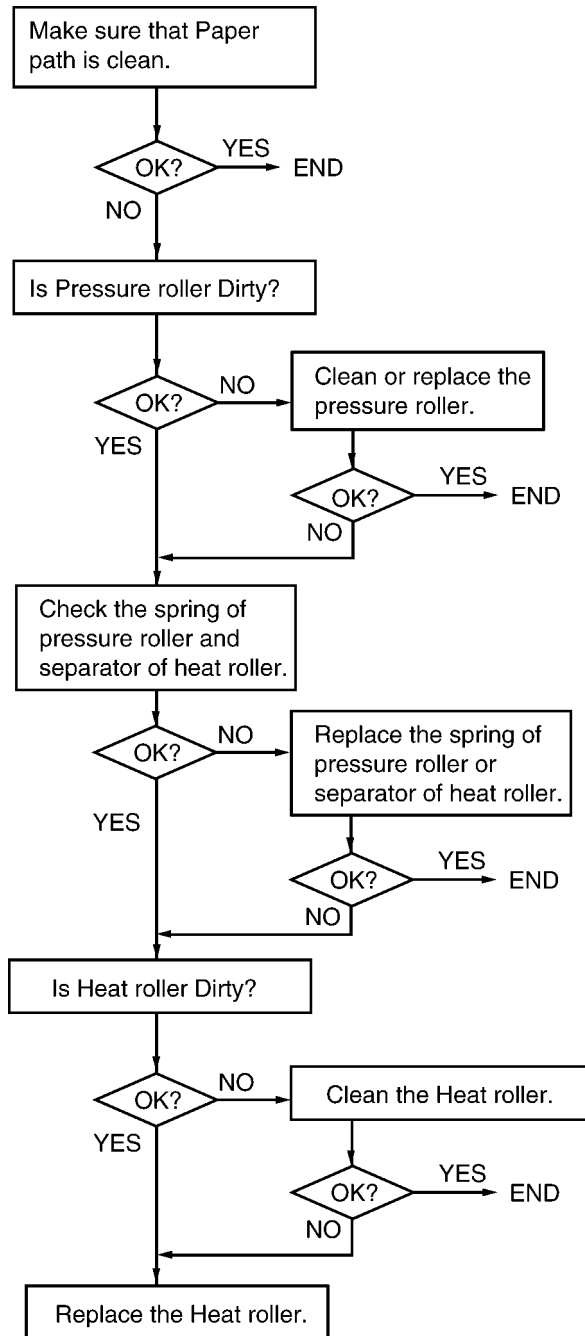

12.3.7.3. Skew

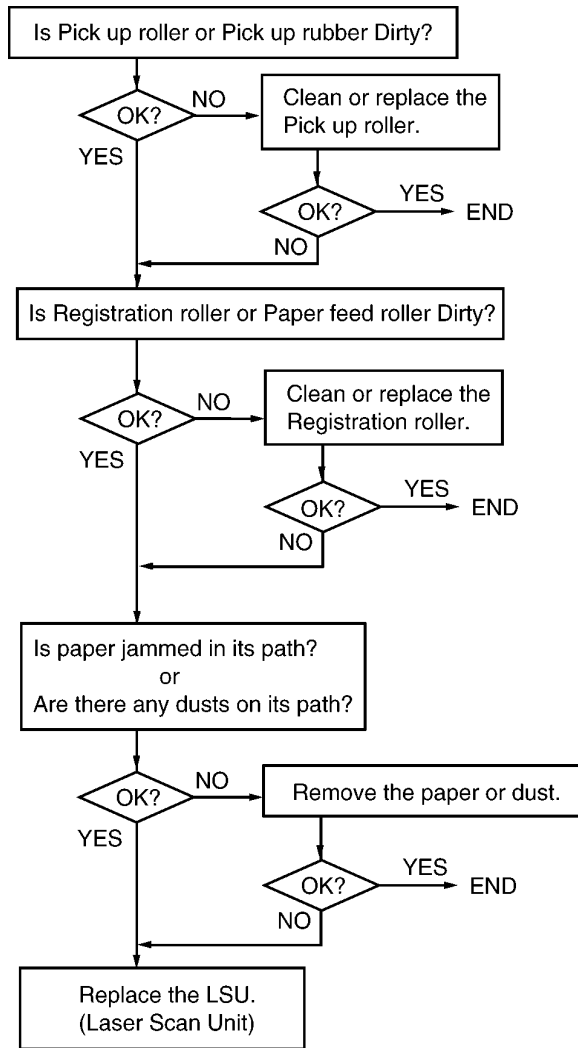

12.3.7.4. The Recording Paper Does Not Feed

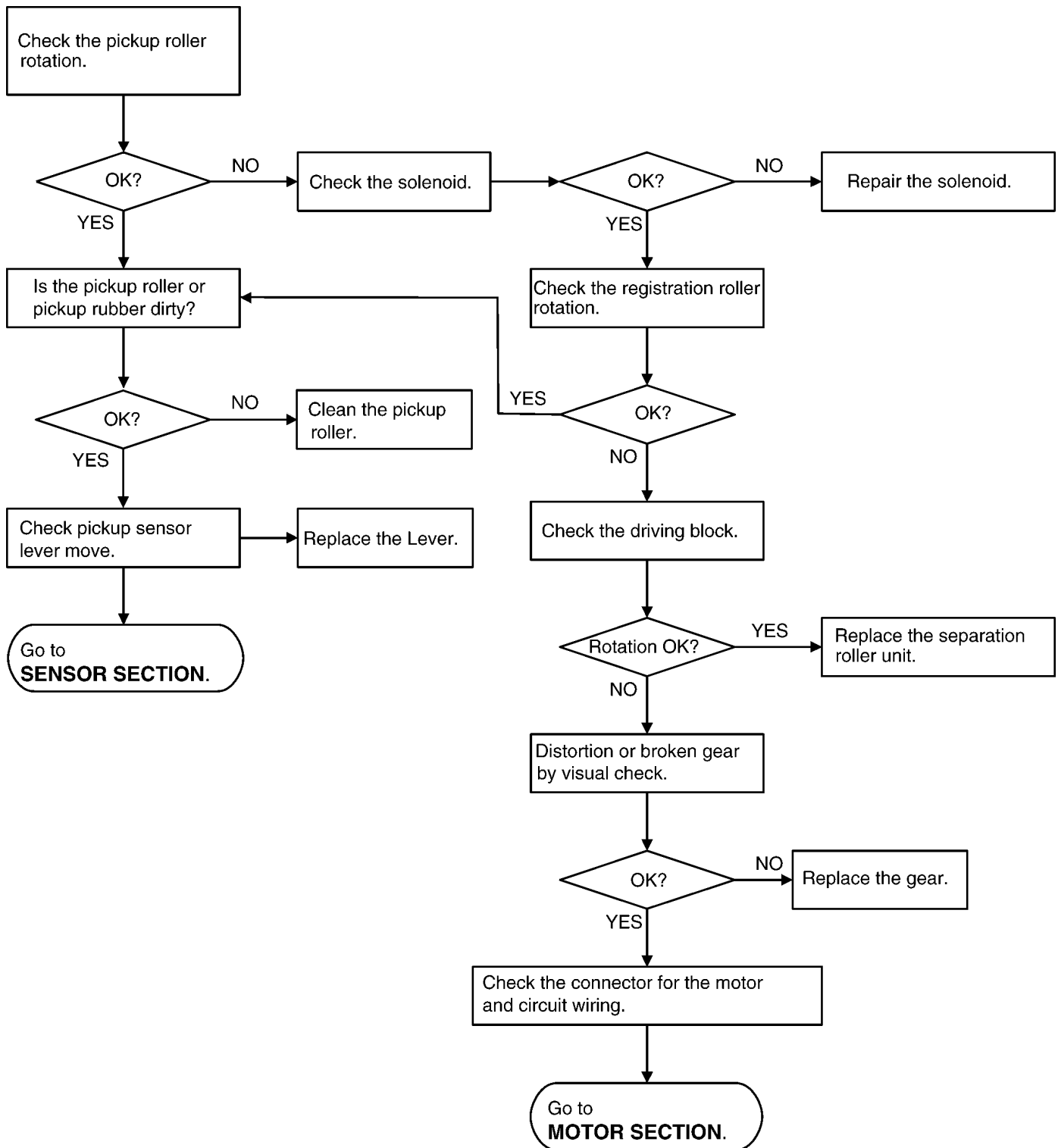

CROSS REFERENCE:
Sensor Section (P.237)
Motor Section (P.244)

12.3.7.5. The Recording Paper Jam

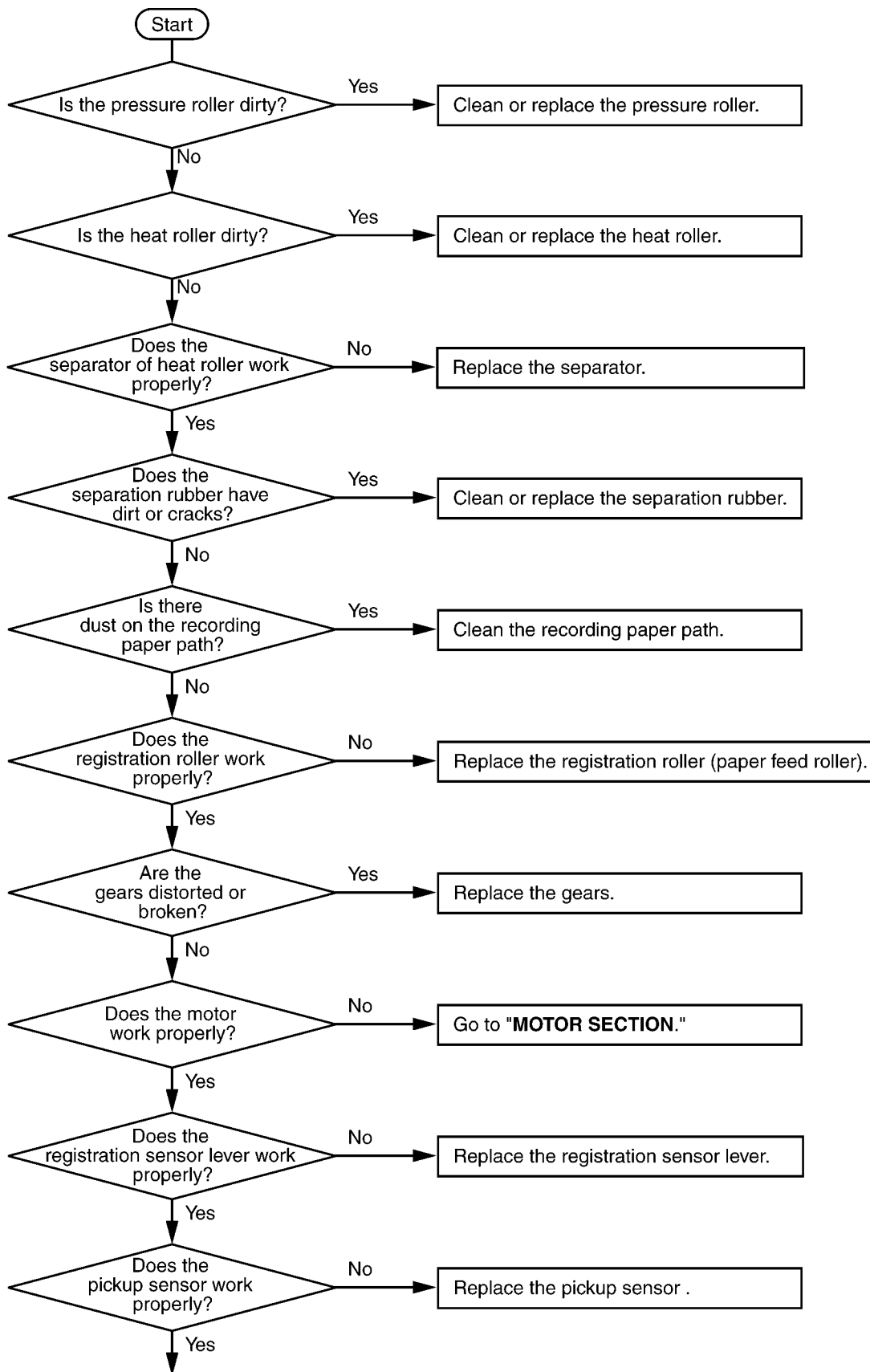

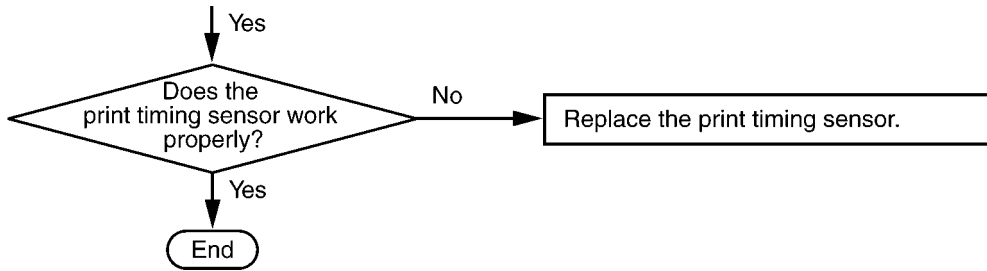

CROSS REFERENCE:

FAN Motor Section (P.65)

When the recording paper jam is occurred, the service mode *630 distinguishes the cause.

- 0:No Jam
- 1:Exit Sensor turns ON, though not under the conditions for ON.
- 2:Exit Sensor turns OFF, though not under the conditions for OFF.
- 3:After Exit Sensor falls, it turns ON already on terminating of Cancel Timer.
- 4:After Exit Sensor rises, it turns ON already on terminating of Cancel Timer.
- 5:Top Sensor turns ON, though not under the conditions for ON.
- 6:Top Sensor turns OFF, though not under the conditions for OFF.
- 7:After Top Sensor falls, it turns ON already on terminating of Cancel Timer.
- 8:After Top Sensor rises, it turns OFF already on terminating of Cancel Timer.
- 9:Exit Sensor never turns ON in the specified time, though Top Sensor turns ON.
- 10:Top Sensor MAX-length-JAM.
- 11:Exit Sensor never turns OFF in the specified time, though Top Sensor turns OFF.
- 12:Registration Sensor turns ON, though not under the conditions for ON.
- 13:Registration Sensor turns OFF, though not under the conditions for OFF.
- 14:After Registration Sensor falls, it turns ON already on terminating of Cancel Timer.
- 15:After Registration Sensor rises, it turns OFF already on terminating of Cancel Timer.
- 16:Top Sensor never turns ON in the specified time, though Registration Sensor turns ON.
- 17:Registration Sensor MAX-length-JAM.
- 18:Top Sensor never turns OFF in the specified time, though Registration Sensor turns OFF.
- 99:Before Motor Rotation, one of sensors turn ON.

12.3.7.6. Back Side of The Recording Paper is Dirty

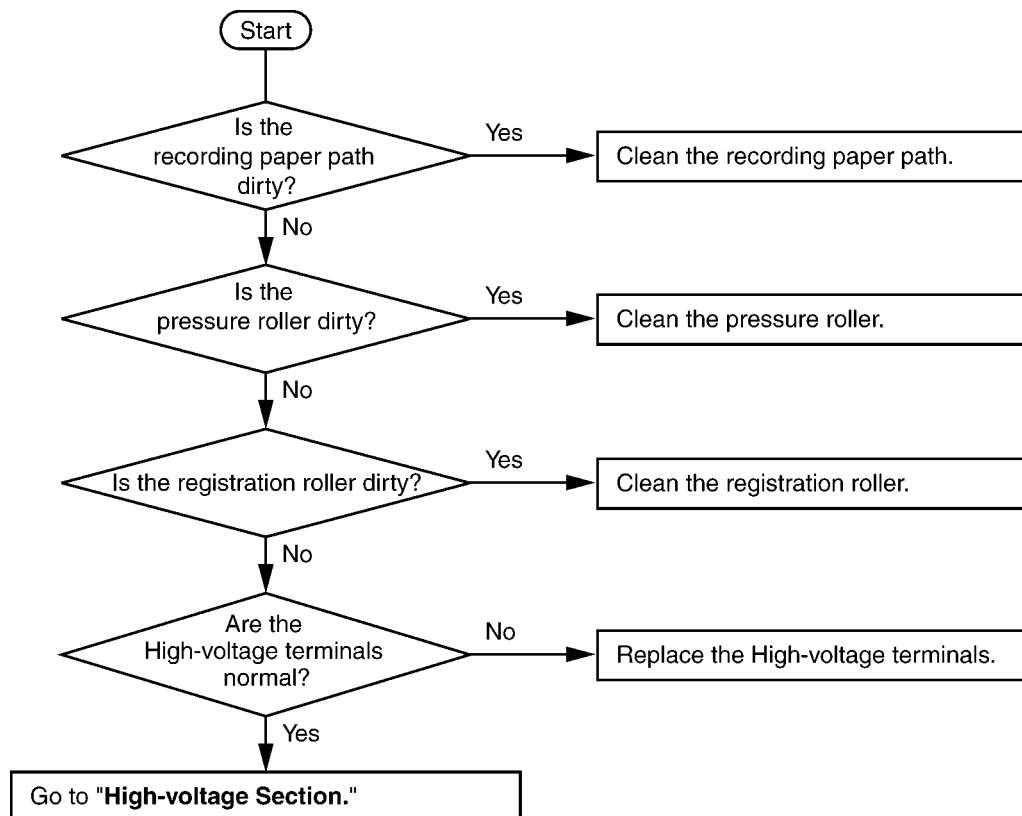

CROSS REFERENCE:

High Voltage Section (P.251)

12.3.8. ADF (Auto document feed) Section

12.3.8.1. No Document Feed, Document JAM and Multiple Document Feed

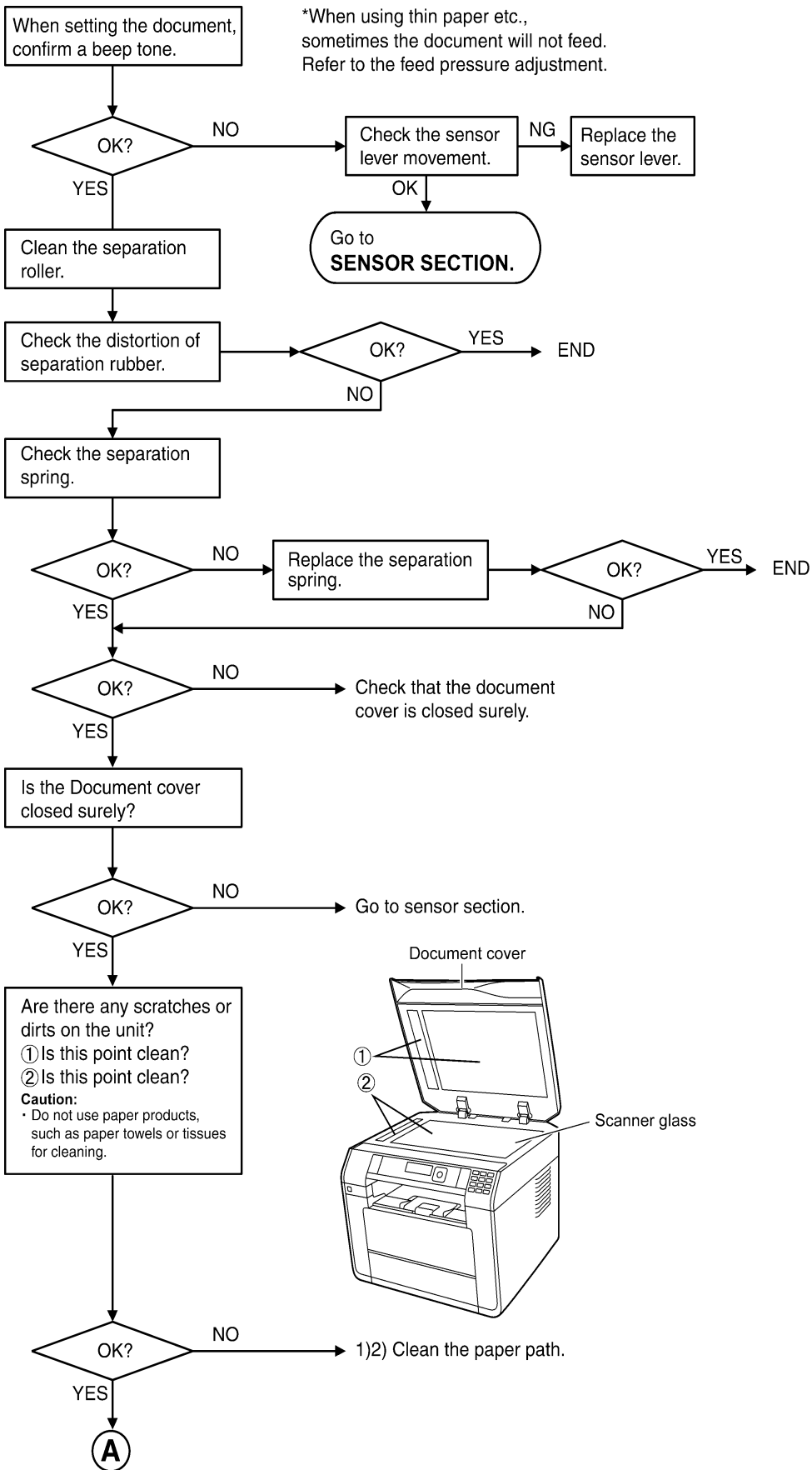

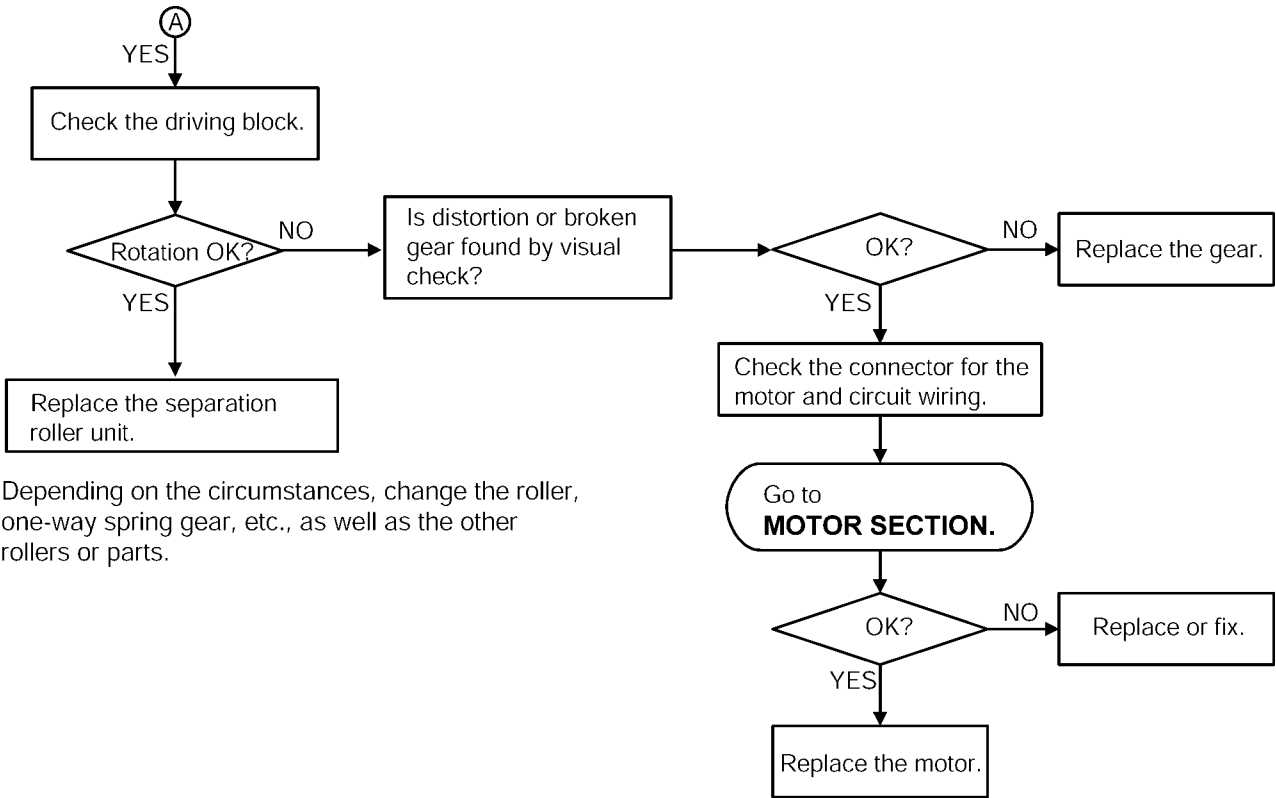

Depending on the circumstances, change the roller, one-way spring gear, etc., as well as the other rollers or parts.

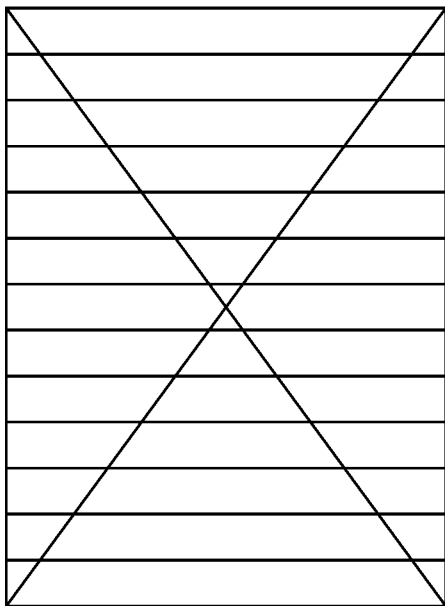
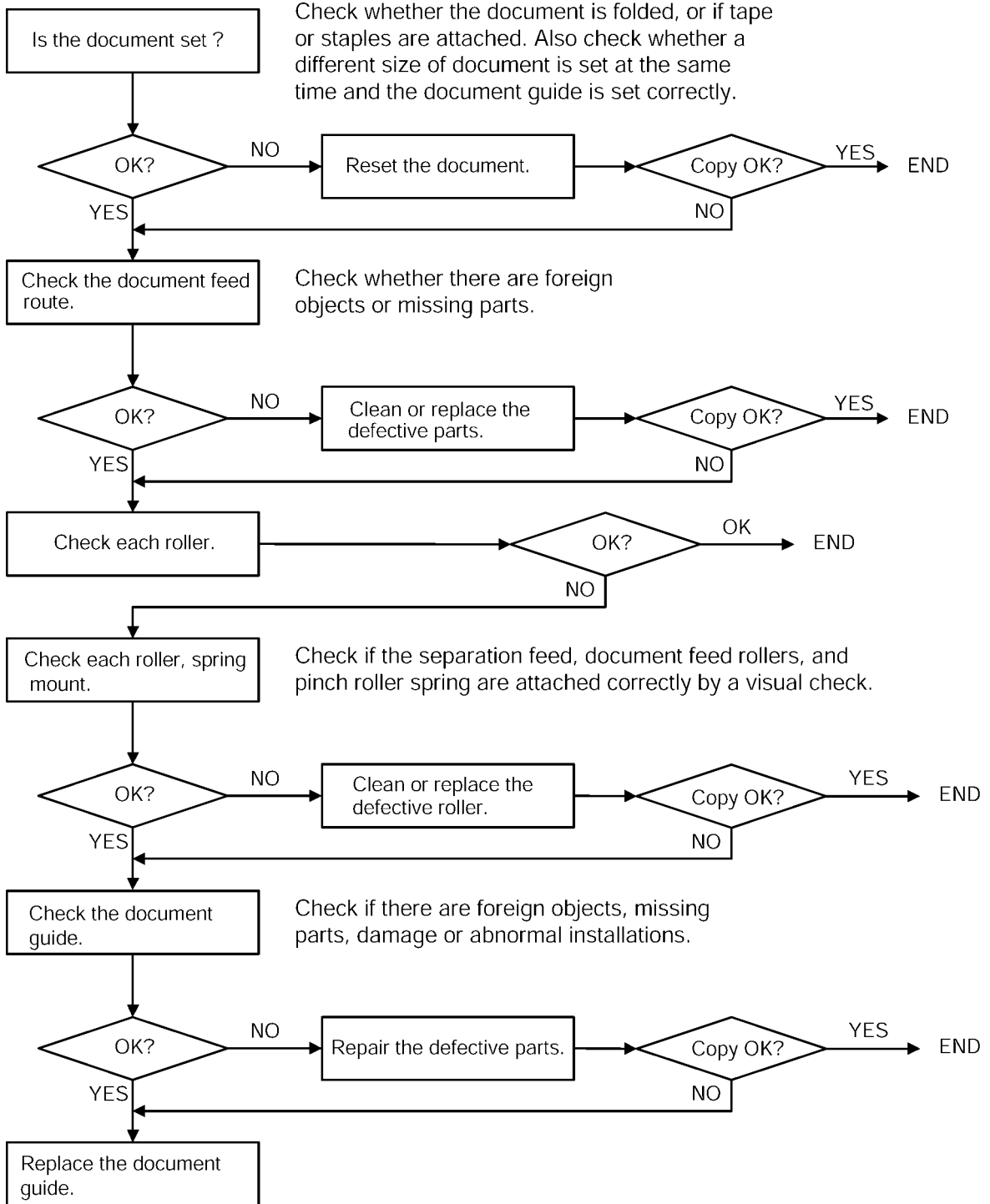

Fig. b

When confirming if the characters are extended or distorted on, if the feed problem occurs, use this test chart. (Fig b)

CROSS REFERENCE:
Sensor Section (P.237)
Motor Section (P.244)

12.3.8.2. Skew (ADF)



12.3.8.3. Scanner Glass

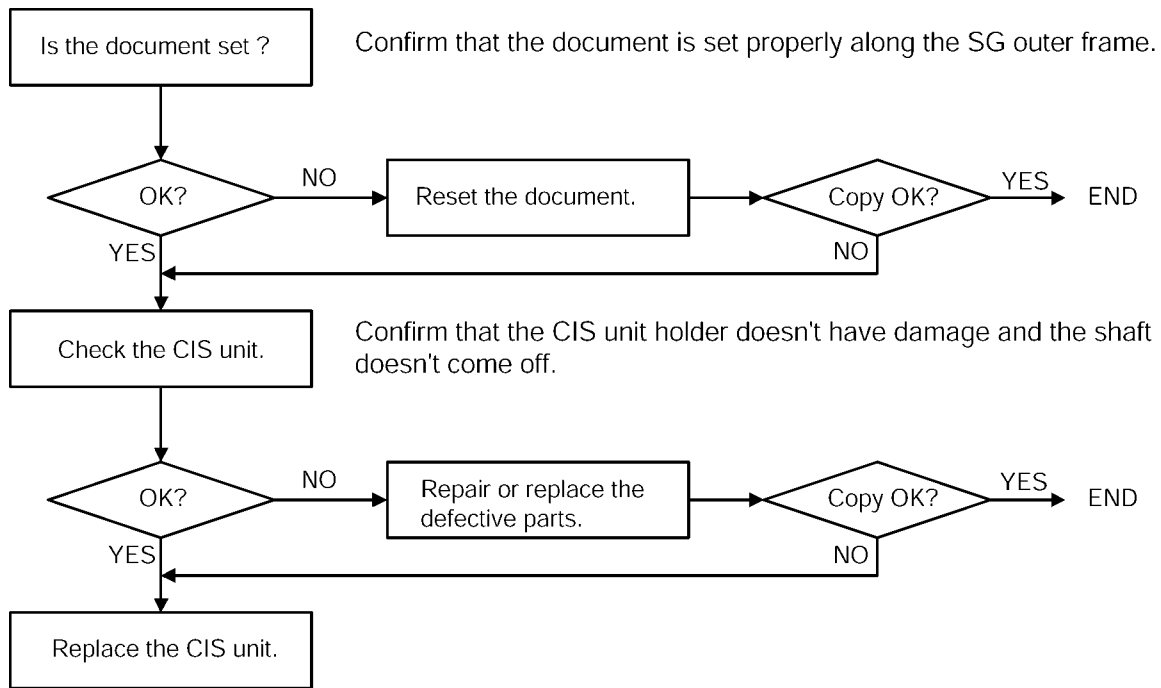

12.3.8.4. The Sent FAX Data is Skewed

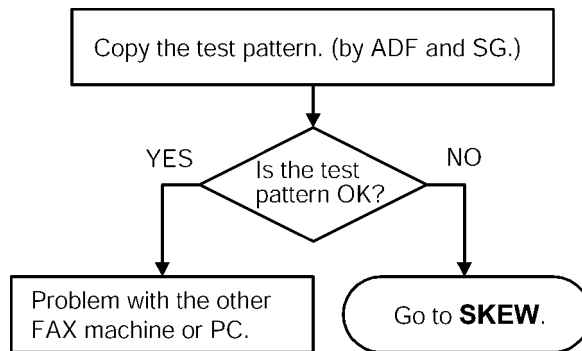

CROSS REFERENCE:
Skew (ADF) (P.211)

12.3.8.5. The Received FAX Data is Skewed

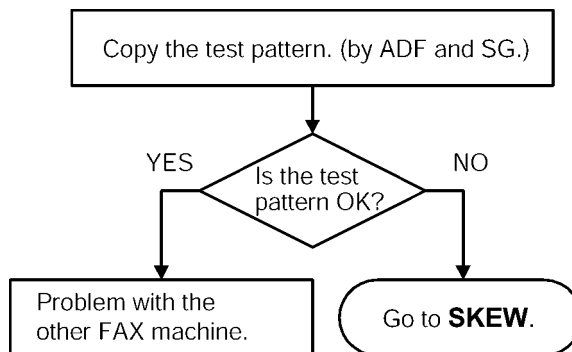

CROSS REFERENCE:
Skew (P.205)

12.3.8.6. The Received or Copied Data is Expanded

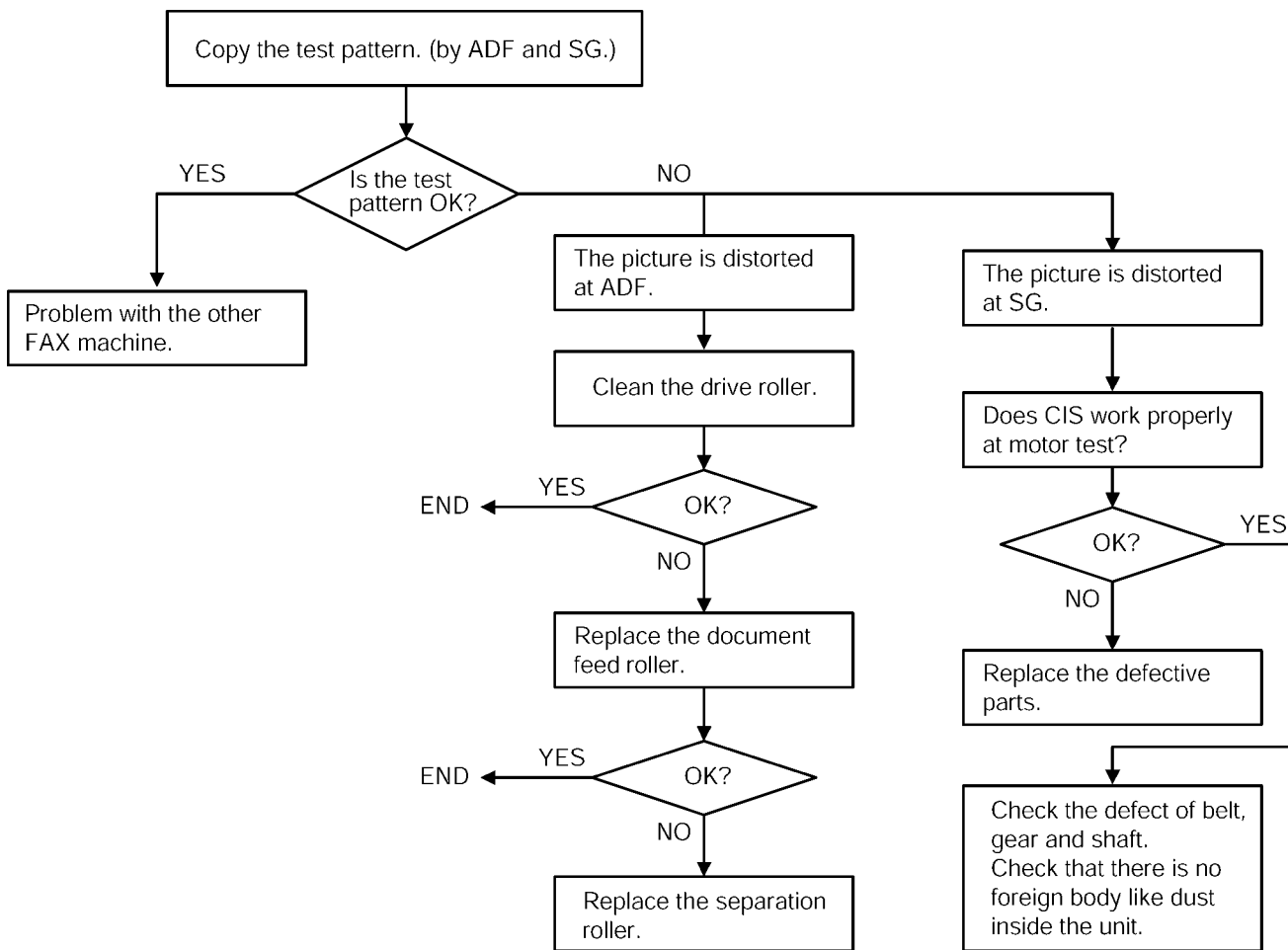

12.3.8.7. Black or White Vertical Line is Copied

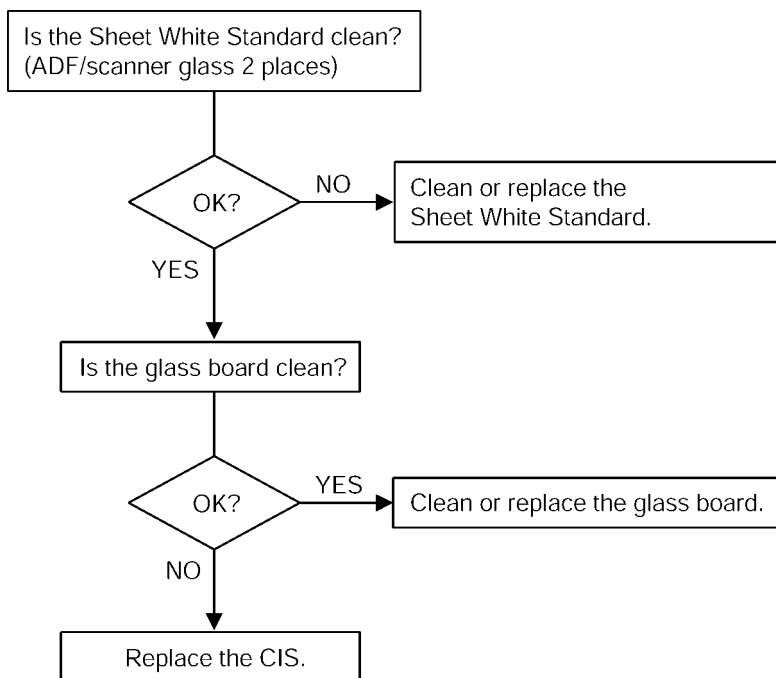

12.3.8.8. An Abnormal Image is Copied

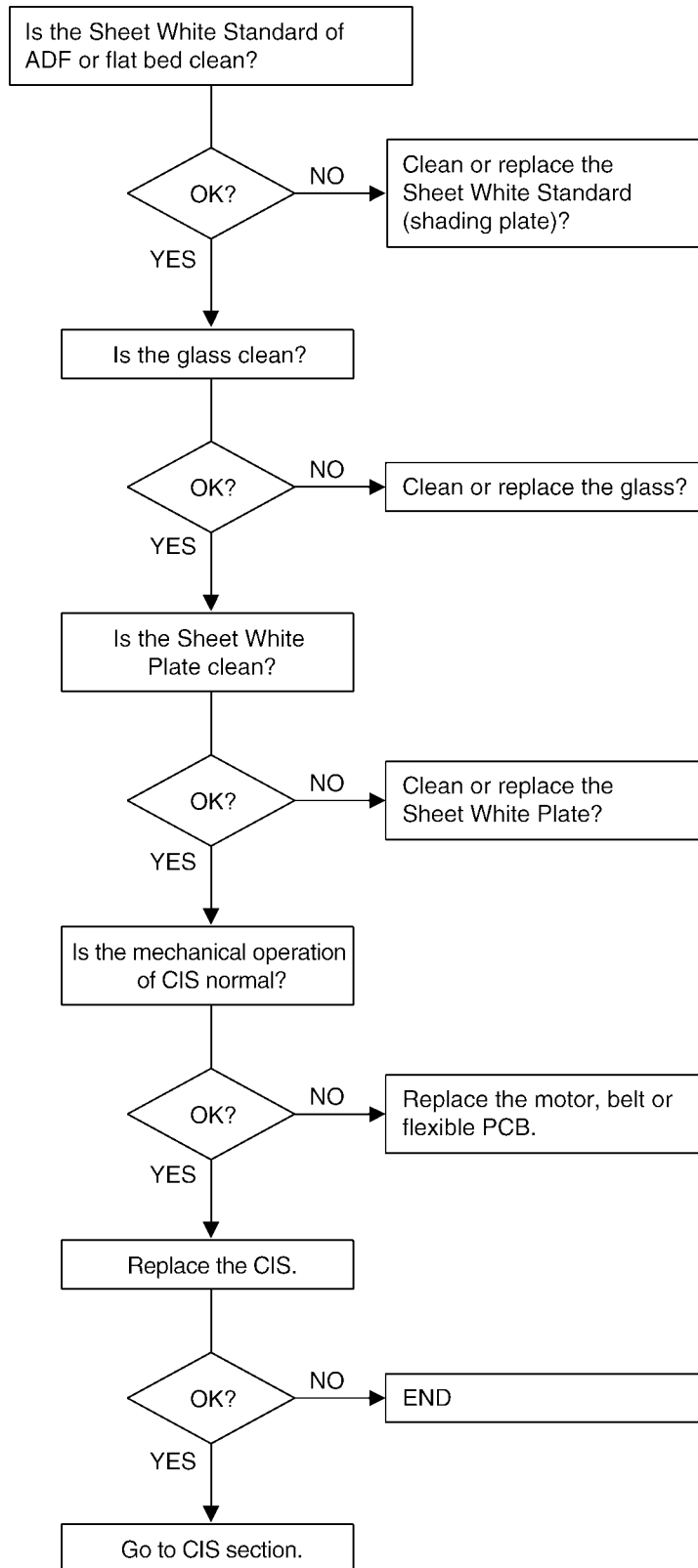

CROSS REFERENCE:
CIS Control Section (P.248)

12.3.9. Communication Section

Find the problem in the table shown below, and refer to the corresponding troubleshooting procedure in **Defective Facsimile Section** (P.216).

No.	Symptom	Content	Possible cause
1	The paper dose not feed properly when faxing. (Copying is also not possible.)	Troubleshooting	Problem with the feeding mechanism. (Refer to Transmit Problem (P.216).)
2	The fax transmits successfully one time and fails another. (Copying is also possible.)	Troubleshooting	Problem with the service line or with the receiver's fax. (Refer to Sometime There is a Transmit Problem (P.217).)
3	The fax receives successfully one time and fails another. (Copying is also possible.)	Troubleshooting	Problem with the service line or with the transmitter's fax. (Refer to Receive Problem (P.218).)
4	The fax completely fails to transmit or receive. (Copying is also possible.)	Troubleshooting	Problem with the electric circuit. (Refer to The Unit Can Copy, But Cannot Transmit/Receive (P.219).)
5	The fax fails either to transmit or receive when making a long distance or an international call. (Copying is also possible.)	Detailed description of the possible causes. (Similar to troubleshooting items No.2 and No.3.)	Problem with the service line.
6	The fax image is poor when transmitting or receiving during a long distance or international call.		
7	No.1-No.5	The troubleshooting procedure for each error code will be printed on the communication result report.	(Refer to How To Output The Journal Report (P.224).)

12.3.9.1. Defective Facsimile Section

12.3.9.1.1. Transmit Problem

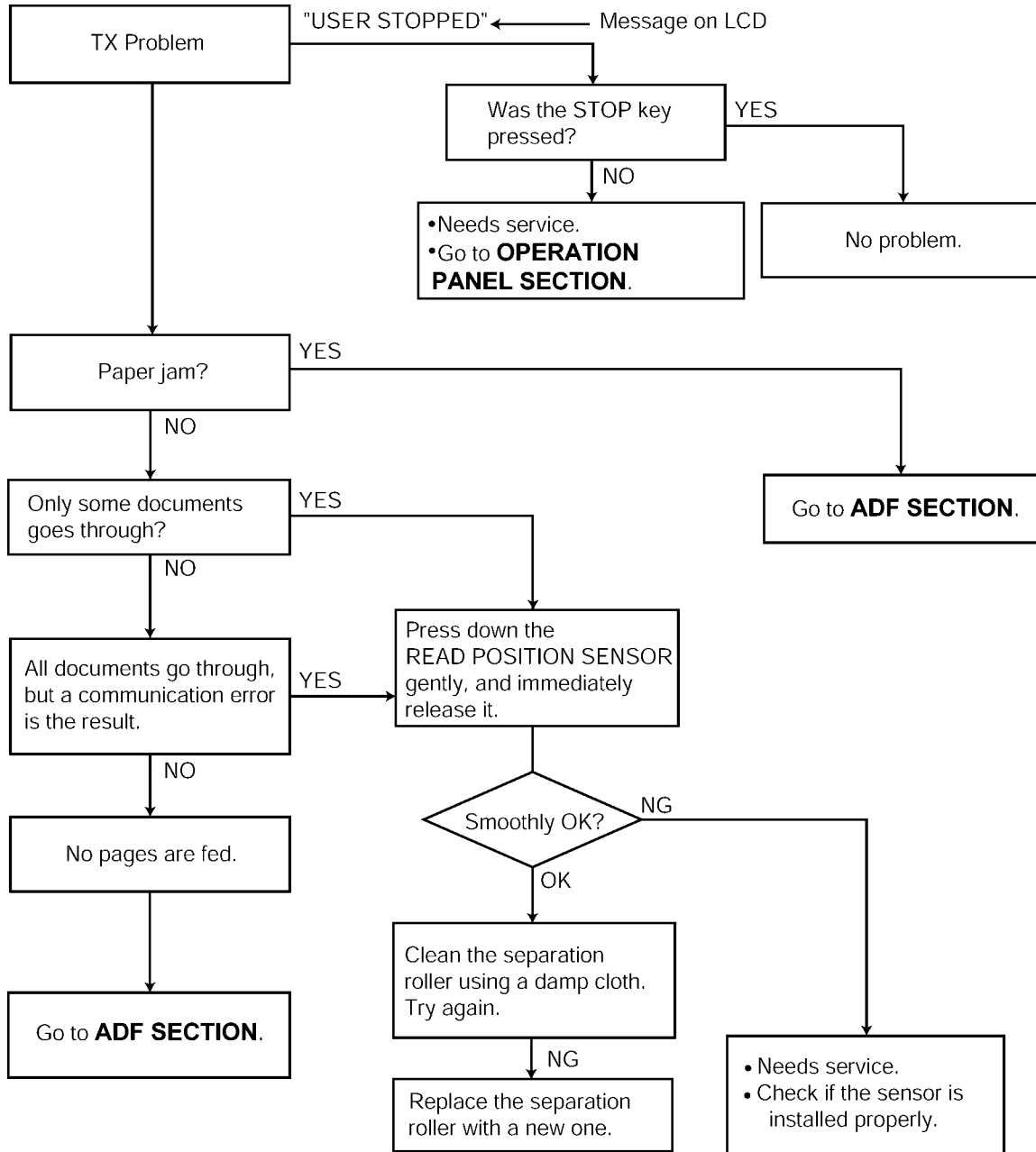

CROSS REFERENCE:

- Operation Panel Section (P.237)
- Cleaning the White Plates and Glass (P.318)
- ADF (Auto document feed) Section (P.209)

12.3.9.1.2. Sometime There is a Transmit Problem

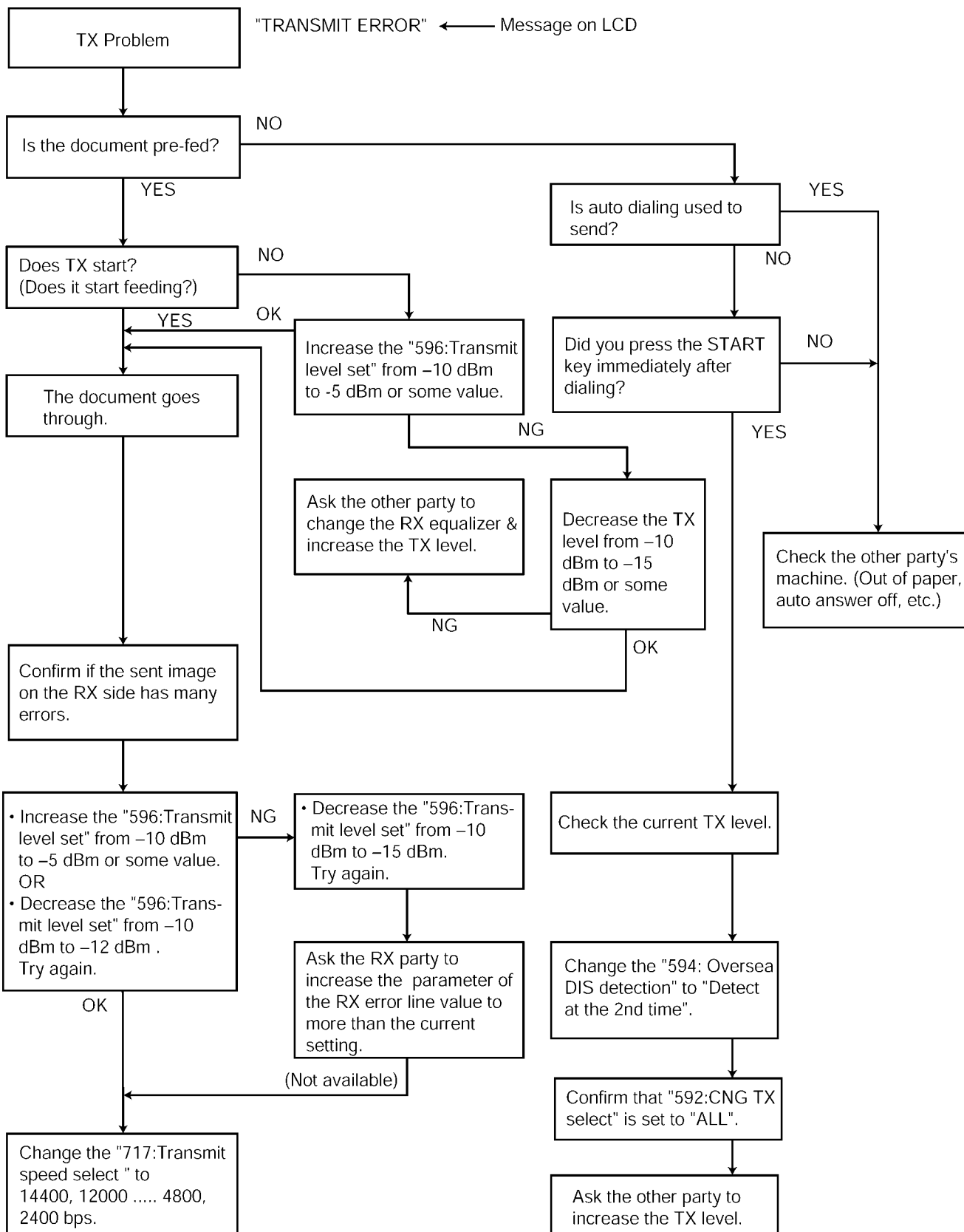

Note:

"596: Transmit level set" represents a service code. Refer to the **Service Function Table** (P.142).

"717: Transmit speed select" represents a service code. Refer to the **Service Function Table** (P.142).

12.3.9.1.3. Receive Problem

Confirm the following before starting troubleshooting.

- Is the recording paper installed properly? Refer to the next page.

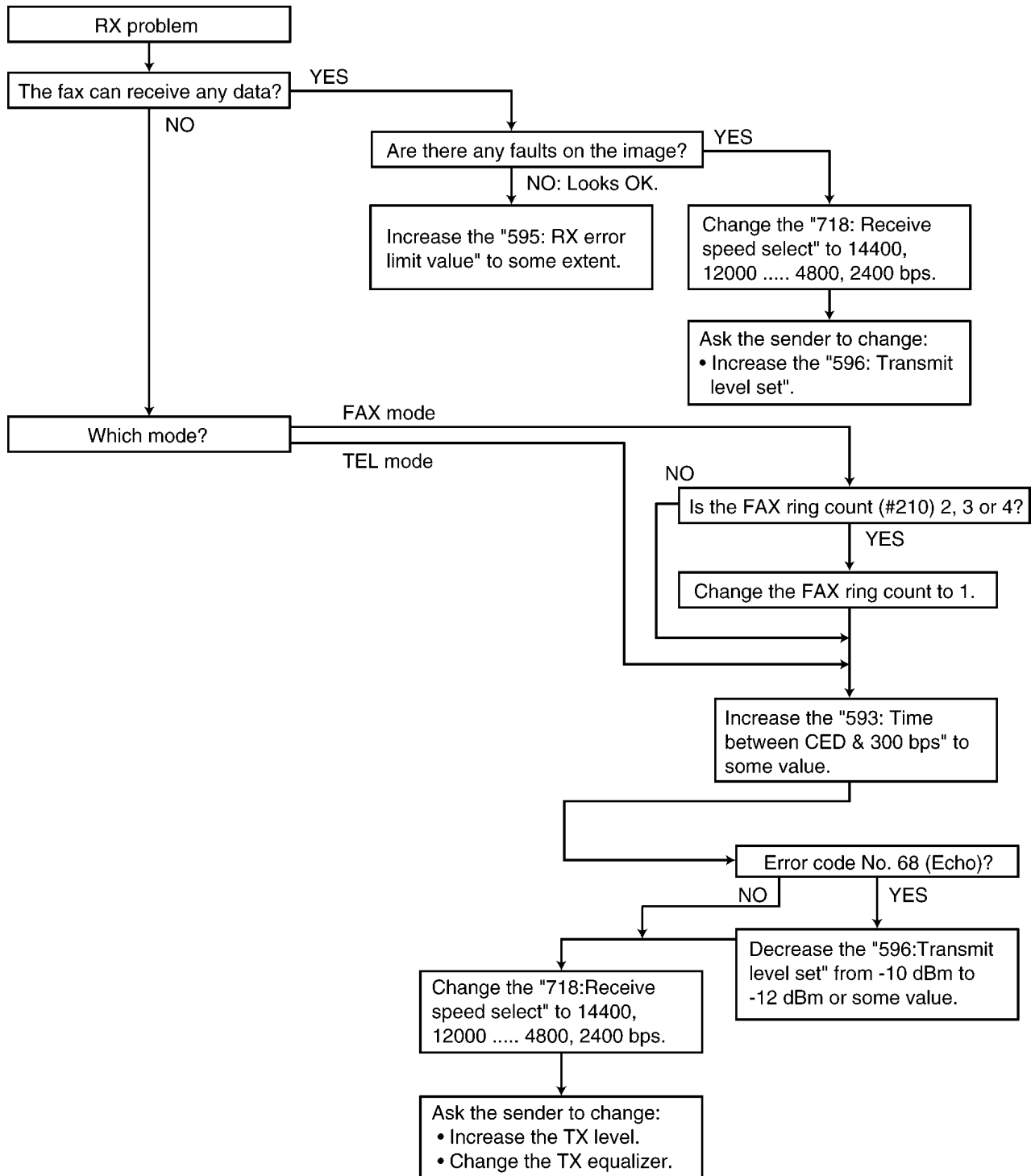

Note:

“596: Transmit level set” represents a service code. Refer to the **Service Function Table** (P.142).

“718: Receive speed select” represents a service code. Refer to the **Service Function Table** (P.142).

For the receiving problem, we have thought of causes other than in the software. Some causes may be when the fax changes to the memory receiving mode (for example, when out of paper). and the memory becomes full of the imprinted fax data. In this case, [MEMORY FULL] and its main cause (for example, “OUT OF PAPER”) are displayed on the LCD. Accordingly, by solving the main problem, [MEMORY FULL] can be canceled and the receiving problem can be solved.

Please refer to **User Recoverable Errors** (P.171) for the above items.

Also, when it actually becomes a hardware deformity, please check each sensor.

12.3.9.1.4. The Unit Can Copy, But Cannot Transmit/Receive

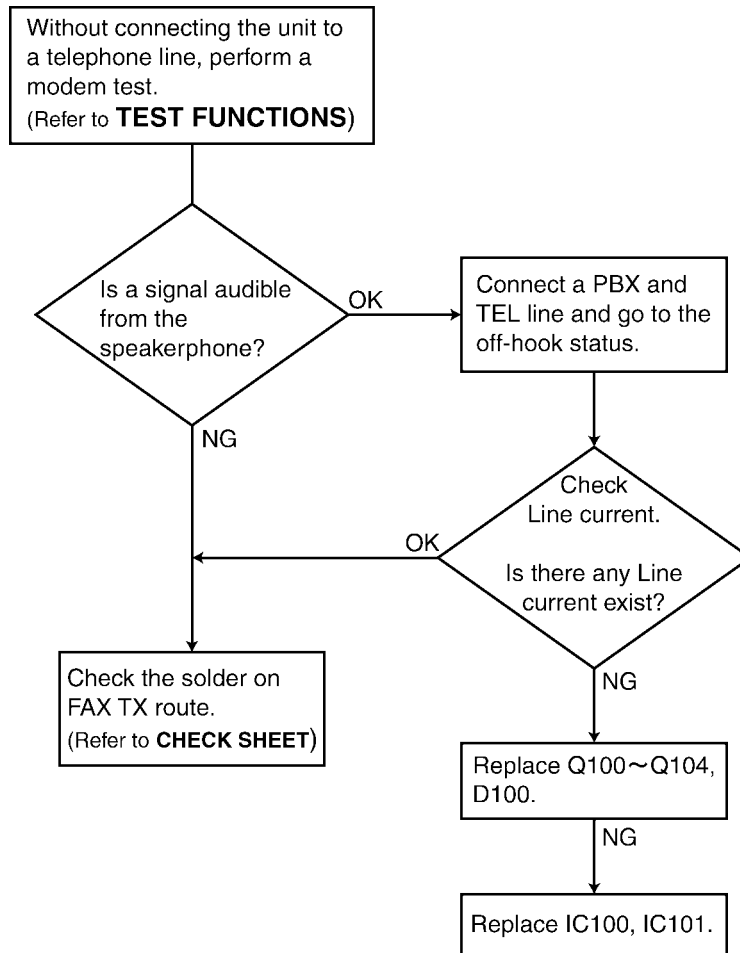

CROSS REFERENCE:
Test Functions (P.136)
Check Sheet (P.234)

12.3.10. Special Service Journal Reports

Journal 2 and Journal 3 shown below, which are special journals giving the additional detailed information about the latest 30 communications, can be printed by Service Code 881 or 882. Remote printing function for the journal reports (JOURNAL, JOURNAL 2 and JOURNAL 3) is also available for service technicians. (Refer to **Program Mode Table (P.177)**.) The JOURNAL report only gives you basic information about a communication, but the other two journal reports provide different information on the same item (communication).

HOW TO READ JOURNAL REPORTS:

Example:

23 Mar. 2002 09:51

YOUR LOGO :
YOUR FAX NO:

NO.	OTHER FACSIMILE	START TIME	USAGE TIME	MODE	PAGES	RESULT	*CODE
01	3332222	21 JAN. 14:14	00'45	SND	001	OK	
02	9998765	21 JAN 15:17	00'58	SND	002	OK	
03	John	21 JAN 15:18	00'48	RCV	001	OK	
04	555556677	22 JAN. 10:35	02'45	RCV	003	COMMUNICATION ERROR	43

23 Mar. 2000 09:51

NO.	(1) RCV MODE	(2) SPEED	(3) RESOLUTION	(4) RCV-TRIG. (CNT.)	(5) ERROR->MEMORY
01	TEL	9600BPS	STD.		
02	TEL	9600BPS	FINE		
03	FAX ONLY	7200BPS	STD.	FAX MOD	
04	FAX ONLY	9600BPS	STD.	CNG (0003)	

NO RESPONSE DISAPPEARED ON JOURNAL

NO.	(1) START TIME	(4) RCV MODE	(4) RCV-TRIG. (CNT.)

YOUR LOGO:
YOUR FAX NO:

23 MAR. 2000 09:51

NO.	(6) ENCODE	(7) MSLT	(8) EQM (RX)	(9) ERROR LINE (RX)	(10) MAKER CODE
01	MH	20msec	0000	00000	79
02	MH	20msec	0000	00000	00
03	MR	20msec	1200	00013	00
04	MR	20msec	0000	00000	00

1. Look at **NO. 01** in the JOURNAL. If you want to know about the details about that item, see **NO. 01** in the JOURNAL 2 and the JOURNAL 3. You can get the following information.

- * MODE: Fax transmission
- * RCV. MODE: TEL
- * TX SPEED: 9.6 kbps
- * RESOLUTION: standard
- * ENCODE: MH
- * MAKER CODE: 79

2. Look at **NO. 04** in the JOURNAL 2. CNG (0003) indicates that the CNG signal has been received three times since the purchase date.

For further details, see **Journal 2** and **Journal 3**.

12.3.10.1. Journal 2

Refer to JOURNAL 2 in **Printout Example** (P.222).

Journal 2 displays the additional detailed information about the last 35 communications.

Descriptions:

(1) RCV. MODE

Indicates which receive mode the unit was in when the unit received a fax message.

This information is also displayed when the unit transmitted a fax message.

(2) SPEED

Indicates the speed of the communication. If multiple pages are transmitted or received, it indicates the last page's communication speed. If there is a communication error, "?" is displayed.

(3) RESOLUTION

Indicates the resolution of the communication. If multiple pages are transmitted or received, it indicates the last page's resolution. If there is a communication error, "?" is displayed.

(4) RCV-TRIG. (CNT.)

Indicates the trigger that causes the unit to switch to the fax receive mode. The available options are listed in JOURNAL 2 in **Printout Example** (P.222). The values in parentheses indicate how many times the trigger has been used. (For example, "00003" means three times.)

No.	Display	Function
1	FAX MODE	Means the unit received a fax message in the FAX mode.
2	MAN RCV	Means the unit received a fax message by manual operation.
3	RMT DTMF	Means the unit detected DTMF (Remote Fax activation code) entered remotely.
4	PAL DTMF	Means the unit detected DTMF (Remote Fax activation code) entered by a parallel connected telephone.
5	TURN-ON	Means the unit started to receive after 10 rings. (Remote Turn On: Service Code #573)

(5) ERROR→MEMORY

Indicates the reason why the unit received a fax message in memory.

If you look at No.11 in the JOURNAL 2 in **Printout Example** (P.222), it shows the fax message was received in memory due to "PICKUP ERR" error.

NO RESPONSE DISAPPEARED ON JOURNAL

The "**NO RESPONSE DISAPPEARED ON JOURNAL**" displays the information about the last 10 communications terminated by "No Response". (Some of the communications terminated by "No Response" were not displayed in the JOURNAL.)

When a fax transmission cannot be performed because the other party's unit is set to the TEL mode, "No response" will be printed.

12.3.10.2. Journal 3

Refer to JOURNAL 3 in **Printout Example** (P.222).

Description

(6) ENCODE

Compression Code: MH/MR/MMR

(7) MSLT

MSLT means Minimum Scan Line Time. Used only at the factory.

(8) EQM (RX)

EQM means Eye Quality Monitor. Used only at the factory.

(9) ERROR LINE (RX)

When an error occurs while receiving a fax, this shows the number of error lines.

(10) MAKER CODE

This shows a 2 digit code of the other party's fax machine brand.

0E: "KX" model

00: Unknown

79: "UF" model

19: "Xerox" model

12.3.10.3. Printout Example

JOURNAL 2

06 Jan. 2011 19:08

NO.	RCV MODE	SPEED	RESOLUTION	RCV-TRIG. (CNT.)	ERROR->MEMORY
01	FAX ONLY	V34-336 (-22dBm)	STD.	FAX MOD(00002)	
02	FAX ONLY	V34-336 (-22dBm)	STD.	FAX MOD(00003)	
03	FAX ONLY	V34-336 (-22dBm)	STD.	FAX MOD(00004)	
04	FAX ONLY	V34-336 (-22dBm)	STD.	FRN RCV(00001)	
05	FAX ONLY	V34-336 (-18dBm)	STD.		
06	FAX ONLY	V34-336 (-22dBm)	STD.	MAN RCV(00001)	
07	FAX ONLY	V34-336 (-22dBm)	STD.	FAX MOD(00005)	
08	FAX ONLY	V34-336 (-22dBm)	STD.	FAX MOD(00006)	
09	FAX ONLY	V34-336 (-22dBm)	STD.	FAX MOD(00007)	
10	FAX ONLY	V34-336 (-22dBm)	STD.	FAX MOD(00008)	
11	FAX ONLY	V34-336 (-22dBm)	STD.	FAX MOD(00009)	PICKUP ERR
12	TEL	V34-336 (-22dBm)	STD.	MAN RCV(00002)	
13	TEL	V34-336 (-22dBm)	STD.	TURN-ON(00001)	
14	TEL	V34-336 (-22dBm)	STD.	TURN-ON(00002)	
15	TEL	V34-336 (-22dBm)	STD.	TURN-ON(00003)	
16	TEL	V34-336 (-22dBm)	STD.	TURN-ON(00004)	
17	TEL	V34-336 (-22dBm)	STD.	TURN-ON(00005)	
18	TEL	V34-336 (-22dBm)	STD.	TURN-ON(00006)	
19	TEL	V34-336 (-22dBm)	STD.	TURN-ON(00007)	
20	TEL	V34-336 (-22dBm)	STD.	TURN-ON(00008)	
21	TEL	V34-336 (-22dBm)	STD.	TURN-ON(00009)	
22	TEL	V34-336 (-22dBm)	STD.	TURN-ON(00010)	
23	TEL	V34-336 (-22dBm)	STD.	TURN-ON(00011)	
24	TEL	V34-336 (-22dBm)	STD.	TURN-ON(00012)	
25	TEL	V34-336 (-22dBm)	STD.	TURN-ON(00013)	
26	TEL	V34-336 (-22dBm)	STD.	TURN-ON(00014)	
27	TEL	V34-336 (-22dBm)	STD.	TURN-ON(00015)	
28	TEL	V34-336 (-22dBm)	STD.	TURN-ON(00016)	
29	FAX ONLY	V34-336 (-22dBm)	STD.	FAX MOD(00010)	
30	FAX ONLY	V34-336 (-22dBm)	STD.	FAX MOD(00011)	

NO RESPONSE DISAPPEARED ON JOURNAL

NO.	START TIME	RCV MODE	RCV-TRIG. (CNT.)
YOUR LOGO	:		
YOUR FAX NO.	:		

JOURNAL3

09 Sep. 2007 14 : 18

NO.	ENCODE	MSLT	EQM (RX)		ERROR LINE (RX)	MAKER CODE
01	MMR	0msec	0000		00000/00000	0E
02	MMR	0msec	0000		00000/00000	0E
03	MMR	0msec	0000		00000/00000	00
04	MMR	0msec	0000		00000/00000	0E
05	MMR	0msec	0000		00000/00000	0E
06	MH	20msec	0000		00000/00000	00
07	MH	20msec	0000		00000/00000	00
08	MH	20msec	0000		00000/00000	00
09	MH	20msec	0000		00000/00000	00
10	MH	20msec	0000		00000/00000	00
11	MMR	0msec	0000		00000/00000	0E
12	MMR	0msec	0000		00000/00000	0E
13	MMR	0msec	0000		00000/00000	0E
14	MMR	0msec	0000		00000/00000	0E
15	MMR	0msec	0000		00000/00000	0E
16	MMR	0msec	1600	SNR=38dB	00000/04606	0E
17	MMR	0msec	0000		00000/00000	0E
18	MMR	0msec	0000		00000/00000	0E
19	MMR	0msec	0000		00000/00000	0E
20	MMR	0msec	0000		00000/00000	0E
21	MMR	0msec	0000		00000/00000	0E
22	MMR	0msec	0000		00000/00000	0E
23	MMR	0msec	0000		00000/00000	0E
24	MMR	0msec	0000		00000/00000	0E
25	MMR	0msec	0000		00000/00000	0E
26	MMR	0msec	0000		00000/00000	0E
27	MMR	0msec	0000		00000/00000	0E
28	MMR	0msec	0000		00000/00000	0E
29	MMR	0msec	0000		00000/00000	0E
30	MMR	0msec	0000		00000/00000	0E

12.3.10.4. How To Output The Journal Report

1. Press the MENU button 4 times.
2. Press “#”, then “2”.
3. Press the SET button.
4. The report prints out.

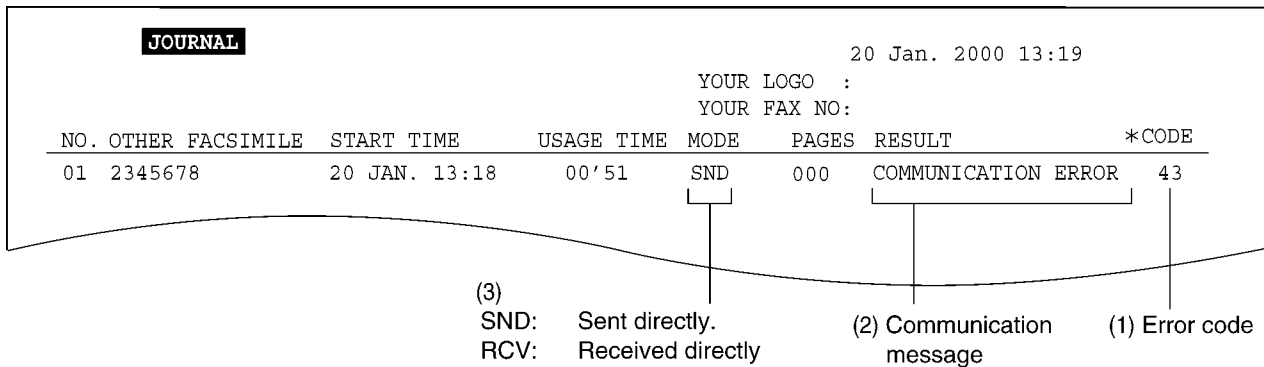

CROSS REFERENCE:
Features (P.28)

Error code table:

(1) CODE	(2) RESULT	(3) MODE	SYMPTOM	Counter-measure*
	PRESSED THE STOP KEY	SND & RCV	Communication was interrupted by the STOP button.	
	DOCUMENT JAMMED	SND	The document paper is jammed.	
	NO DOCUMENT	SND	No document paper.	
	THE COVER WAS OPENED	SND	The cover is open.	
28	COMMUNICATION ERROR	SND	Invalid signal is received during PHASE-B of PHASE-D.	
40	COMMUNICATION ERROR	SND	Transmission is finished when the T0 TIMER expires.	1
41	COMMUNICATION ERROR	SND	DCN is received after DCS transmission.	2
42	COMMUNICATION ERROR	SND	FTT is received after transmission of a 2400BPS training signal.	3
43	COMMUNICATION ERROR	SND	No response after post message is transmitted three times.	4
44	COMMUNICATION ERROR	SND	RTN and PIN are received.	5
46	COMMUNICATION ERROR	RCV	No response after FTT is transmitted.	6
48	COMMUNICATION ERROR	RCV	No post message.	7
49	COMMUNICATION ERROR	RCV	RTN is transmitted.	8
50	COMMUNICATION ERROR	RCV	PIN is transmitted (to PRI-Q).	8
51	COMMUNICATION ERROR	RCV	PIN is transmitted.	8
52	COMMUNICATION ERROR	RCV	Reception is finished when the T0 TIMER expires.	9
54	ERROR-NOT YOUR UNIT	RCV	DCN is received after DIS transmission.	11
58	COMMUNICATION ERROR	RCV	DCN is received after FTT transmission.	13
59	ERROR-NOT YOUR UNIT	SND	DCN responds to the post message.	14
65	COMMUNICATION ERROR	SND	DCN is received before DIS reception.	2
65	COMMUNICATION ERROR	RCV	Reception is not EOP, EOM PIP, PIN, RTP or RTN.	2
68	COMMUNICATION ERROR	RCV	No response at the other party after MCF or CFR is transmitted.	13
70	ERROR-NOT YOUR UNIT	RCV	DCN is received after CFR transmission.	13
72	COMMUNICATION ERROR	RCV	Carrier is cut when the image signal is received.	16
75	MEMORY FULL	RCV	The document was not received due to memory full.	
79	CANCELED	SND	The multi-station transmission was rejected by the user.	
FD	COMMUNICATION ERROR	SND & RCV	Modem error. For the DCN, DCN, etc. abbreviations, refer to NCU Section (Fax supported models only) (P.47). ITS (Integrated telephone System) and Monitor Section (Fax supported models only) (P.48).	12

SND=TRANSMISSION / RCV=RECEPTION

Most fax communication problems can be resolved by the following steps.

1. Change the transmit level. (Service code: 596, refer to **Service Function Table (P.142).**)
2. Change the TX speed/RX speed. (Service code: 717/718, refer to **Service Function Table (P.142).**)

Note*:

If the problem remains, see the following “Countermeasure” flow chart.

Countermeasure

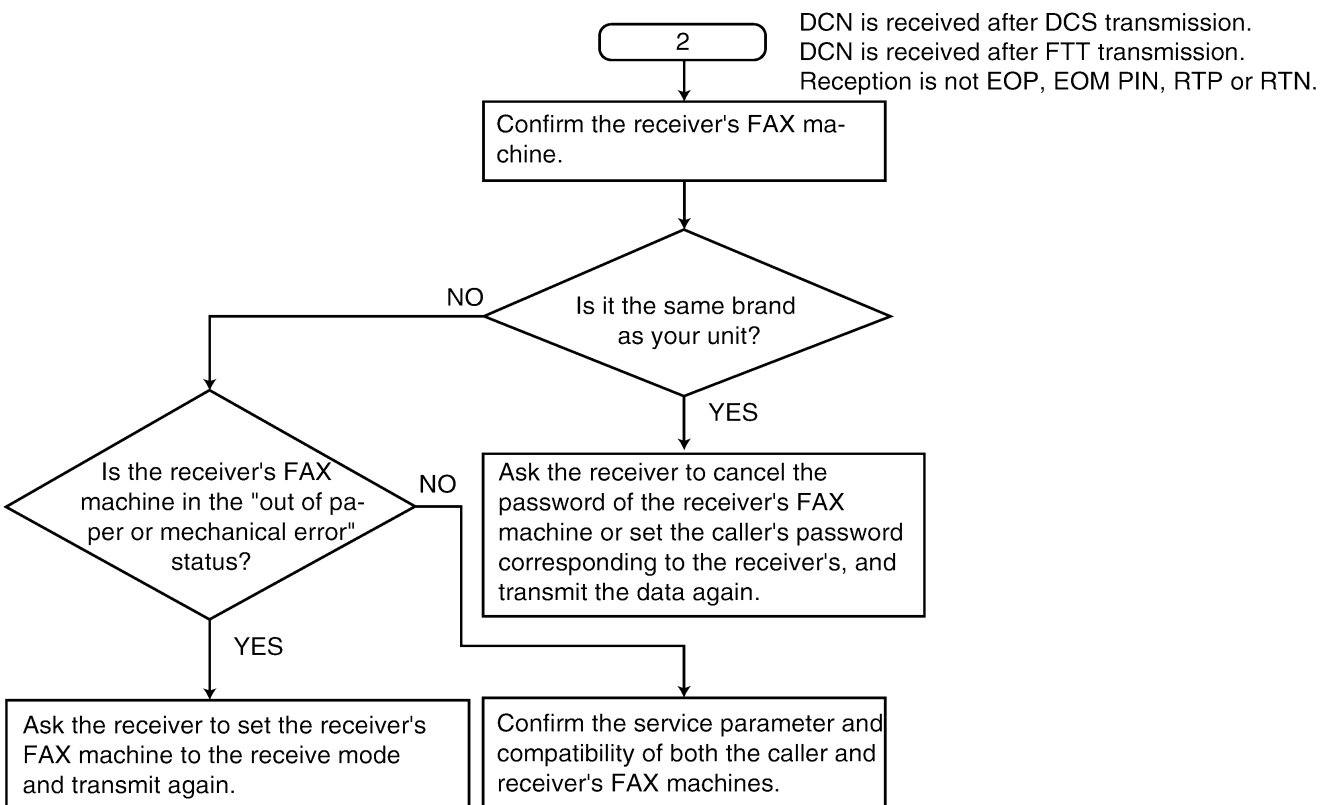
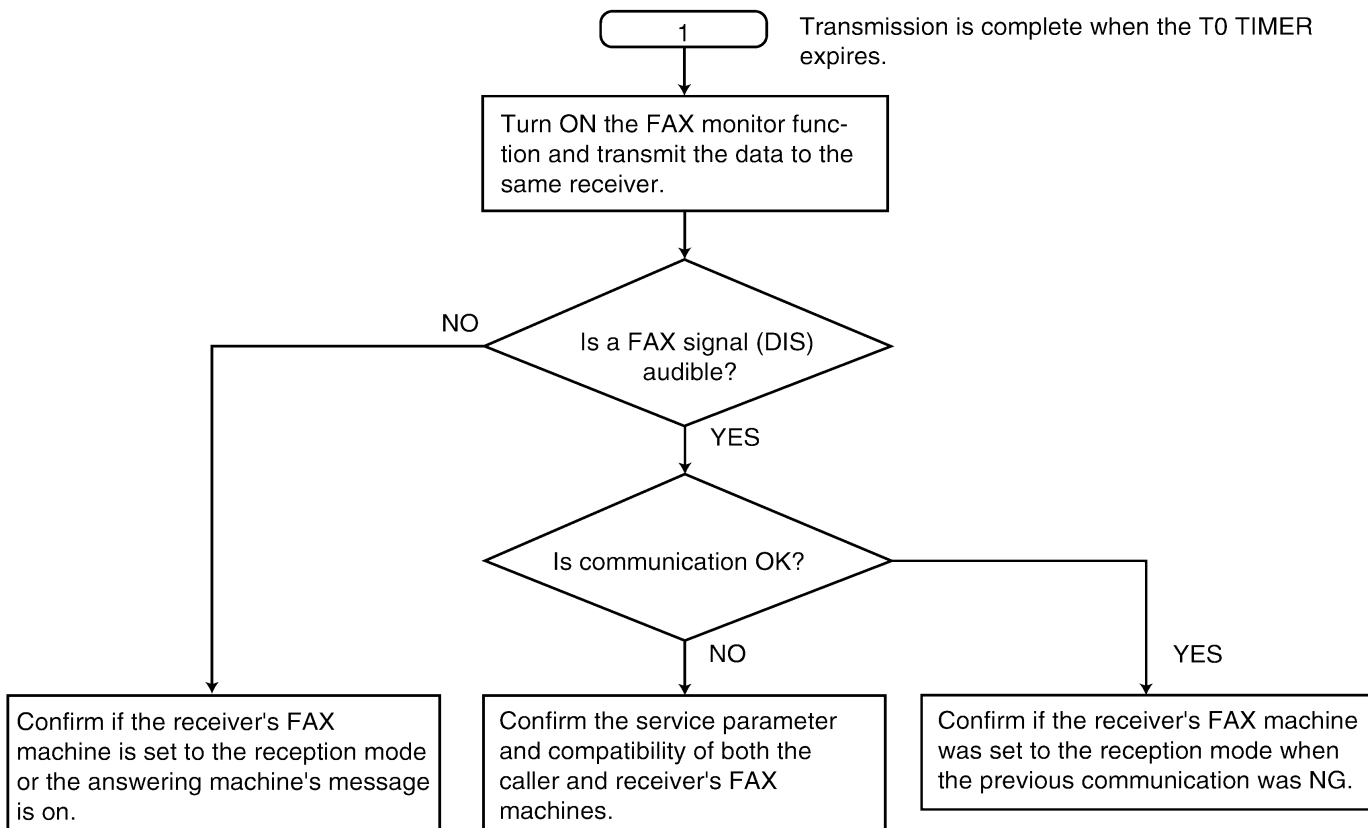

- FTT is received after the transmission of the 2400BPS training signal.
- DCN is received before DIS reception.
- Reception is not EOP, EOM PIP, PIN, RTP or ETN.

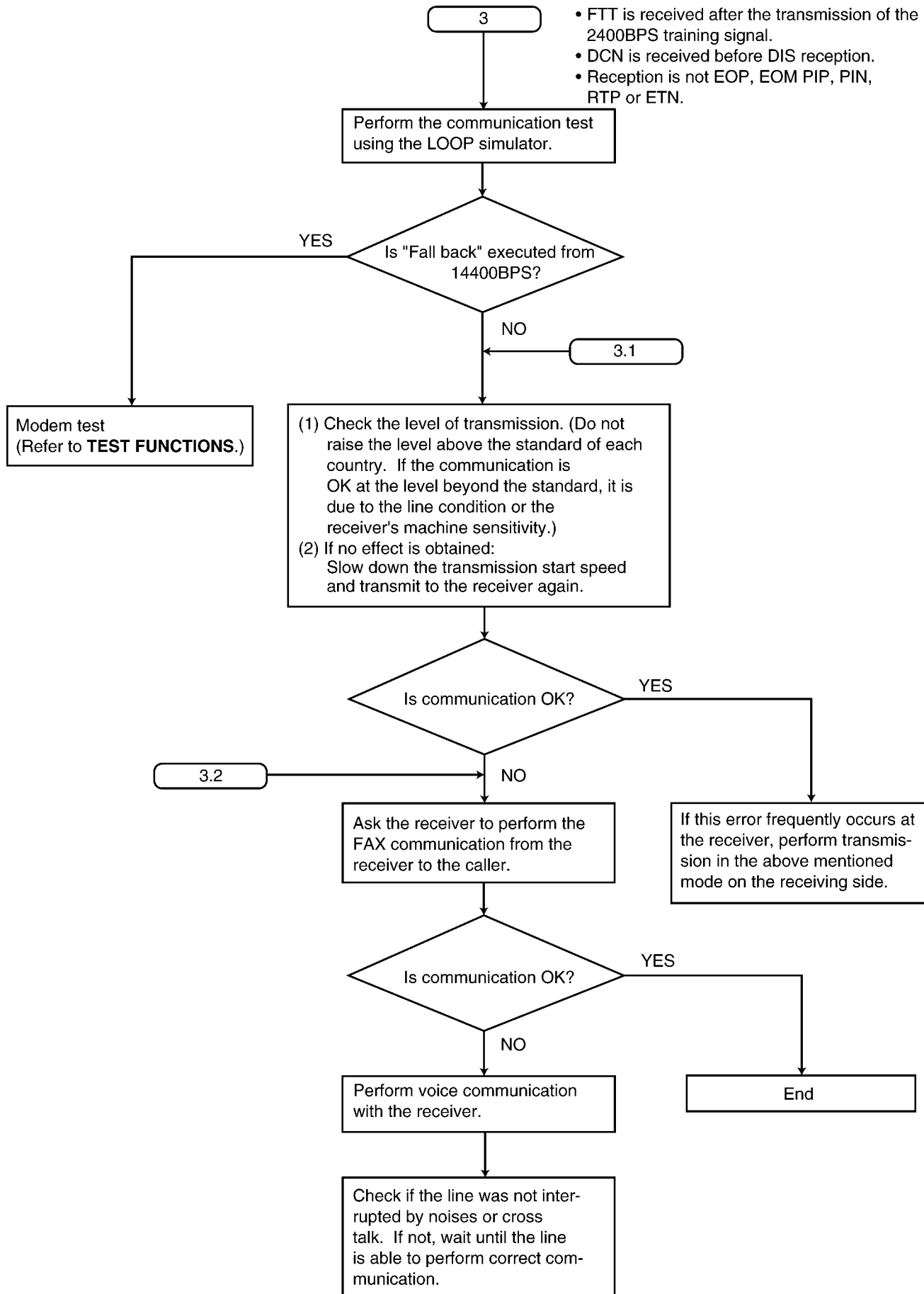

CROSS REFERENCE:
Test Functions (P.136)

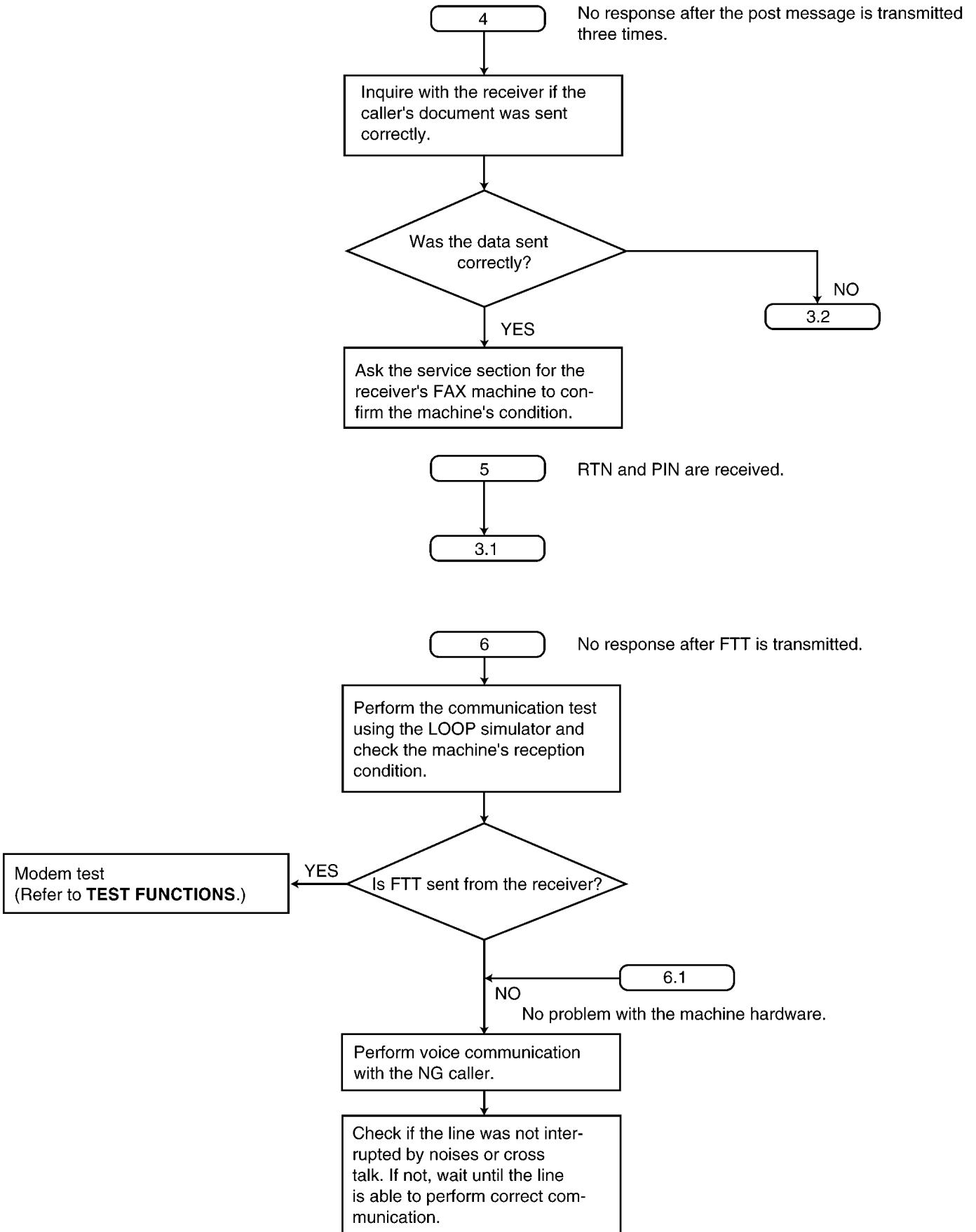

CROSS REFERENCE:
Test Functions (P.136)

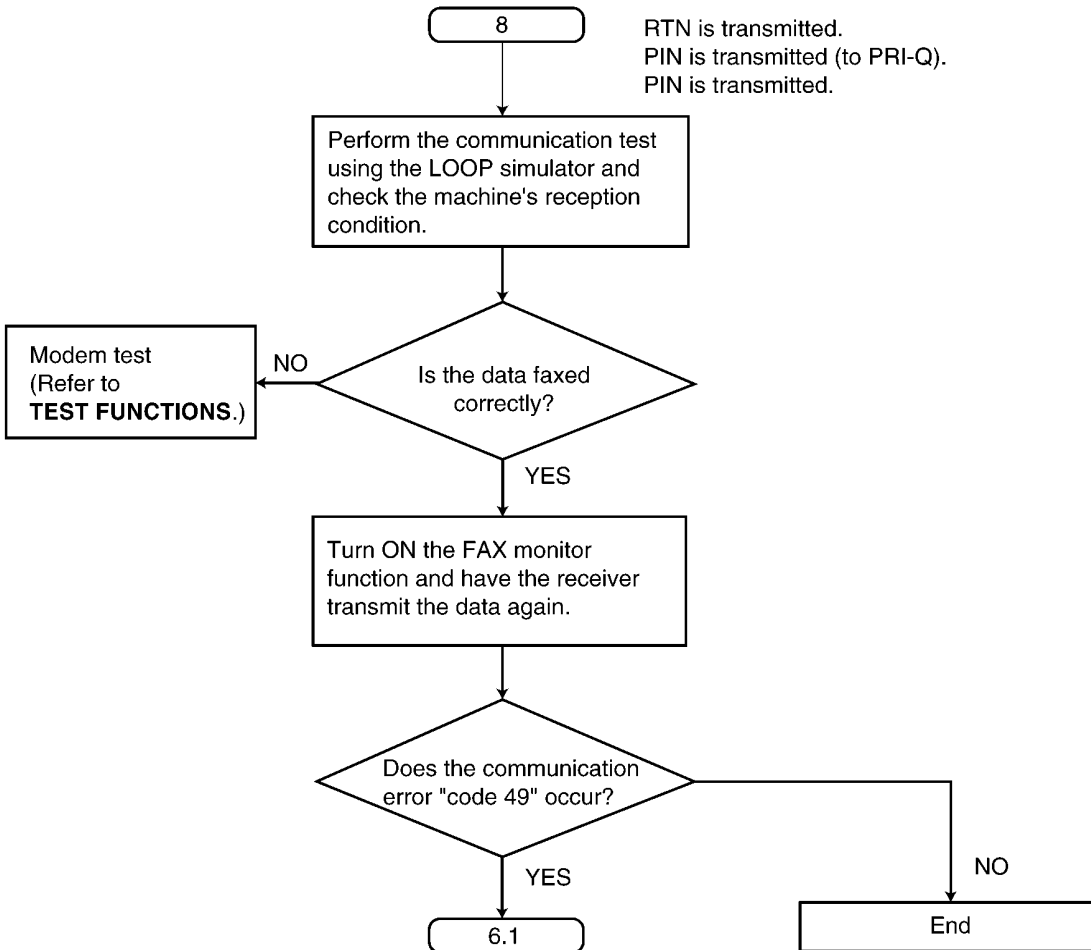
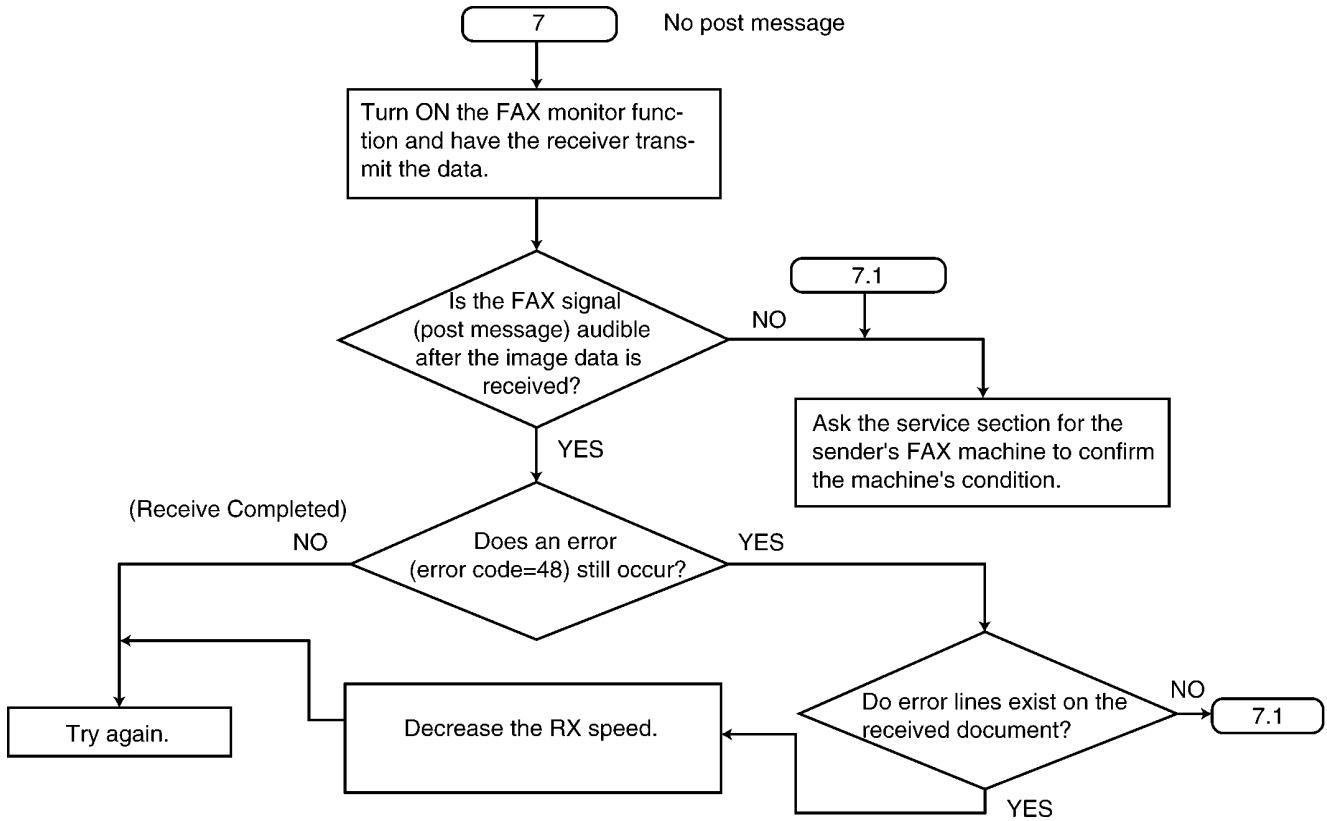

CROSS REFERENCE:
Test Functions (P.136)

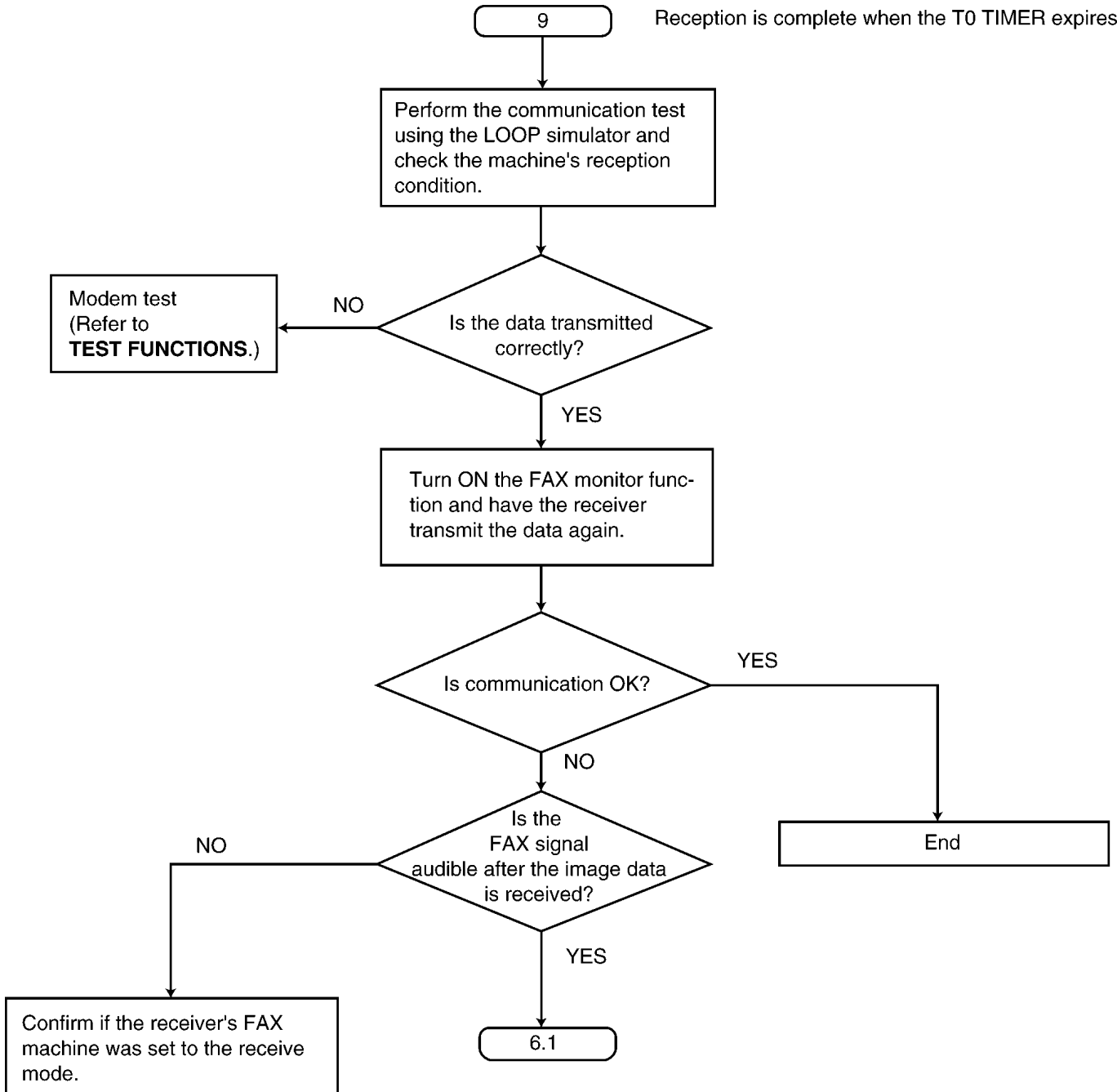

CROSS REFERENCE:
Test Functions (P.136)

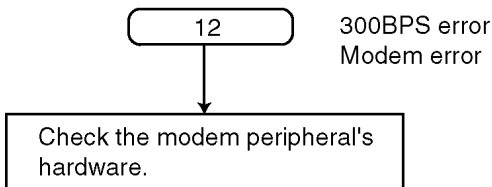
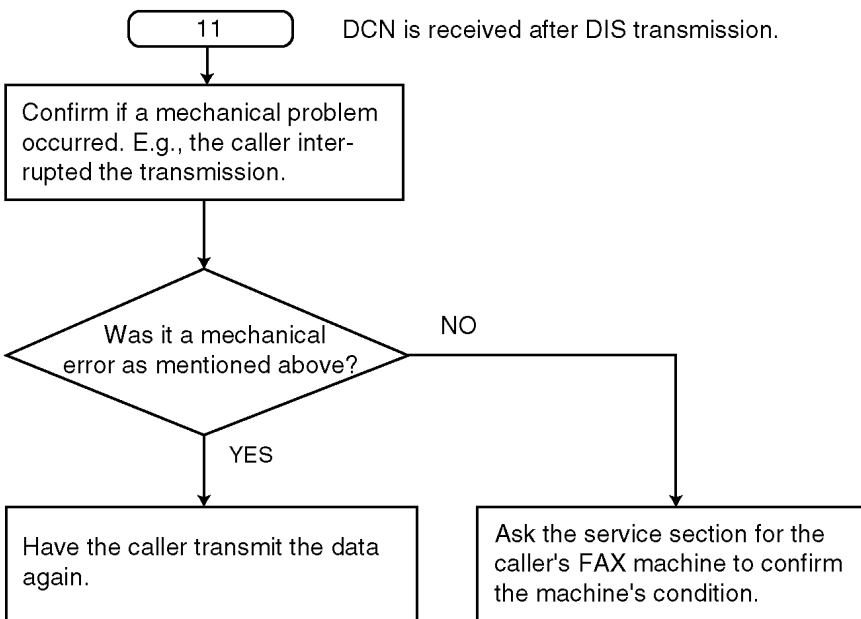
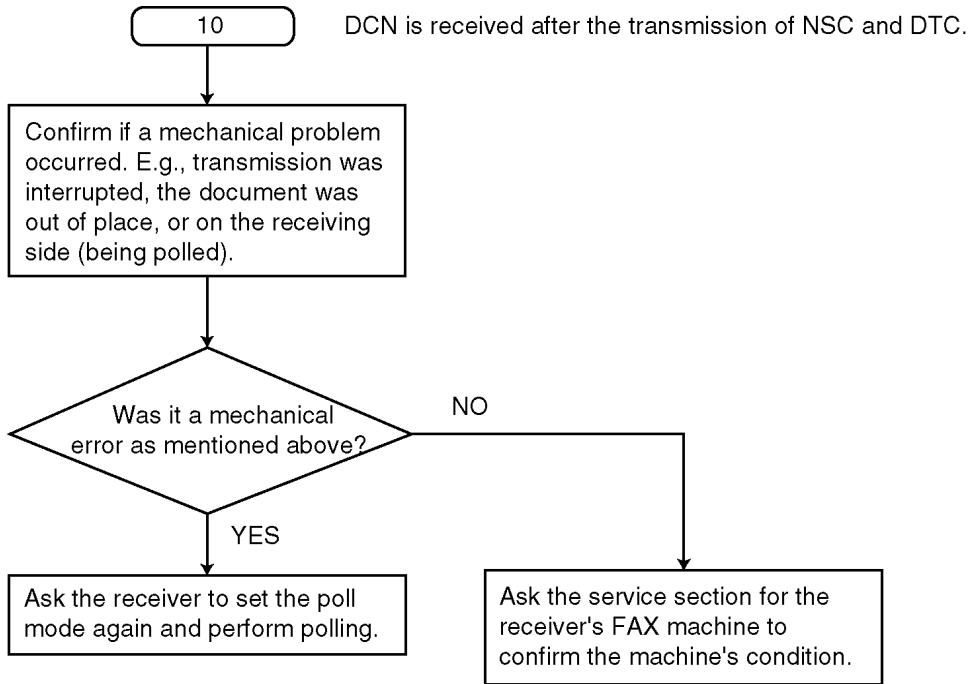

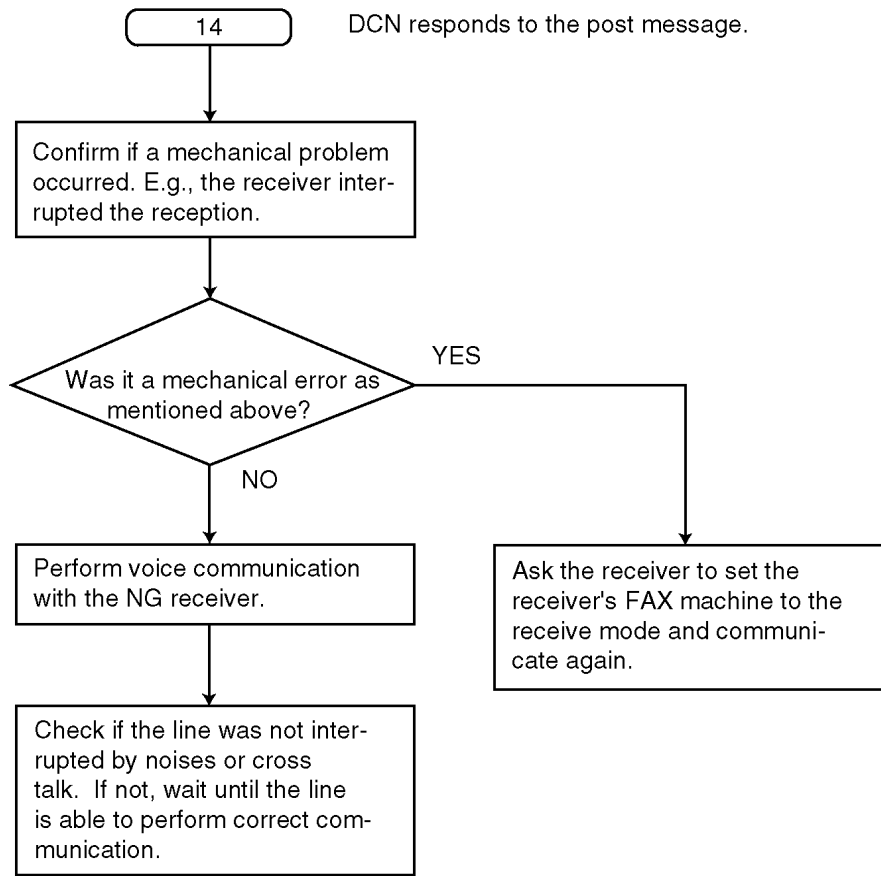
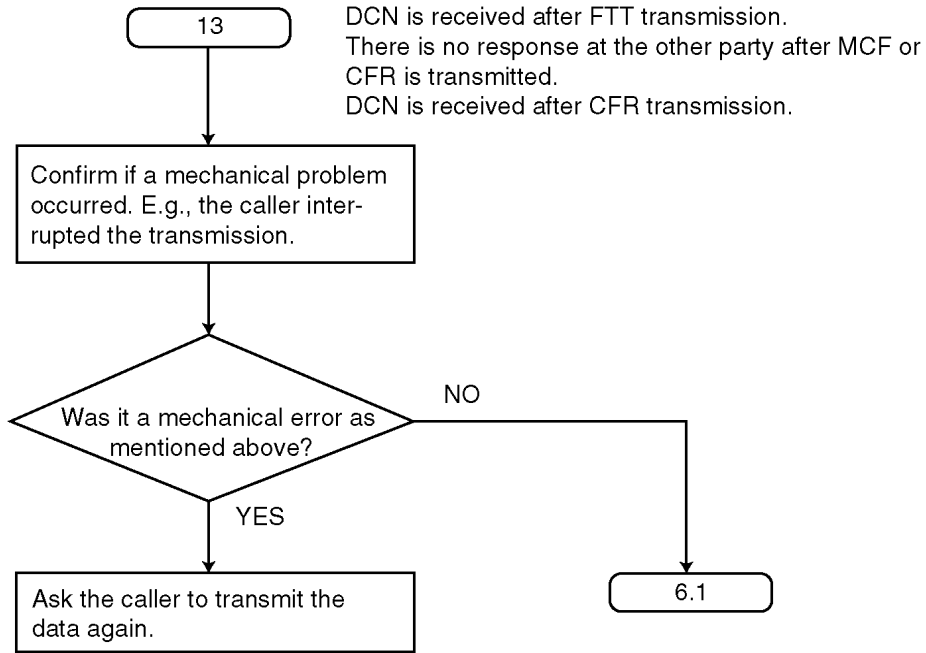

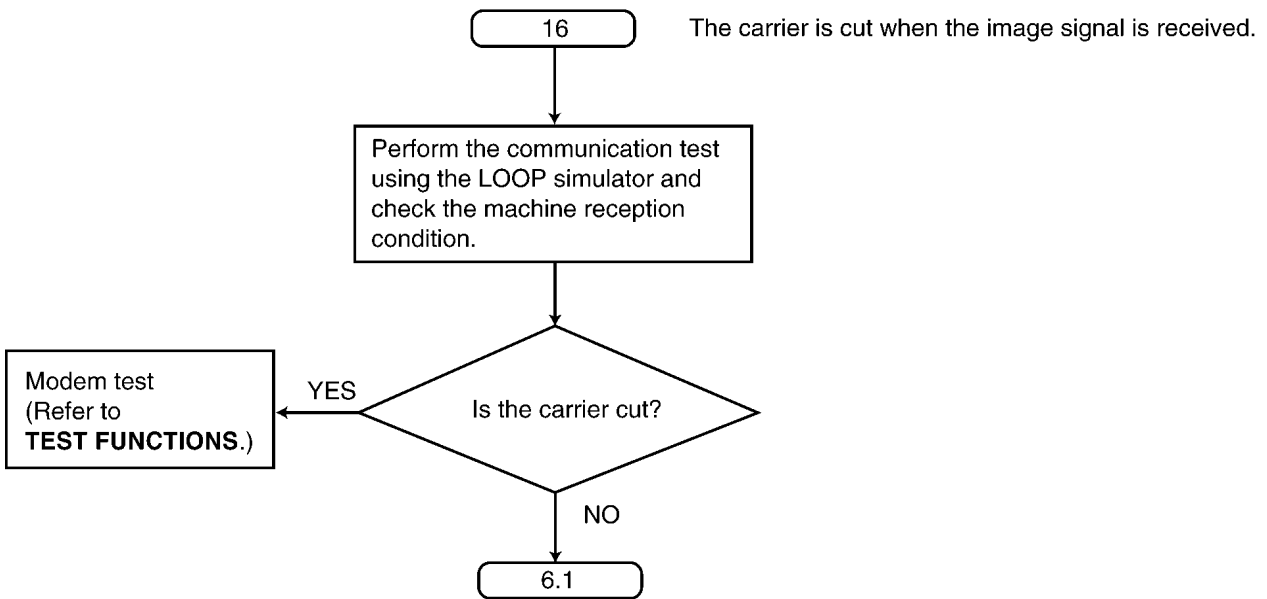
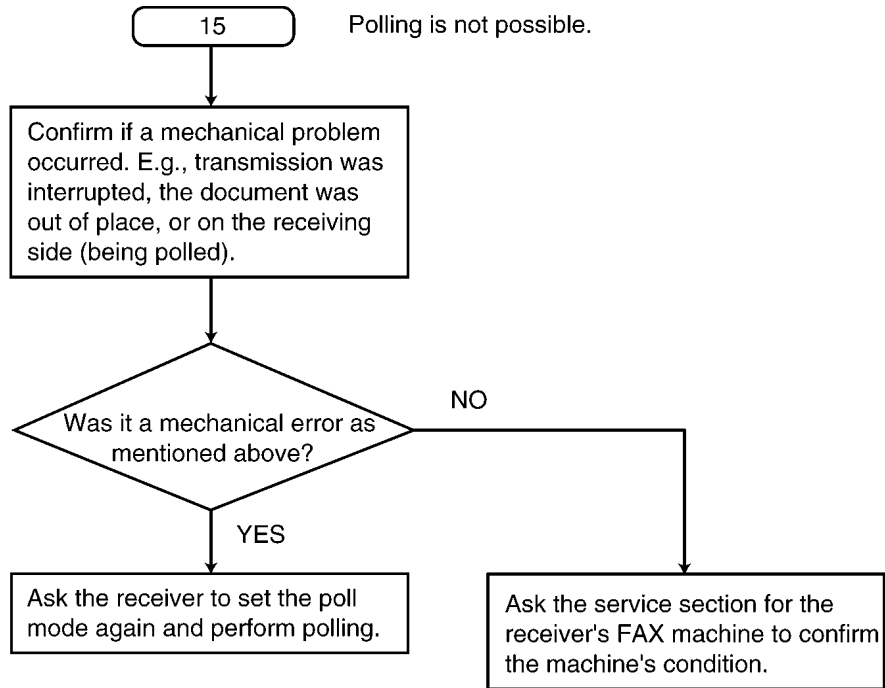

CROSS REFERENCE:
Test Functions (P.136)

12.3.11. Initializing Error

After the power is turned on, the SOC (IC300) initializes and checks each IC.

The ROM (IC402) and SDRAM (IC400/401) are checked.

If initialization fails for the ICs, the system will not boot up.

In this case, please find the cause as follows.

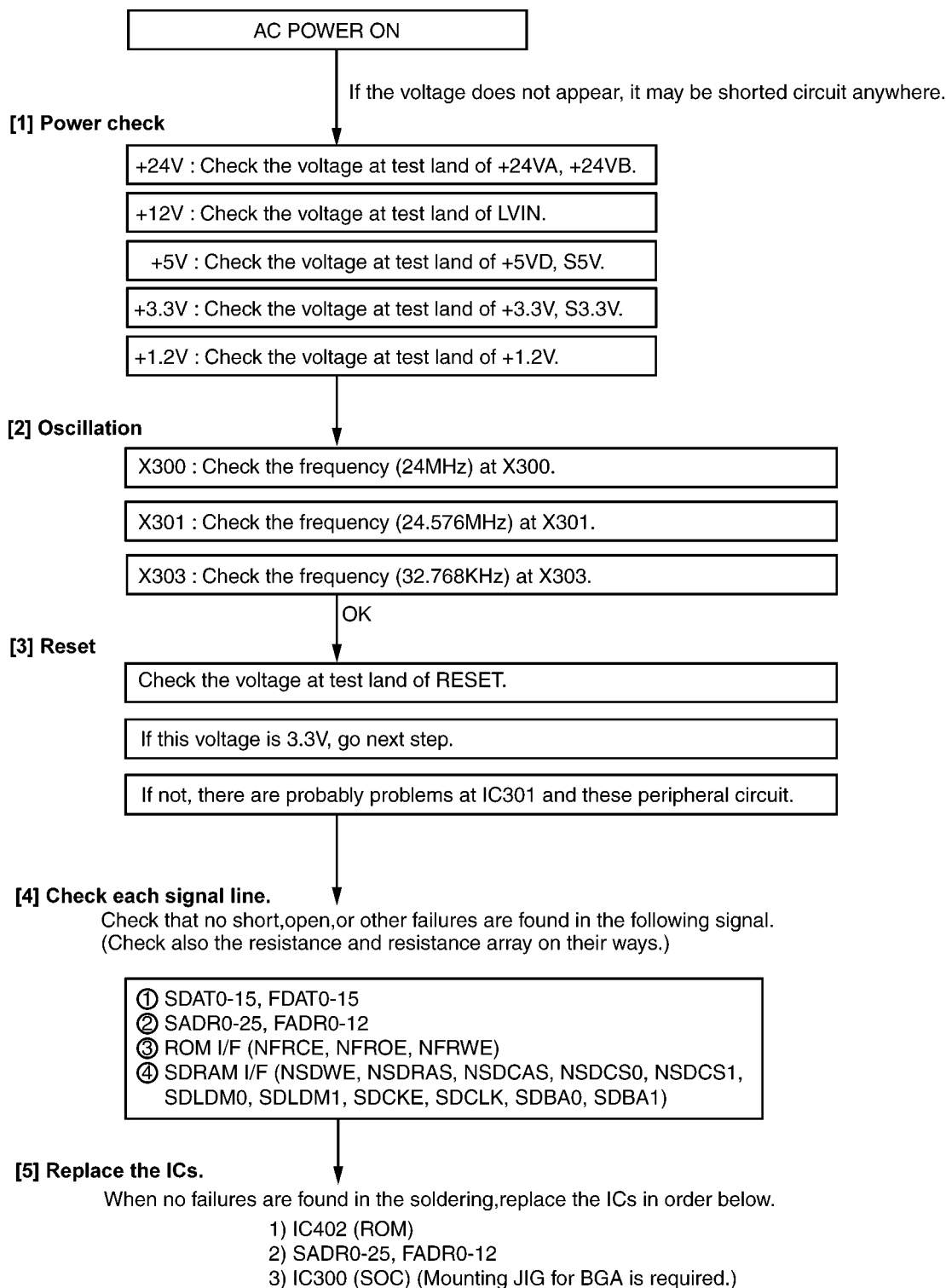

CROSS REFERENCE:

NG Example (P.334)

Power Supply Board Section (P.106)

12.3.12. Analog Section (Fax supported models only)

This chapter provides the testing procedures required for the analog parts. A signal route to be tested is determined depending upon purposes. For example, the MicTX route begins at the microphone and the signal is output to the telephone line. The signal mainly flowing on this route is analog. You can trace the signal with an oscilloscope. The signal flow on each route is shown in the Check Sheet here. If you find a specific problem in the unit, for example if you cannot communicate with the Mic/Speaker, trace that signal route locally with the following Check Sheet and locate the faulty point.

12.3.12.1. Check Sheet

(SYMPTOM) CHECK ITEMS	Signal ROUTE	
	IN	OUT
MONITOR RX	TEL LINE-CN100(3,4)-F100(or POS100 ^{*2})-L110-L106&L107-L105&L104-R119-D101-Q100&Q101&Q102 &Q103&Q104&C105&C106&C107&C110&C111&C112&C113&R104&R105&R108&R111&R112&R113 &R114&R115&R116&R122&D100-IC101-C103&C104-R102&R103-L100&L101-IC100-IC300-IC201- C206-R212-R216-C212-L214-R229&C229-L210&L211-CN201-Speaker	
HANDSET TX ^{*1}	MIC - CN200(3,4)-L212&L213-R231&R232-C230&C231-L205&L206-IC200- R222&C219-R208-C205-L202-IC201-IC300-IC100-L100&L101-R102&R103-C103&C104- IC101-Q100&Q101&Q102&Q103&Q104&C105&C106&C107&C110&C111&C112&C113&R104&R105& R108&R111&R112&R113&R114&R115&R116&R122&D100-D101-R119-L105&L104-L106&L107-L110- F100(or POS100 ^{*2})-CN100(3,4)-TEL LINE	
HANDSET RX ^{*1}	TEL LINE-CN100(3,4)-F100(or POS100 ^{*2})-L110-L106&L107-L105&L104-R119-D101-Q100&Q101&Q102 &Q103&Q104&C105&C106&C107&C110&C111&C112&C113&R104&R105&R108&R111&R112&R113 &R114&R115&R116&R122&D100-IC101-C103&C104-R102&R103-L100&L101-IC100-IC300-IC201- C208-R214-L203-IC200-R218&C216-C217-R219-R221-C218-Q202-C224-R230-CN200(5,6)-HS Speaker	
DTMF Monitor	Speaker	IC300-IC201-C206-R212-R216-C212-L214-R229&C229-L210&L211-CN201-Speaker
	Handset ^{*1}	IC300-IC201-C208-R214-L203-IC200-R218&C216-C217-R219-R221-C218-Q202-C224-R230-CN200(5,6) -HS Speaker
DTMF for TEL Line FAX Tx	IC300-IC100-L100&L101-R102&R103-C103&C104-IC101-Q100&Q101&Q102&Q103&Q104&C105&C106 &C107&C110&C111&C112&C113&R104&R105&R108&R111&R112&R113&R114&R115&R116&R122& D100-D101-R119-L105&L104-L106&L107-L110-F100(or POS100 ^{*2})-CN100(3,4)-TEL LINE	
Ringin/Alarm/ Beep/Key tones	IC300-C207-R213-L214-IC203-R229&C229-L210&L211-CN200-Speaker	
CNG/DTMF detection (ON-HOOK)	TEL LINE-CN100(3,4)-F100(or POS100 ^{*2})-L110-L106&L107-L102&L103-R109&R110&C108&C109-R106& R107-IC101/L105&L104-R119-D101-IC101-C103&C104-R102&R103-L100&L101-IC100-IC300	
Caller ID detection		
BELL detection		
FAX Rx	TEL LINE-CN100(3,4)-F100(or POS100 ^{*2})-L110-L106&L107-L105&L104-R119-D101-Q100&Q101&Q102& Q103&Q104&C105&C106&C107&C110&C111&C112&C113&R104&R105&R108&R111&R112&R113& R114&R115&R116&R122&D100-IC101-C103&C104-R102&R103-L100&L101-IC100-IC300	

^{*1} H/S models only

^{*2} EU, JT, CX use F100. Others use POS100.

12.3.12.2. Detective ITS (Integrated Telephone System) Section

1. No Speakerphone Transmission / Reception

Perform a signal test in the **ITS or the NCU section** and locate a defective point (where the signal disappears) on each route between the microphone and the telephone line (sending), or between the telephone line and the speaker (receiving). Check the components at that point. **Check Sheet**(P.234) is useful for this investigation.

2. No Pulse Dialing

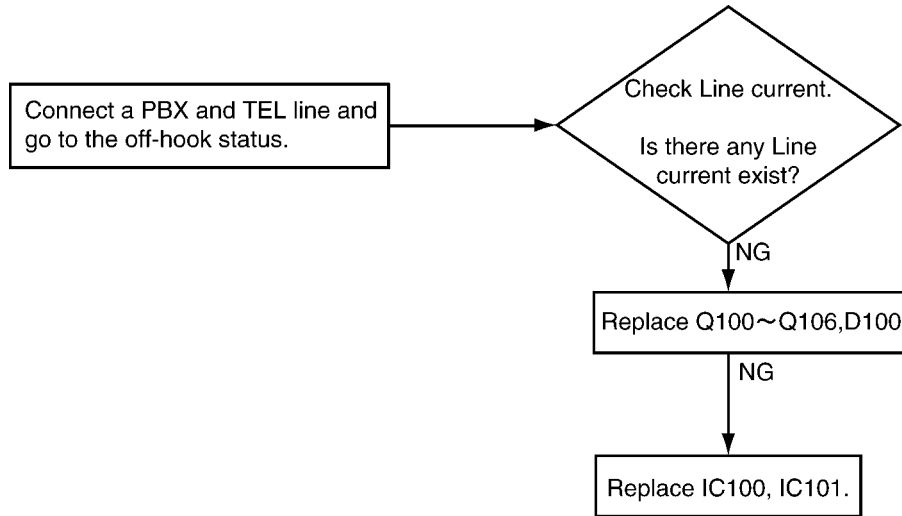

3. No Ring Tone (or No Bell)

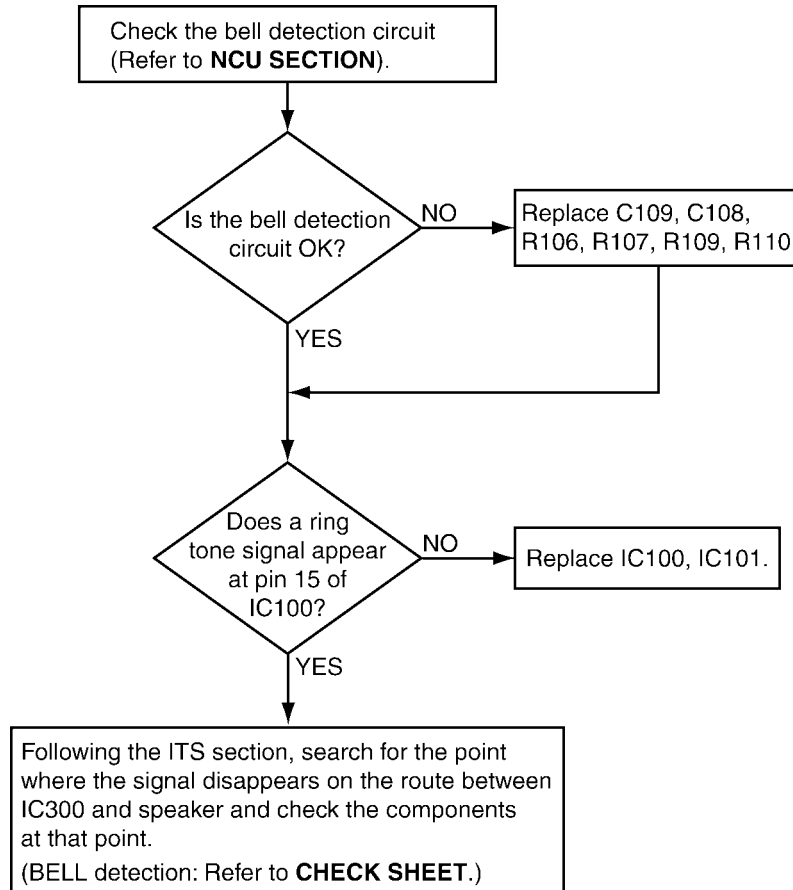

CROSS REFERENCE:

Check Sheet (P.234)

NCU Section (Fax supported models only) (P.47)

4. No Tone Dialing

Following the NCU section and ITS section, search for the point where the signal disappears on the route the telephone jack and check the components at that point.
(DTMF for TEL LINE: Refer to **CHECK SHEET.**)

CROSS REFERENCE:
Check Sheet (P.234)

12.3.12.3. Detective TAM Interface Section

1. The FAX turns on, but does not arrive through TAM.

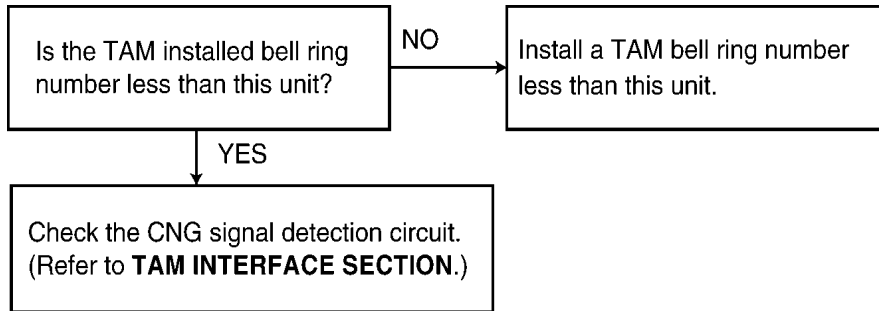

CROSS REFERENCE:
TAM Interface Circuit (P.47)

2. A FAX is received, but won't switch from TAM to FAX.

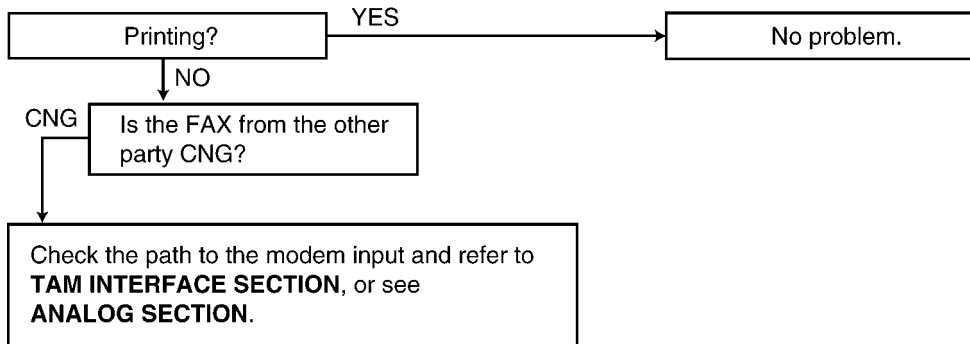

CROSS REFERENCE:
Analog Section (Fax supported models only) (P.234)
TAM Interface Circuit (P.47)

12.3.13. Operation Panel Section

Refer to **Test Functions** (P.136).

1. No Key Operation

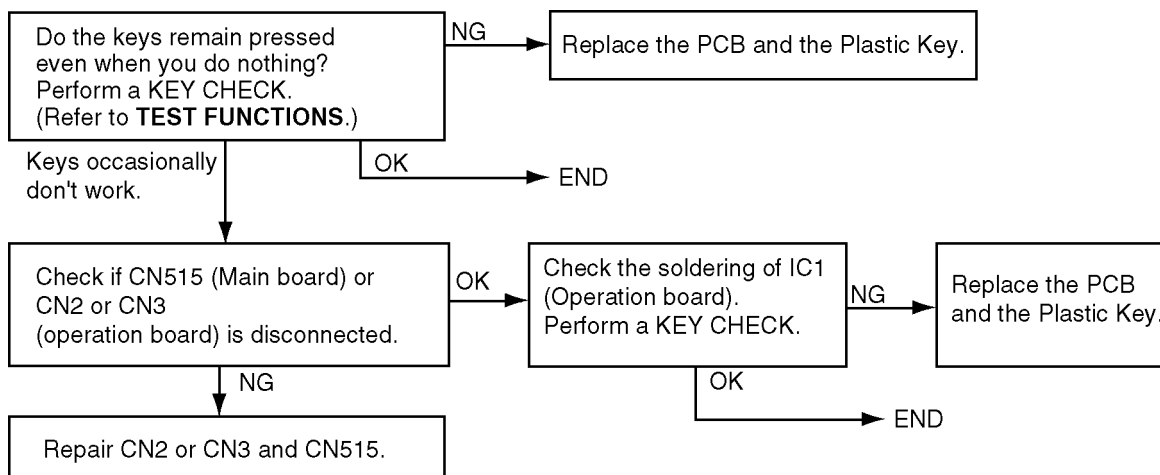

2. No LCD Indication

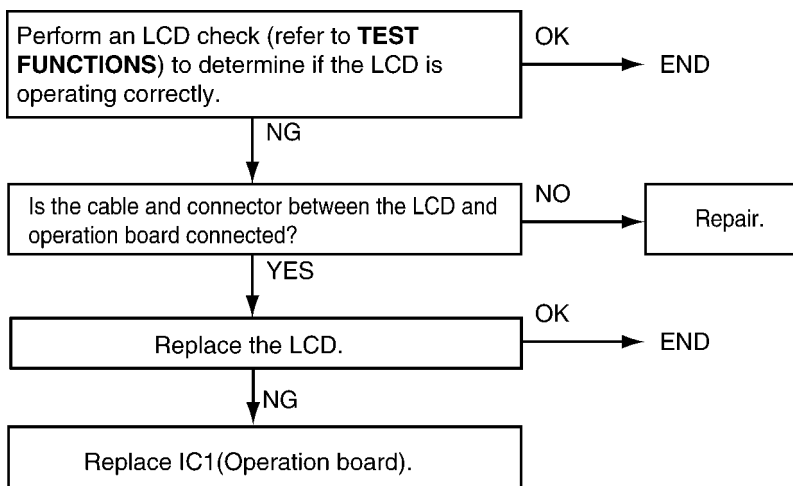

CROSS REFERENCE:

Test Functions (P.136)

12.3.14. Sensor Section

Refer to SENSORS AND SWITCHES for the circuit description.

Perform an SENSOR CHECK to determine if the sensor is operating correctly.

1. Check the Pick up sensor "PAPER JAMMED"

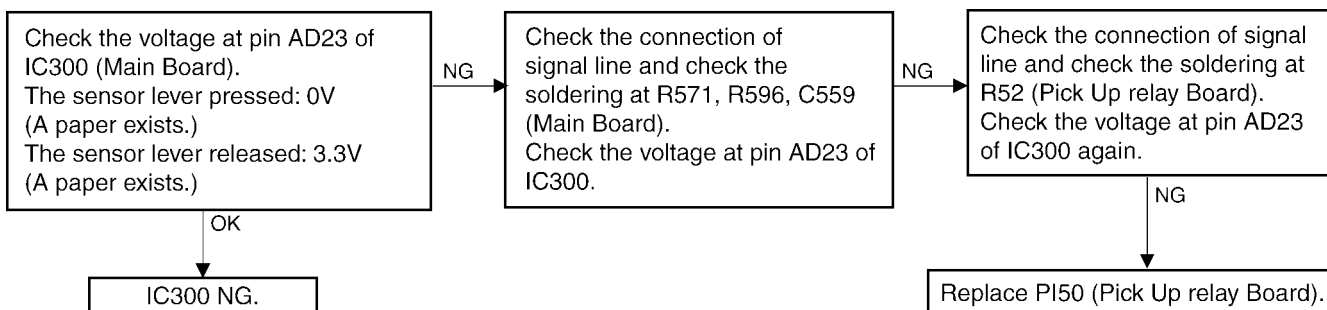

2. Check the Resist sensor..... “PAPER JAMMED”

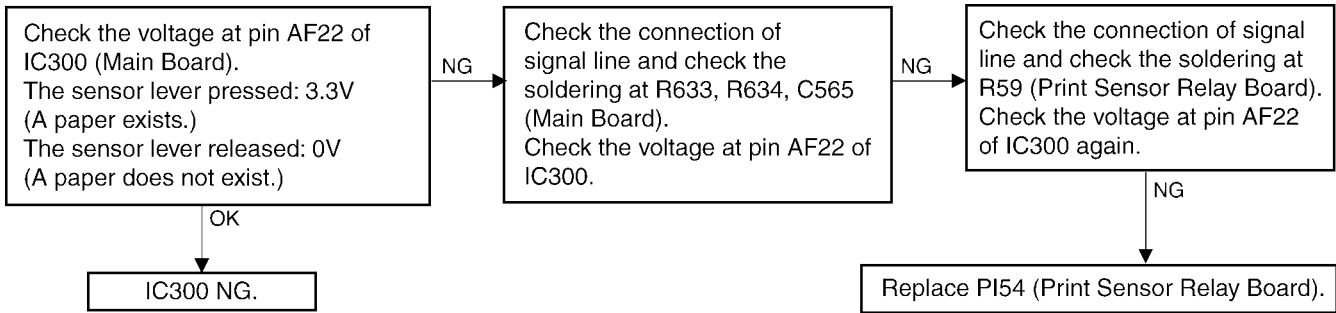

3. Check the PTOP sensor “PAPER JAMMED”

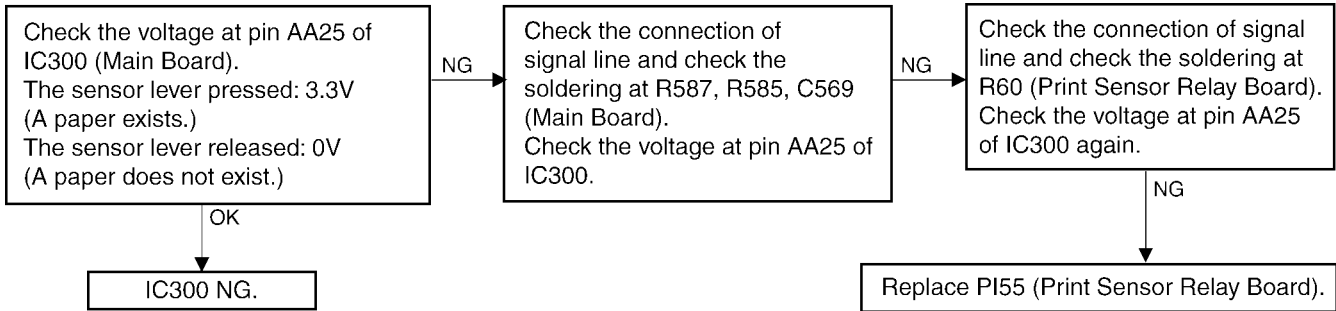

4. Check the ADU sensor “PAPER JAMMED”

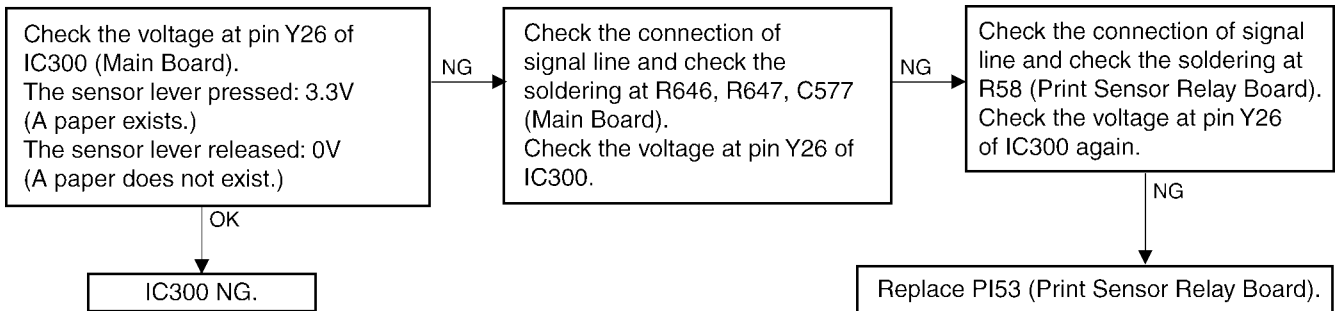

5. Check the Exit sensor “PAPER JAMMED”

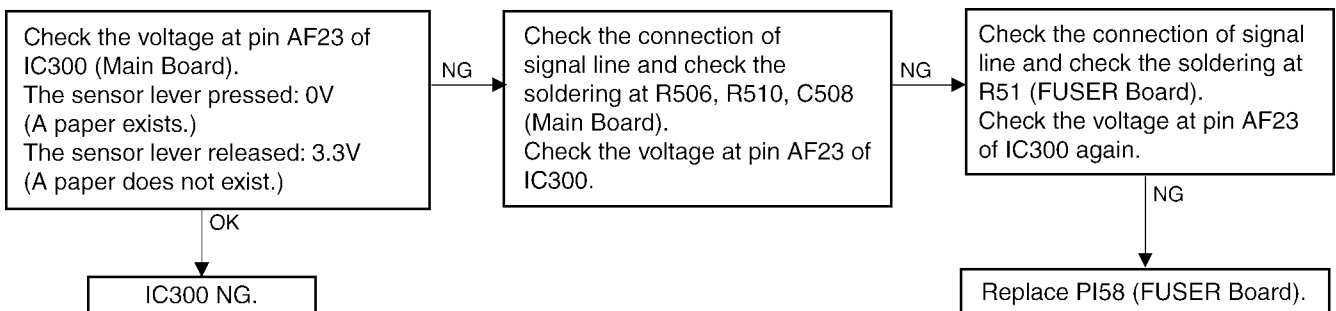

6. Check the Document sensor “REMOVE DOCUMENT”

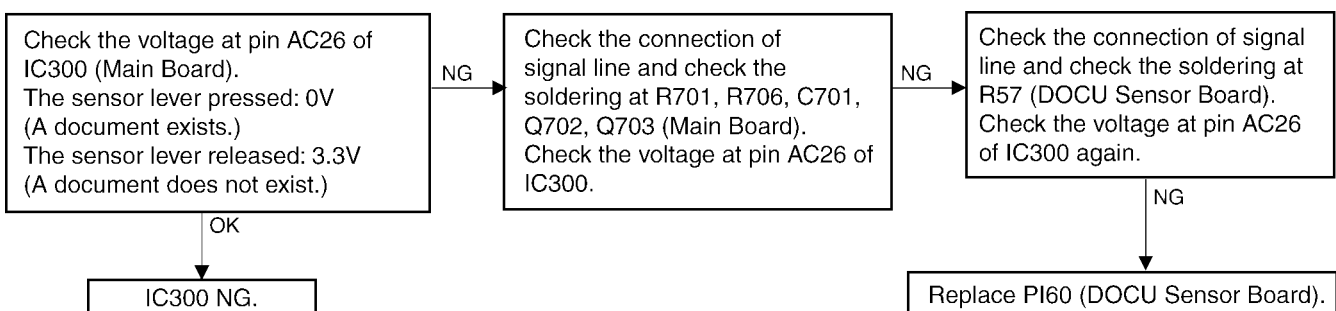

7. Check the Read position sensor “REMOVE DOCUMENT”

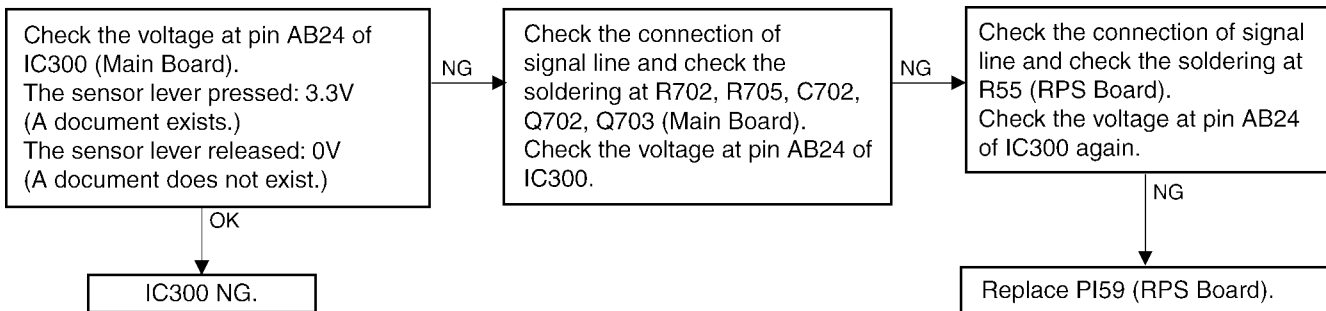

8. Check the RADF JAM sensor “REMOVE DOCUMENT”

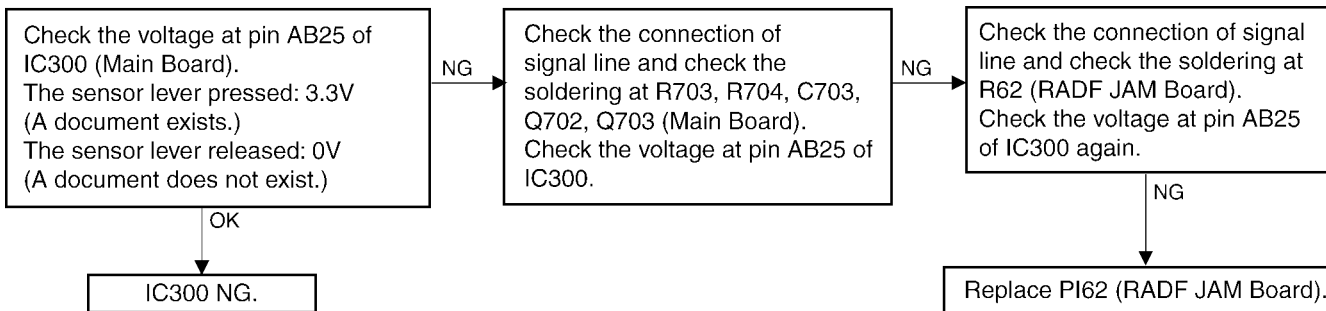

9. Check the MPT sensor “PAPER JAMMED”

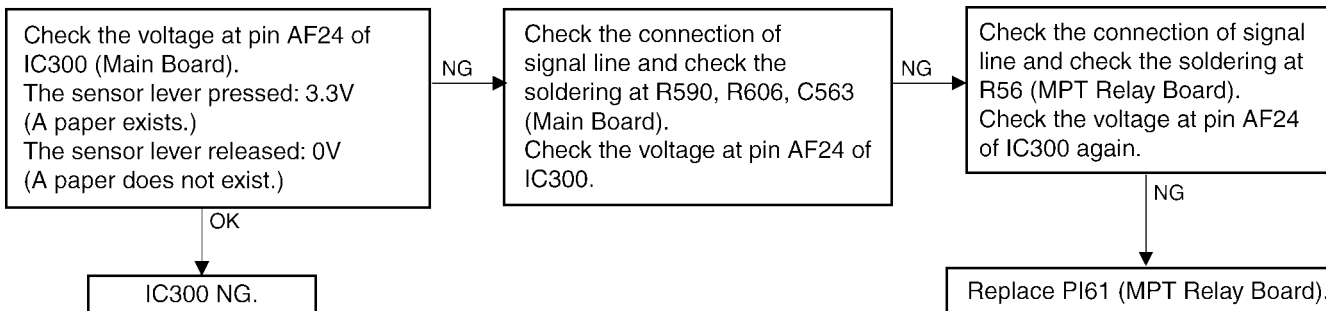

10. Check the PAPER sensor “OUT OF PAPER”

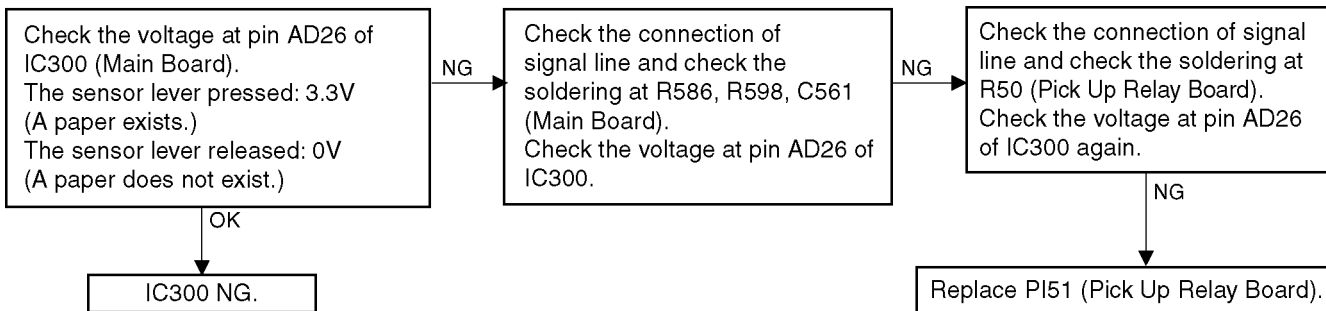

11. Check the CSopen sensor “CHECK INSTALL INPUT TRAY#1”

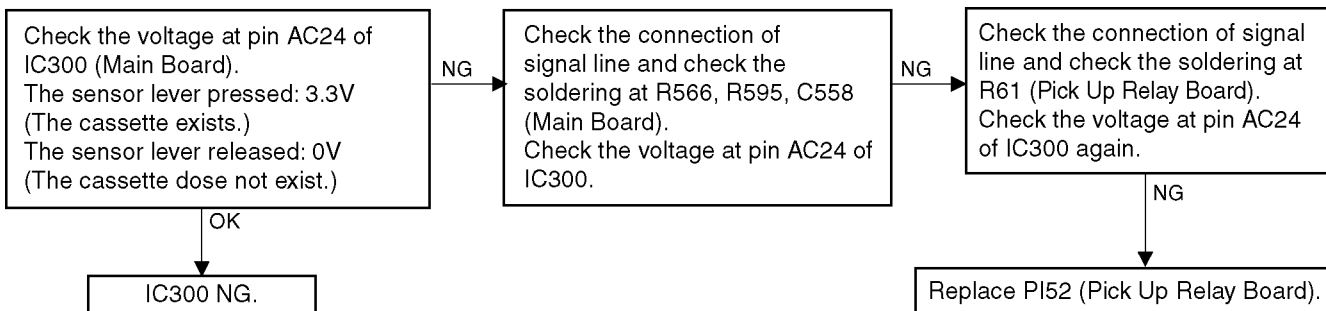

12. Check the Rear door sensor “OPEN REAR COVER”

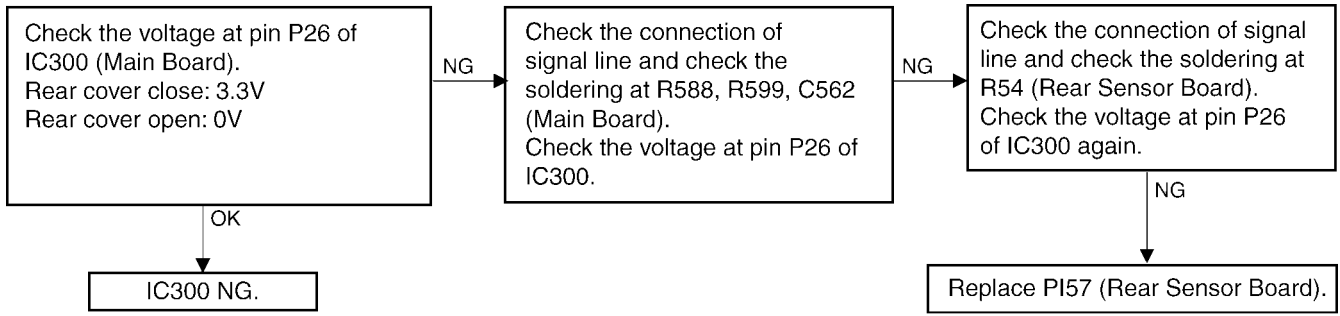

13. Check the Interlock switch..... “FRONT COVER OPEN”

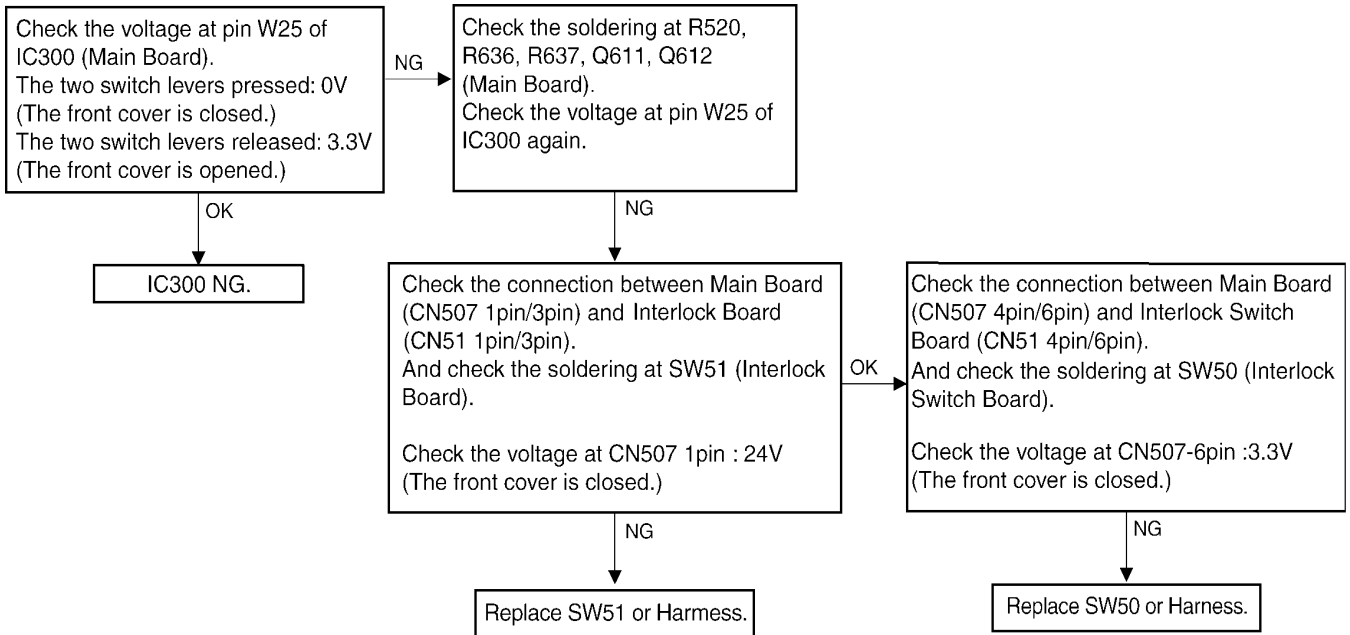

14. Check the toner sensor..... “TONER LOW”, “TONER EMPTY”, “CHANGE CARTRIDGE”

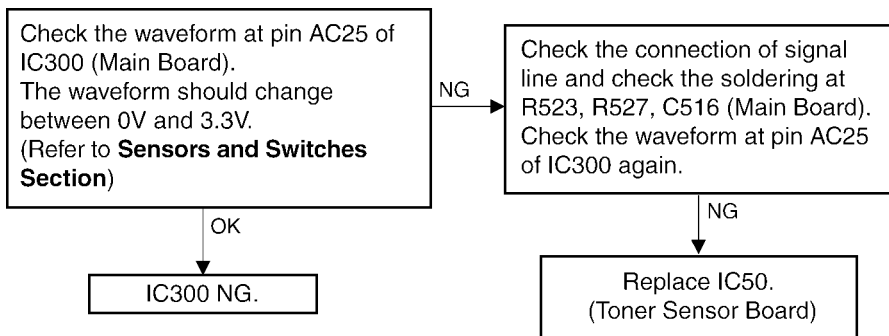

Toner Detection Flow

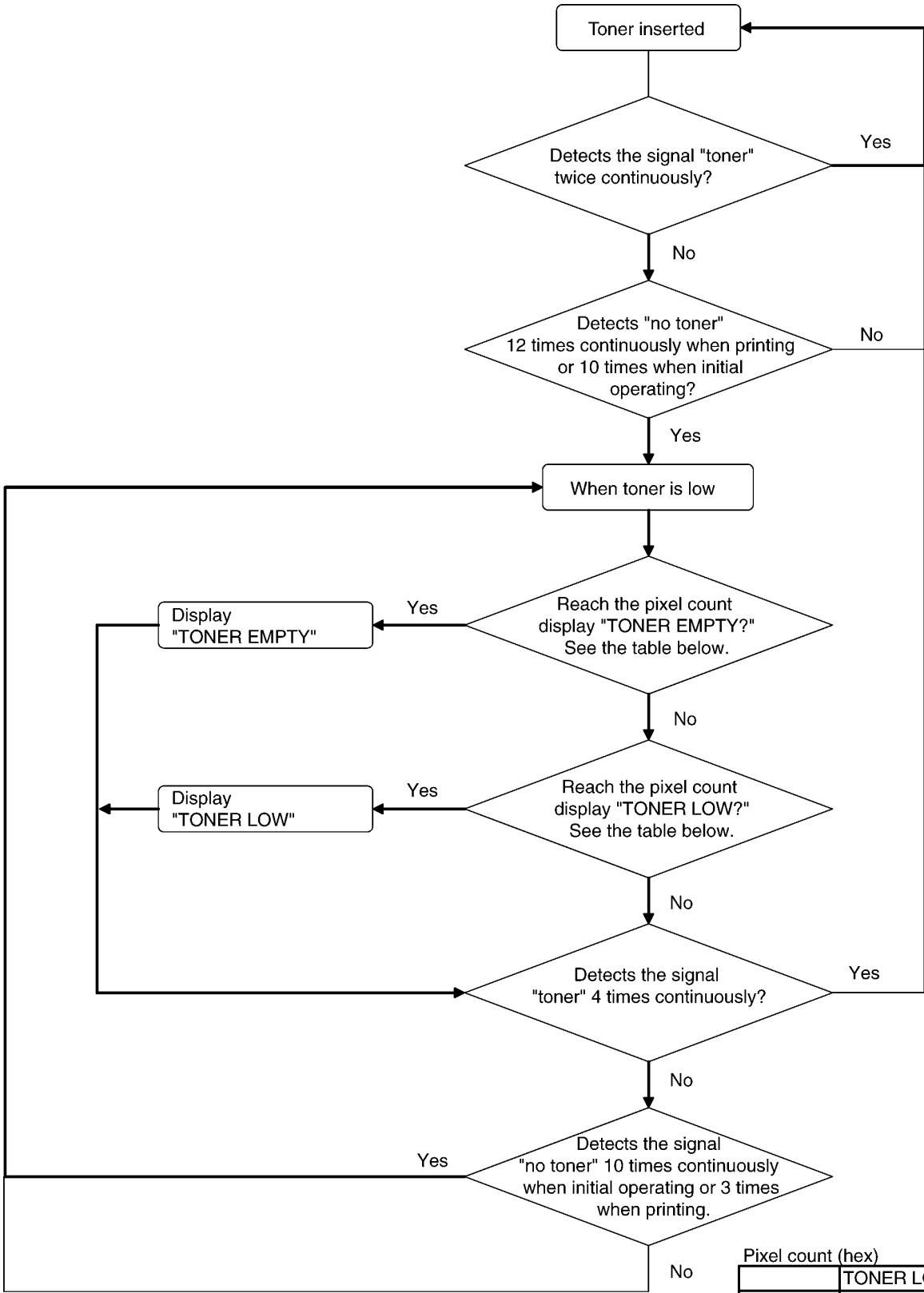

Pixel count (hex)

	TONER LOW	TONER EMPTY
1.0K	3C1E358E	Warning + 140A11DA
1.5K	5FBE554A	
2.0K	5FBE554A	
3.0K	3C1E358E	
6.0K	34D4BAB3	
8.0K	2EC229A7	

15. Drum Life Detection Flow

Drum Life (D/L) Detection Flowchart

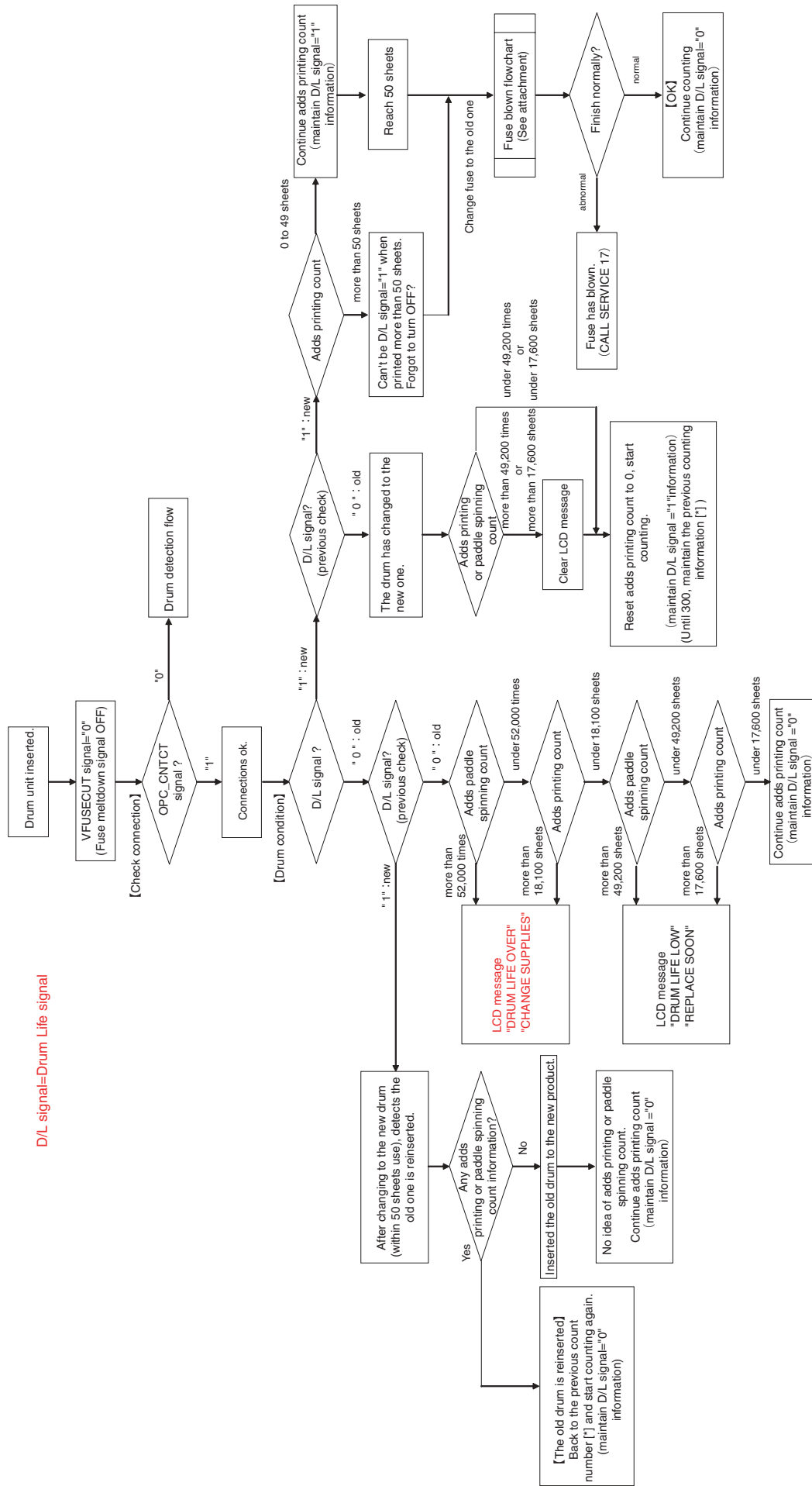

16. Check the document sensor

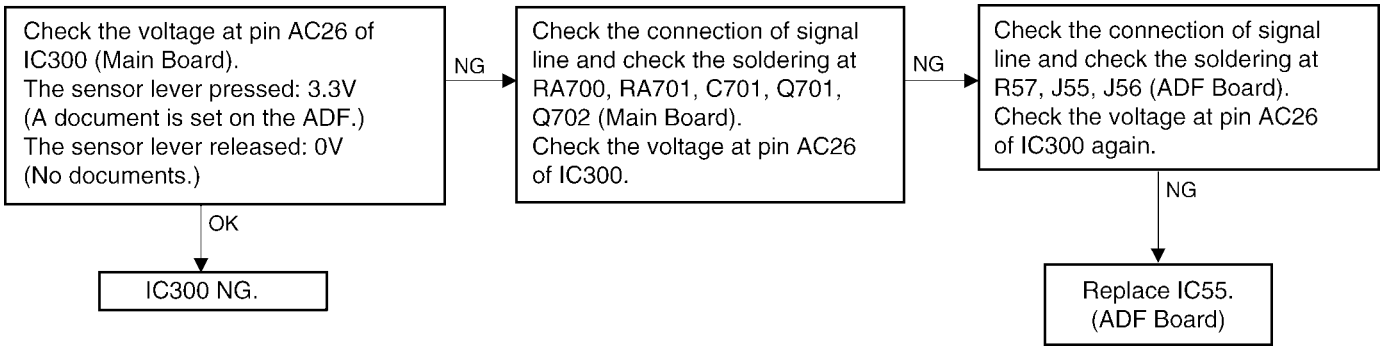

17. Check the read position sensor..... “CHECK DOCUMENT”

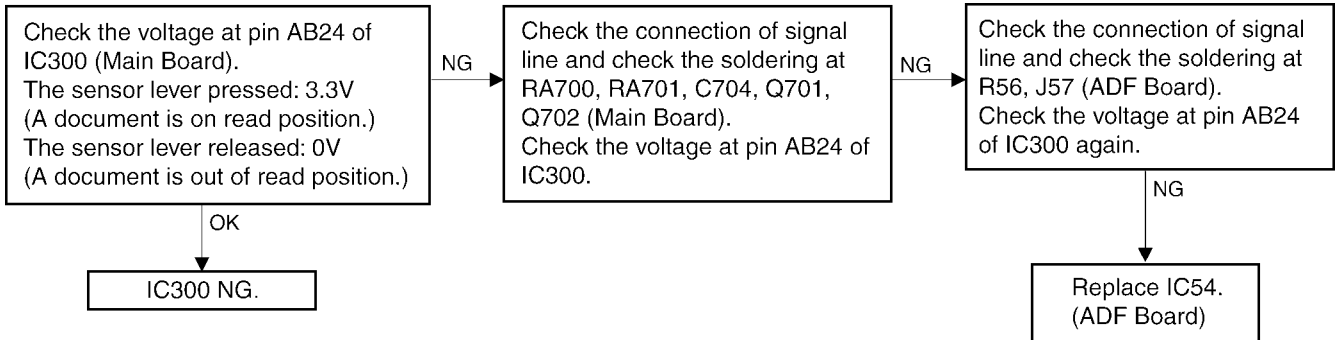

12.3.15. Motor Section

12.3.15.1. Main Motor

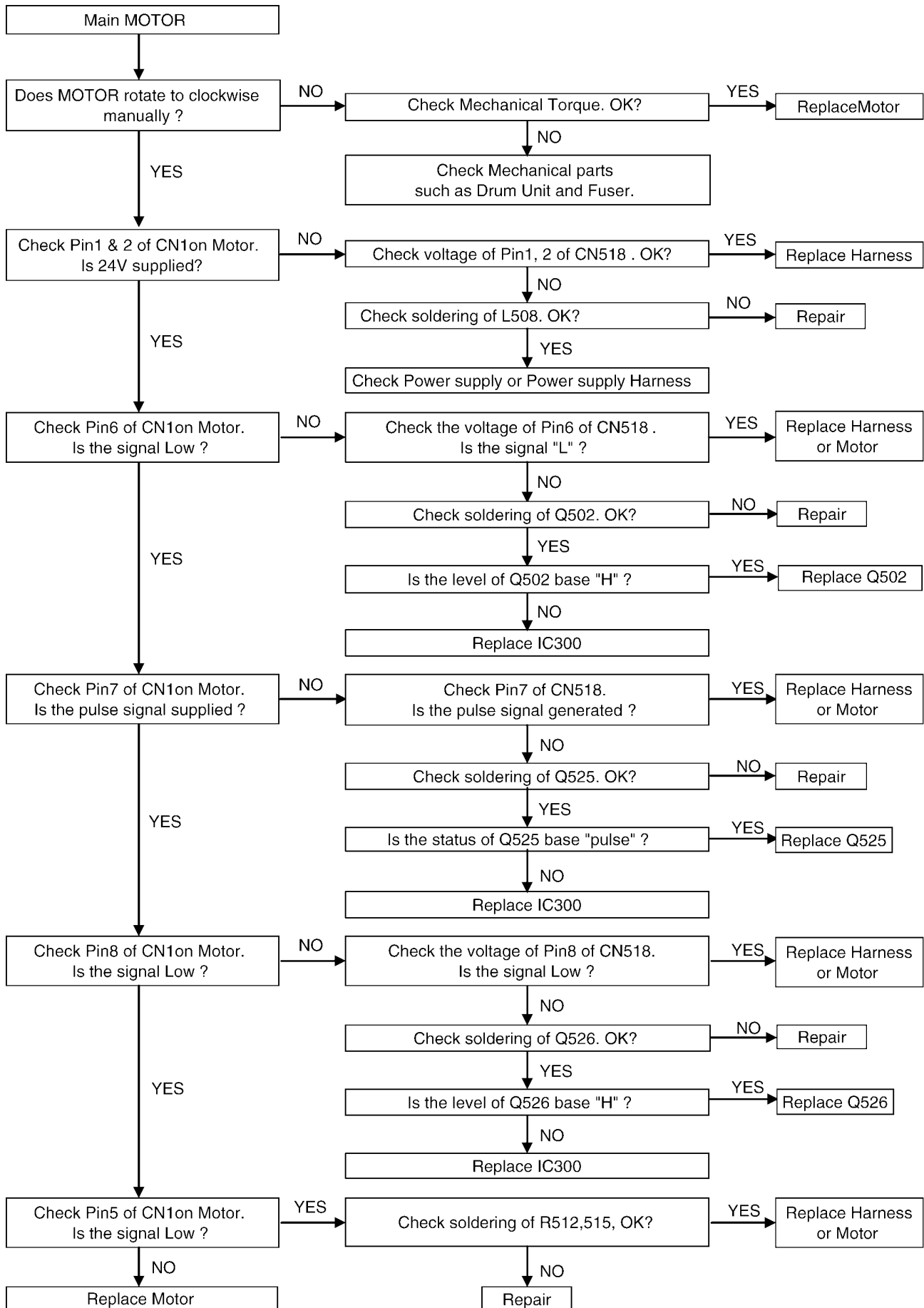

12.3.15.2. FB Motor

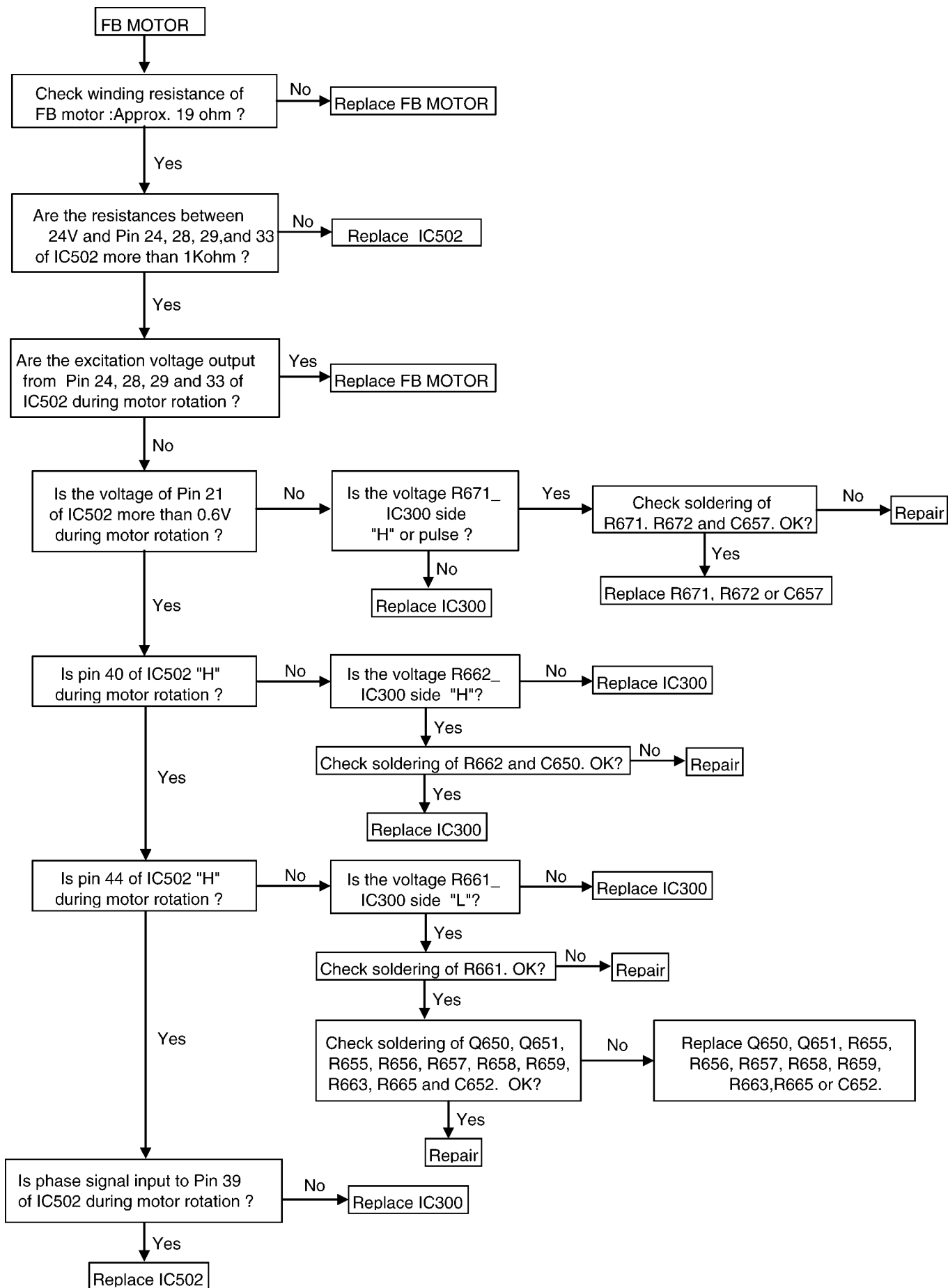

12.3.15.3. ADF MOTOR

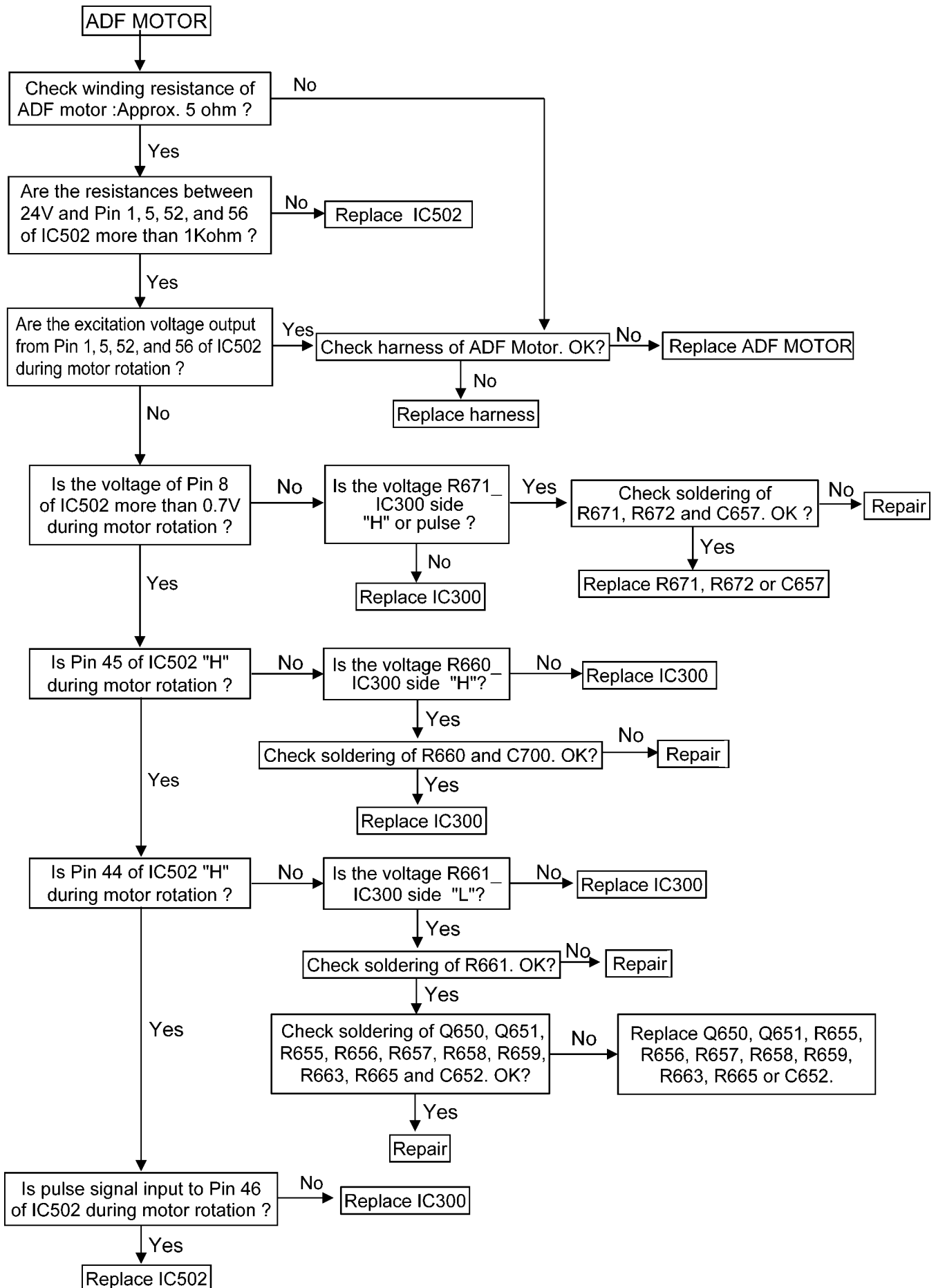

12.3.16. LSU Section

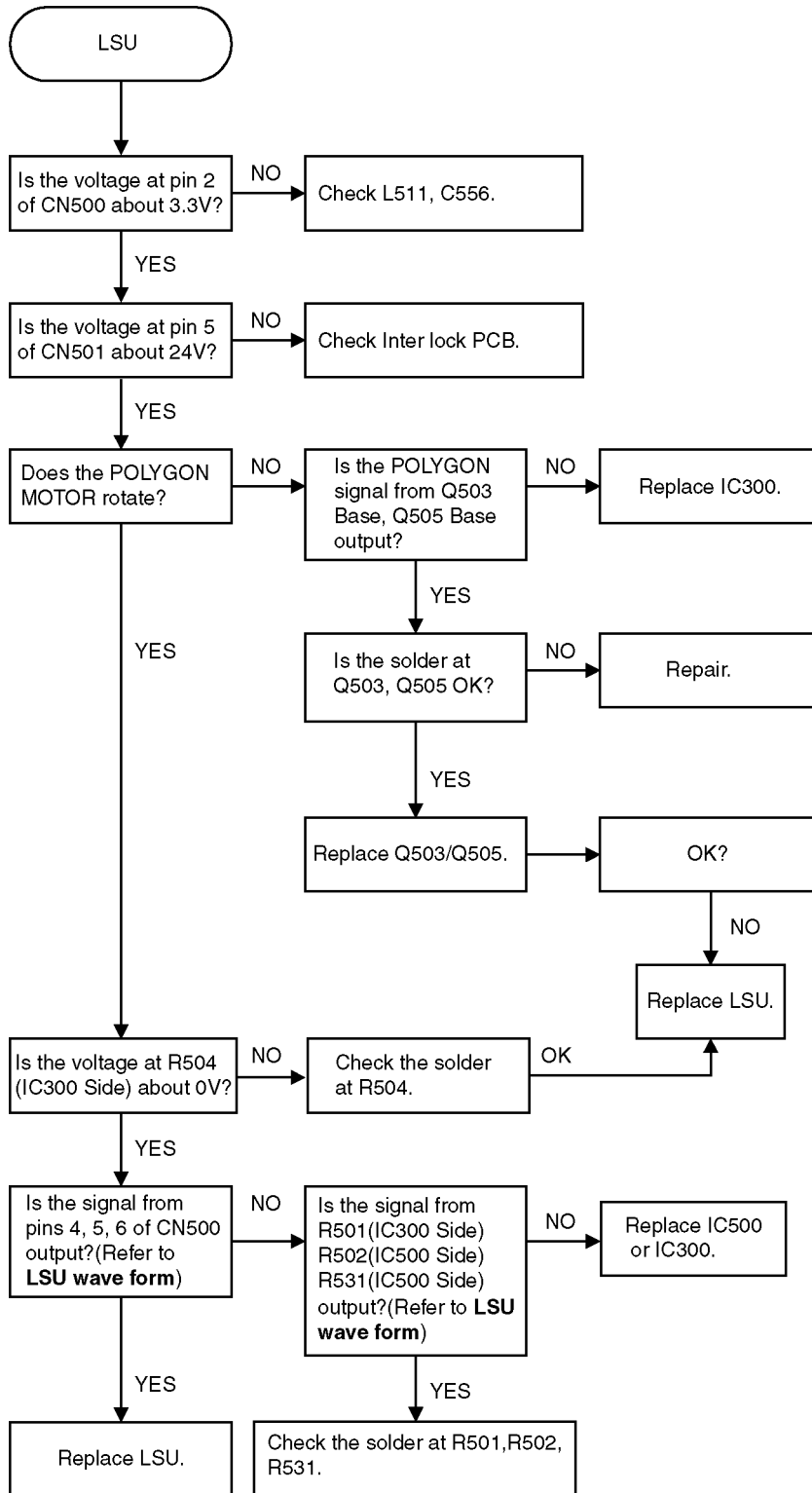

CROSS REFERENCE:

LSU (Laser Scanning Unit) Section (P.75)

12.3.17. CIS Control Section

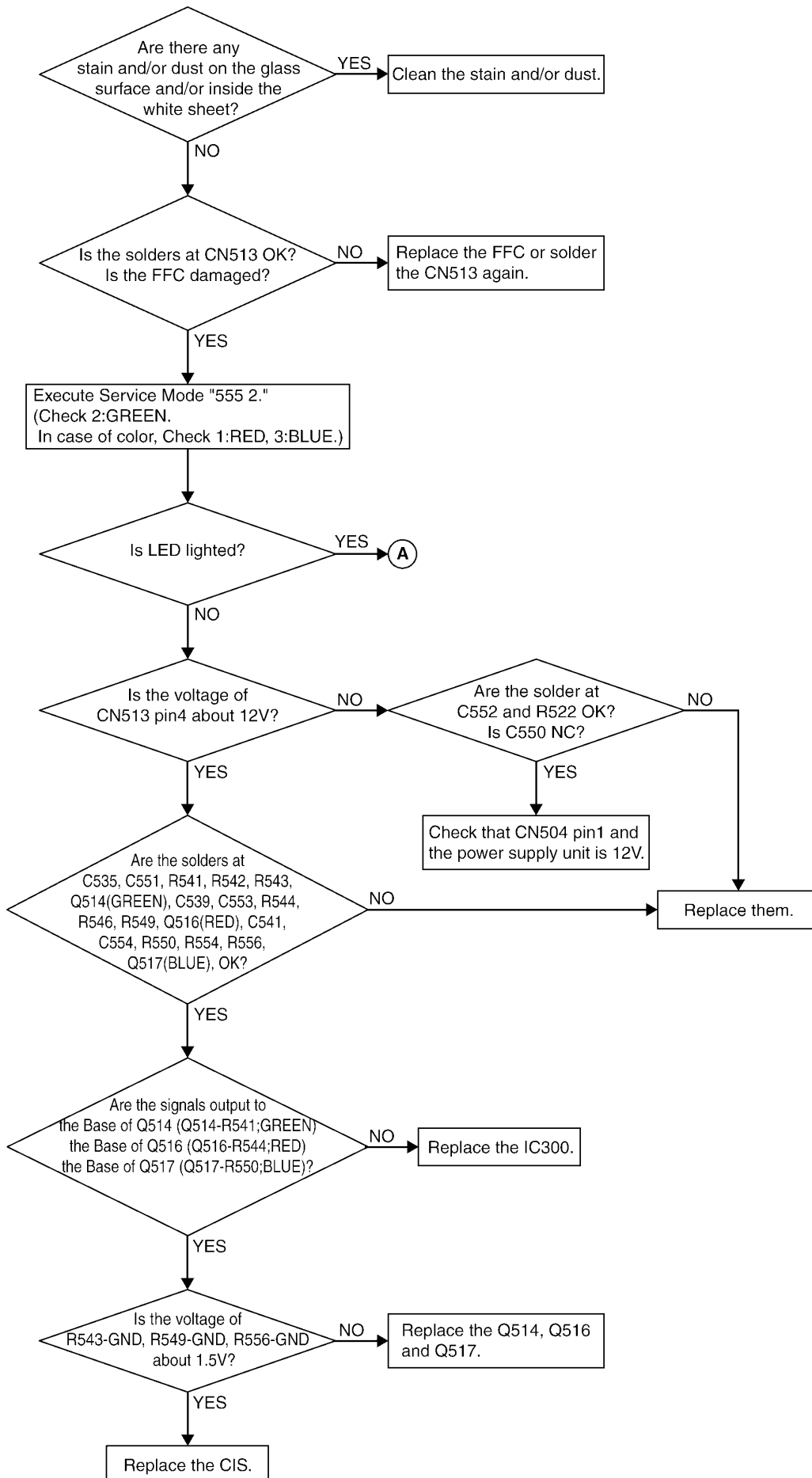

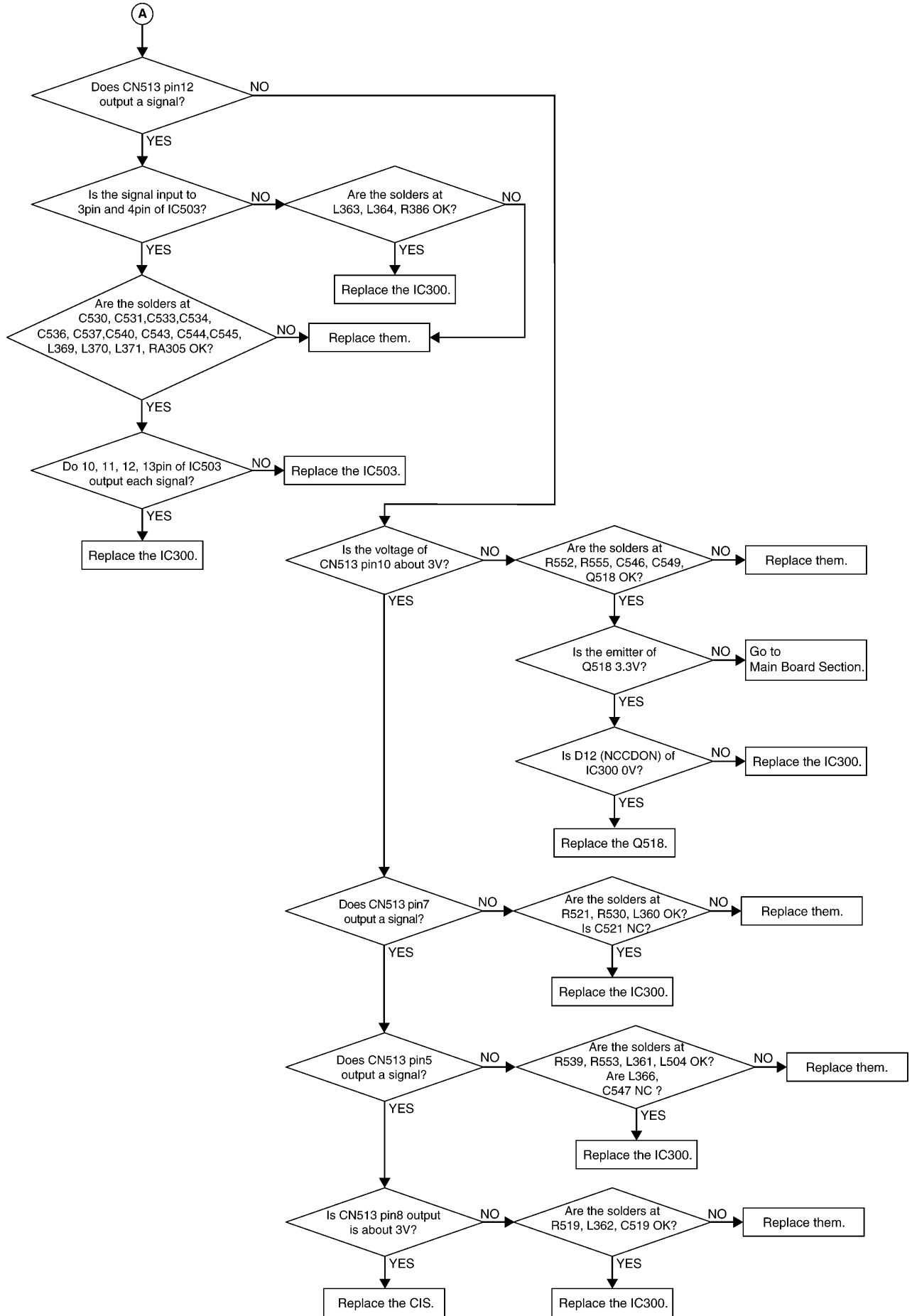

CROSS REFERENCE:
Test Functions (P.136)
Main Board Section(P.264)

12.3.18. High Voltage Value Check Point

Measurement Procedure

1. Turn off the power supply.
2. Remove the right cover of the main unit and then remove the protection cover of high voltage power supply. See Figure 1.
3. See Figure 2 for the high voltage value check point.
4. Set the drum and developing unit in the main unit. Close the front cover and then turn the power supply on. Be careful not to touch the main board as it produces high voltage.
5. Let the tip of the high voltage probe touch the value point. At this time, be careful not to touch other parts of the main unit.
6. Remove the recording paper cassette. And then turn the service mode on and input 556.
7. Press SET. The main unit starts producing high voltage.
8. Press STOP when high voltage value check is finished. The main unit stops operating and producing high voltage.
9. Repeat step 5 to 8 to check the value of all points.
10. Put the right cover on when the value check is finished.

Each terminal's output voltage

No.	BIAS Name	Rated Output	Rated Output Range
1	CHG (Charge)	200 μ A	200 \pm 15 μ A Output voltage about 4.1~4.6KV
2	GRID(grid)	475V	475 \pm 10V
3	DEV (Developing)	230V	200~300V
4	TRA (Transfer)	785V	785 \pm 100V

* FLUKE85(MULTIMETER)+HIOKI(HV PROBE 9014)or the equivalent should be used as the high voltage measuring instrument.(Fig.6)

* As for measuring TRA, start measuring within 4 seconds after pressing the SET button. The output value will be changed in 4 seconds.

Fig. 1

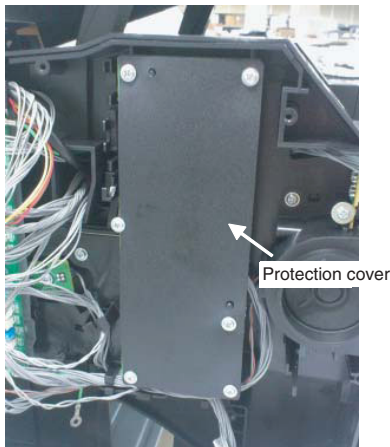

Fig. 2

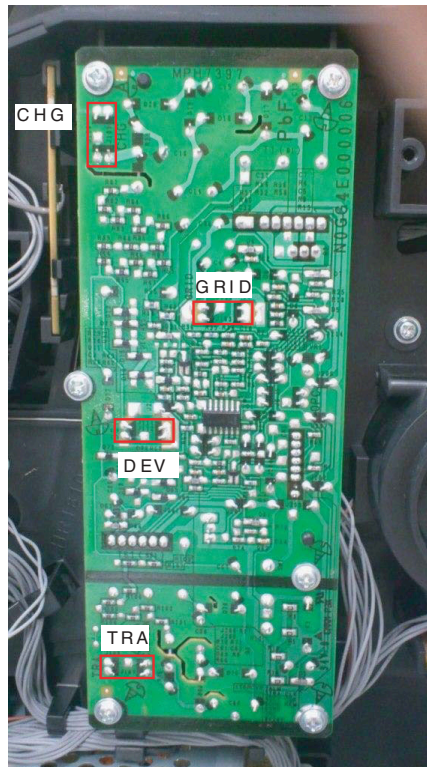
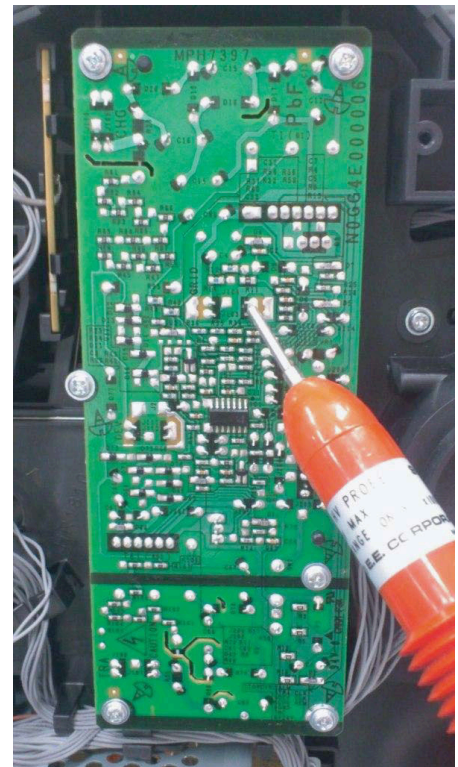
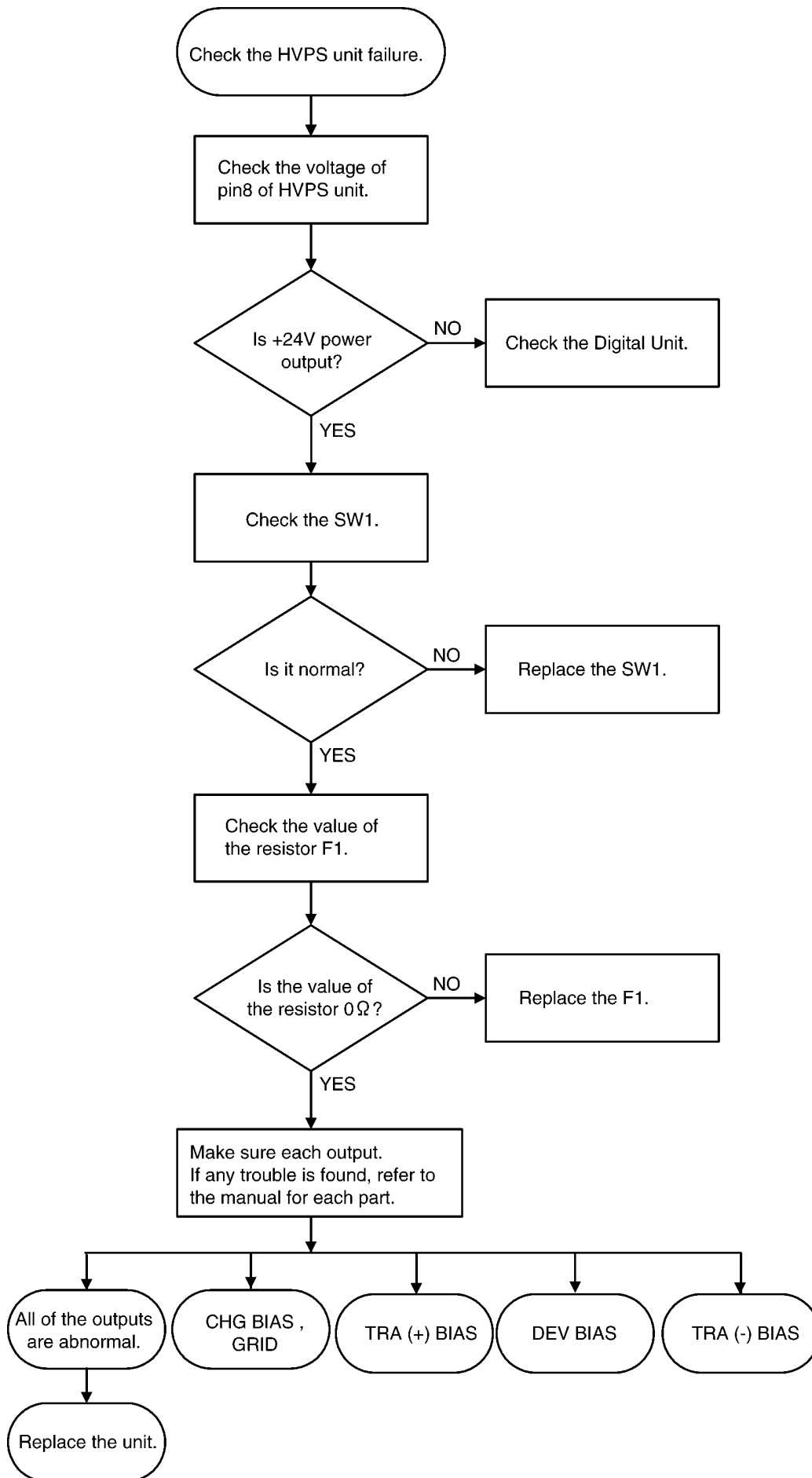

Fig. 3



12.3.19. High Voltage Section

1. Main



2. CHG, GRID

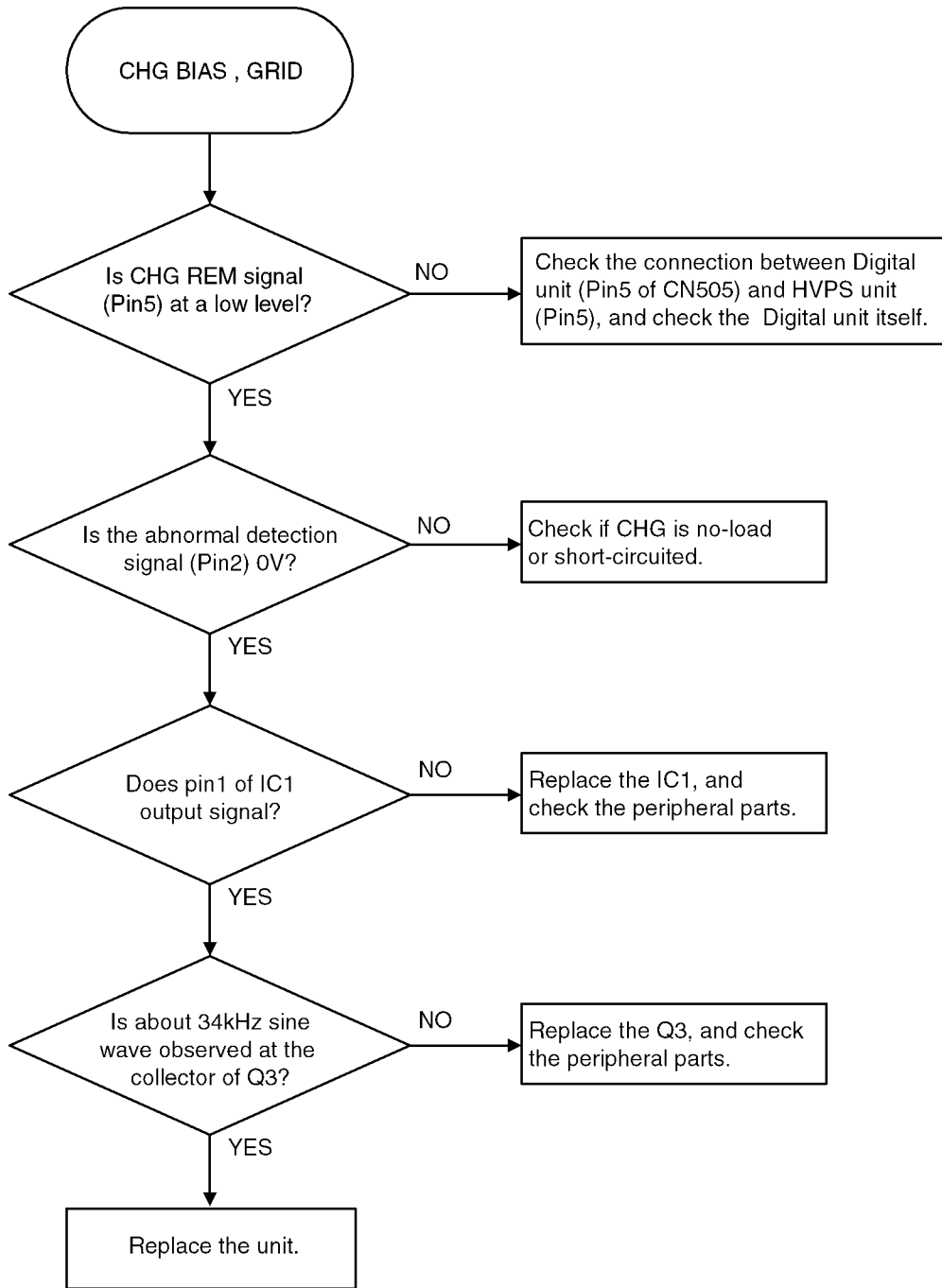

3. TRA (+)

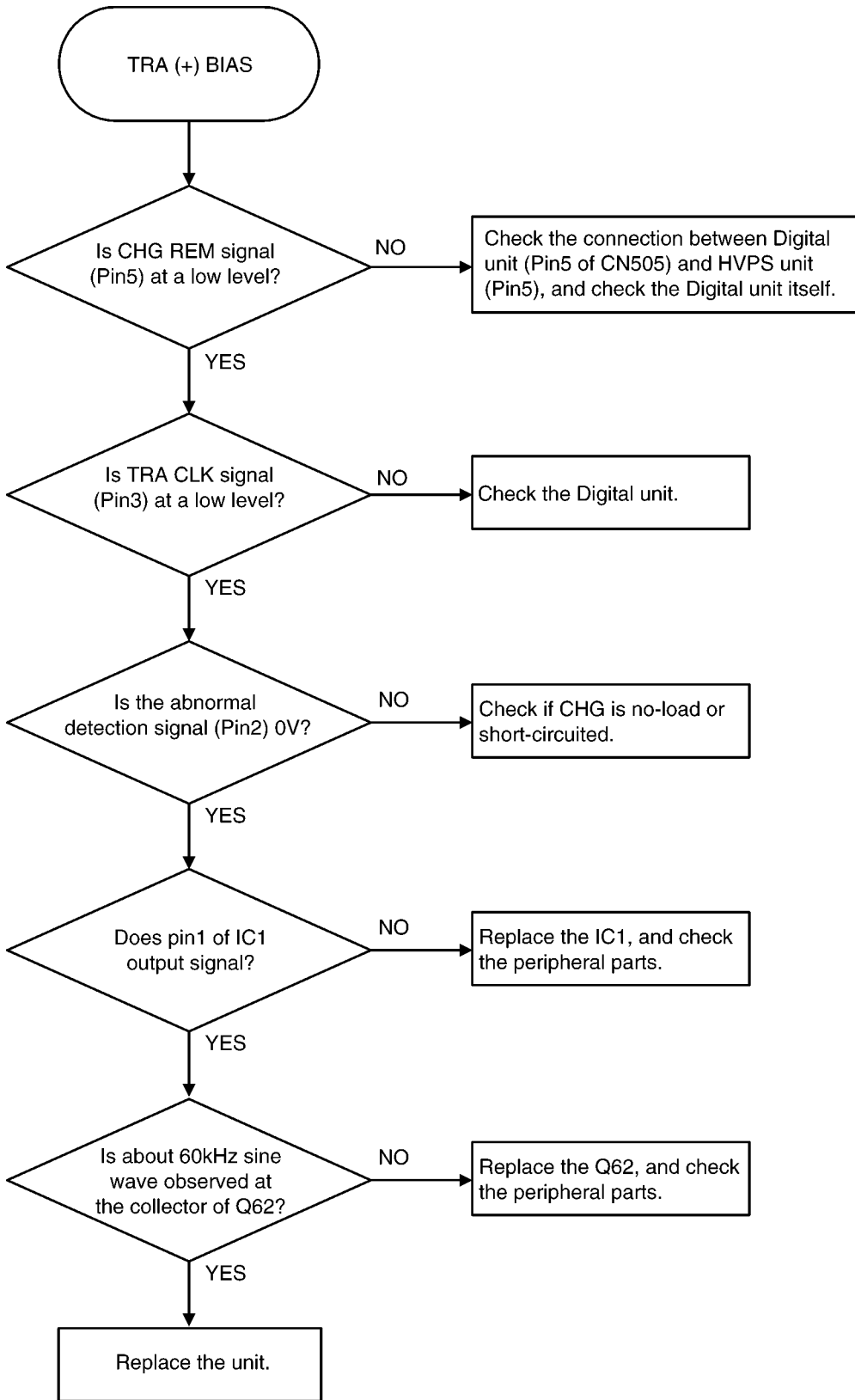

3. DEV DC

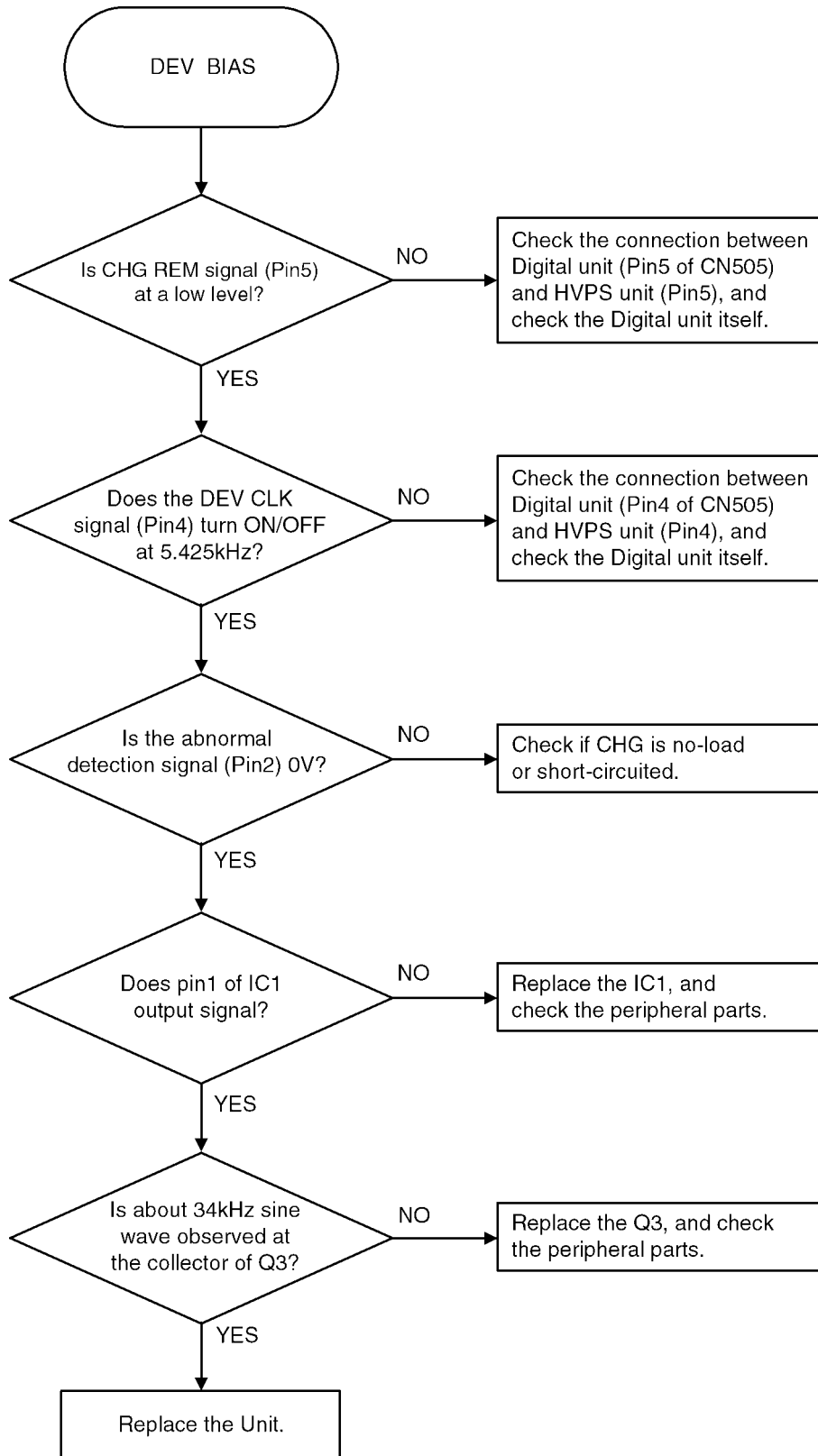

TRA (-)

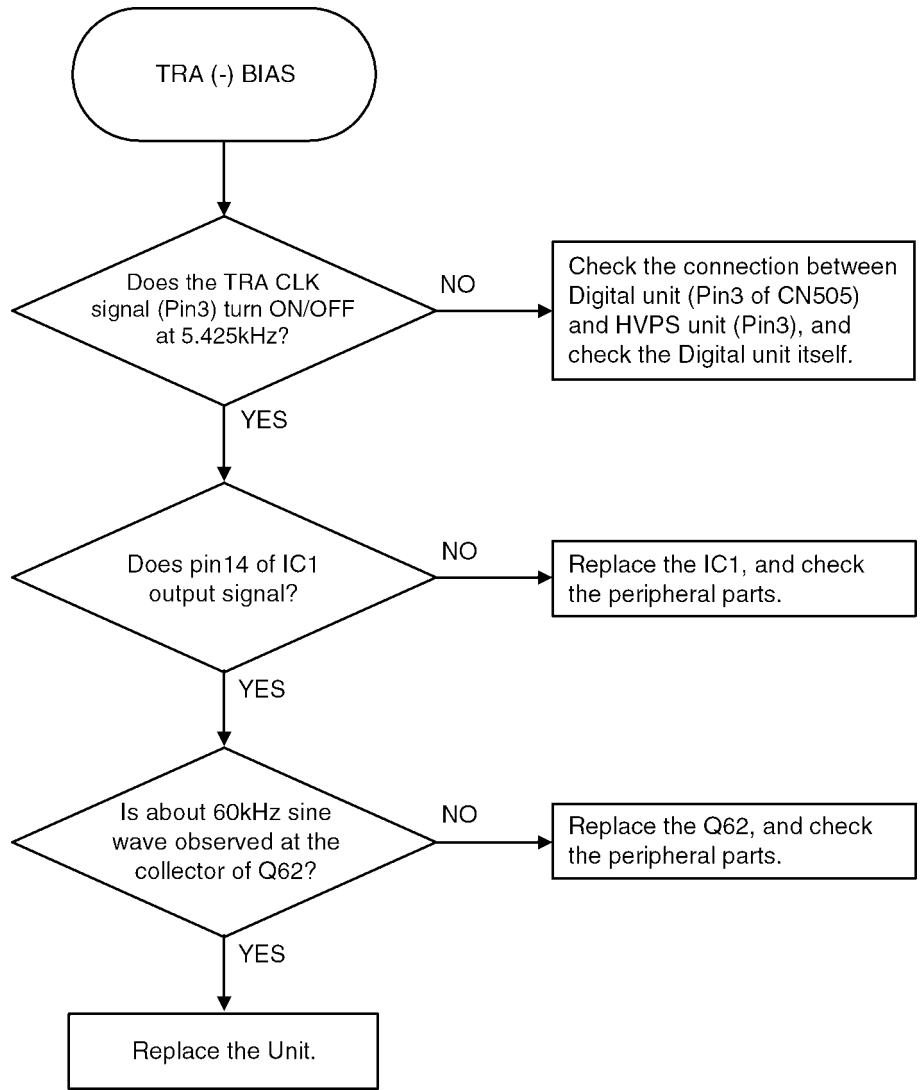

12.3.20. USB Section

Troubleshooting

Connection with the PC

1. Confirmation of the PC settings

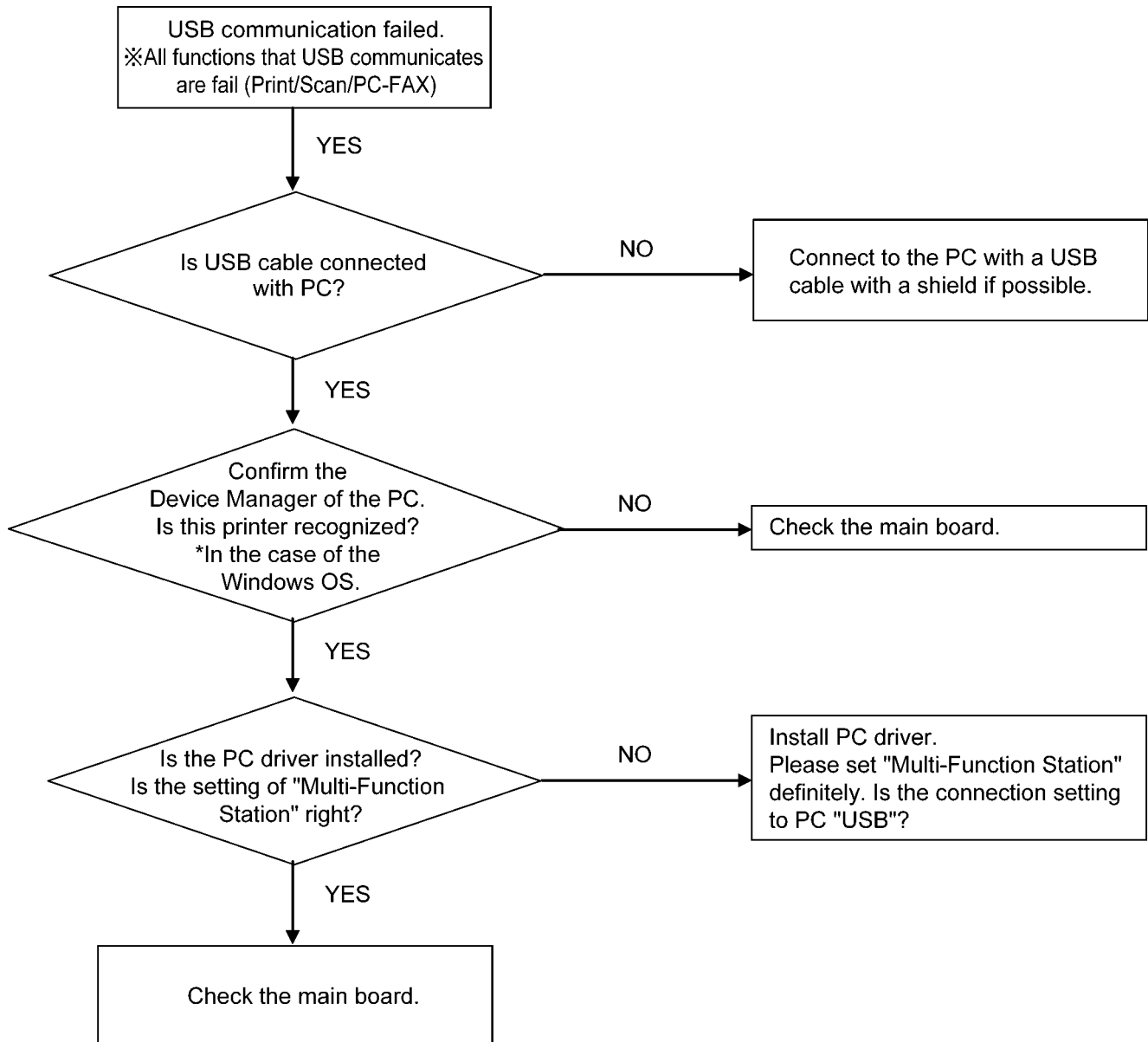

2. Confirmation of the main unit

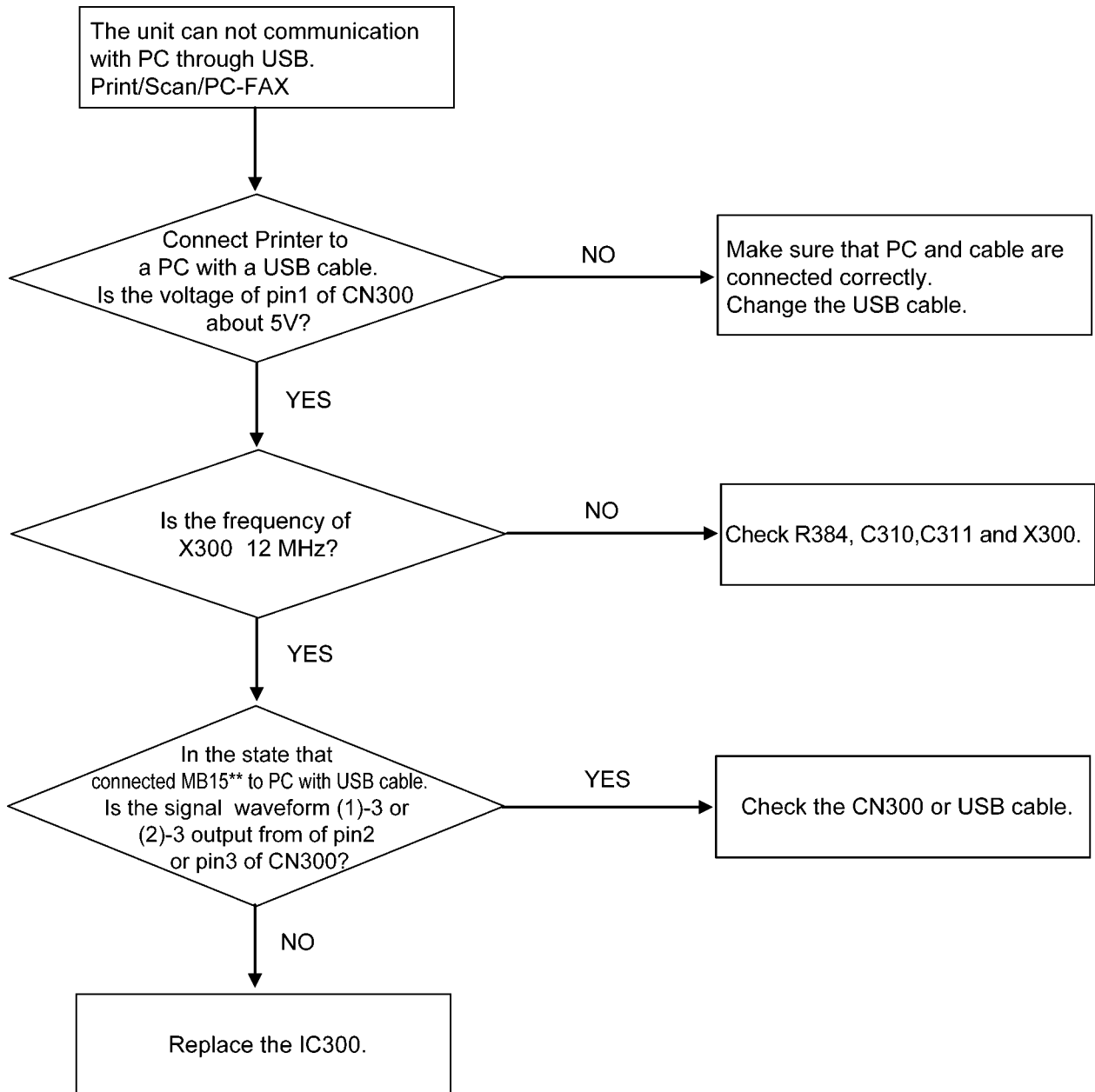

Connection with the USB memory

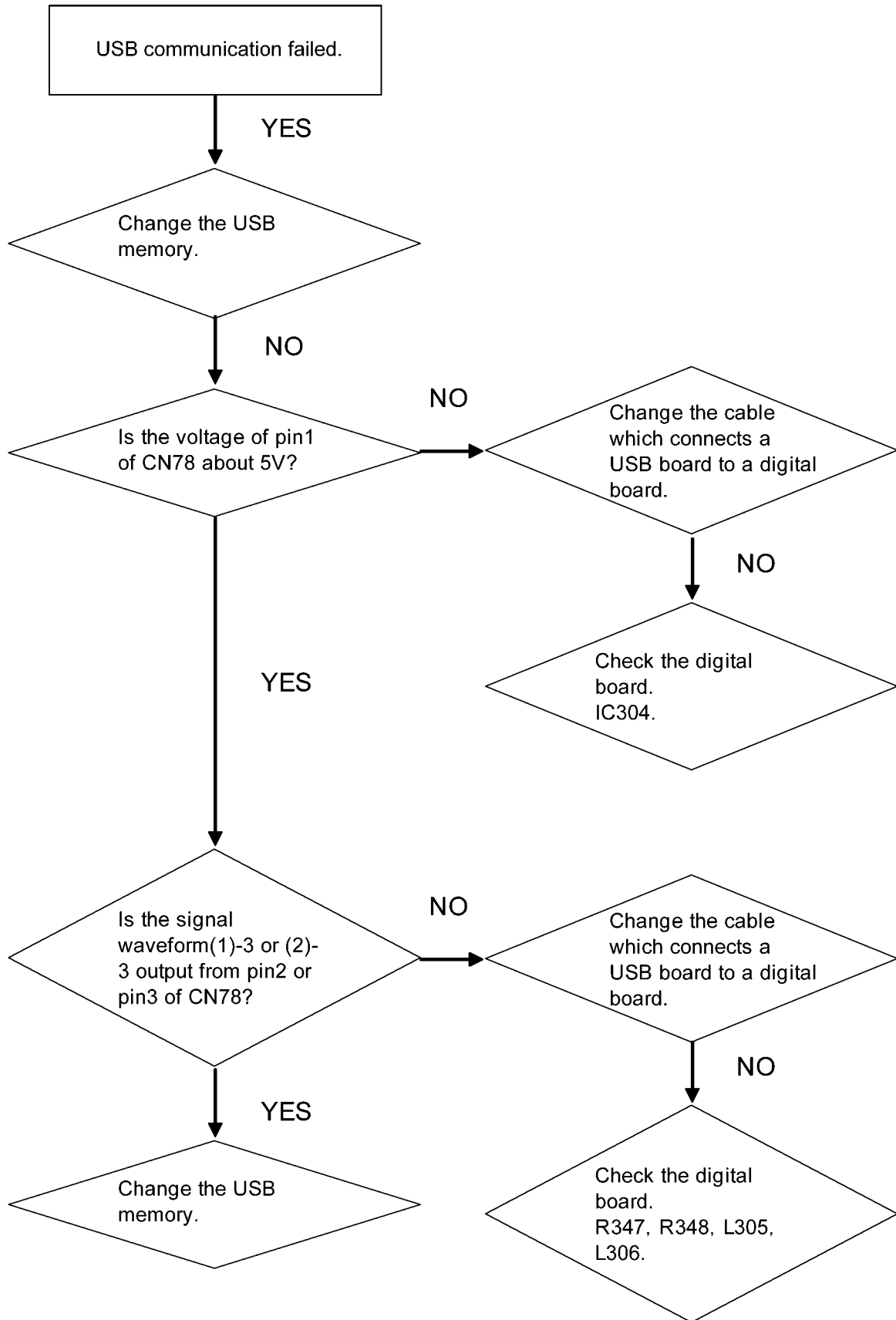

USB (Universal Serial Bus) block

Description

This is a USB block for data communication with PC.

Two signal lines (D+/D-) are differential signals which work in reverse phase.

VBUS: CN300/CN301 1pin

D-: CN300/CN301 2pin

D+: CN300/CN301 3pin

GND: CN300/CN301 4pin

Circuit Diagram

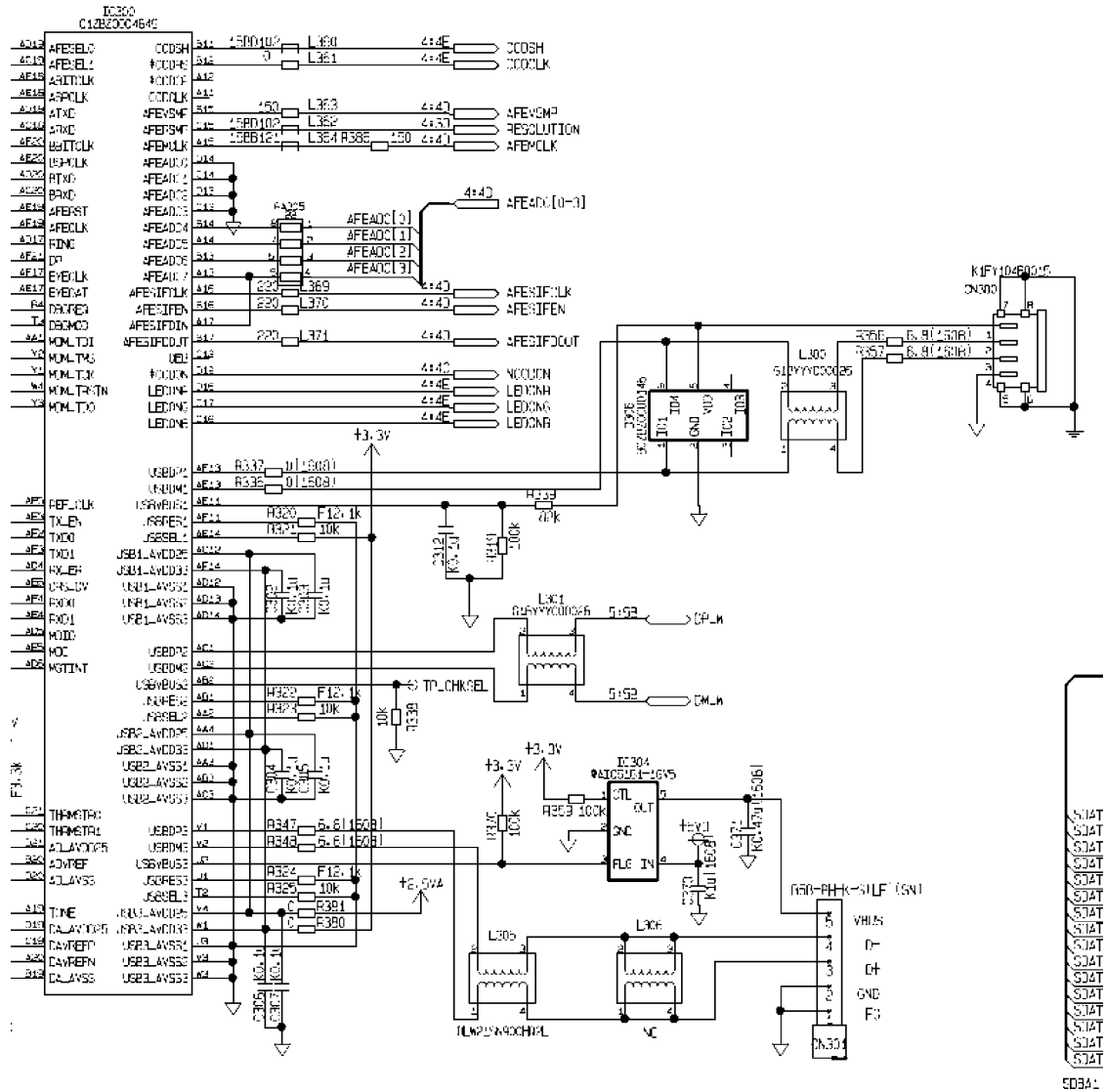

Sequence of normal operation

Connection with the PC

When USB cable from PC is connected to CN300, VBUS voltage goes up to 5V, and IC300 recognize the connection with PC.

Then D+ becomes about 3V: waveform (1)-1

The D+ becomes 0V, then communication between IC300 and PC is started: waveform (2)-1

When a few seconds elapsed after USB cable was inserted into CN300, the unit enters stand-by mode.

When PC is at Hi-Speed, waveforms are (1)-1 ~ (1)-4.

When PC is at Full Speed, waveforms are (2)-1 ~ (2)-4.

Connection with the USB memory

When connected MB2500 and USB memory, through 1pin of CN77, 5V is supplied to the USB memory.

Then D+ becomes about 3V: waveform (1)-1.

The D+ becomes 0V, then communication between IC300 and USB memory is started: waveform(2)1.

When USB memory is Hi-Speed, waveform are (1) ~ (1)-4.

When USB memory is Full-Speed, waveform are (2) ~ (2)-4.

Waveform of normal operation

(1) The condition during communication establishment between PC and Main unit at Hi-Speed.

Waveform (1)-1 at Hi-Speed

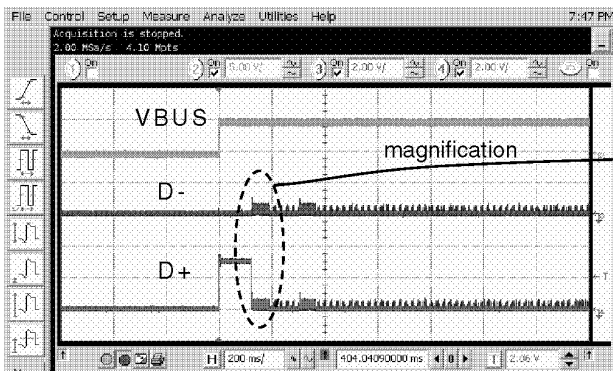

Waveform (1)-2 at Hi-Speed

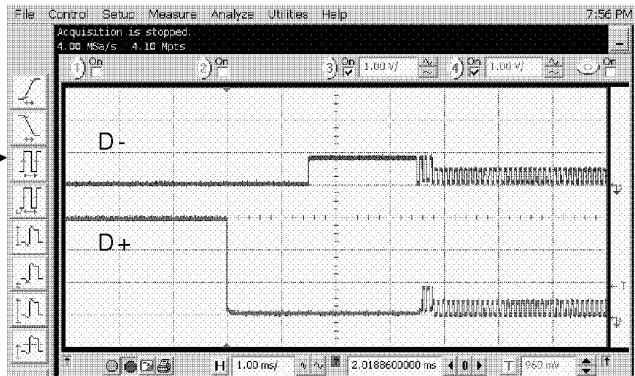

Waveform (1)-3 at Hi-Speed

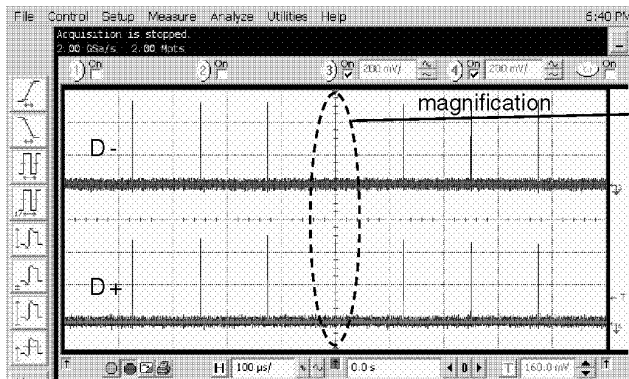

Waveform (1)-4 at Hi-Speed

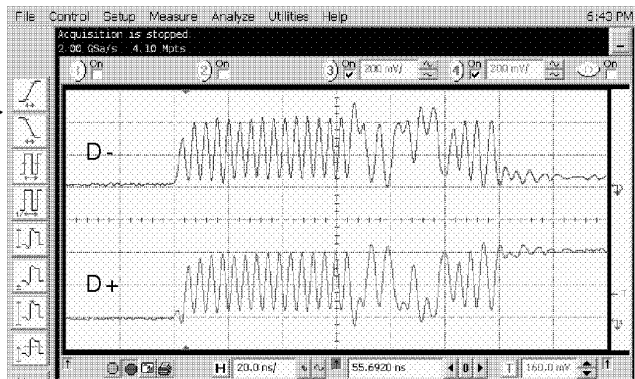

(2) The condition during communication establishment between PC and Main unit at Full Speed.

Waveform (2)-1 at Full Speed

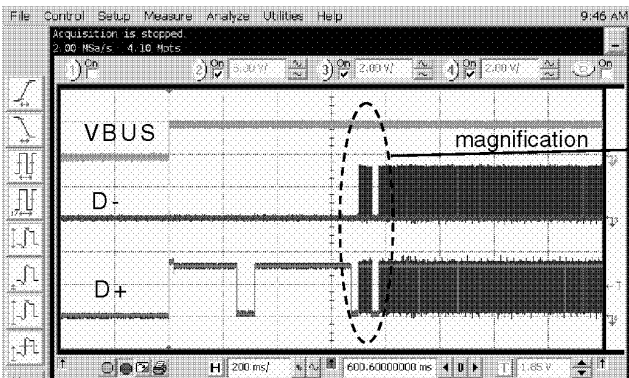

Waveform (2)-2 at Full Speed

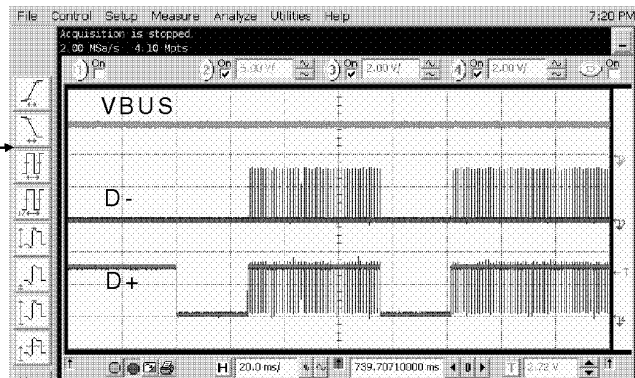

Waveform (2)-3 at Full Speed

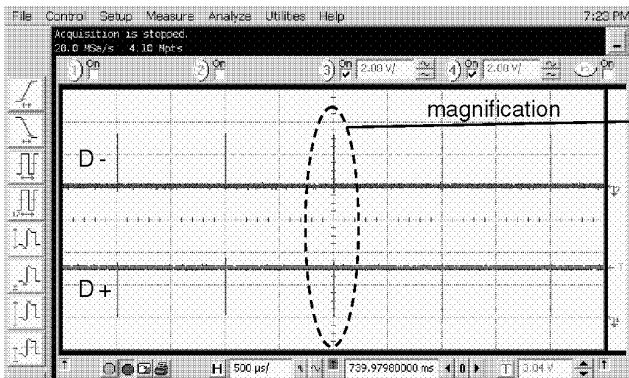

Waveform (2)-4 at Full Speed

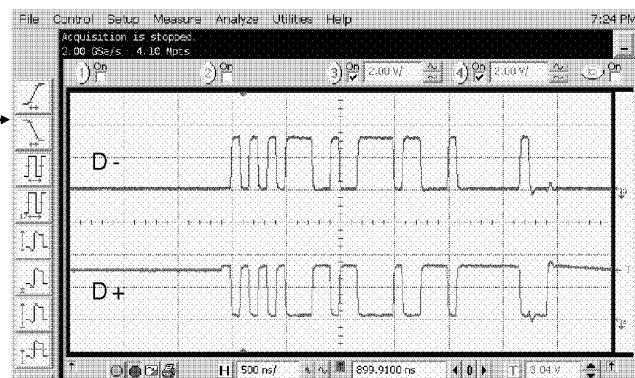

12.3.21. LAN Section

LAN Block Diagram

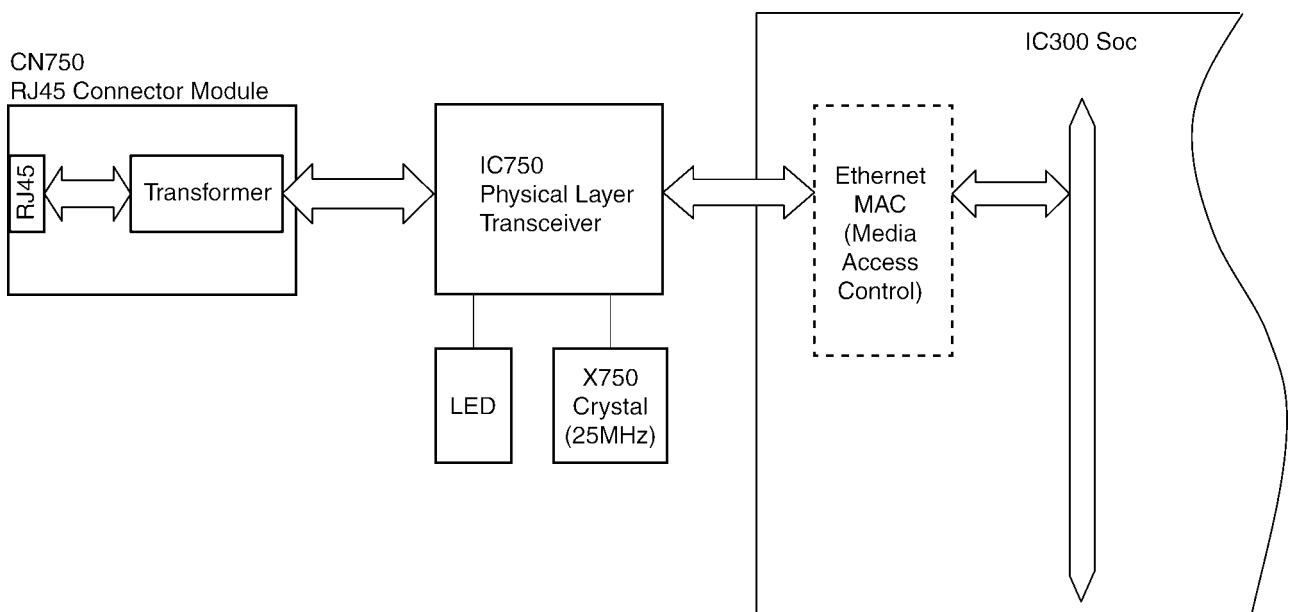
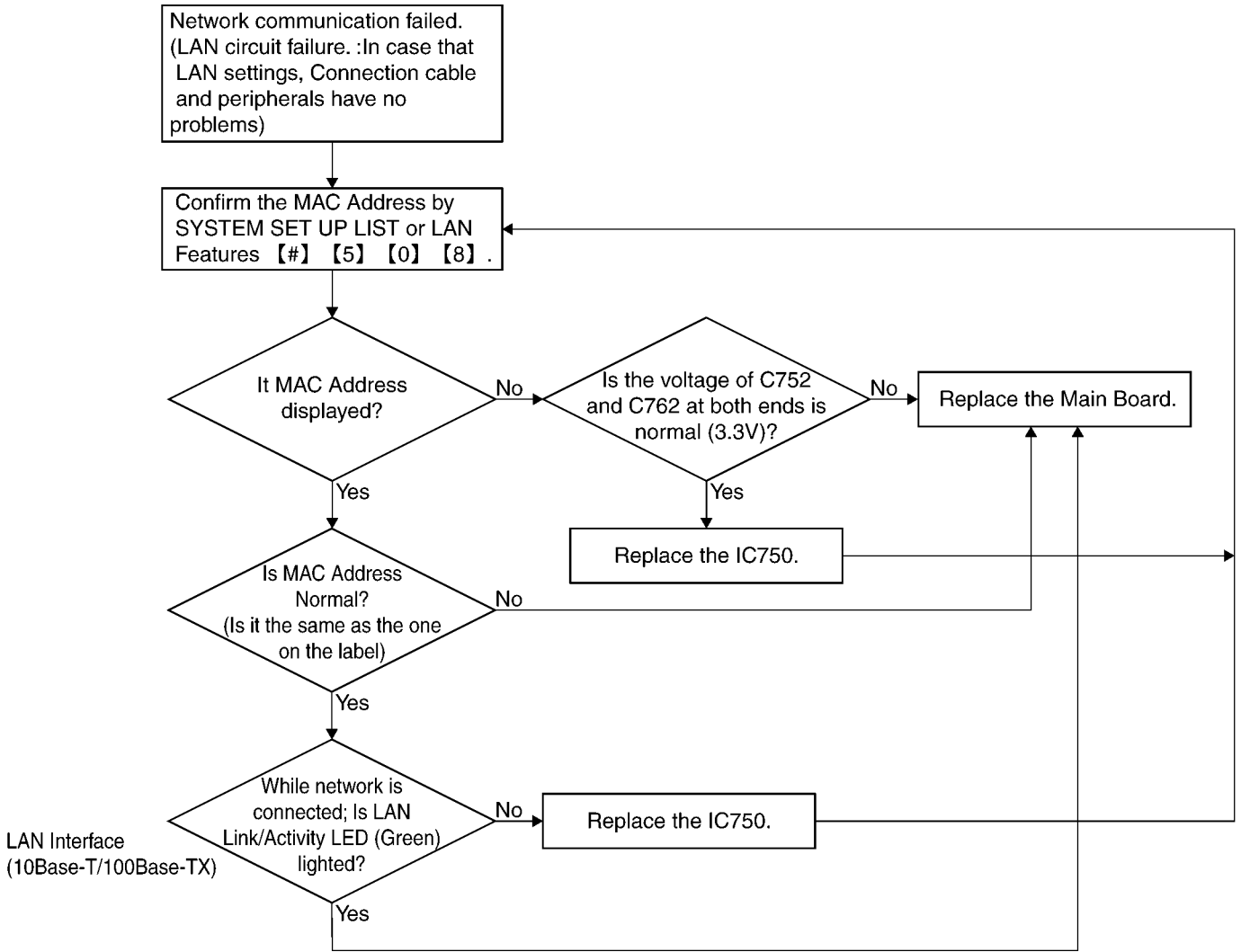

LAN Circuit signal waveform (Normal)

Transmitter waveform [TD+ (CN750 pin1), TD- (CN750 pin2) differential voltage] : Differential probe is used.

1. When network equipment is not connected (LAN cable is not connected);

① Auto negotiation waveform 1

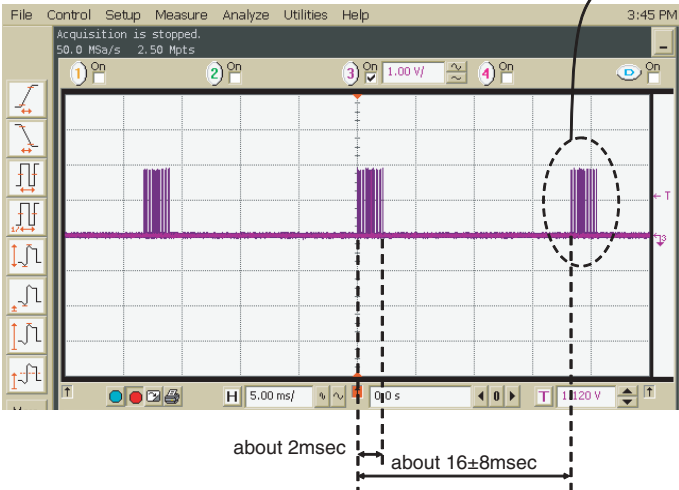

② Auto negotiation waveform 2 (A part of the waveform1 is magnified.)

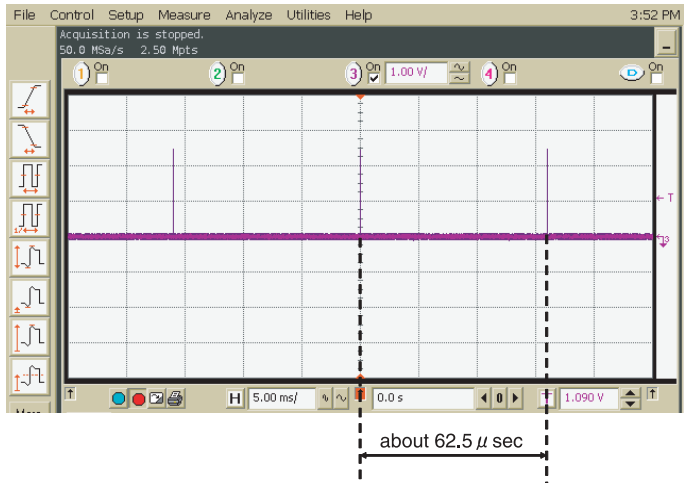

2. When 100Base-TX-enabled device is connected;

① 100Base-TX waveform 1

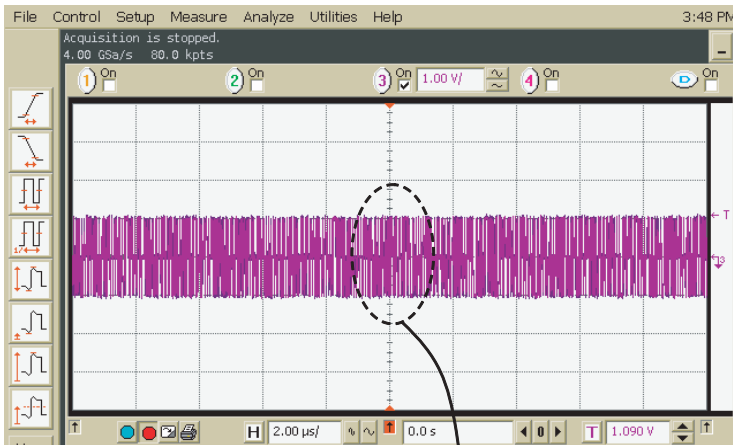

② 100Base-TX waveform 2 (A part of the waveform1 is magnified.)



3. When 10Base-T-enabled device is connected.

① 10Base-T waveform 1 [Link Pulse]

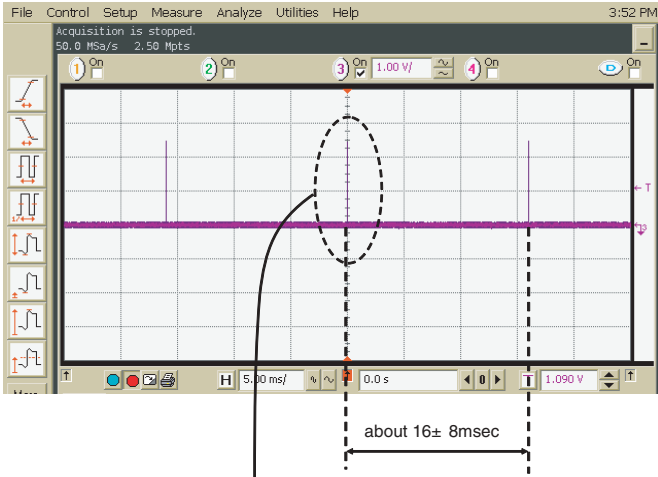

② 10Base-T waveform 2 [Link Pulse]
(A part of the waveform 1 is magnified.)

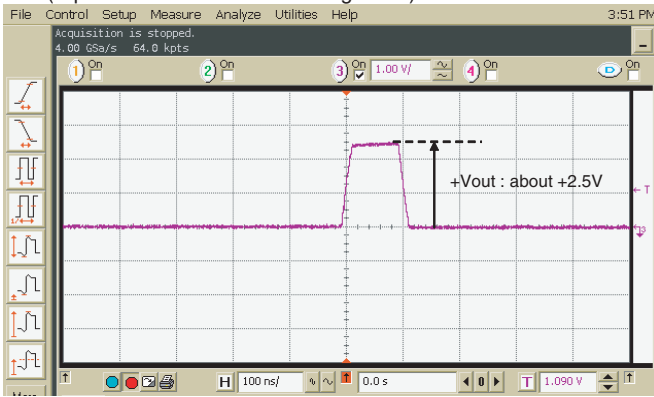

③ 10Base-T waveform 3 [during data commnication]

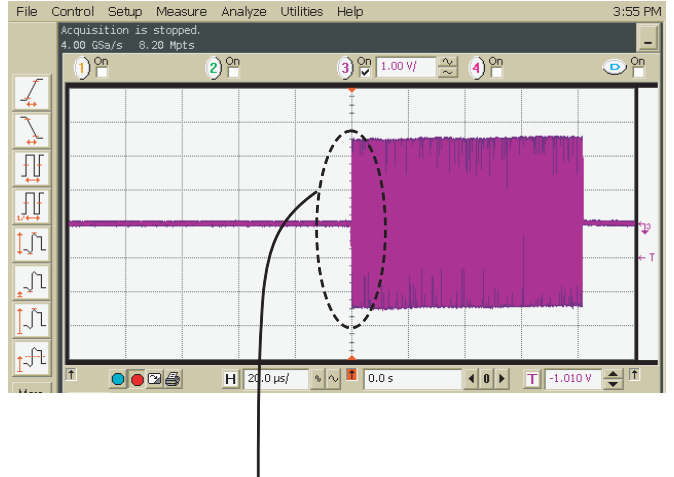

④ 10Base-T waveform 4 [during data commnication]
(A part of the waveform 3 is magnified.)

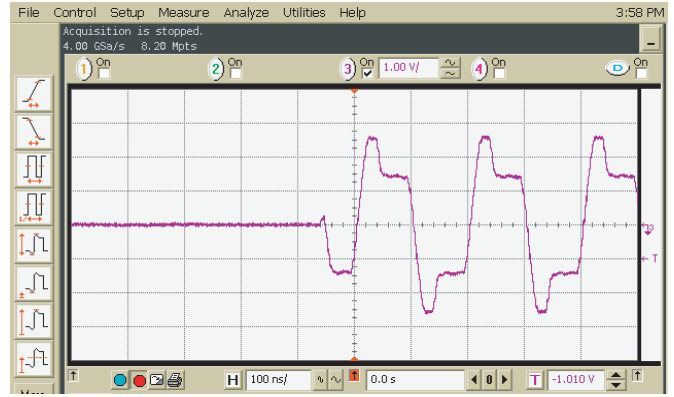

12.3.22. Main Board Section

Main Unit Power Supply Troubleshooting Guide (1)

+24VA.+24VB/S5V/S3.3V Troubleshooting

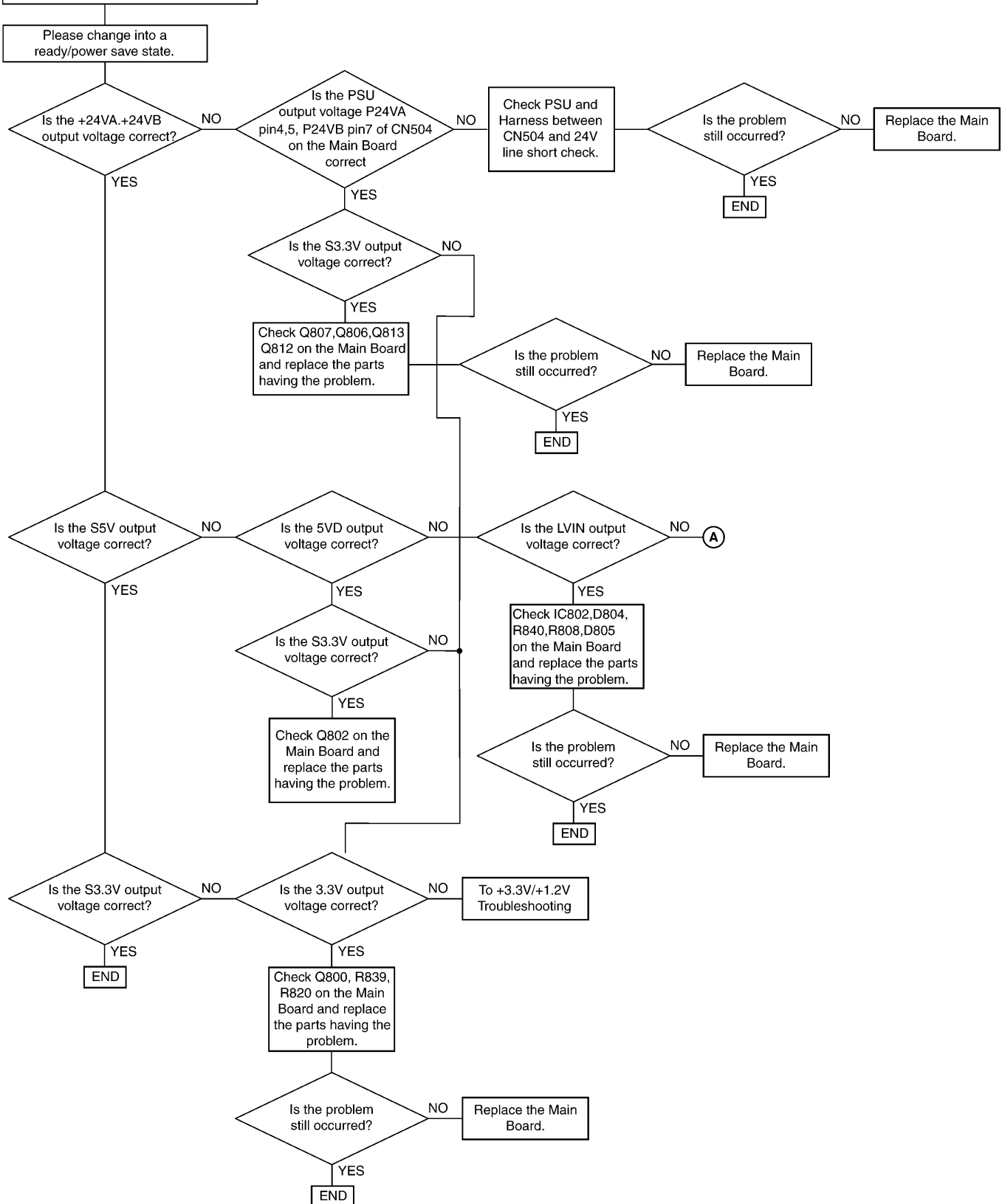

Main Unit Power Supply Troubleshooting Guide (2)

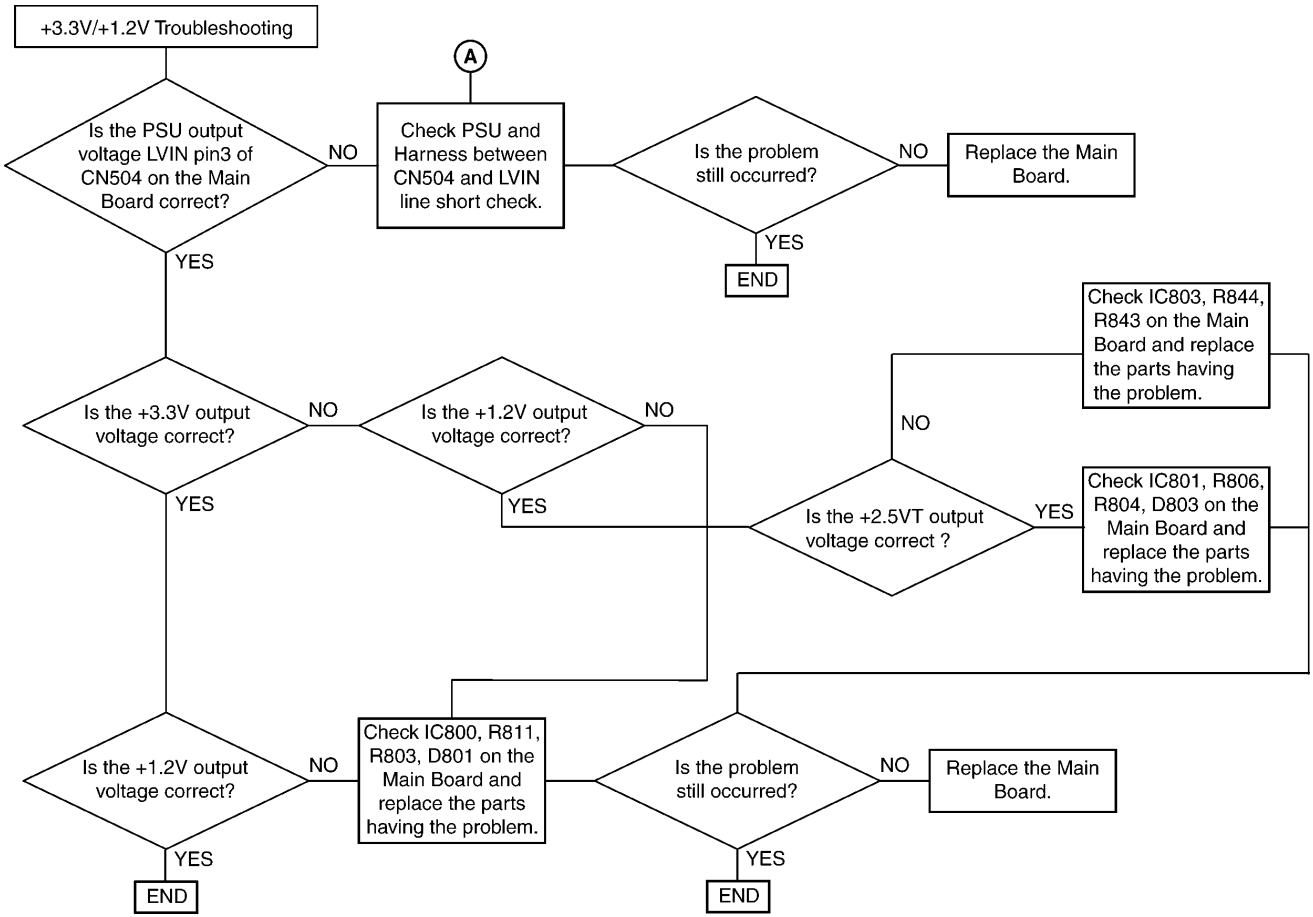

12.3.23. Low Voltage Power Supply Board (SMPS Board)Section

12.3.23.1. Key Components for Troubleshooting

Check the following parts first: F1, F2, D10, C5, Q1 and IC1.

This comes from our experience with experimental test. For example: power supply and lightning surge voltage test, with standing voltage test, intentional short circuit test, etc.

Caution:

If you find a melted fuse in the unit, do not turn on the power until you located and repair the faulty parts (except for the fuse); otherwise the fuse will melt again and you cannot pinpoint the faulty point.

In most cases, the symptom is that nothing is output. It is more likely that the fault is in the primary side rather than the secondary side. Check the primary side first.

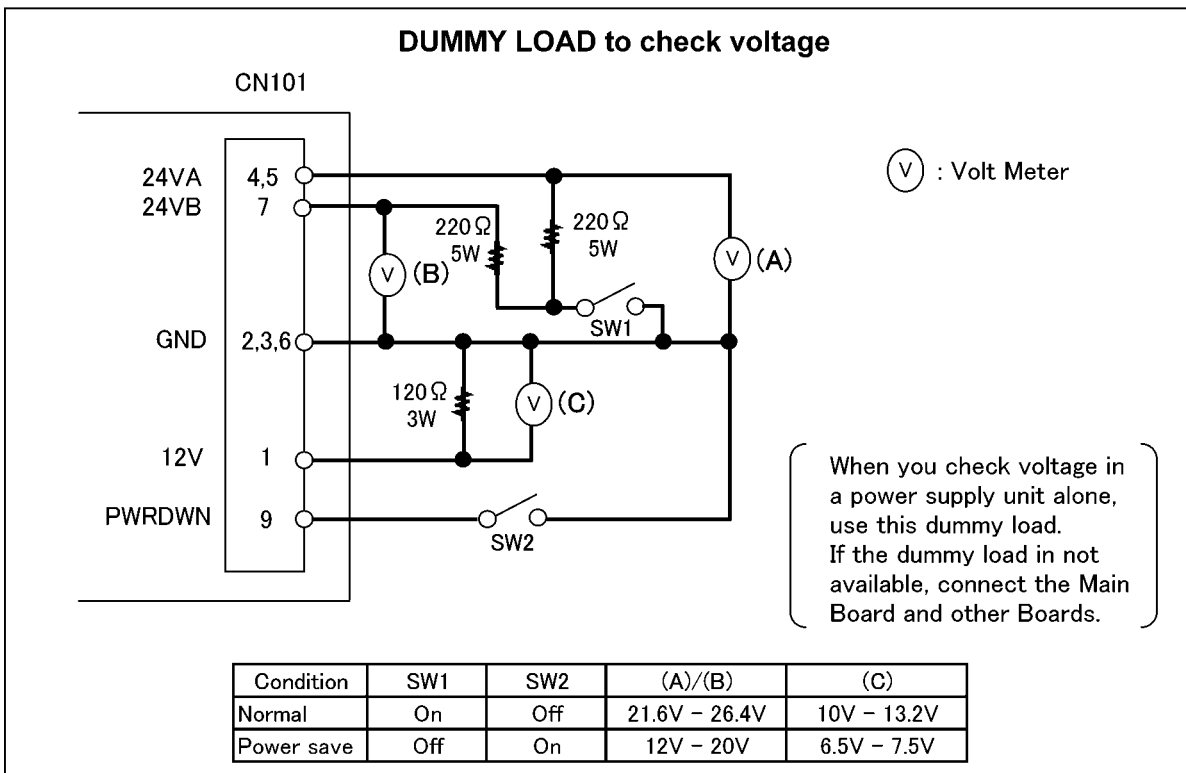
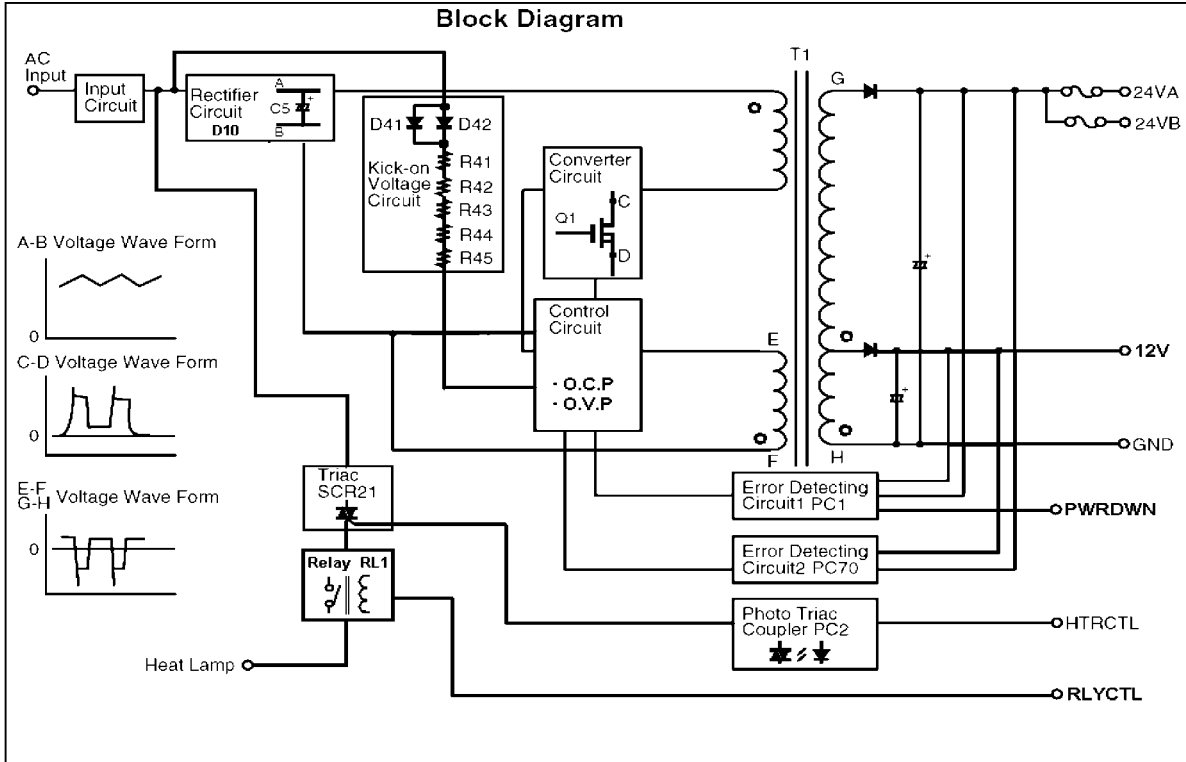

12.3.23.2. Troubleshooting Flow Chart

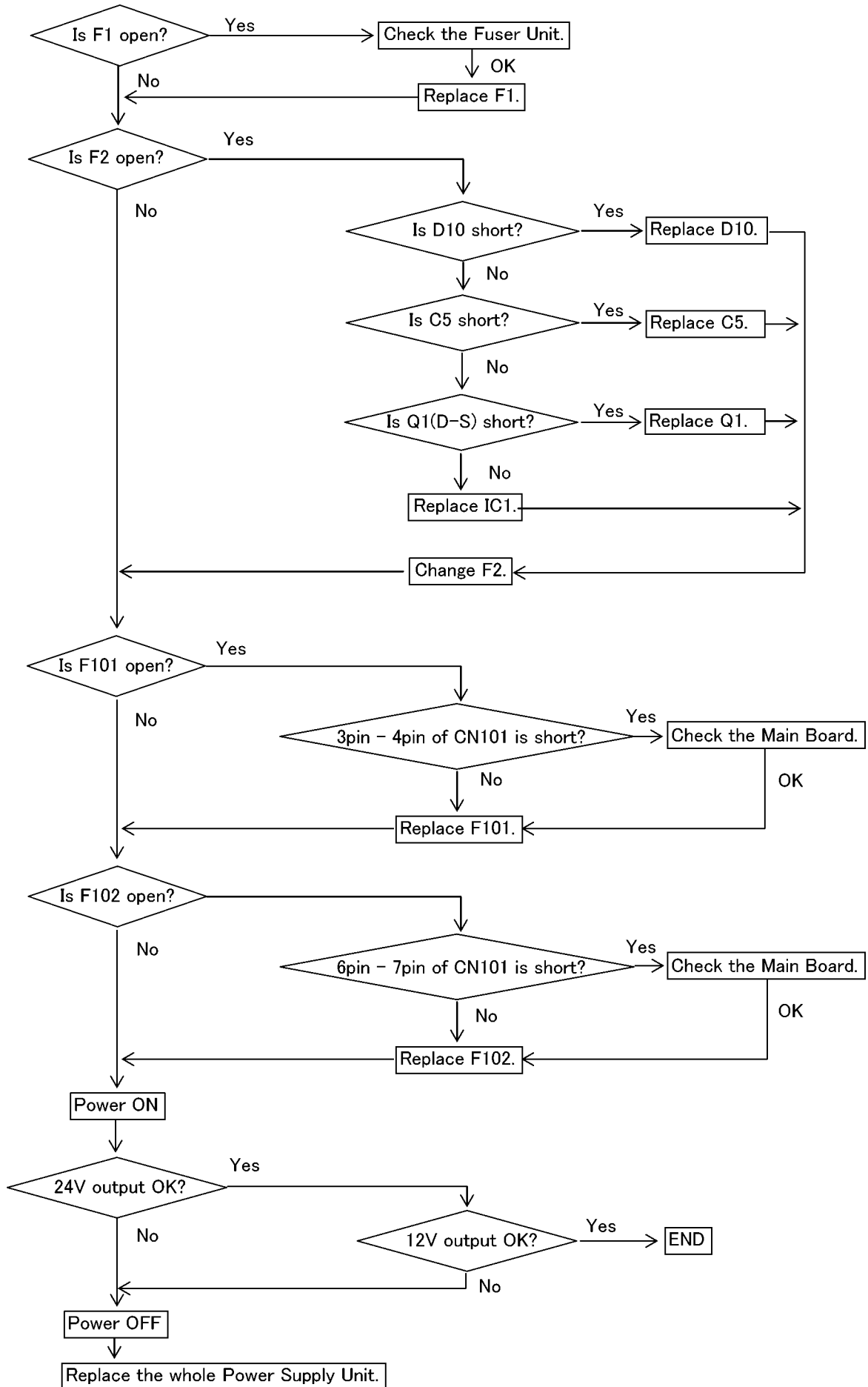

12.3.23.3. Broken Parts Repair Details

(D10)
 If D10 is short-circuit, F2 will melt (open).
 In this case, replace the parts (D10 and F2).

(Q1)
 The worst case of Q1 is a short-circuit between the Drain and Gate because damage expands to the peripheral circuit of Q1. This is due to a very high voltage through the Gate circuit, which is composed of IC1. You should change all of the parts listed as follows.
 • F2, Q1, IC1

(C5)
 If over voltage (more than AC320V) was supplied for a Low Voltage Power Supply board (SMPS Board), C5 will be broken.

(F101)
 If F101 is melted (open), check the 24VA lines of the Main board and others.

(F102)
 If F102 is melted (open), check the 24VB lines of the Main board and others.

12.3.24. Wireless LAN Section

Wireless LAN Block Diagram

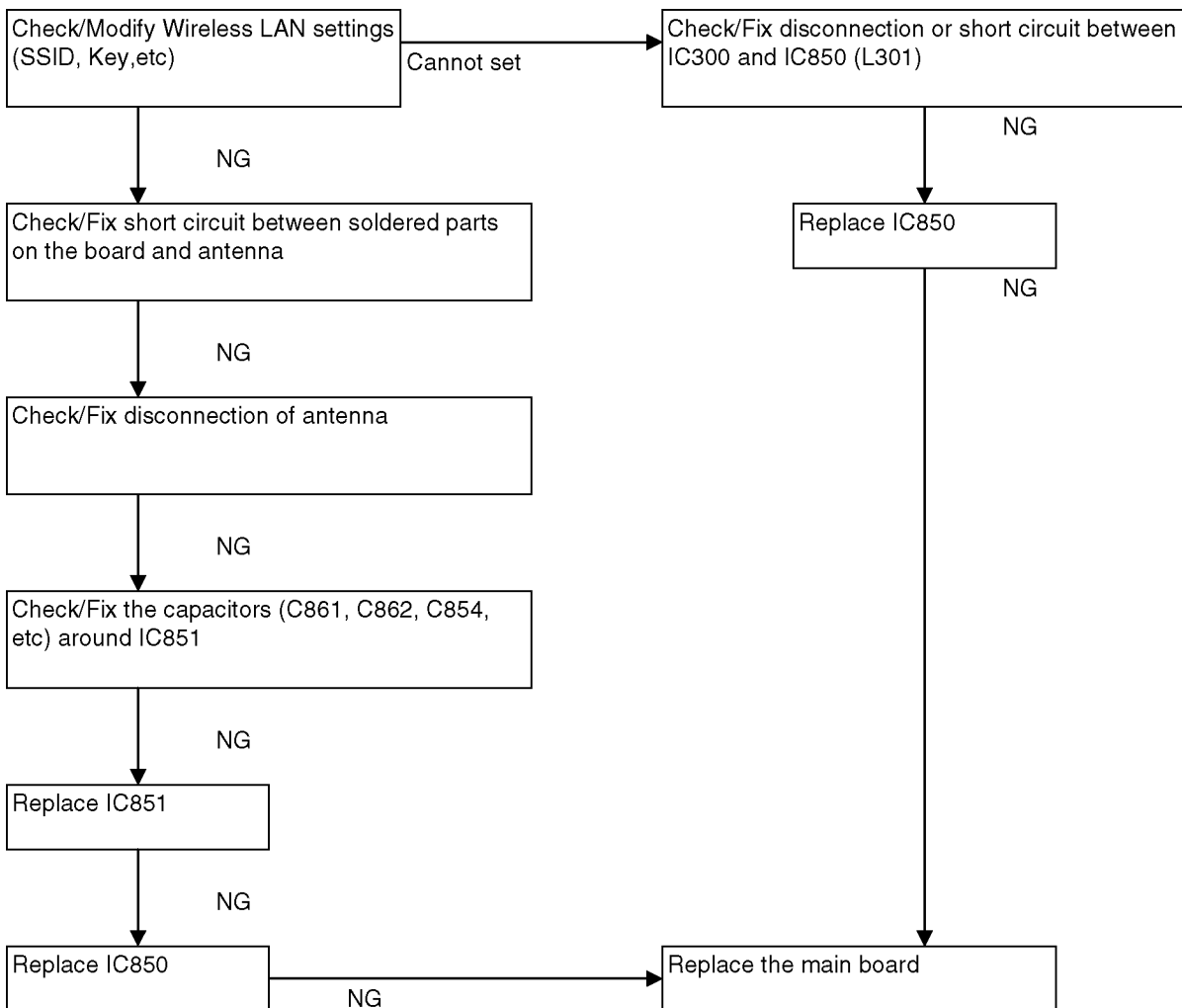

12.4. Recording Paper Jam

12.4.1. When the Recording Paper has Jammed Inside of the Unit

The display will show the following.

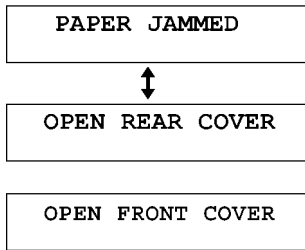

Caution:

- Do not pull out the jammed paper forcibly.

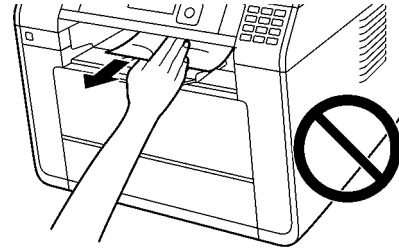

Important:

- Pull the standard input tray (1) until it clicks into place, then pull it completely out, lifting the front part of the tray.

If the lower input tray is installed, pull it out too. If there is any jammed paper, remove it.

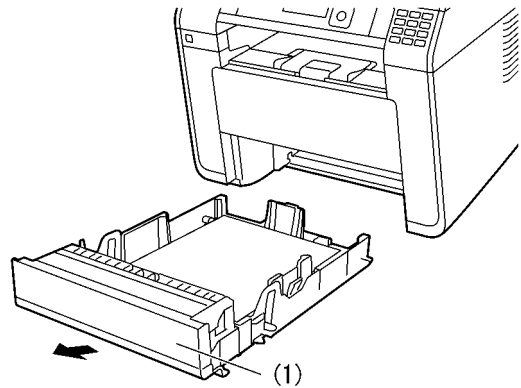

Case 1:

When the recording paper has jammed near the standard input tray:

1. Press the release button (1) to make open the bottom cover of the unit (2) halfway.

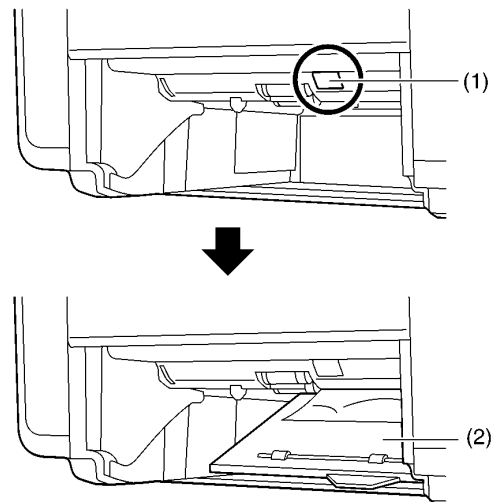

2. Remove the jammed paper (1).

- Depending on how the paper is jammed, it may not be easy to see. Please look inside from a lower angle to find the jammed paper.

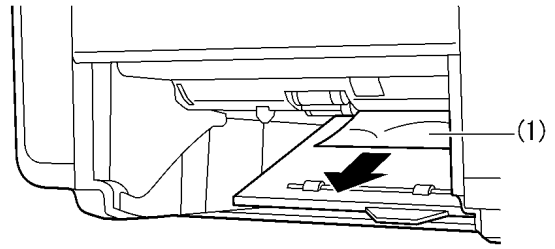

3. Close the bottom cover until it locks into place.

Important:

- Make sure that the bottom cover is completely closed.

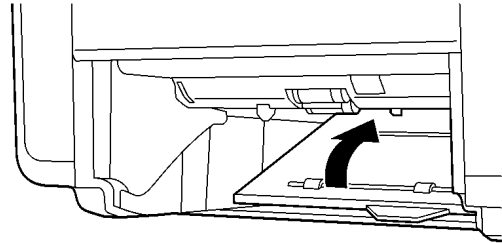

Case 2:

When the recording paper has jammed inside the rear cover:

1. Open the rear cover (1).

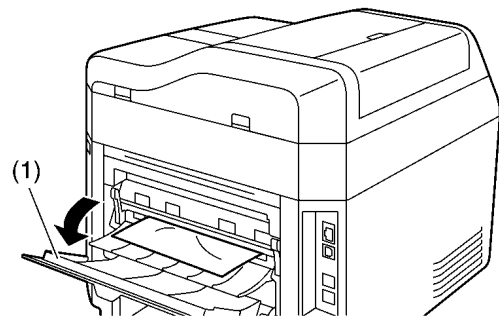

2. Push down both green levers (1) until they stop.

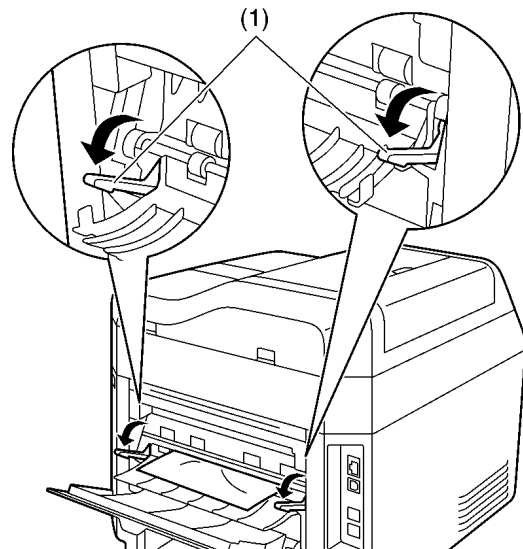

3. Remove the jammed paper (1) carefully by pulling it toward you.

Note:

- The area near the rear cover (3) may also get warm.
- If the recording paper cannot be removed from rear side, open the top cover, and then remove the jammed paper (4). After removing it, close the top cover.

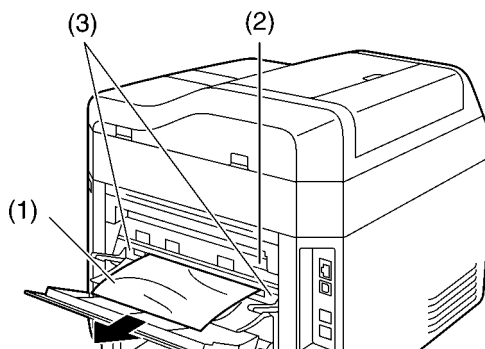

Caution:
The fuser unit (2) gets hot. Do not touch it.

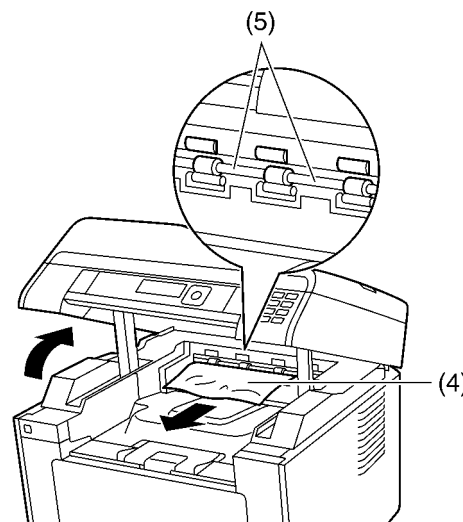

Caution:
Near the recording paper exit roller shaft (5) gets hot. Do not touch it.

4. Push up the green levers (1) to the original position.

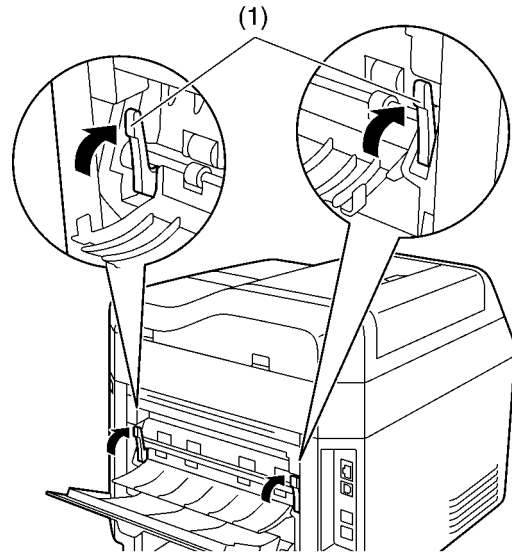

5. Close the rear cover firmly.

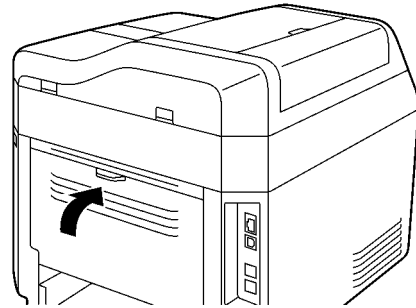

Case 3:

When the recording paper has jammed inside the front cover:

1. Press the button (1) and open the front cover.

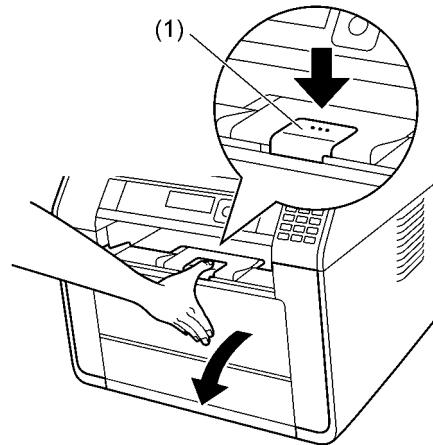

2. Remove the toner cartridge (1).

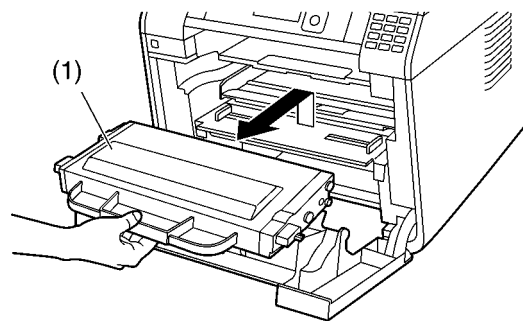

3. Remove the drum cartridge (1).

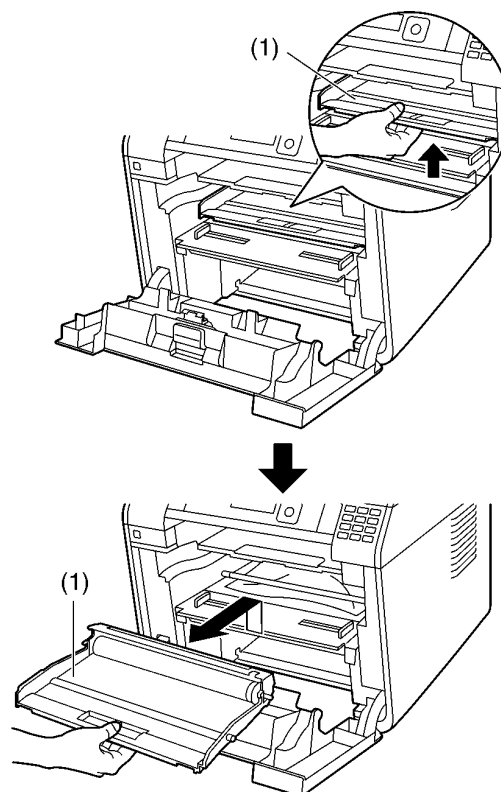

4. Remove the jammed paper.

- If the bottom edge of the recording paper (1) is under the roller, push the recording paper towards the back of the machine until it is released and then pull it out.

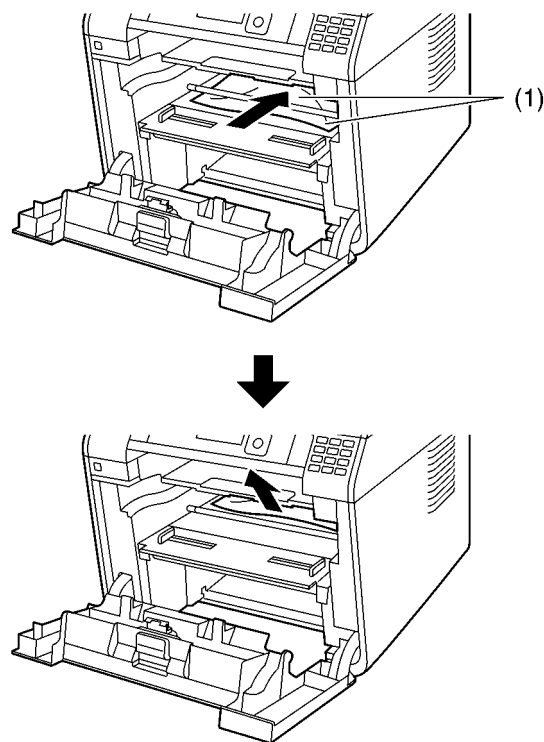

- If the top edge of the recording paper (2) is sticking out, pull it out by holding the front part of the jammed paper.

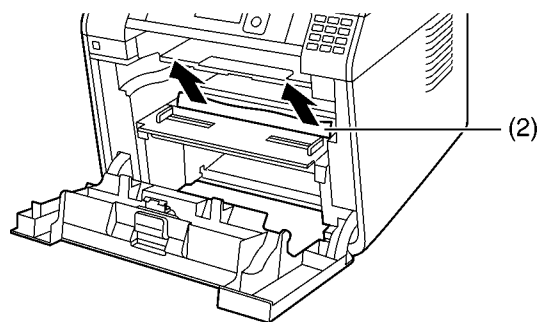

- After the jammed paper has been removed, re-insert the toner cartridge and drum cartridge into the unit.
5. Close the front cover to clear the error message, then insert the paper input tray.

12.4.2. When the Recording Paper is not Fed Into the Unit Properly

The display will show the following.

<p>CHECK PICK UP INPUT TRAY #1</p>
--

1. Pull the standard input tray completely out.
2. Re-load the recording paper.

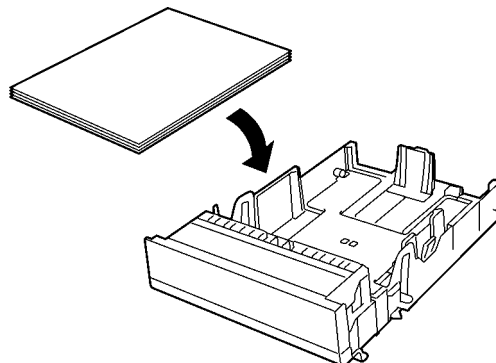

3. Insert the standard input tray into the unit.

Note:

- If the message is still displayed, check the recording paper specifications and load the recording paper again.

12.4.3. When the recording paper in the manual tray/multi-purpose tray is not fed into the unit properly

The display will show the following.

<p>CHECK PICK UP INPUT TRAY #2</p>
--

1. Remove the recording paper.
2. Re-insert the recording paper.

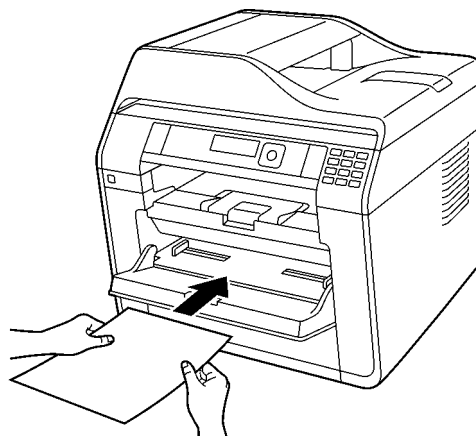

Note:

- If the message is still displayed, check the recording paper specifications and re-install recording paper.

12.5. Document jams (Automatic document feeder)

The display will show the following.

REMOVE DOCUMENT

Caution:

- Do not pull out the jammed document forcibly before lifting the ADF cover.



1. Open the ADF cover (1) while holding down the document cover (2).

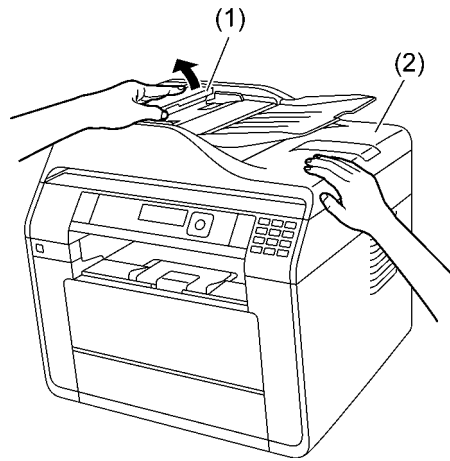

2. Remove the jammed document (1) carefully.
When the document has jammed near the document entrance:



- If you cannot remove the jammed document (1), open the document cover, remove the document, then close the document cover.

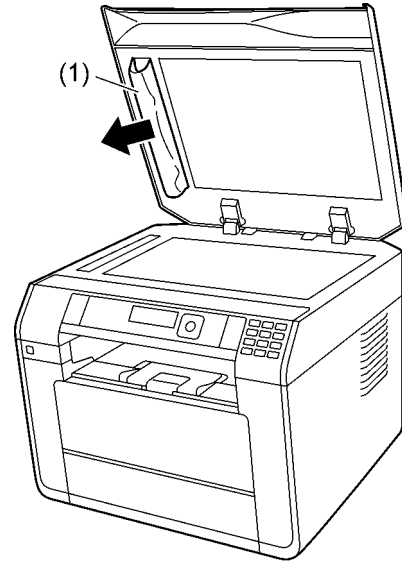

When the document has jammed near the document exit:



- If you cannot remove the jammed document, open the internal cover (2), remove the document (1), then close the cover.



3. Close the ADF cover.

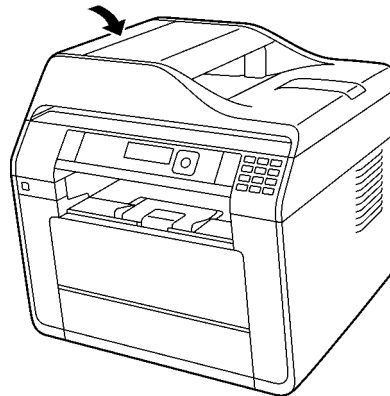

• Press  to clear the message.

13 Service Fixture & Tools

How to extend cords

When extending cords, you need 2 pairs of A,B (A=connector,B=cord)
 (One pair is connected to the Main board.)
 If you do not have 2 pairs, order the necessary parts.

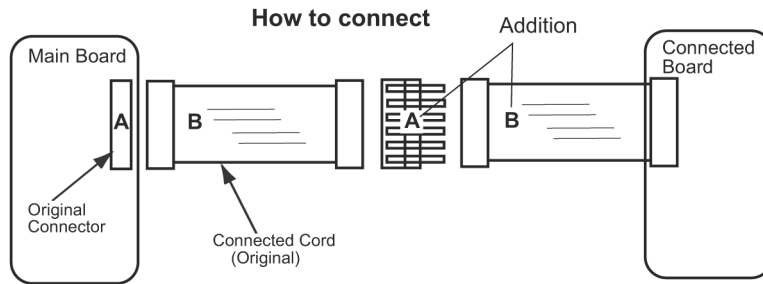

NOTE

Be sure if the direction of the connectors are correct.

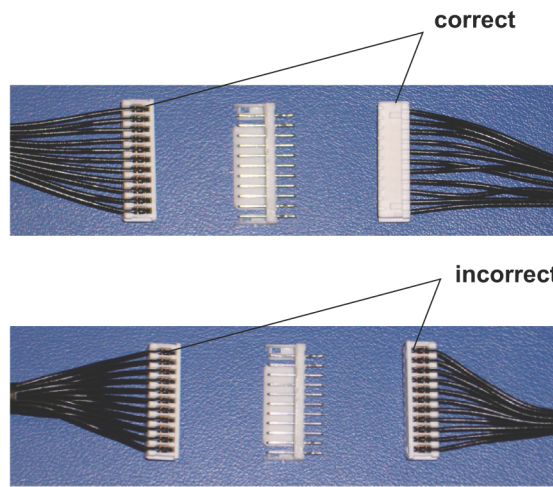

KX-MB1510

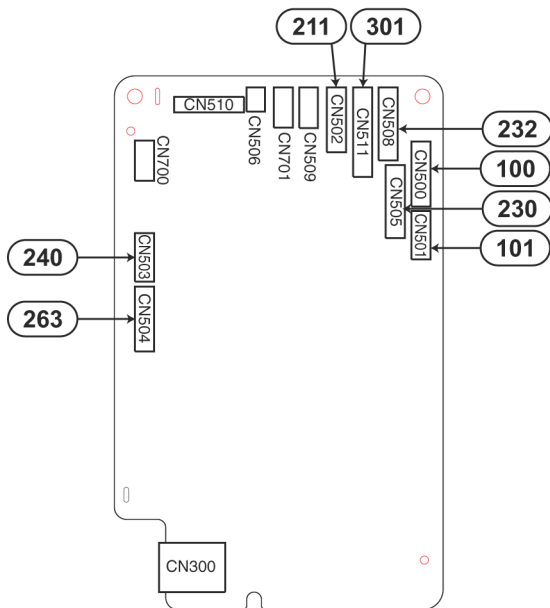

KX-MB1536

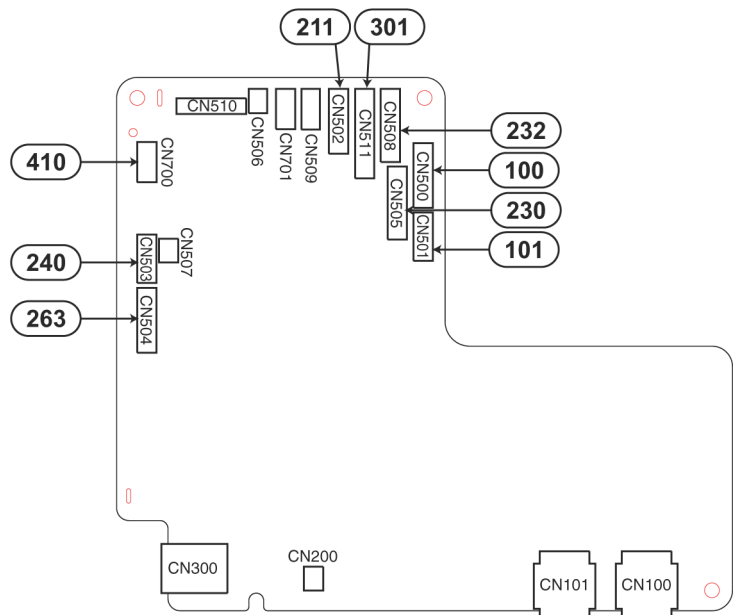

14 Disassembly and Assembly Instructions

14.1. First of All

Before performing the following steps, unplug the AC power cord, then remove the toner and drum cartridges and the Standard Input Tray from the Printer.

1. Remove the Standard Input Tray.

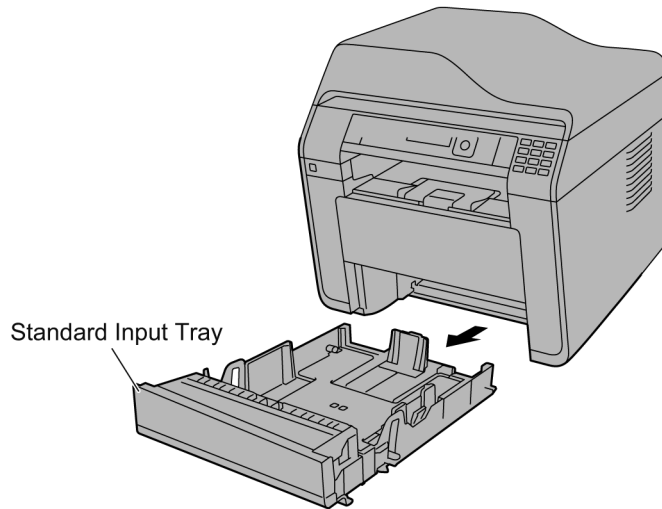

2. Open the Front Cover.

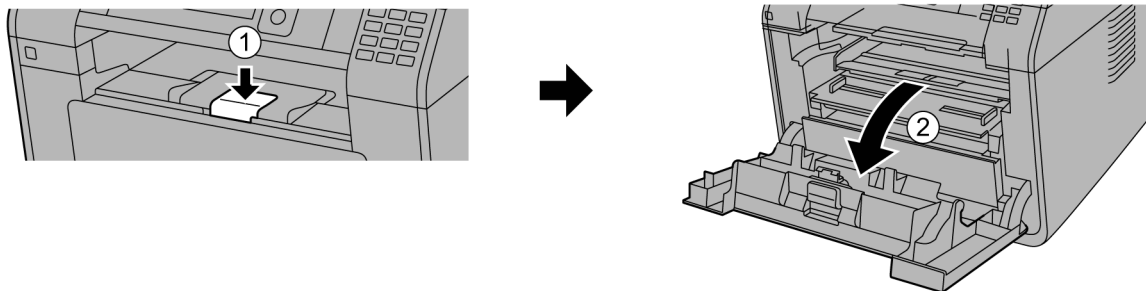

3. Remove the Toner Cartridge.

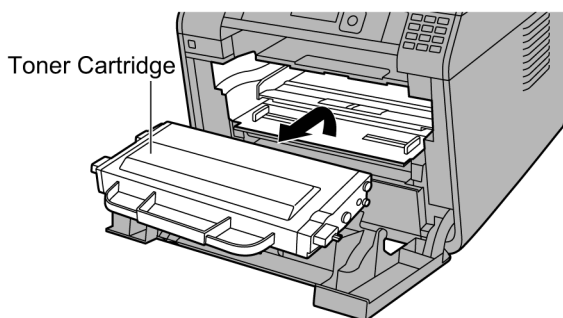

4. Remove the Drum Cartridge.

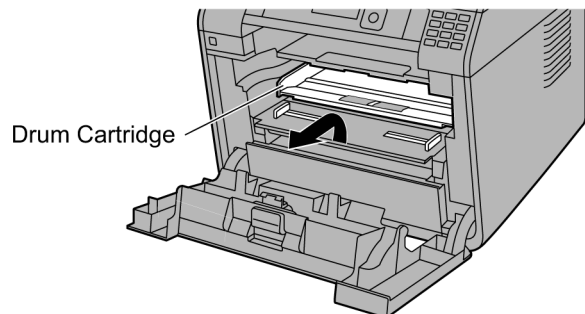

14.2. Flow Chart for Disassembly

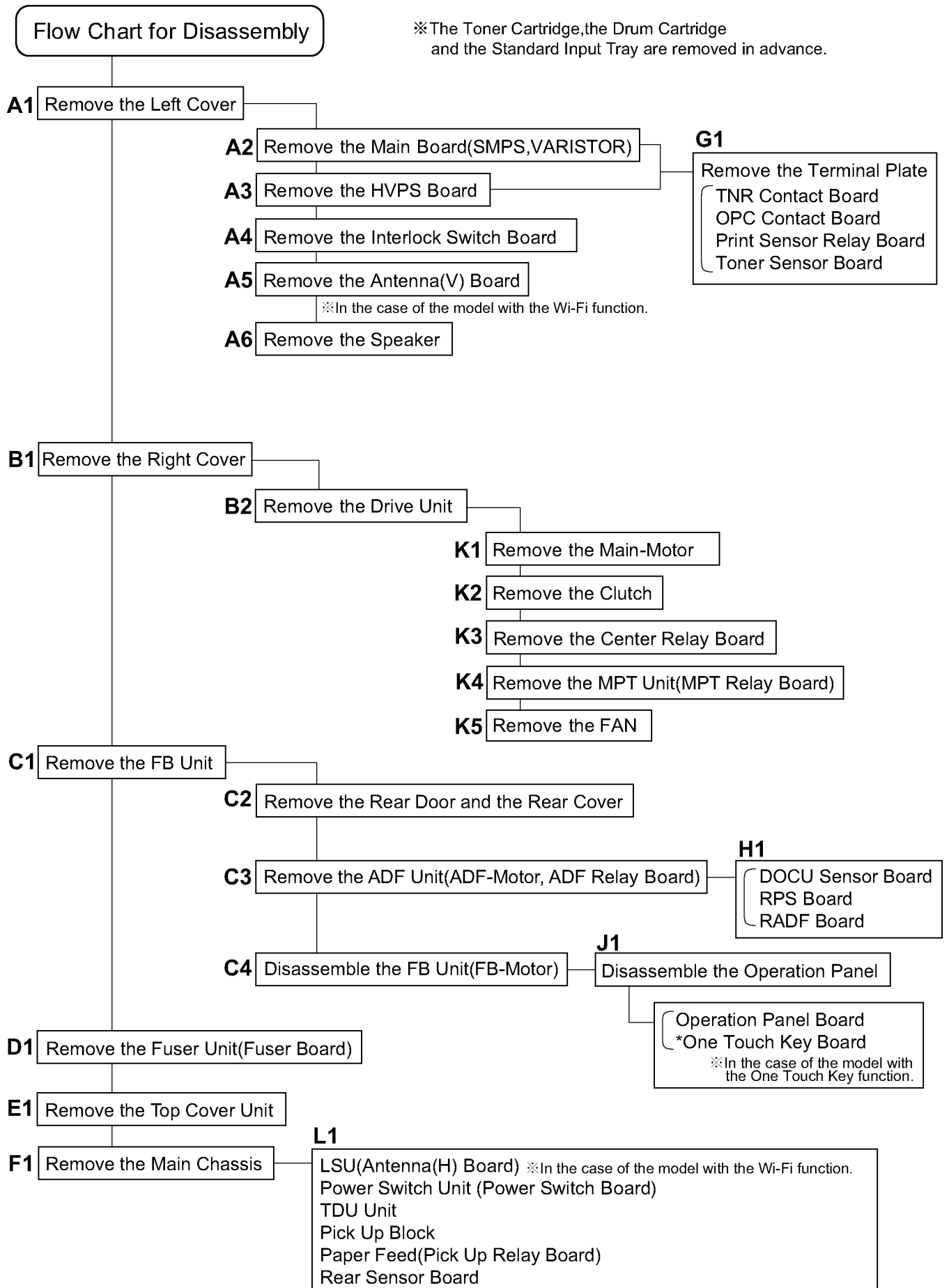

14.3. Disassembly for Main Parts

14.3.1. Remove the Left Cover

A1

- 1) Open the FB Unit.
- 2) Open the Front Cover.
- 3) Remove the 3 screws(A).
- 4) Remove the Left Cover.

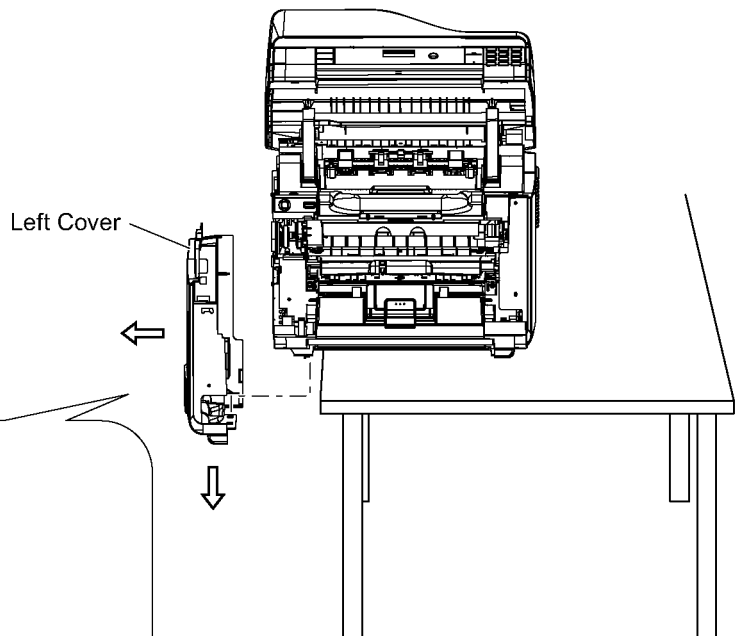
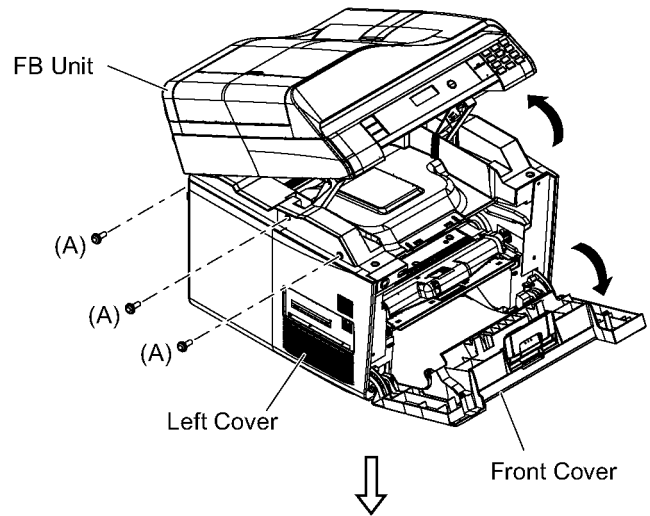

How to remove a cover

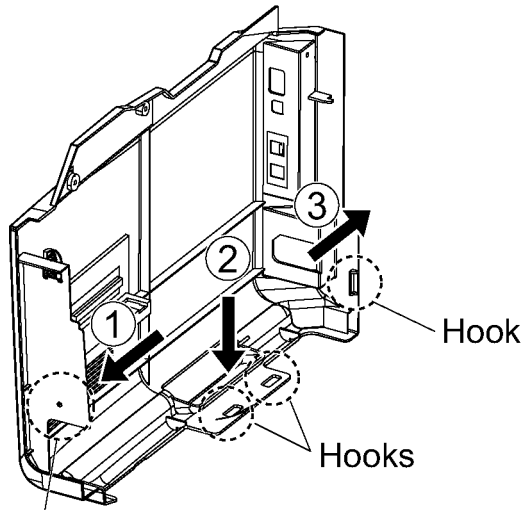

The hole of boss

※ Remove the left cover by releasing Hooks and by raising a little upward.

14.3.2. Remove the Main Board (SMPS Board, VARISTOR Board)

A2

- 1) Remove the all Connectors on the Main Board.
- 2) Remove the coaxial cable [from an Antenna (V) Board and an Antenna (H) Board] currently fixed to the Main Board.
(※ In the case of the model with the Wi-Fi function.)

The position of the 2 coaxial cables to desolder

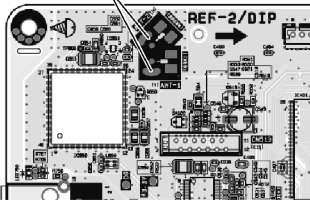

- 3) Remove the 6 screws(B).
- 4) Remove the Earth Lead.
- 5) Remove the Main Board.

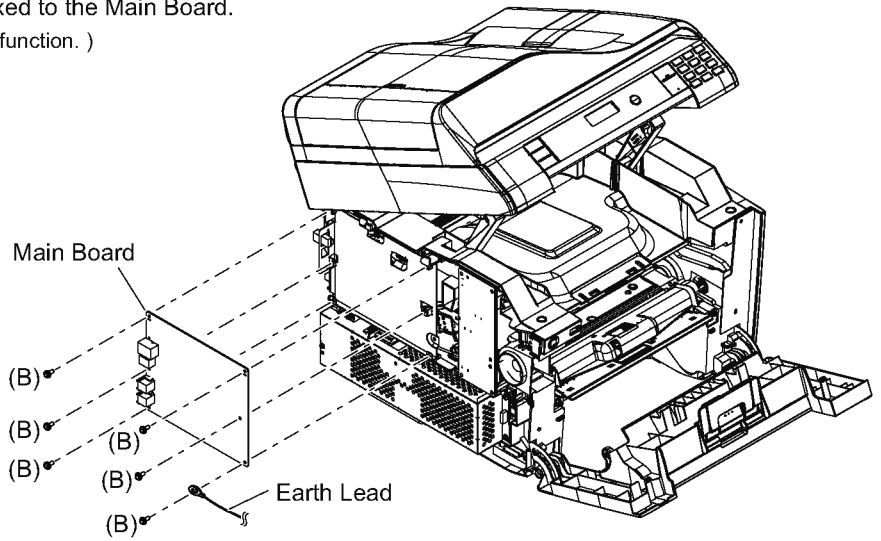

<Caution of assembly>

Detail of UNIT/ANTENNA and Antenna Board soldering
(Refer to the 307-309pages)

- 6) Remove the 5 screws(C) on the SMPS Board (Power Board) Shield Cover.
- 7) Remove the Earth Lead.
- 8) Remove the SMPS Board (Power Board) Shield Cover.

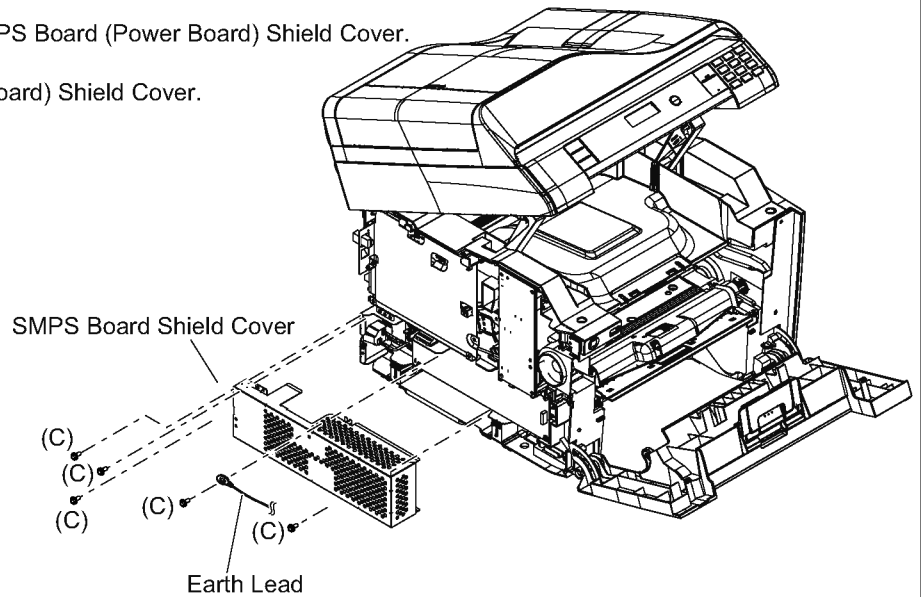

<Caution of assembly>

Detail of LEAD wire dressing
(Refer to the 315pages)

Be careful that this lead is Hot AC Line.

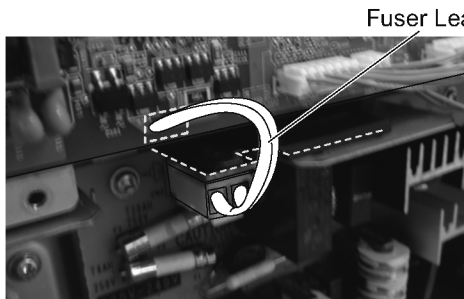

(Fuser leads passes the hole after the Main Board.)

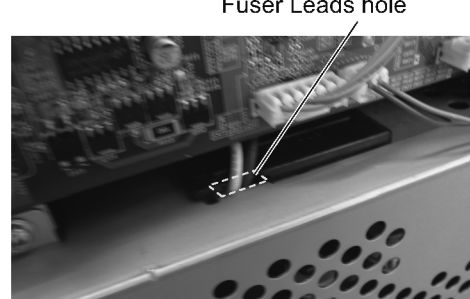

(Be careful not to be damaged the Fuser lead by the shield cover.)

A2

- 9) Remove the 4 screws (A) on the Main Board Plate.
- 10) Remove the 2 screws (B) on the Varistor Board.
- 11) Remove the Varistor Board.

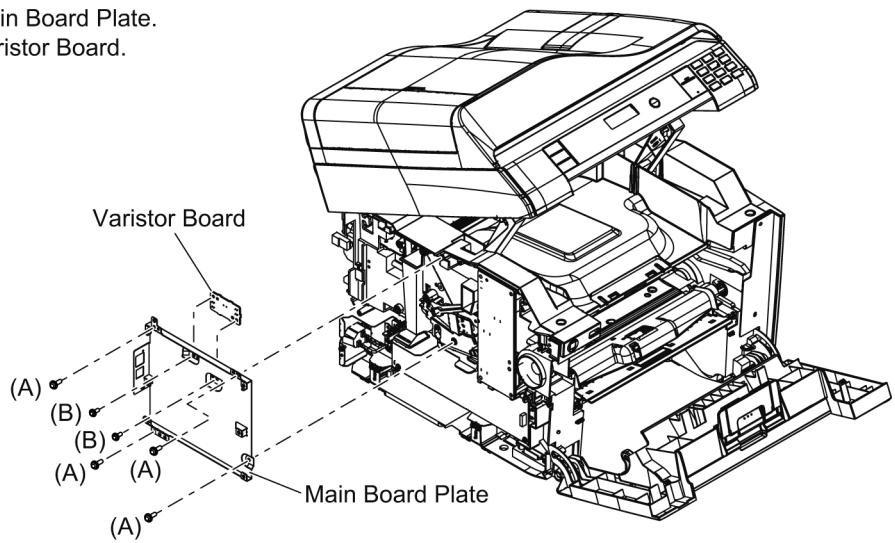

- 12) Remove the all Connectors on the SMPS Board.
- 13) Remove the 3 screws (A) and the 3 screws (C) on the SMPS Board Holder.
- 14) Remove the Earth Lead (AC Inlet).
- 15) Remove the 5 screws (C) on the SMPS Board.
- 16) Remove the SMPS Board.

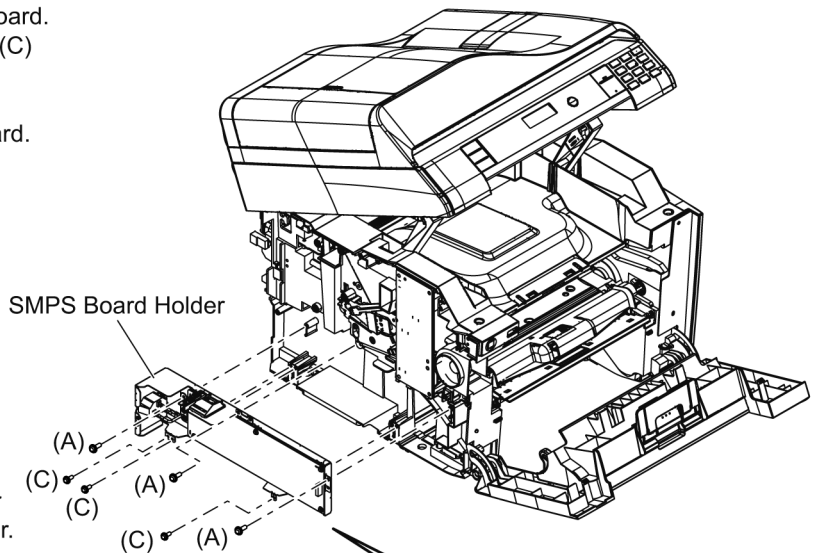

<Caution>

When you remove SMPS Board, do discharge the electric capacity of capacitor by short circuit of the terminals by 1kΩ resistor.

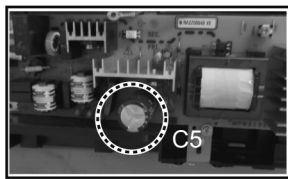
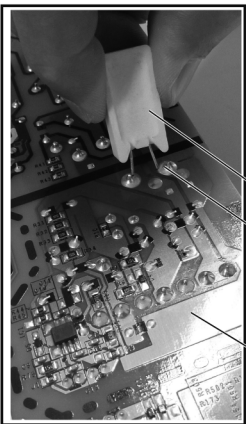

1kΩ Resistor
 short circuit between +/- terminal of the capacitor(C5) more than 5 sec.
 soldering side of SMPS Board

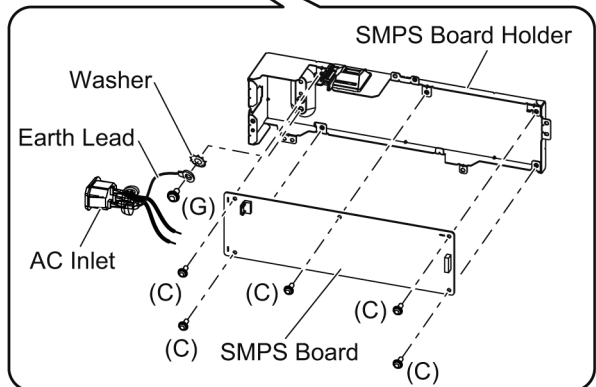

14.3.3. Remove the HVPS Board

A3

- 1) Remove the 6 screws(A).
- 2) Remove the Sheet Protect.
- 3) Remove the Connector on the HVPS Board.
- 4) Remove the HVPS Board.

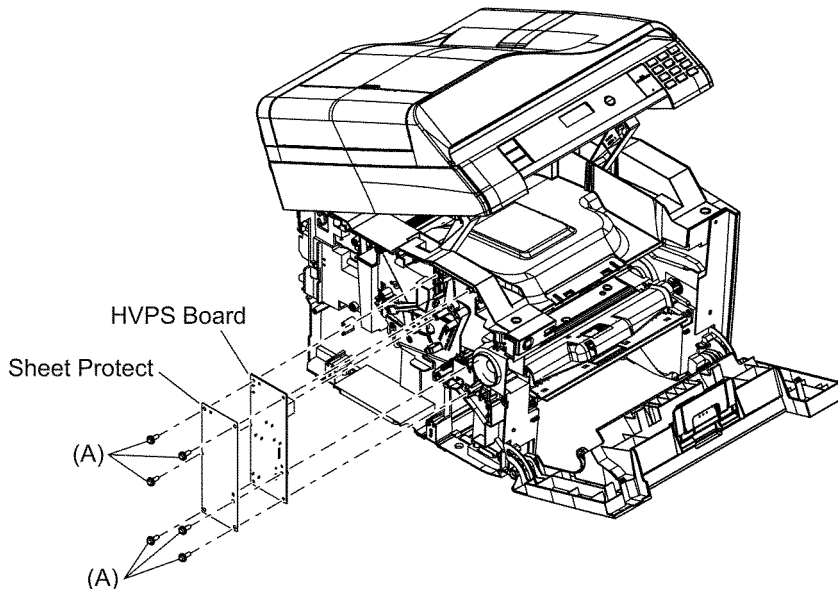

14.3.4. Remove the Interlock Switch Board

A4

- 1) Check that the Front Cover is open.
- 2) Remove the one screw (D) on the Interlock Switch Board.
- 3) Remove the Interlock Switch Board.
- 4) Remove the Connector on the Interlock Switch Board.

< Caution >

Be careful not to damage(deform) the Switch Plate of the Interlock Switch Board during remove / insert process from the machine.

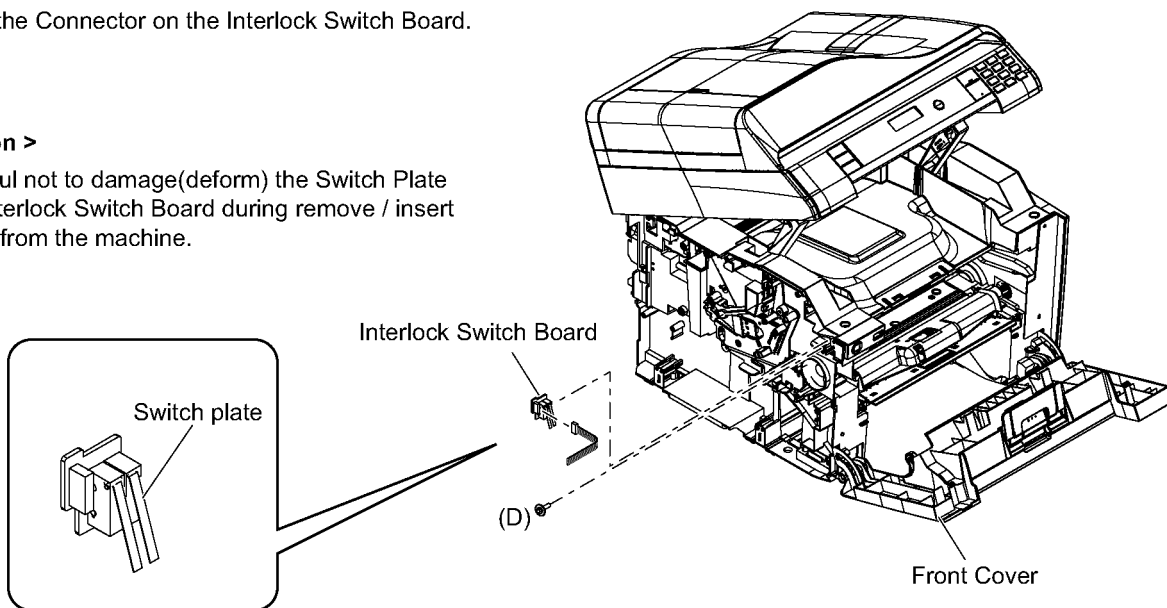

14.3.5. Remove the Antenna(V) Board

A5

- 1) Release the Antenna(V) Board from 2 Hooks.
- 2) Remove the Antenna(V) Board.

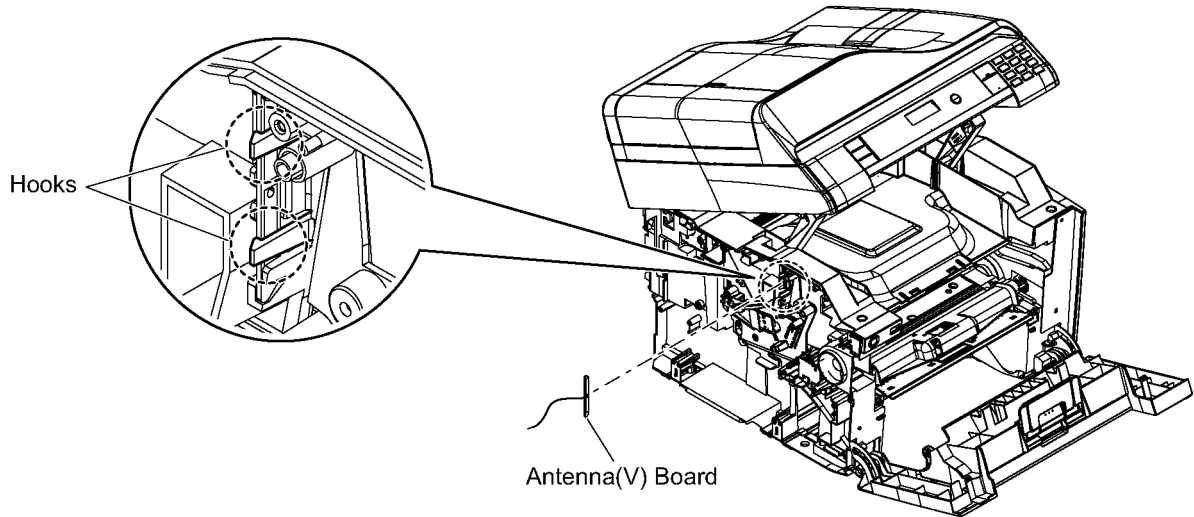

14.3.6. Remove the Speaker

A6

- 1) Remove the one screw (A).
- 2) Remove the spring on the Speaker.
- 3) Remove the Speaker by sliding it.

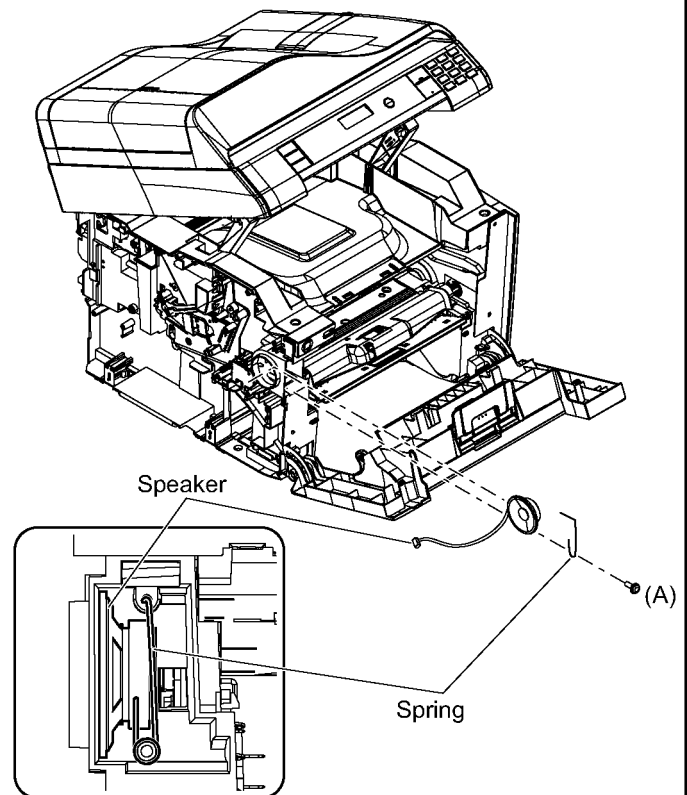

14.3.7. Remove the Terminal Plate/TNR Contact Board/OPC Contact Board/Print Sensor Relay Board/Toner Sensor Board

G1

- 1) A1: Remove the Left Cover
- 2) A2: Remove the Main Board and Main Board Plate
- 3) A3: Remove the HVPS Board
- 4) Remove the all leads on the hook from the Terminal Plate.
- 5) Remove the Antenna(V) Board from the Terminal Plate.

※ In the case of the model with the Wi-Fi function

- 6) Remove the 5 screws(A).
- 7) Release the 2 Hooks of the Terminal Plate.
- 8) Remove the Terminal Plate.

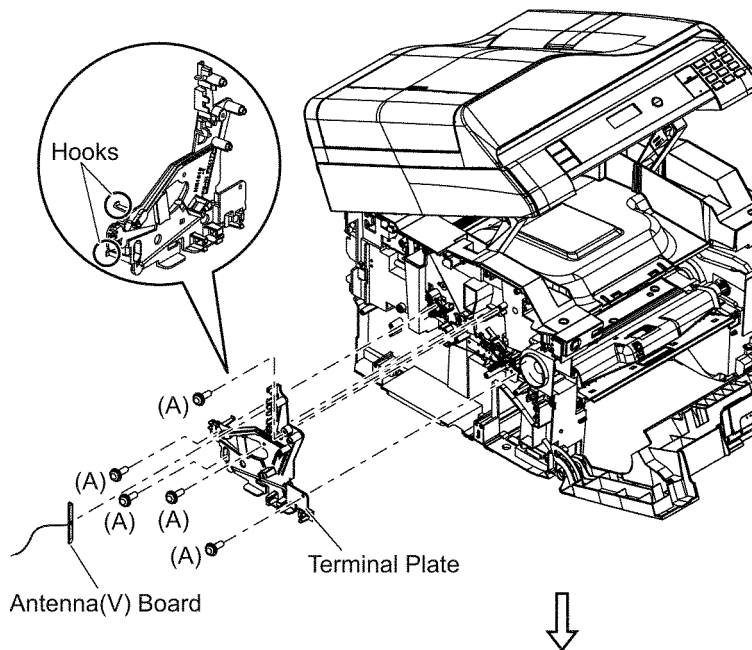

- 9) Remove the one screw(A) and one connector on the TNR Contact Board.
- 10) Remove the TNR Contact Board.
- 11) Remove the one screw(A) and one Connector on the OPC Contact Board.
- 12) Remove the OPC Contact Board.
- 13) Remove the one screw(A) and one Connector on the Print Sensor Relay Board and the Toner Sensor Board.
- 14) Remove the Print Sensor Relay Board and the Toner Sensor Board.

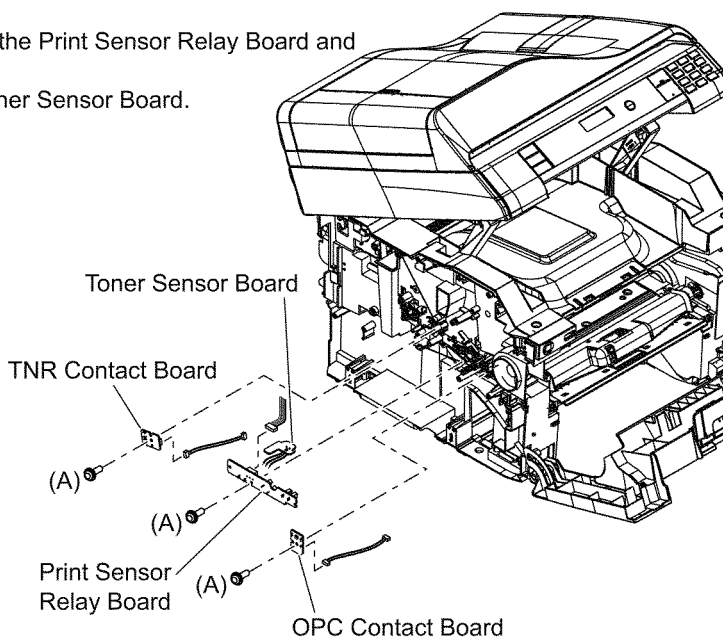

14.3.8. Remove the Right Cover

B1

- 1) Remove the 3 screws (A).
- 2) Remove the Right Cover.

<Caution>

When removing a cover, the Fan may come with the Right Cover. Please be careful.

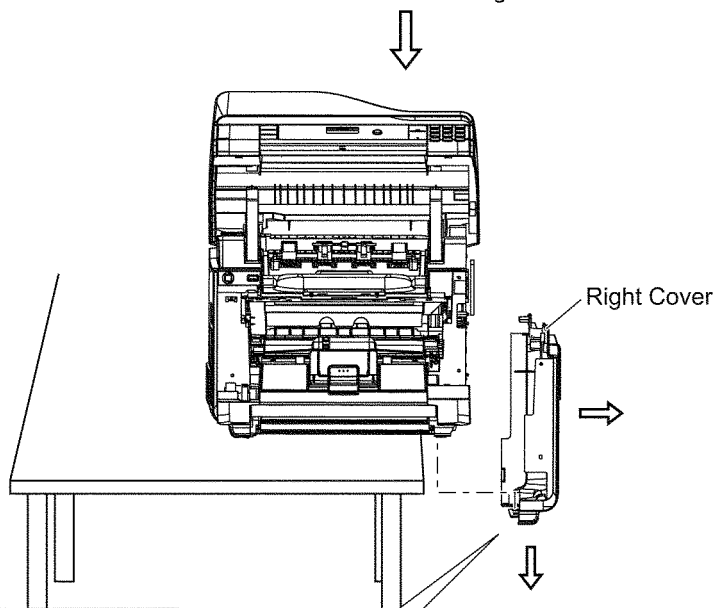
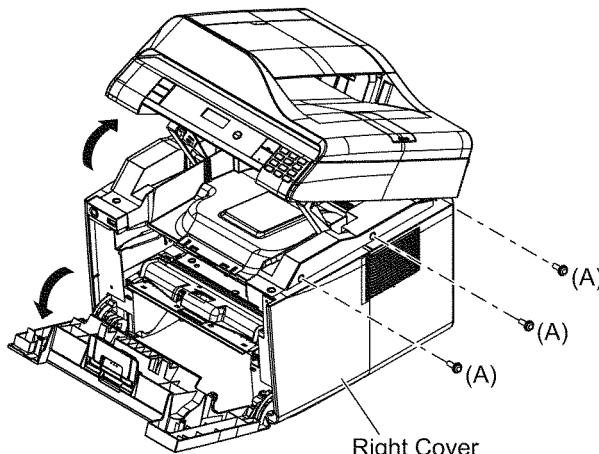
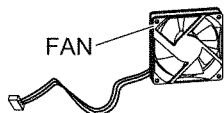

How to remove a cover

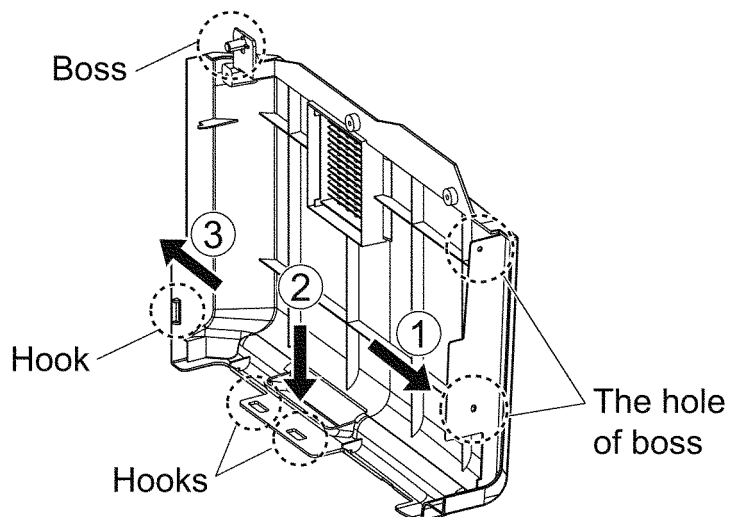

Remove the Right Cover by releasing Hooks and by raising a little upward. Also be careful about the boss.

14.3.9. Remove the Drive Unit

B2

[See the Fig1]

- 1) Remove the 6 screws (A) on the Main Motor ASSY.. (The 6 screws includes 2 Earth Leads.)
- 2) Remove the 2 screws (D).
- 3) Remove the Connector.
- 4) Remove the Main Motor ASSY..

- 5) Remove the 2 screws (C) which is fixing the Solenoid.(Two places)
- 6) Remove the Solenoids.(Two places)

[See the Fig2]

- 7) Remove the 2 screws (A).
- 8) Remove the ADU Gear Sheet.
- 9) Remove the screw (C) on the ADU Lever spring.
- 10) Remove the ADU Arm and remove the Gears.

[See the Fig3]

- 11) Remove the 3 screws (A).
- 12) Remove the Eject Gear Sheet.
- 13) Remove the screw (C) on the Switch Back Arm spring.
- 14) Remove the Switch Back Arm and remove the Gears.

<Caution of assembly>

Detail of SOLENOID LEAD wire dressing (Refer to the 312pages)

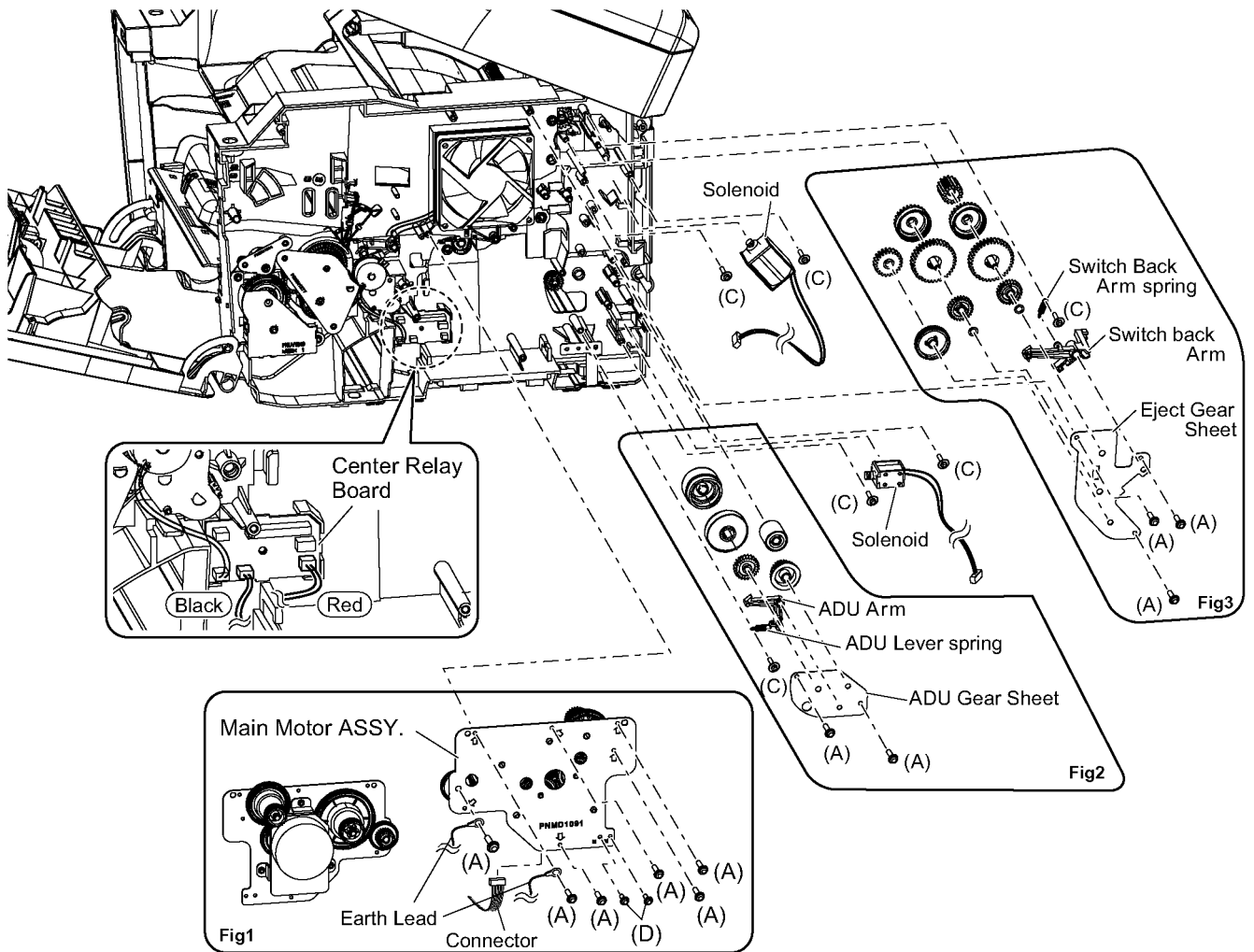

14.3.10. Remove the Main Motor

K1

- 1) Remove the 3 screws (C) to remove the Main Motor from Main Motor ASSY..

Main Motor ASSY.

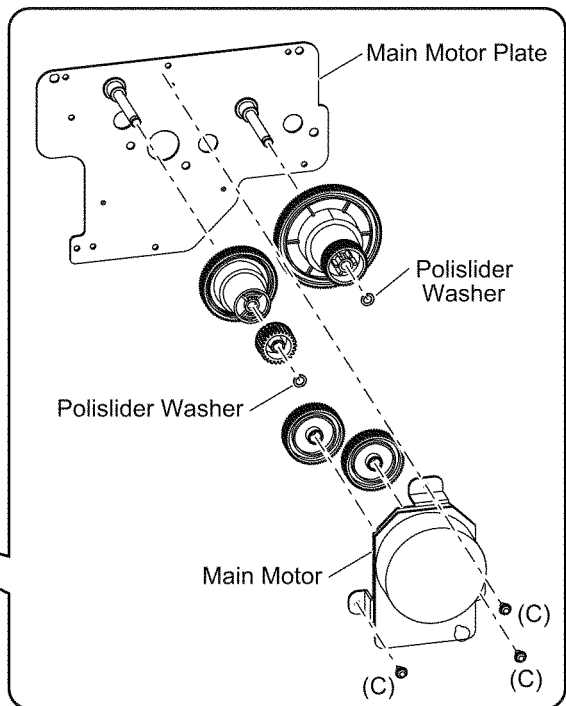
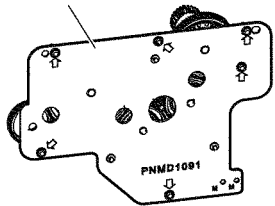

14.3.11. Remove the Clutch

K2

- 1) Remove the Connector on the Center Relay Board.
- 2) Remove the Polislider Washer on the Clutch.
- 3) Remove the Clutch.

<Caution of assembly>

Attach a clutch, as shown in the following figure.

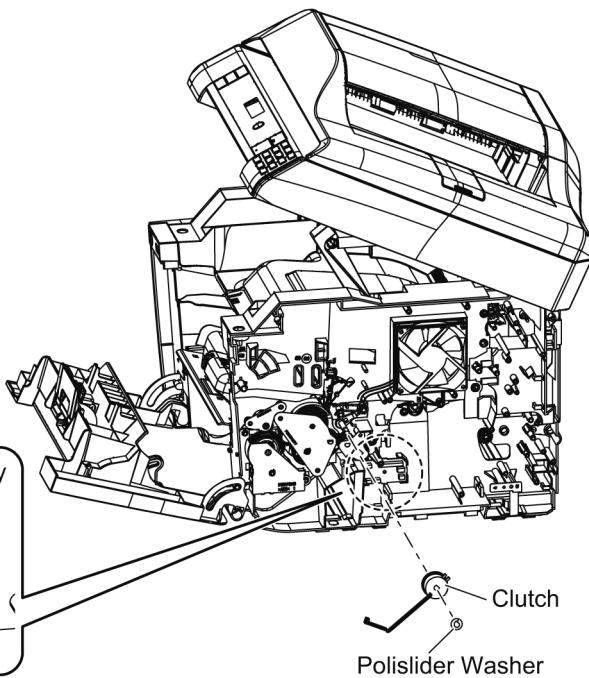
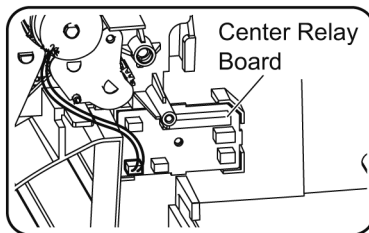

14.3.12. Remove the Center Relay Board

K3

- 1) Remove the all Connectors on the Center Relay Board.
- 2) Remove the one screw (A) .
- 3) Remove the Center Relay Board.

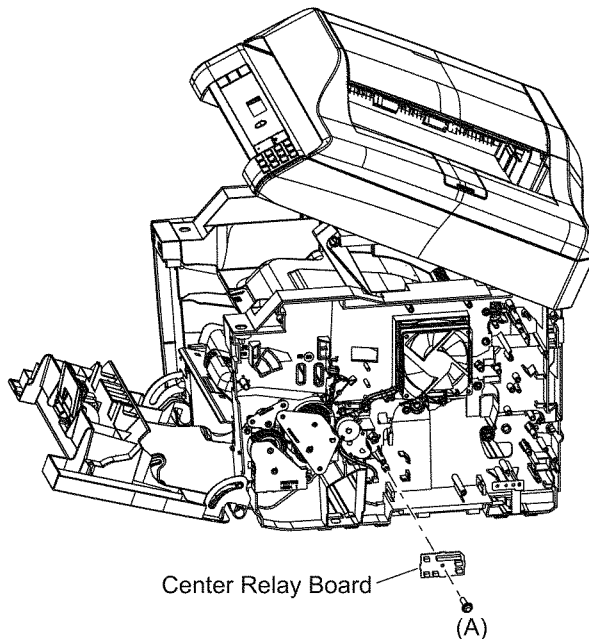
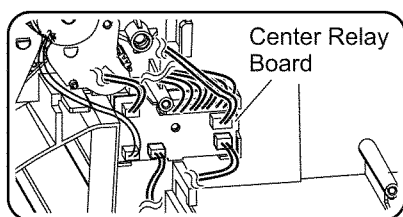

14.3.13. Remove the MPT Unit (MPT Relay Board)

K4

- 1) Remove the 2 screws (A) on the MPT Unit.
- 2) Remove the MPT Unit.
- 3) Remove the Connector on the MPT Relay Board.

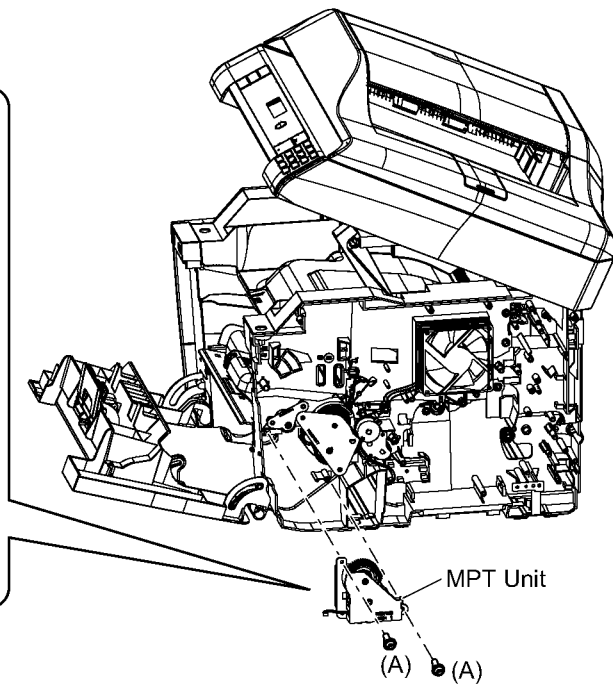
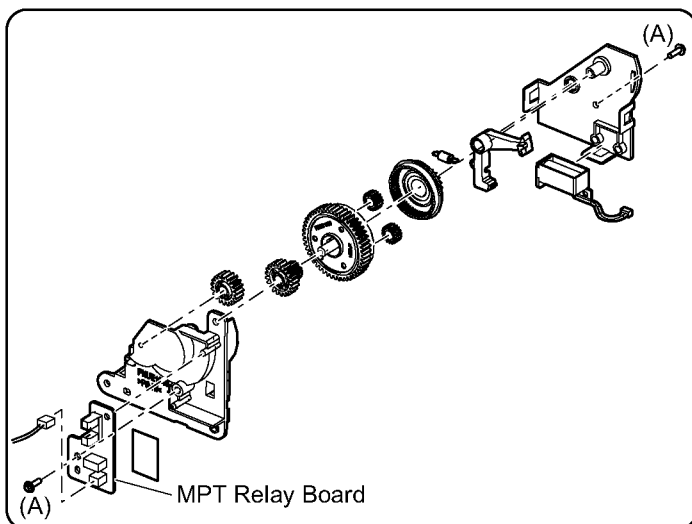

<Caution of assembly>

Detail of LEAD wire dressing (Refer to the 311pages)

14.3.14. Remove the FAN

K5

- 1) Remove the Connector on the Center Relay Board.
- 2) Remove the FAN.

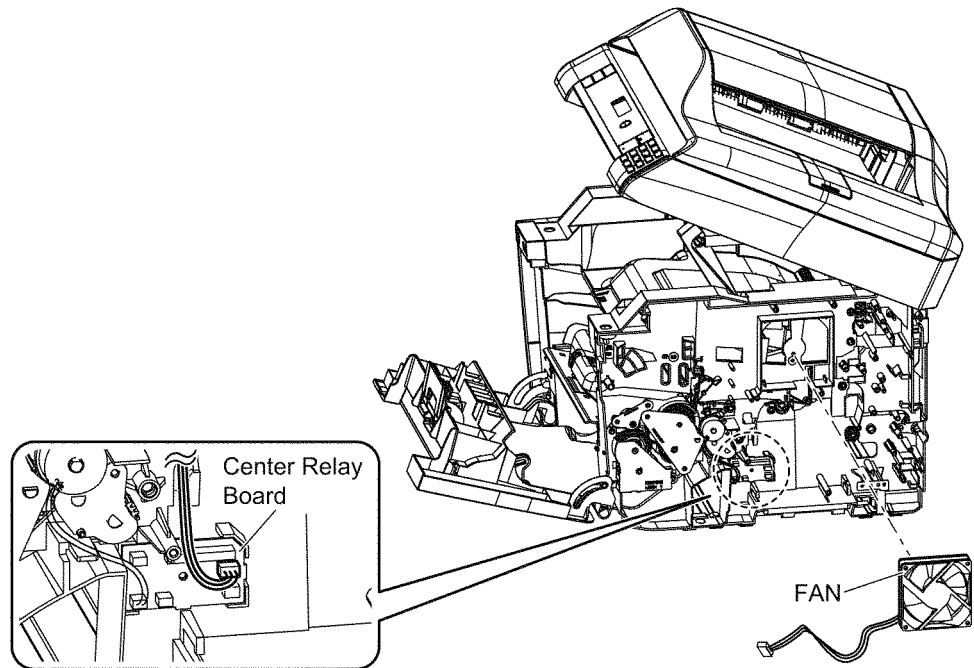

14.3.15. Remove the FB Unit

C1

- 1) A1: Remove the Left Cover
- 2) Remove the 3 Connectors and the Flat cable on the Main Board.
- 3) Remove the 1 screw (B) which holding 2 Earth Leads.
- 4) Release the spring from Hook (damper arm).

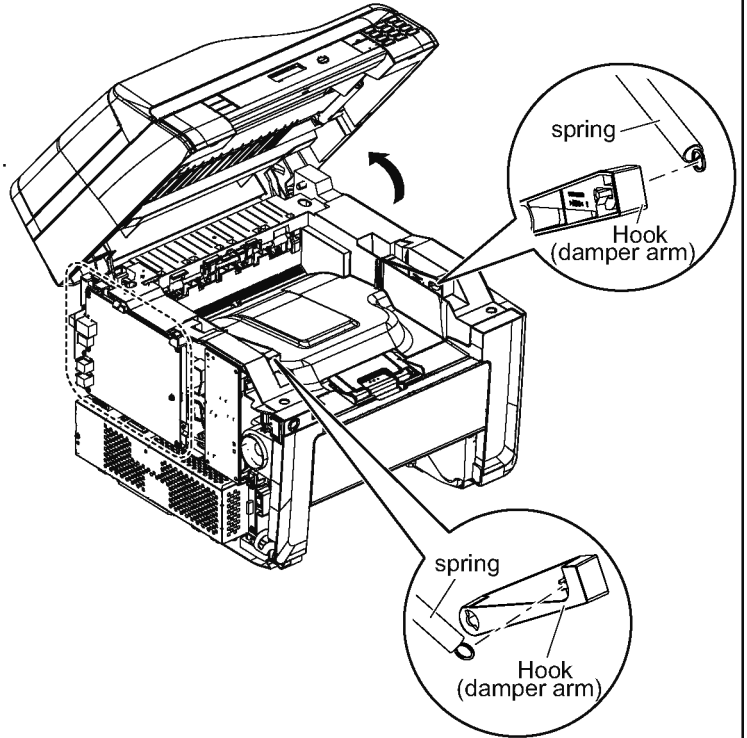
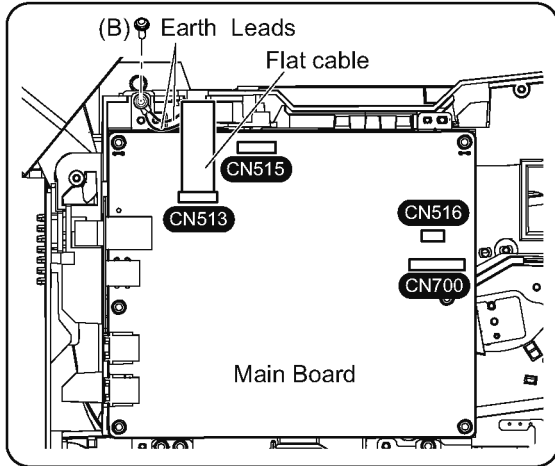

- 5) Remove the UL Tape (Black).
- 6) Angle the FB Unit 45 degrees.
- 7) Lift up the FB Unit.

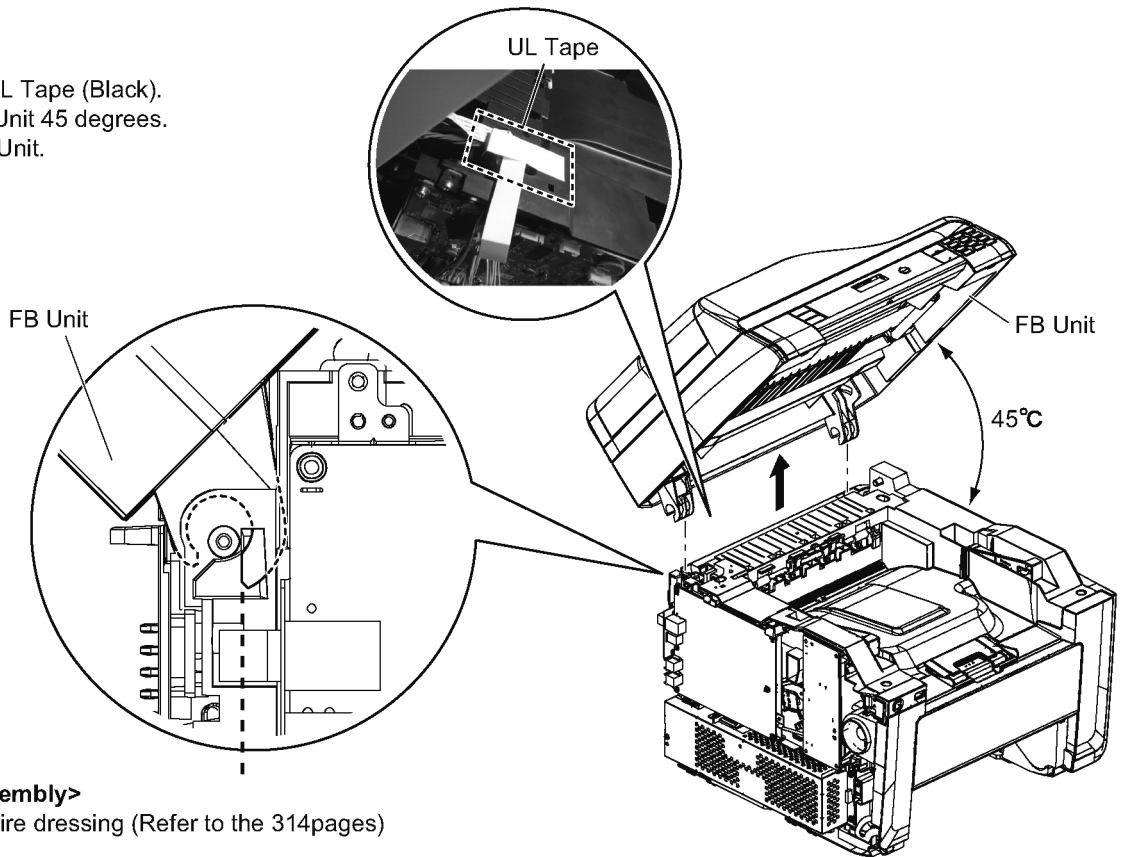

<Caution of assembly>
Detail of LEAD wire dressing (Refer to the 314pages)

14.3.16. Remove the Rear Door and Rear Cover

C2

- 1) Release the 2 Hooks of the Rear Door.
- 2) Remove the Rear Door.
- 3) Remove the 2 screws(A) on the Rear Cover.
- 4) There is the hook in the center.
Raise a little upwards and remove.
- 5) Remove the Rear Cover.

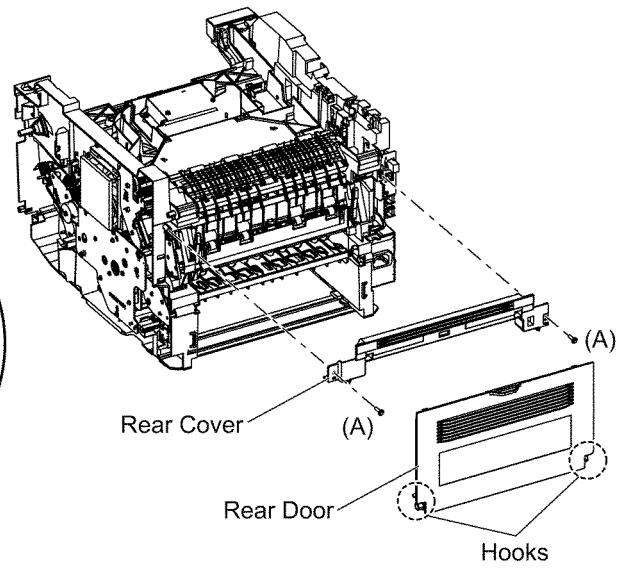
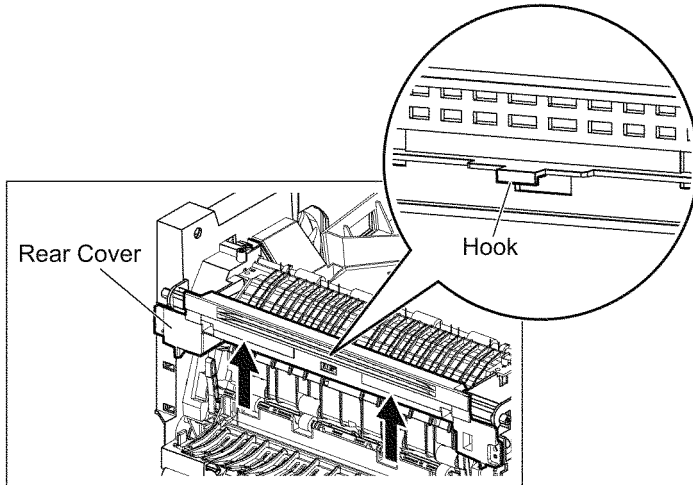

14.3.17. Remove the ADF Unit / ADF-Motor / ADF Relay Board

C3

- 1) Release the Stay Holder by sliding to left side.
- 2) Pull up the ADF Unit from the FB Unit.
- 3) Pull up and remove the ADF Unit from FB Unit by taking care of lead wires.

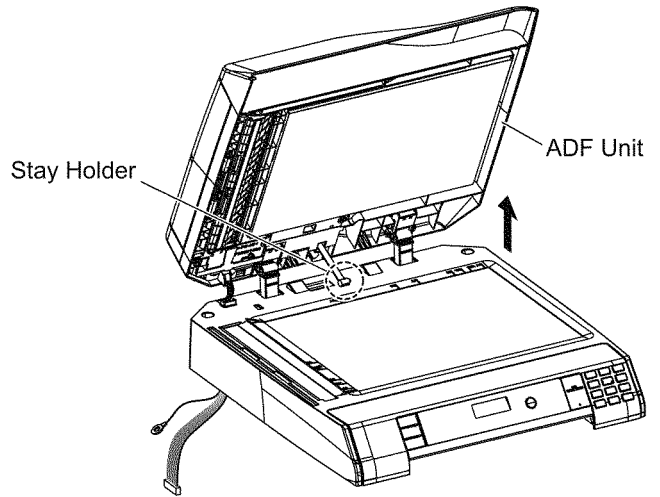

- 4) Release the 2 Hooks of the Paper Support ADF.
- 5) Remove the Paper Support ADF.

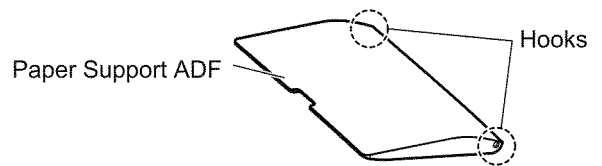

- 6) Release the 2 Hooks of the Separator ADF.
- 7) Remove the Separator ADF.

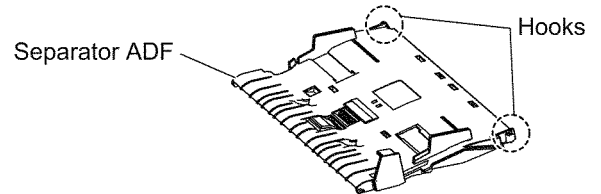

- 8) Release the 2 Hooks of the Cover-Top ADF.
- 9) Remove the Cover-Top ADF.

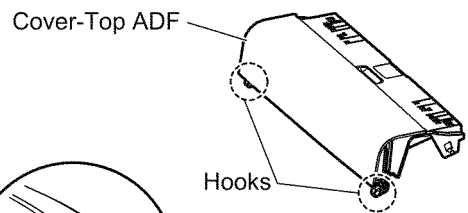

- 10) Remove the 2 screws (A1) of the Cover-Rear ADF.
- 11) Release the Hook of the Cover-Rear ADF.
- 12) Remove the Cover-Rear ADF.

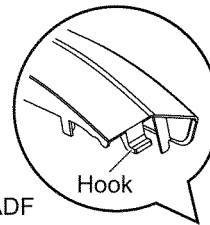

- 13) Remove the 4 screws (A2) of the Upper ADF.
- 14) Remove the Upper ADF.

- 15) Remove the 4 screws (A3) of the Switch Back ADF.
(Over side-3 screws, Under side-1screw)
- 16) Remove the Switch Back ADF.

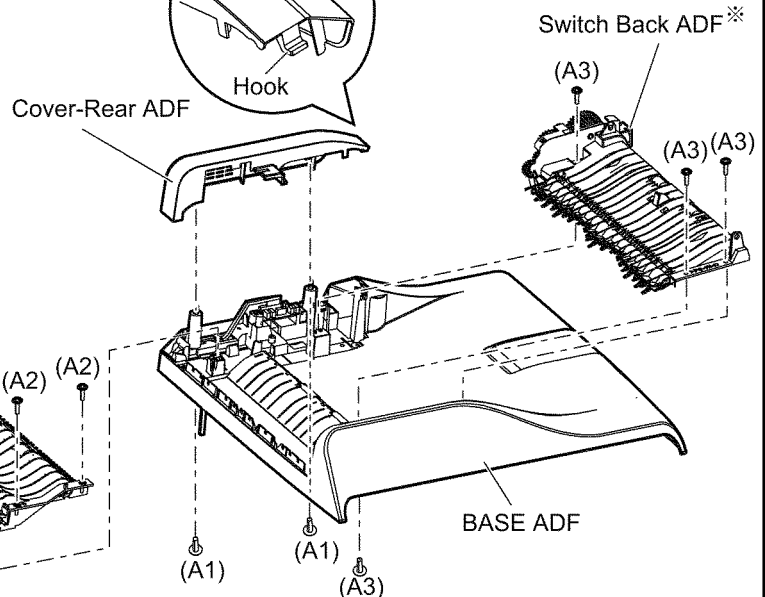

※In the case of the model with the Both Sides ADF function.

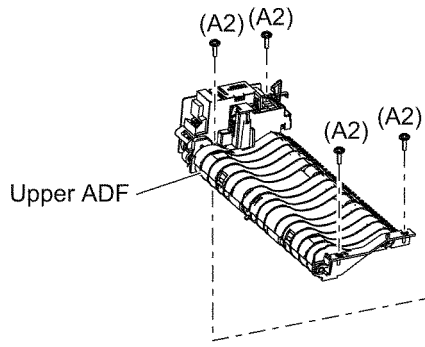

C3

※In the case of the model with the Single Sides ADF function.

- 1) Remove the screw (A) on the SADF Rear Frame.
- 2) Remove the SADF Rear Frame.
- 3) Remove the screw (A) on the SADF Front Frame.
- 4) Remove the SADF Front Frame.

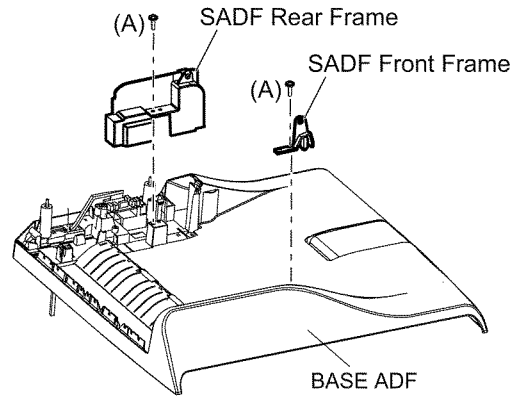

[Upper ADF - Motor ADF]

- 1) Remove the 4 screws (A) on the Motor ADF.
- 2) Remove the Motor ADF.

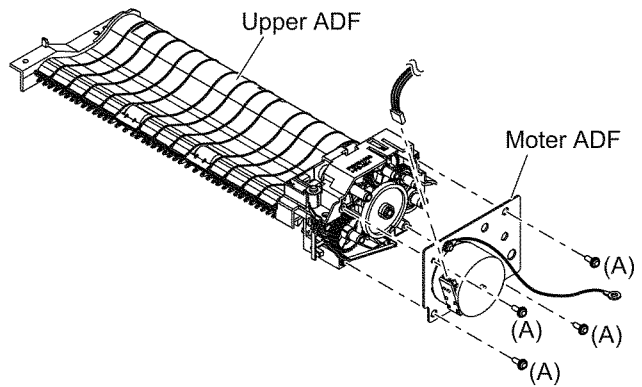

[Base ADF - ADF Relay Board]

- 1) Remove the ADF Relay Board by releasing the 2 hooks.

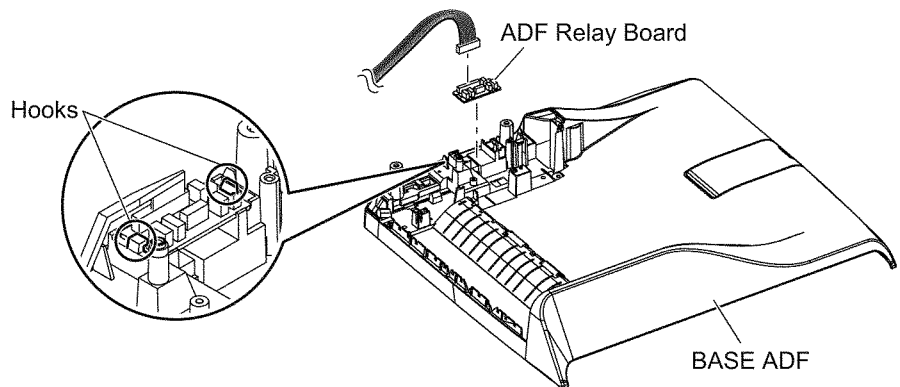

14.3.18. DOCU Sensor Board / RPS Board / RADF Board

H1

[Upper ADF - DOCU Sensor Board / RPS Board]

- 1) Remove the one screw (C) on the DOCU Sensor Board.
- 2) Remove the DOCU Sensor Board.
- 3) Remove the Connector on the DOCU Sensor Board.

- 4) Remove the 2 screws (A) on the Upper ADF_Bottom.

< Caution >

When you remove the Upper ADF_Bottom, be careful of loss of the 2 springs.

- 5) Separate the Upper ADF_Top and the Upper ADF_Bottom.
- 6) Remove the one screw (A) on the RPS Board.
- 7) Remove the RPS Board.
- 8) Remove the Connector on the RPS Board.

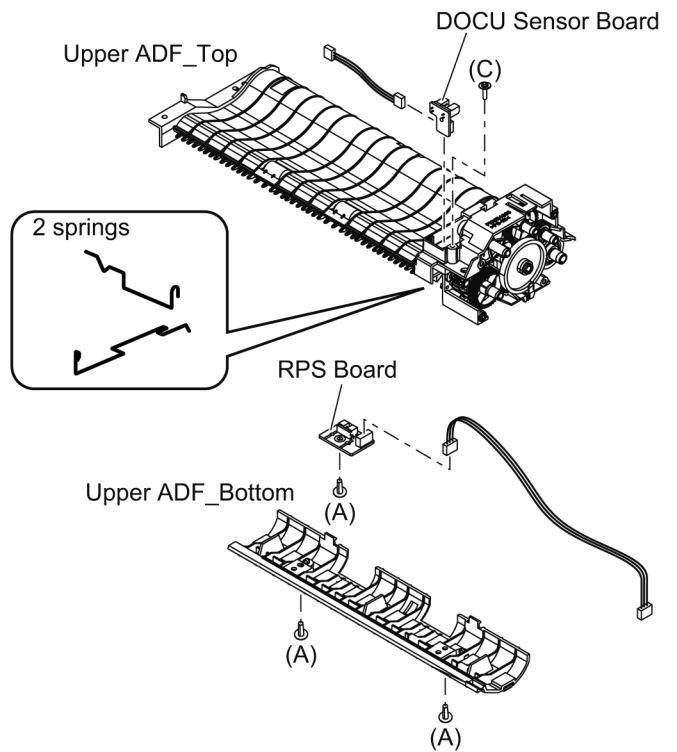

<Caution of assembly>

Detail of installing Spring

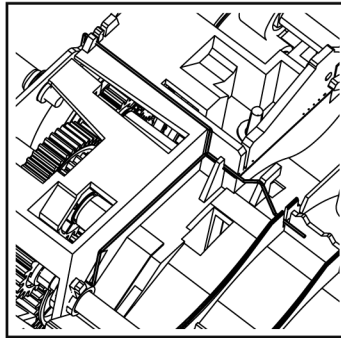
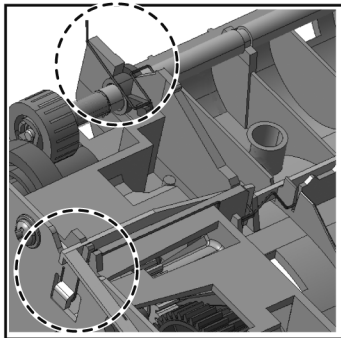

[Switch back ADF - RADF Board]

- 1) Remove the 2 screws (A) on the RADF Sensor Cover.
- 2) Remove the RADF Sensor Cover.
- 3) Remove the RADF Board.
- 4) Remove the Connector on the RADF Board.

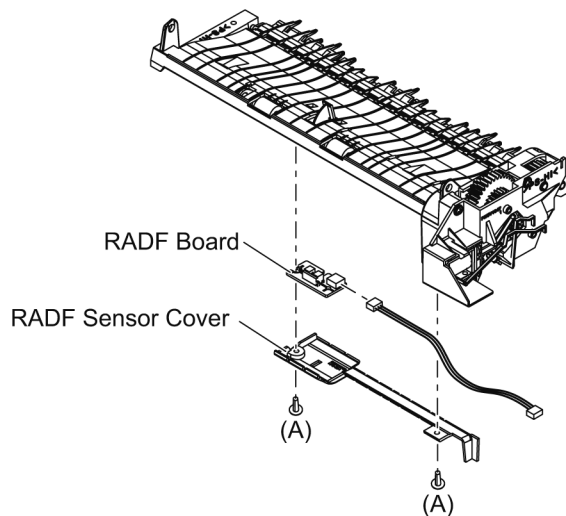

14.3.19. Disassemble the FB Unit (FB-Motor)

C4

[FB Motor]

- 1) Release the 7 Hooks from the FB Unit to remove the Operation Panel Assy..
- 2) Remove the one Connector from Operational Panel Board.
- 3) Remove the Operation Panel Assy..
- 4) Remove the 6 screws (A).
- 5) Separate the CASE-FB from the BASE-FB.
- 6) Remove the Assy. CIS from the Belt Timing.
- 7) Remove the Belt Timing.

< Caution >

When you remove the Belt Timing, be careful of loss of the Spring Belt.

- 8) Remove the 3 screws (A) on the FB-Motor.
- 9) Remove the FB-Motor.

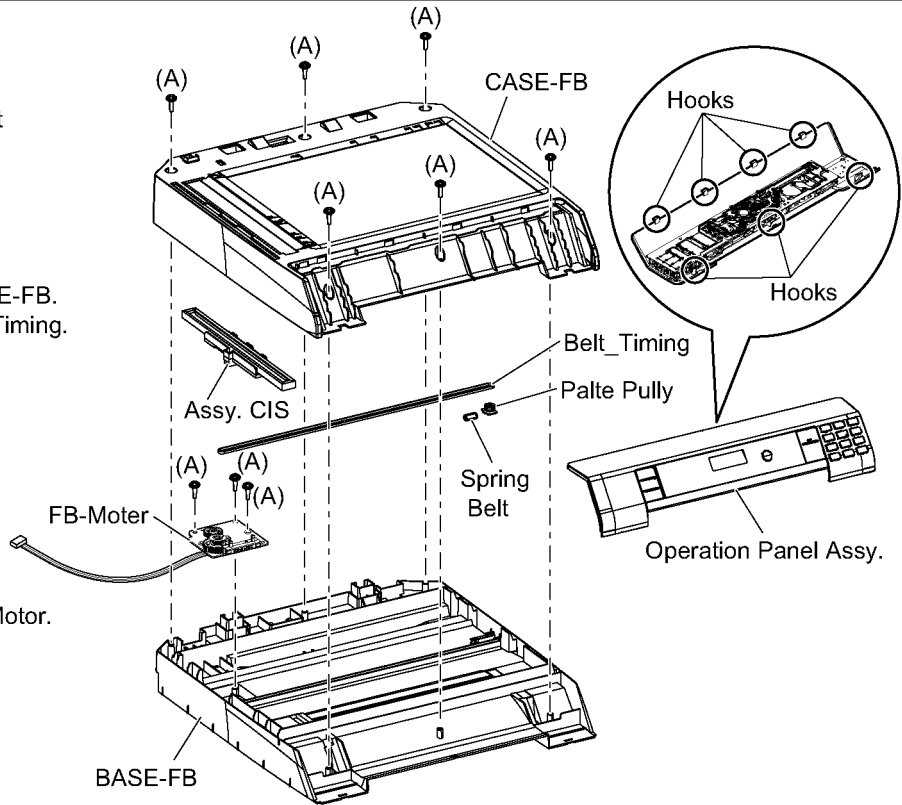

<Caution of assembly>

Detail of LEAD wire of FB-Motor dressing (Refer to the 313pages)

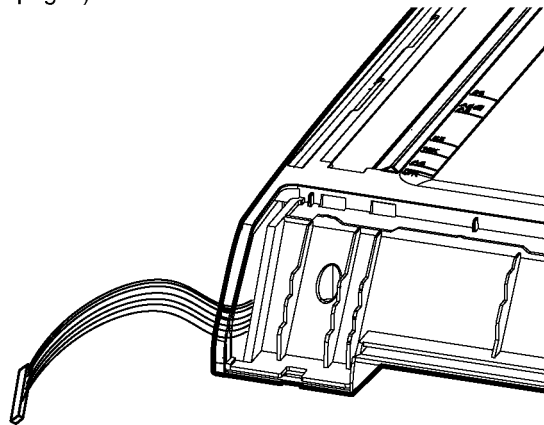

14.3.20. Disassemble the Operation Panel Assy

J1

In the case of the model with the One Touch Key function

- 1) Remove the one screw (A) on the Operation Panel.
*In the case of the model with the One Touch Key function has 2 screws(A).
- 2) Remove the Operation Panel Board.

< Caution >

When you remove the Operation Panel Board, be careful of 2 hooks.

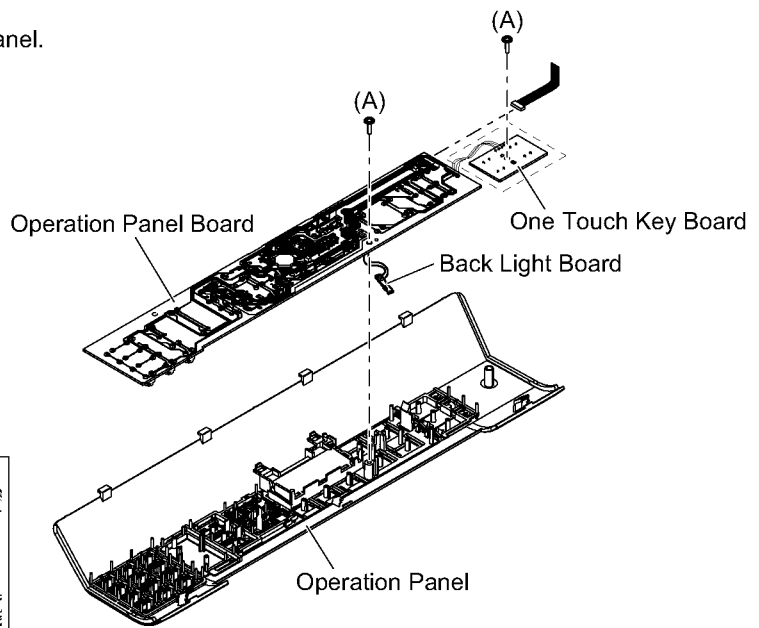
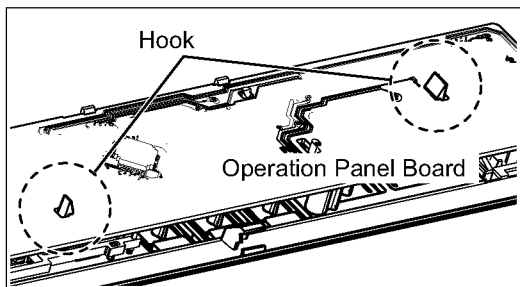

14.3.21. Remove the Fuser Unit (Fuser Board)

D1

- 1) To release the Guide,
Pull the center of the Guide by figure.(Fig1)
- 2) Release connection of the connector.(Fig2)
- 3) Remove the 3 screws(E) on the Fuser Unit.
- 4) Remove the Fuser Unit.
- 5) Remove the Connector on the Fuser Board.
- 6) Remove the one screw(A) on the Fuser Board.
- 7) Remove the Fuser Board.

*Some model has this kind of connector, But other model do not have. (direct connected to SMPS Board)

(Fig1)

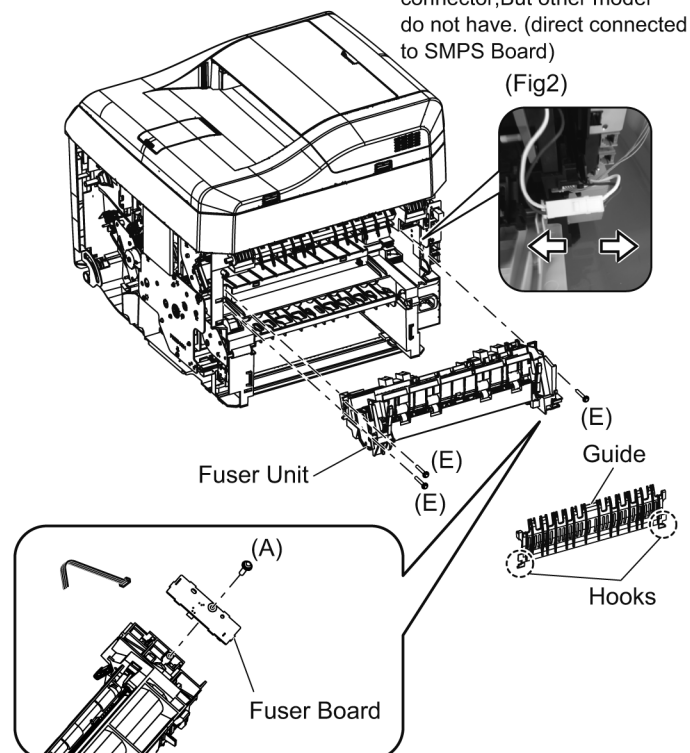
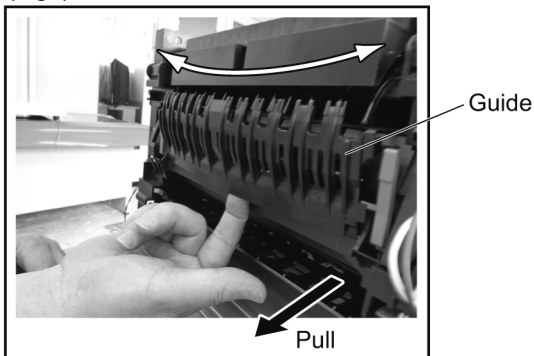

14.3.22. Remove the Top Cover

E1

- 1) Remove the 5 screws(A) on the Top Cover.
- 2) Lift up the Top Cover by paying attention to the "Earth Spring" below.

< Caution >

When you lift up the Top Cover, be careful of loss of the Earth spring.

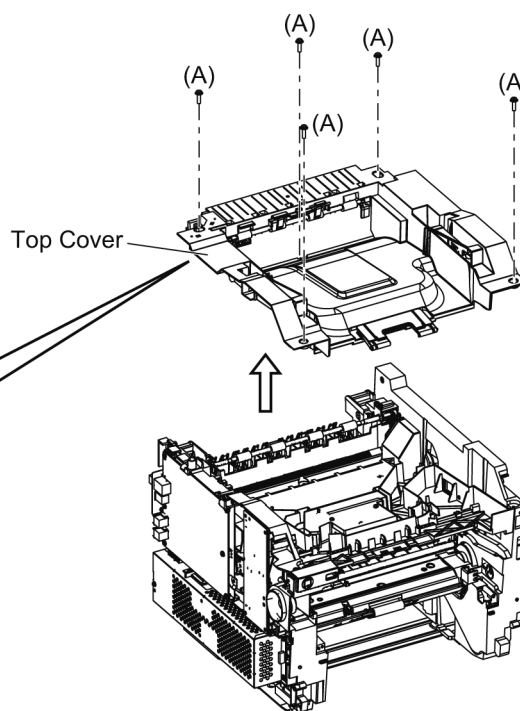
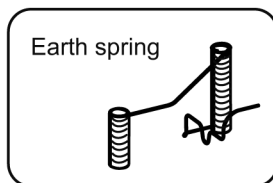

<Caution of assembly>

Detail of install the Top Cover

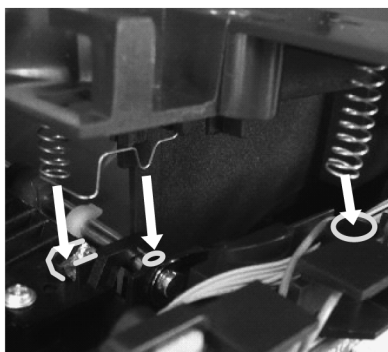
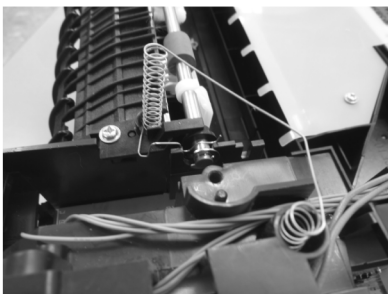

Confirm the spring condition (contact point) after assembly

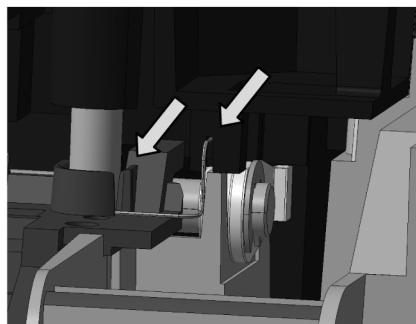

Detail of install the Top Cover

Fixing screw sequence

①→②→③→④→⑤

Keeping the order of tightening screws.

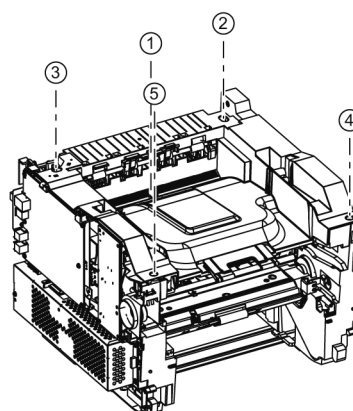

14.3.23. Remove the Main Chassis

L1

How to remove the LSU / Antenna(H) Board

- 1) Remove the UL Tape on the Main Chassis.
 - 2) Remove the Antenna(H) Board on the LSU Unit.
- ※In the case of the model with the Wi-Fi function.

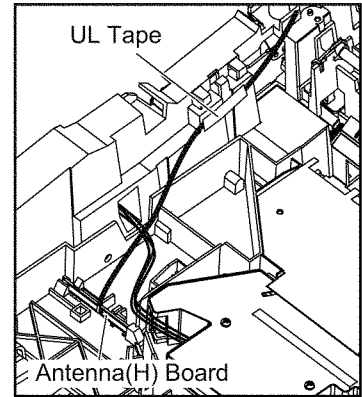

Even if it does not remove the LSU Stay, it separates from it.

- 3) Remove the 2 screws(A) on the LSU Cover.
- 4) Remove the LSU Cover.
- 5) Pull all Connectors of the LSU out of the Main Chassis.
- 6) Remove the 3 screws(A) on the LSU Unit.
- 7) Remove the LSU.

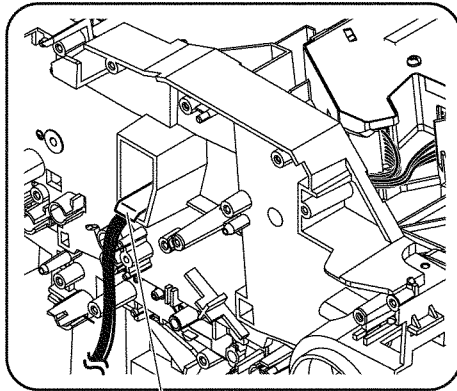

TAPE length 50mm(+5)

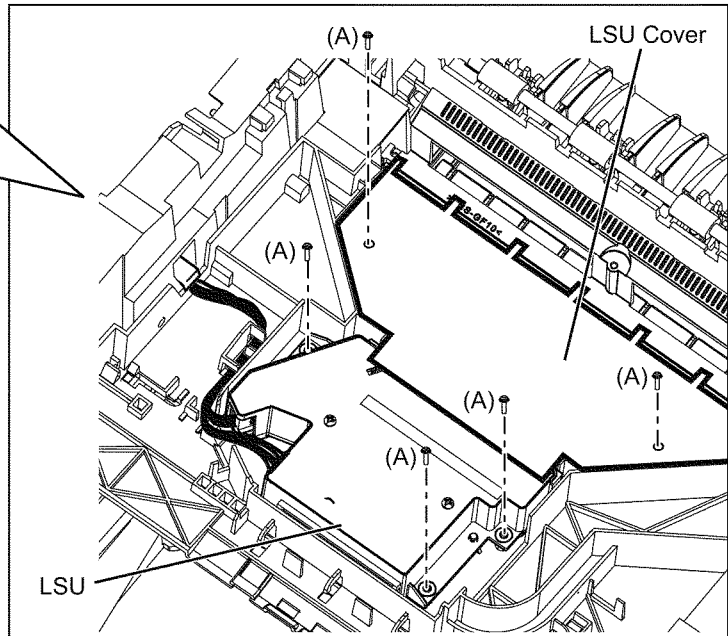

<Caution>

- Wear Earth Band when handling the LSU.
- Do not touch the surface of the lens.

<Caution of assembly>

Detail of installing the LSU
Attachment order of screws

- ①→②→③

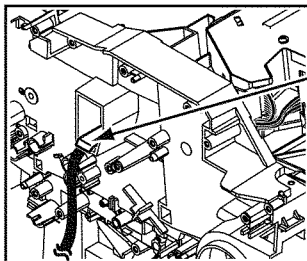

The course of a LEAD/LASER and LEAD/POLYGON

Securely attached to the main chassis

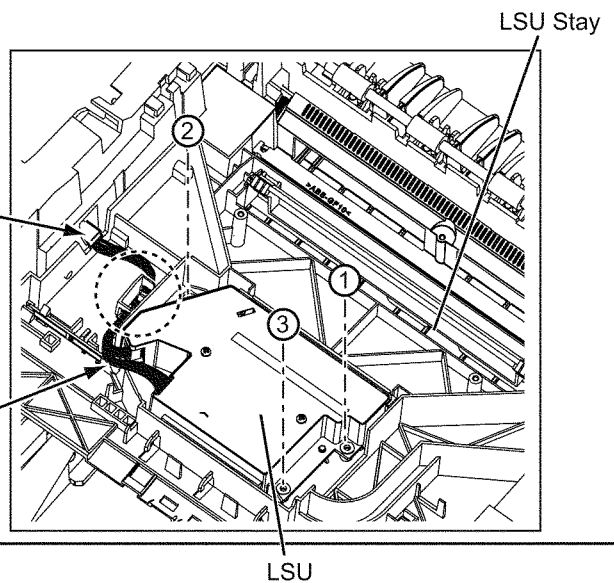

L1

How to remove the Power Switch Unit

- 1) Remove the screw(A) on the Power Switch Unit.
- 2) Remove the 2 Connectors on the Main Board.
- 3) Remove the Power Switch Unit.
- 4) Remove the screw(A) on the Power Switch Board.
- 5) Remove the 2 Connectors on the Power Switch Board.

*There is a model which USB function does not attach.

The position of the connector to remove

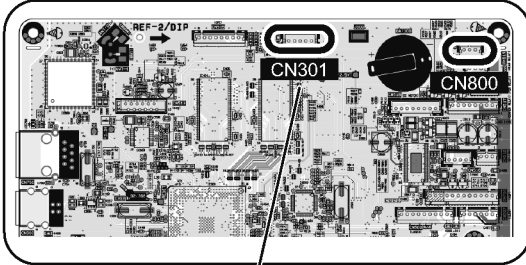

USB connector

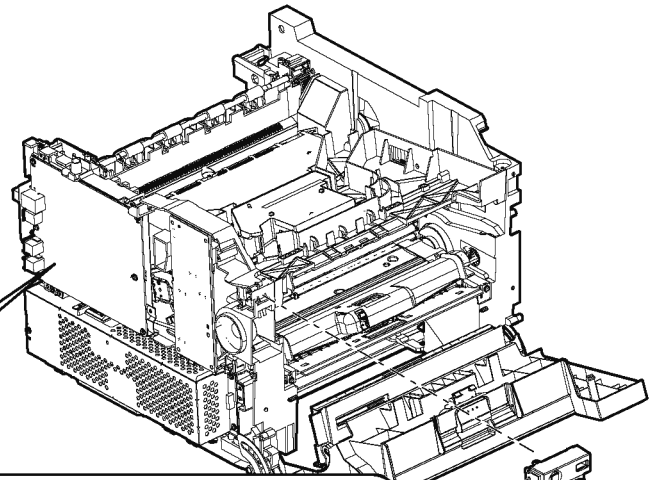
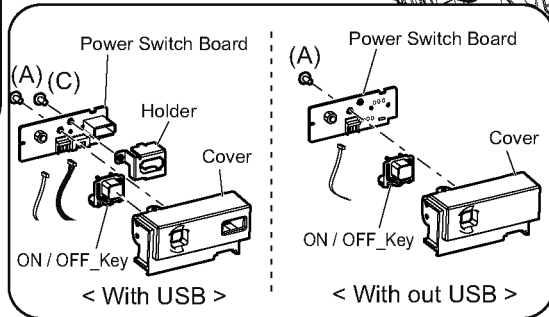

Power Switch Unit

How to remove the LSU Stay

- 6) Remove the 6 screws(A) of both sides.
- 7) Remove the LSU Stay.

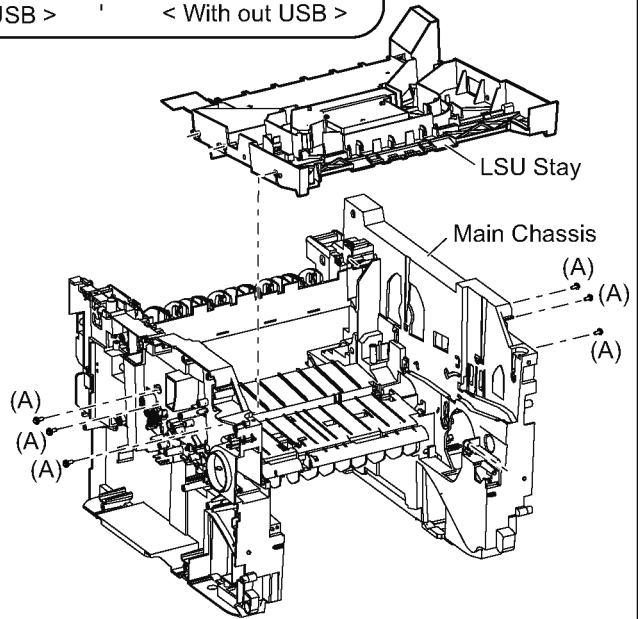
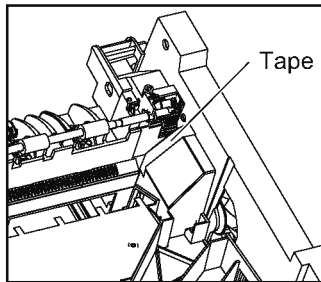

LSU Stay

Main Chassis

<Caution of assembly>

Detail of installing LSU Stay

Fixing screw sequence ①→②→③
There is no order
right side first or left side first.

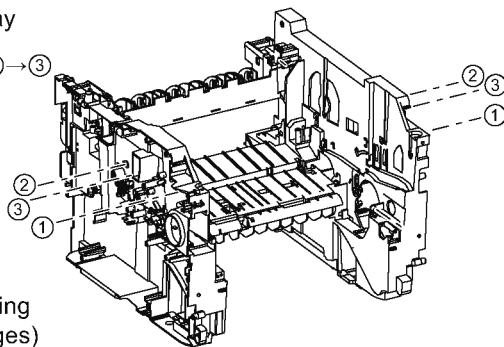

Detail of LEAD wire dressing
(Refer to the 310pages)

Detail of installing VOC Filter

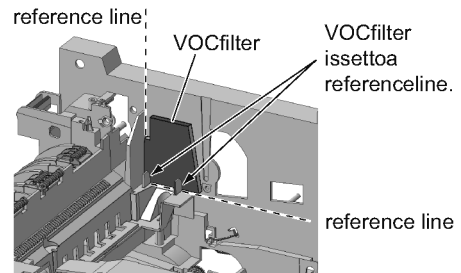

L1

How to remove the ADU Unit

- 1) Push the release button and remove the latch of ADU Unit.
- 2) Push down ADU Unit aslant and pull it out.
- 3) Remove the ADU Unit.

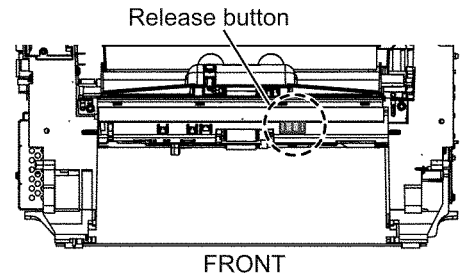

<Caution of disassembly / assembly >

- ※The fulcrum parts is lowered downward and it draws out from the hole.
- ※The fulcrum parts is caught when passing by the hole, Be careful.

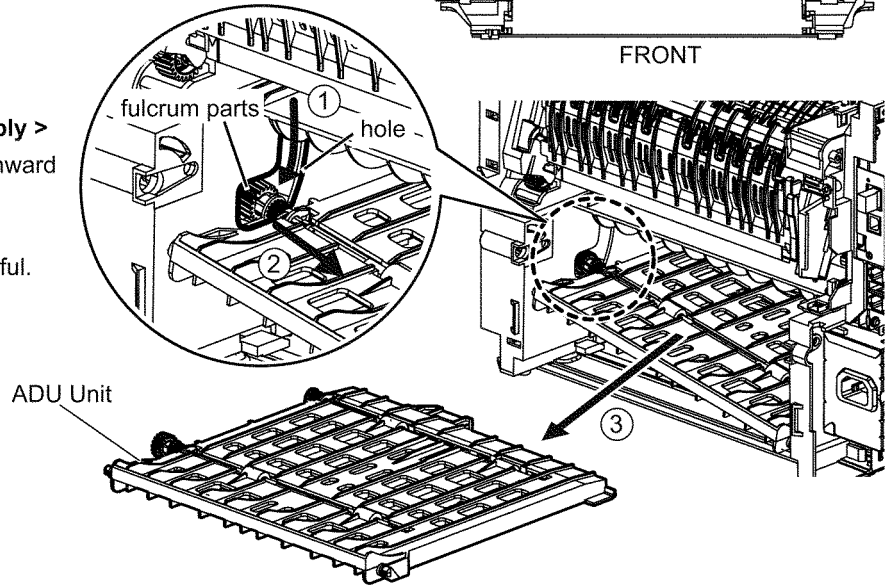

How to remove the Pick Up Block

- 1) Remove the Washer on the MPT-Rick-Plate of the Right side.
- 2) Remove the 2 screws(A) on the MPT-Rick -Plate.
- 3) Remove the Earth Lead.
- 4) Remove the MPT-Rick-Plate.

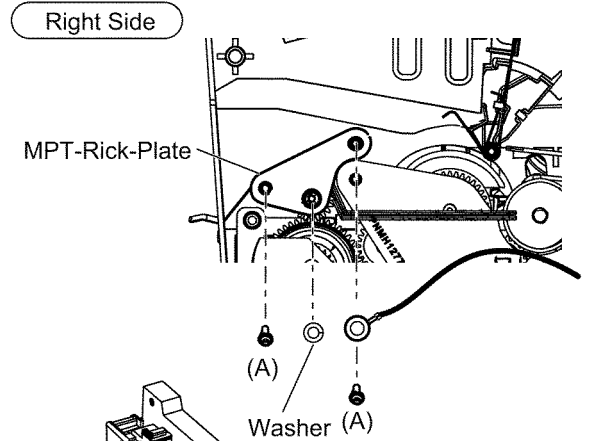

- 5) Remove the 2 screws(A) of the Front side.
- 6) Remove the Pick Up Block.

- ※Remove drawing out the Pick Up Block from the hole.
- ※The Gear is caught when passing by the hole, Be careful.

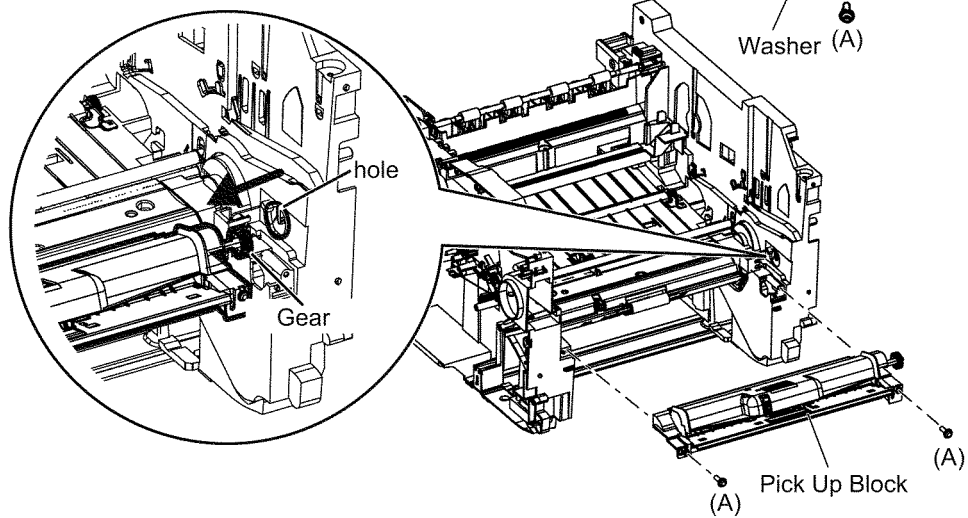

L1

How to remove the Paper Feed Unit

- 1) Remove the Washer on the Feed-Gear-Plate of the Right side.
- 2) Remove the 2 screws(A) on the Feed-Gear-Plate.
- 3) Remove the Feed-Gear-Plate.
- 4) Remove the Connector on the Center Relay Board (Right side).

* The lead of the Center Relay Board is short.

The position of the connector to remove

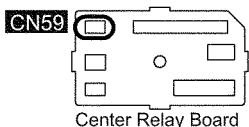

- 5) Remove the 2 screws(A) of the Front side.
- 6) Remove the Paper Feed Unit.

a) Remove drawing out a little the Paper Feed Unit from the hole.

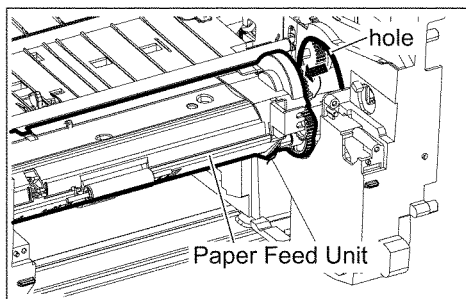

b) Pass the Connector and Earth Lead into the connector hole.

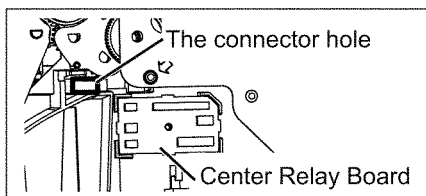

c) Pull out the Paper Feed Unit.

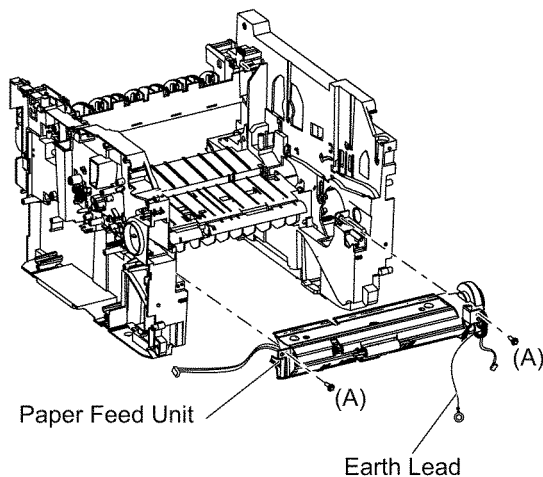
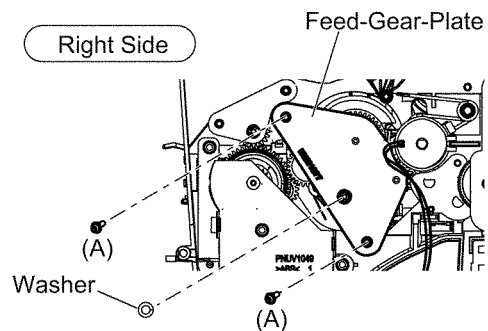

<Caution of assembly _ Paper Feed Unit >

- a) Pull out the connector and Earth Lead from the connector hole.
- b) Take care not to make the lead wires slack.
- c) Insert Paper Feed Unit in the hole.
※The Gears are caught when passing by the hole, Be careful.

- 7) Remove the 3 screws(A).
- 8) Separate the Guide-Cover from the Guide-Base.
- 9) Remove the Lever and Connector on the Pick Up Relay Board.
- 10) Remove the Pick Up Relay Board.

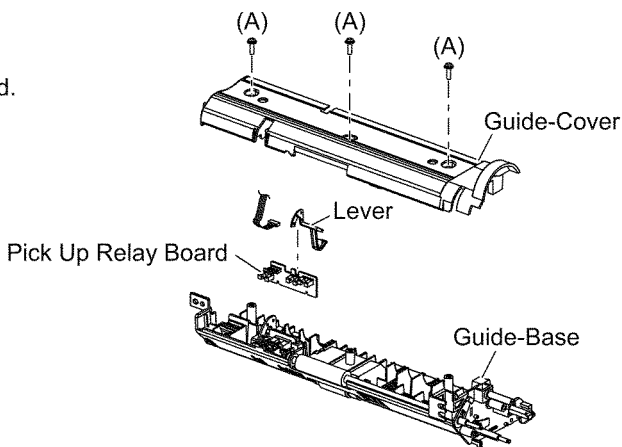

L1**How to remove the Rear Sensor Board**

- 1) Release the Leads twisted of the Main Chassis side.
- 2) Remove the one screw(A) on the Rear Sensor Board.
- 3) Pull up the Rear Sensor Board.
- 4) Remove the Connector.

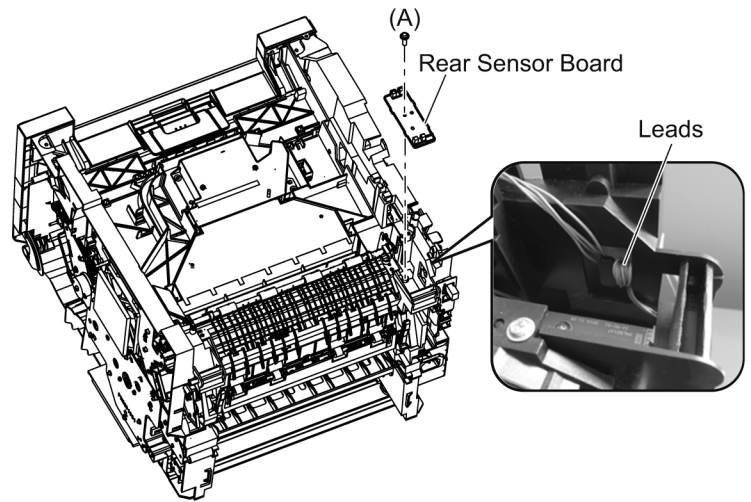

14.4. Installation Position of The Lead

14.4.1. Main Cabinet Section

Detail of installing the LSU Unit

Attachment order of screws

①→②→③

TAPE length 50mm(+/-5)

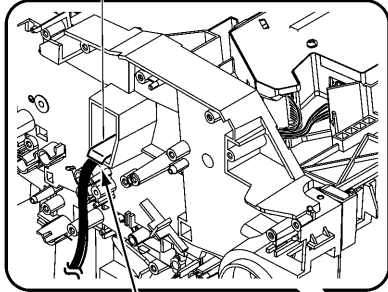

Securely attached
to the main chassis

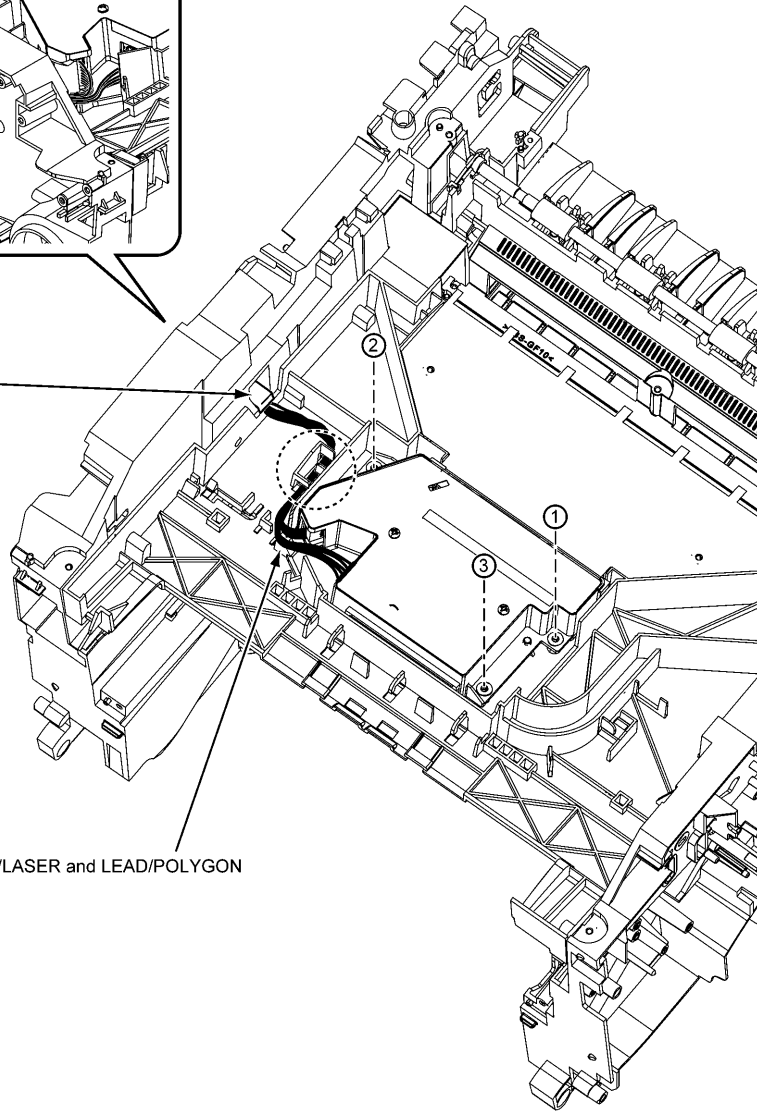

The course of a LEAD/LASER and LEAD/POLYGON

14.4.2. Wire dressing on the Left Side Section(Main Board)(1)

Pass the Lead through the main chassis boss.

Core can not be placed on the PCB.



- *USB Connector is inserted after assemble ADF.
- *Do not contact Lead of USB and Lead of ADF RELAY.

< FG Lead terminal direction >

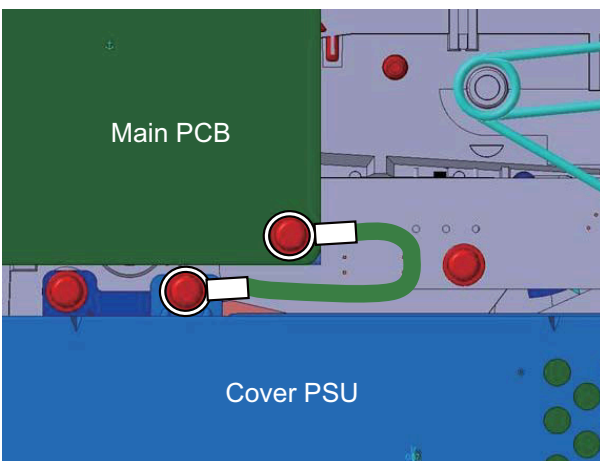

< Core attachment to LEAD of DC Motor >

Pass through 3 times, wind 2 times to core.

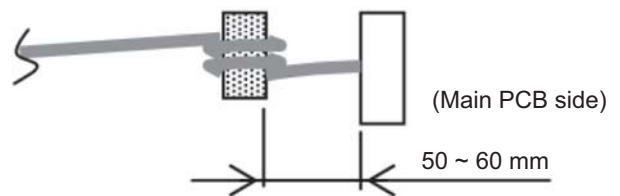

14.4.3. Wire dressing on the Left Side Section(Main Board)(2)

Detail of UNIT/ANTENNA and Antenna Board soldering

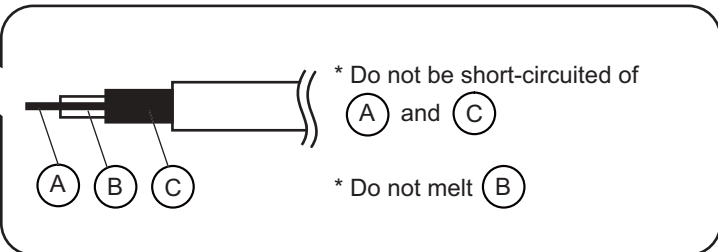
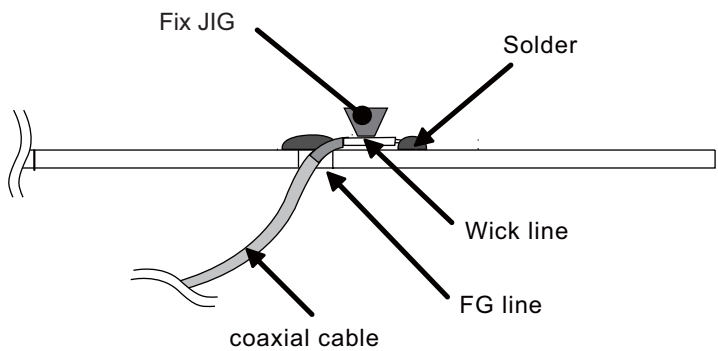
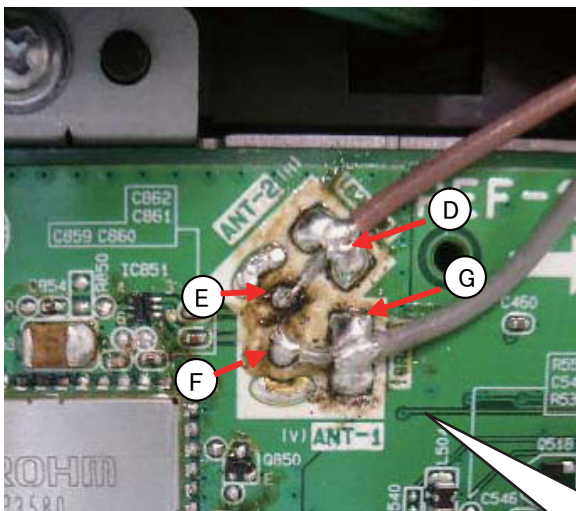
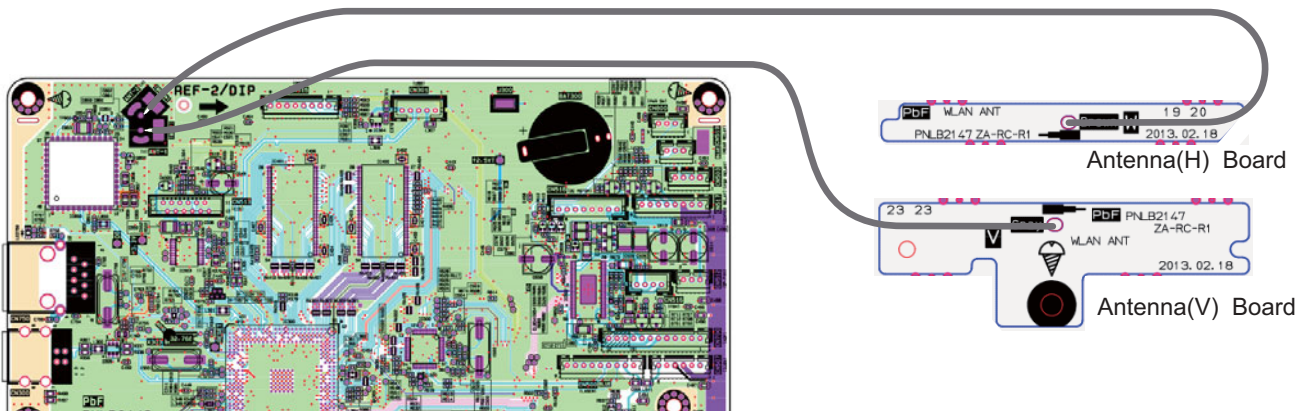

- a) Use lead free wire solder.
- b) Use the soldering Jig supplied by P.E.
- c) It should be control with Temperature and duration time : $370^{\circ}\text{C} \pm 10^{\circ}\text{C}$, within 3 sec.

After the soldering, check continuity by teseter.

(1) Check open following point. (Open:OK)

1) (D) — (E)

14.4.4. Wire dressing on the Left Side Section(Main Board) (3)

Detail of Antenna(V,H) LEAD wire dressing

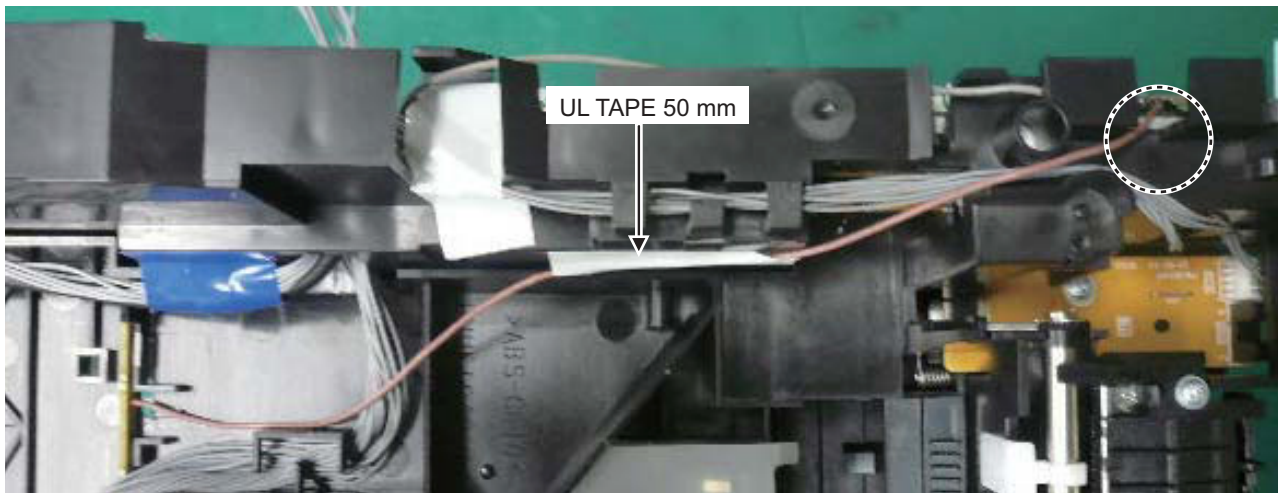
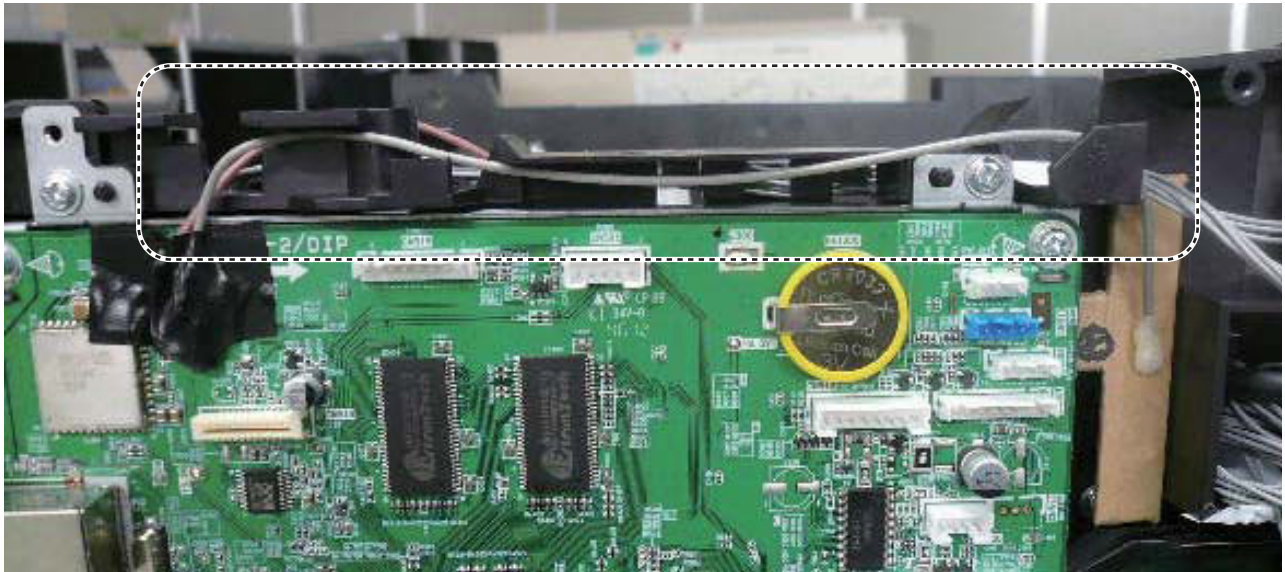

Details of LEARD Taping

Wire dressing along the line of the STAY LSU.

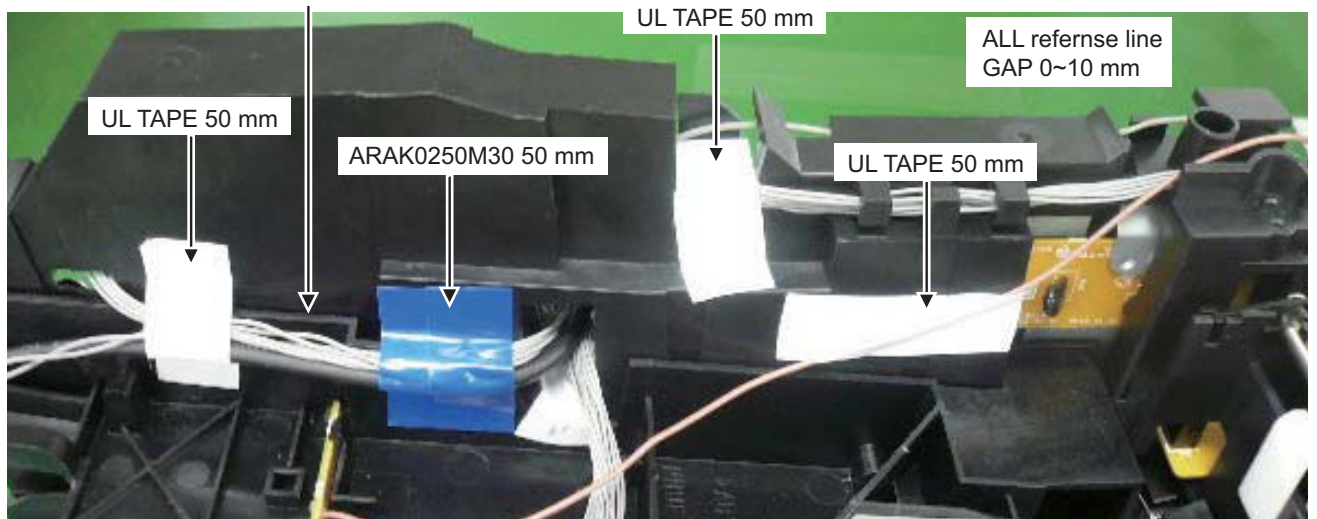

14.4.5. Wire dressing on the Left Side Section(Main Board) (4)

Detail of LEAD of DC Motor and LEAD of Center Relay dressing

Lead hooking in the main chassis like this figure.

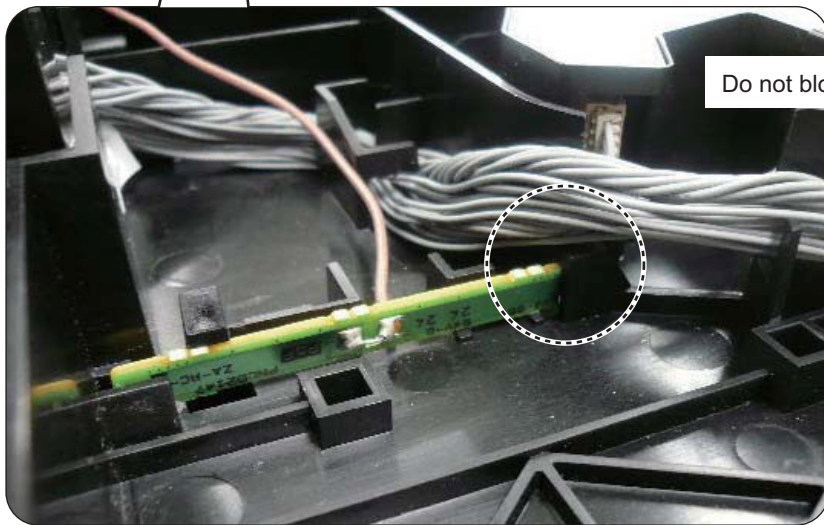

14.4.6. Wire dressing on the Right Side Section (1)

*Pass the LEAD of MPT Unit and LEAD of Clutch through the main chassis groove and boss.

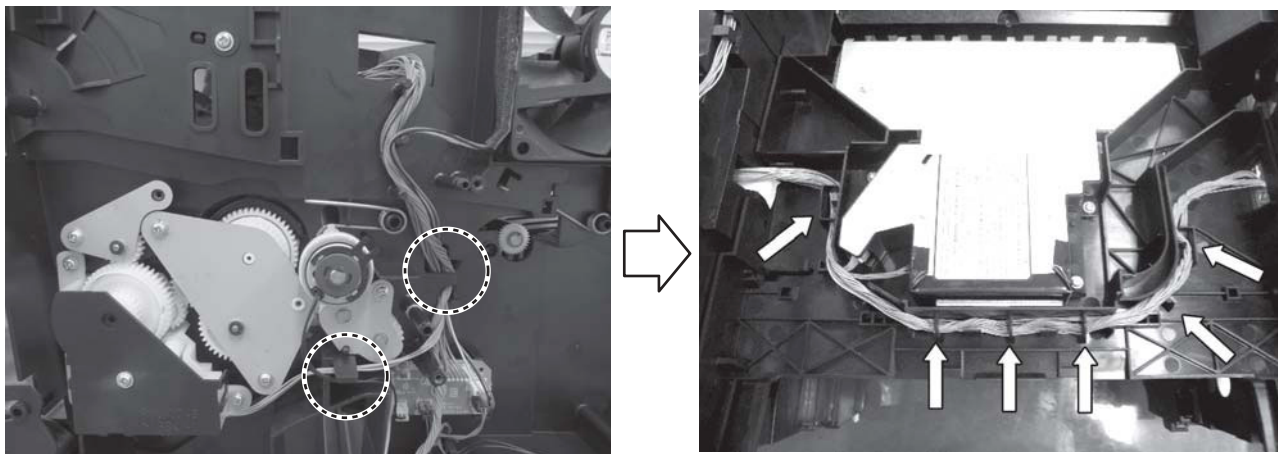

*Pass the LEAD of FAN through the main chassis boss. (2 points)

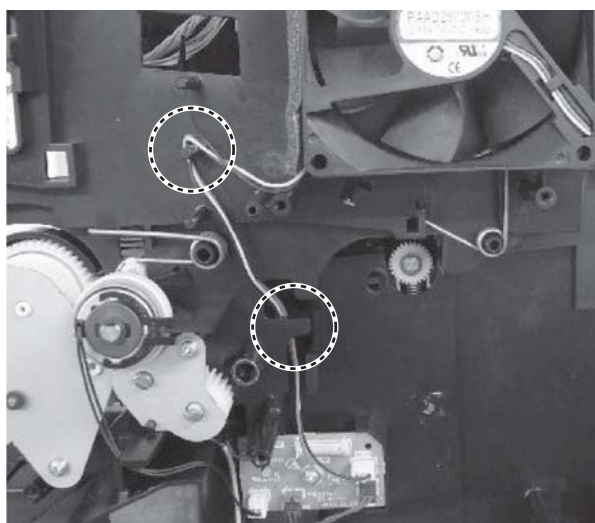

*Pass the LEAD of DC Motor through the main chassis boss. (4 points)

*LEAD of DC Motor wire length is adjusted to 80 mm From the lowest boss.

*Core attachment to LEAD of DC Motor.(Wind 2 times)

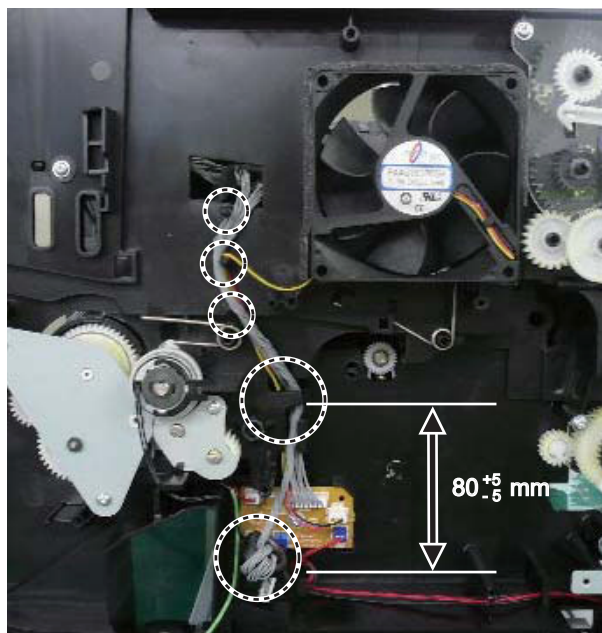
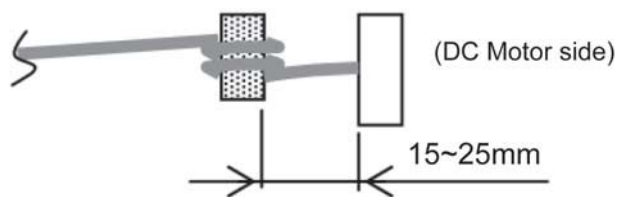

14.4.7. Wire dressing on the Right Side Section (2)

Detail of SOLENOID LEAD wire dressing

*Pass the LEAD through the main chassis boss and rib.

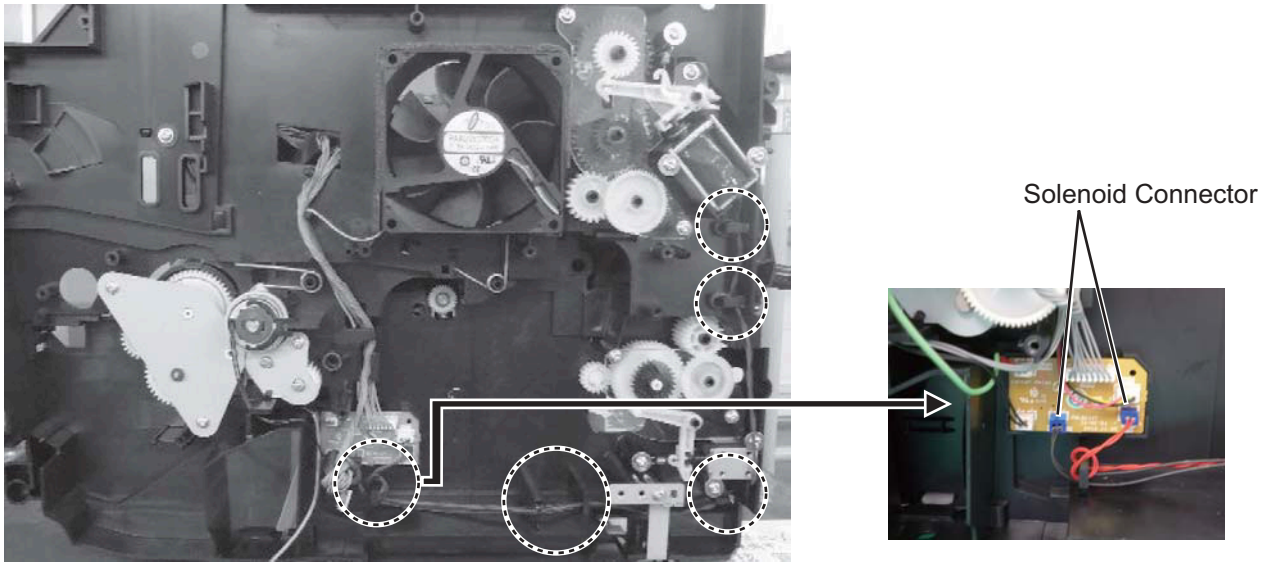

Detail of FUSER LEAD wire dressing

Pass the LEAD through the main chassis boss and rib.

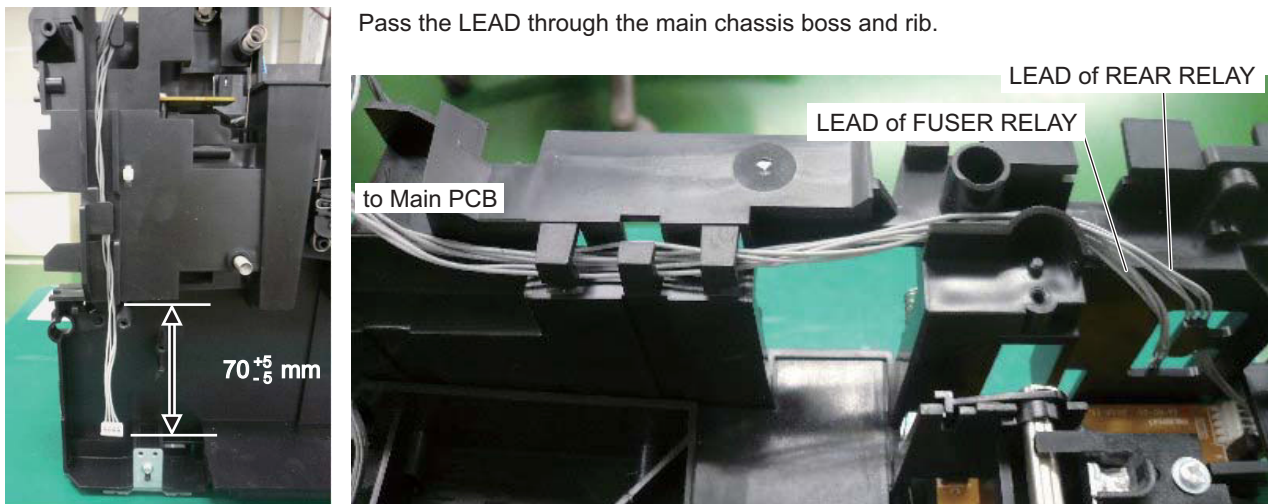

14.4.8. FB Unit (1)

OK

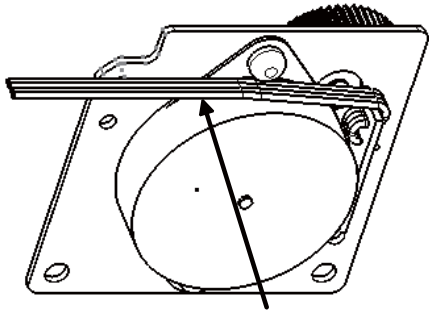

Route the motor harness along the side face of motor.

NG

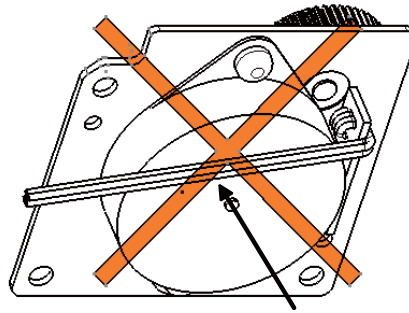

Do not come out the motor harness to the bottom face of motor.

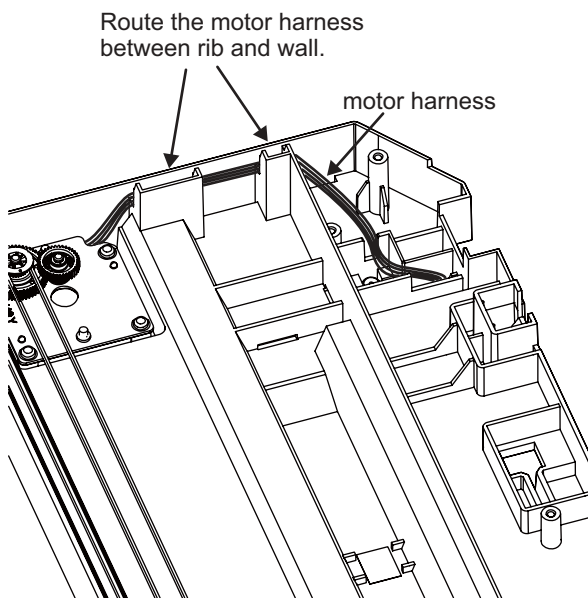

Route the motor harness between rib and wall.

motor harness

14.4.9. FB Unit (2)

Detail of wire dressing SCANNER UNIT

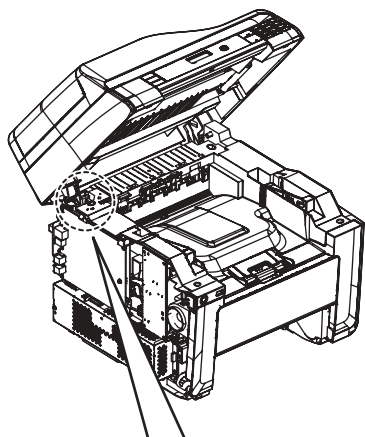

Dressing LEAD wire and LEAD FG first.

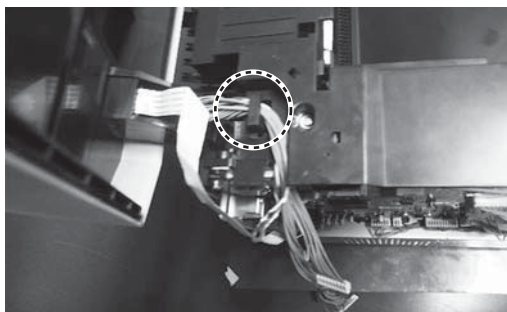

Dressing FFC last.

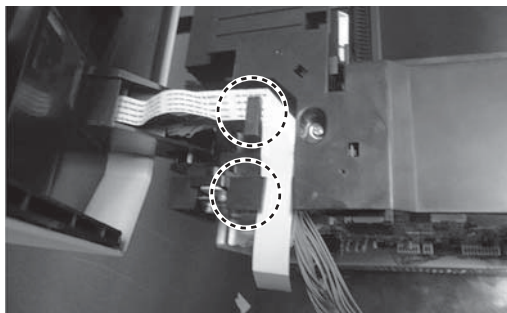

Paste TOP/COVER rib.

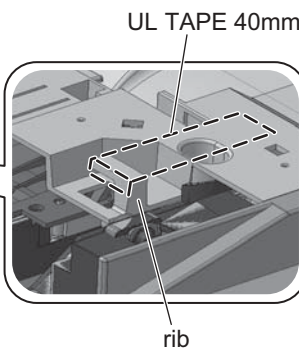
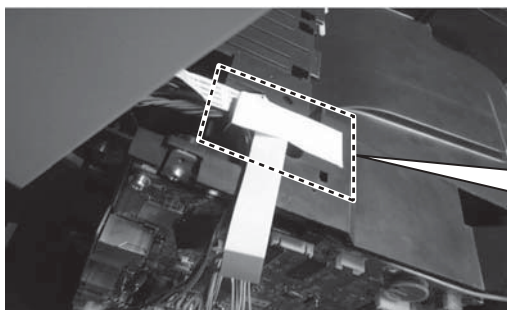

14.4.10. Fuser Lead

Fuser Lead

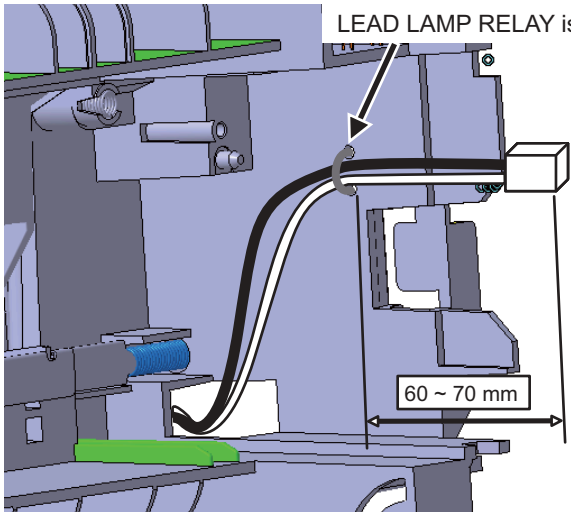

<CONFIRMATION> FUSER LEAD do not interfere with sensor lever.

Sensor Lever

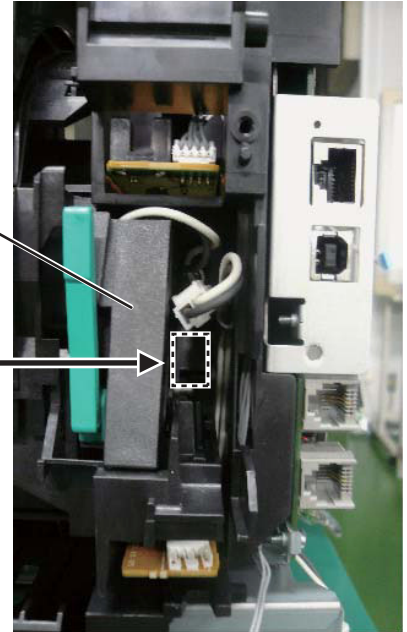

15 Maintenance

15.1. Maintenance Items and Component Locations

15.1.1. Outline

MAINTENANCE AND REPAIRS ARE PERFORMED USING THE FOLLOWING STEPS.

1. Periodic maintenance

Inspect the equipment periodically and if necessary, clean any contaminated parts.

2. Check for breakdowns

Look for problems and consider how they arose.

If the equipment can be still used, perform copying, self testing or communication testing.

3. Check equipment

Perform copying, self testing and communication testing to determine if the problem originates from the transmitter, receiver or the telephone line.

4. Determine causes

Determine the causes of the equipment problem by troubleshooting.

5. Equipment repairs

Repair or replace the defective parts and take appropriate measures at this stage to ensure that the problem will not recur.

6. Confirm normal operation of the equipment

After completing the repairs, conduct copying, self testing and communication testing to confirm that the equipment operates normally.

7. Record keeping

Make a record of the measures taken to rectify the problem for future reference.

15.1.2. Maintenance Check Items/Component Locations

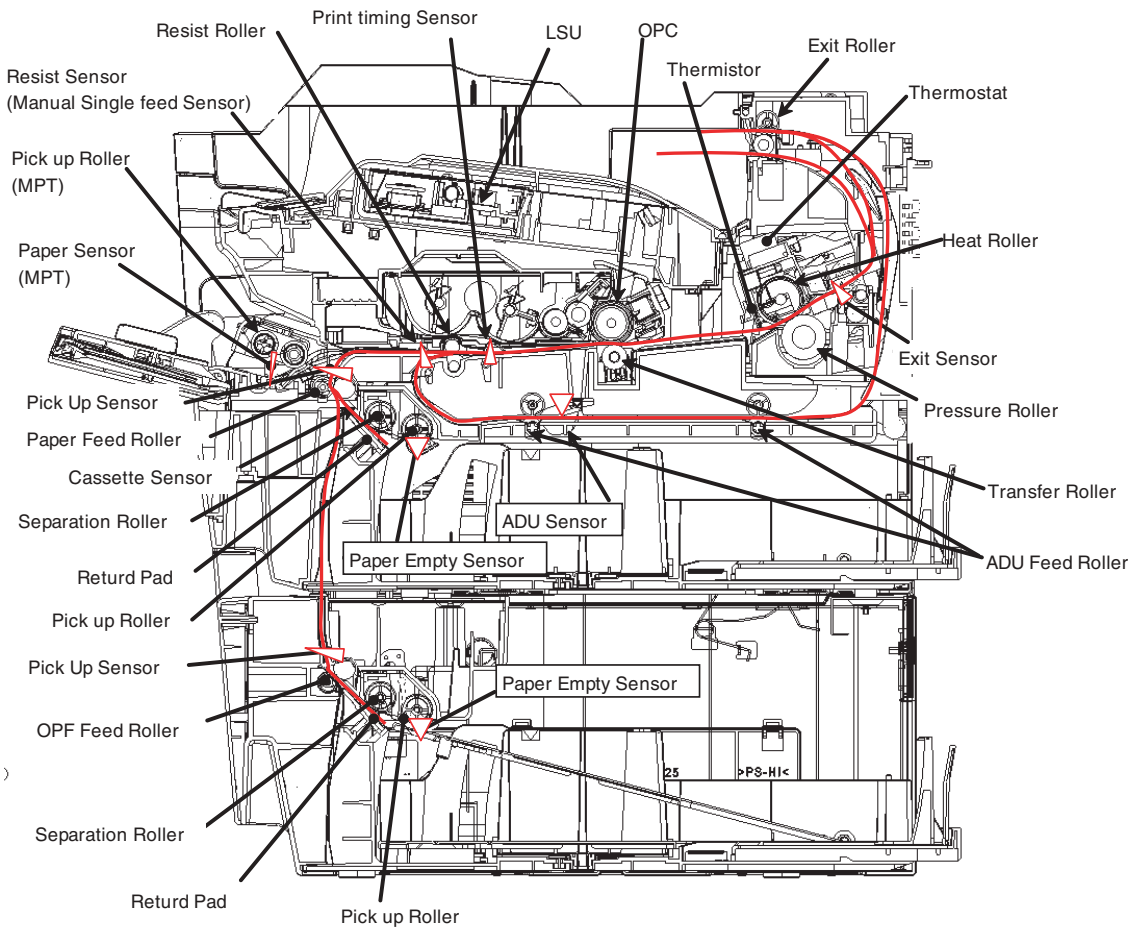

15.1.2.1. Maintenance List

NO.	OPERATION	CHECK	REMARKS
1	Document Path	Remove any foreign matter such as paper.	—
2	Rollers	If the roller is dirty, clean it with a damp cloth then dry thoroughly.	Refer to Maintenance Check Items/Component Locations (P.316).
3	Sensors	Pick up & Registration & Manual paper sensor (IC51), Print timing sensor (IC50), Toner sensor (IC53), Exit sensor (IC52), confirm the operation of the sensors.	See Maintenance Check Items/Component Locations (P.316) and Sensors and Switches Section (P.77) Test Functions (P.136).
4	Glass	If the glass is dirty, clean them with a dry soft cloth.	Refer to Maintenance (P.318).
5	Abnormal, wear and tear or loose parts	Replace the part. Check if the screws are tight on all parts.	—

15.1.2.2. Maintenance Cycle (Document & Paper)

No.	Item	Cleaning Cycle
1	Pickup Roller (Ref.No.120)	-----
2	Transfer Roller (Ref.No.140)	-----
3	Registration Roller (Ref.No.149)	3 months
4	Heat Roller (Ref.No.75)	-----
5	Exit Roller (Ref.No.88)	3 months

If each part has got dirty, clean it with a damp cloth then dry thoroughly.

* These values are standard and may vary depending on usage conditions.

15.2. Maintenance

15.2.1. Cleaning the White Plates and Glass

Clean the white plates and glass when a black line, a white line or a dirty pattern appears on:

- your recording paper,
- the original document,
- the scanned data, or
- the fax document received by the other party.

Caution:

- **Do not use paper products, such as paper towels or tissues for cleaning.**

1. Open the document cover (1).

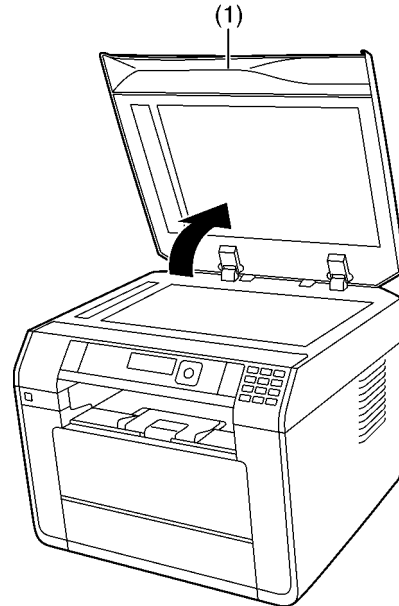

2. Hold the document cover while cleaning the white plates (1) and the scanner glass (2).

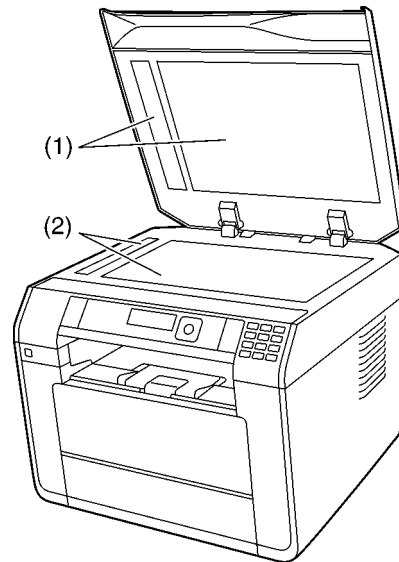

3. Close the document cover (1).

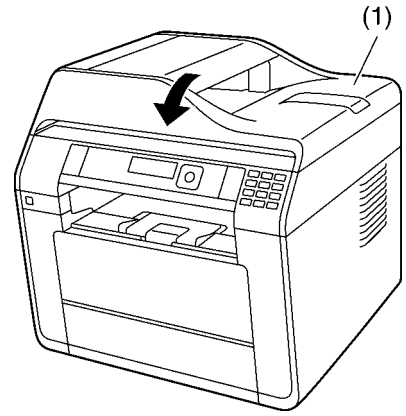

15.2.2. Cleaning the Document Feeder Rollers

Clean the rollers when documents frequently misfeed, or when a line or a dirty pattern appears on documents.

Caution:

- Do not use paper products, such as paper towels or tissues for cleaning.

1. Turn the power switch OFF.
2. Open the ADF cover (1) while holding the document cover (2).

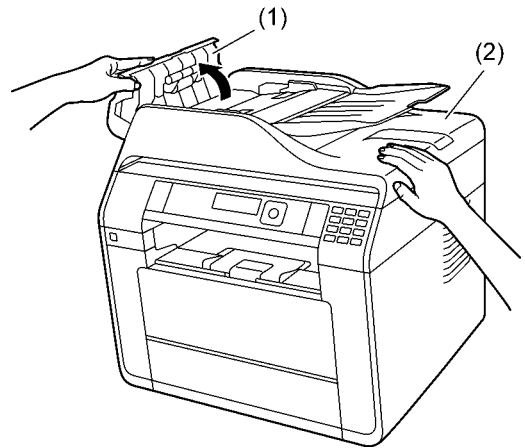

3. Clean the document feeder rollers (1) with a cloth moistened with water, and let all parts dry thoroughly.

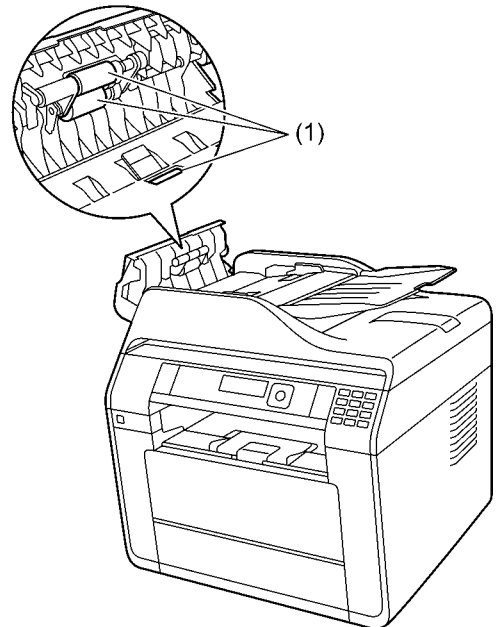

4. Close the ADF cover.

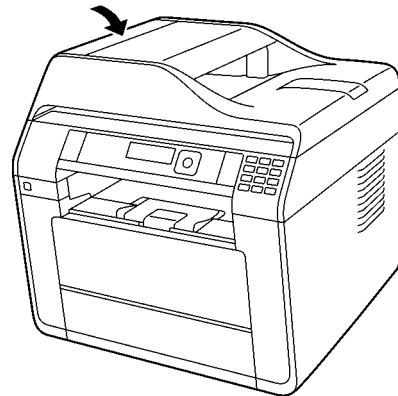

5. Turn the power switch ON.

15.2.3. Cleaning the recording paper feeder rollers of the multi-purpose tray

Clean the recording paper feeder rollers when documents fed from the multi-purpose tray frequently misfeed.

Caution:

- Do not use paper products, such as paper towels or tissues for cleaning.

1. Turn the power switch OFF.
2. Press the button (1) and open the front cover.

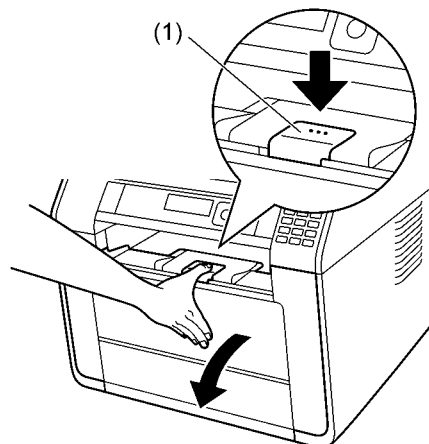

3. You can clean the recording paper feed rollers (1) with a cloth lightly moistened with water, and let all parts dry thoroughly.

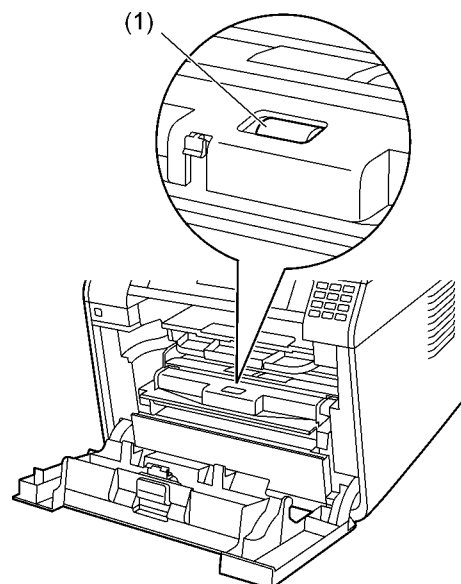

4. Close the front cover.

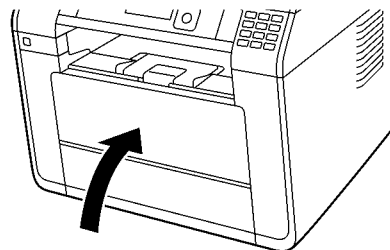

5. Turn the power switch ON.

15.2.4. Cleaning the pickup rollers

Clean the pickup rollers when documents fed from the standard input tray frequently misfeed.

Caution:

- Do not use paper products, such as paper towels or tissues for cleaning.

1. Turn the power switch OFF.
2. Pull the standard input tray (1) until it clicks into place, then pull it completely out, lifting the front part of the tray.

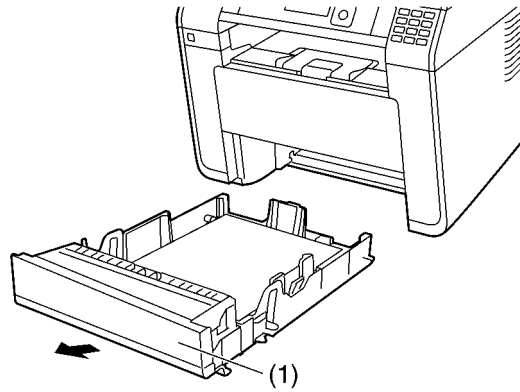

3. Clean the pickup rollers (1) with a cloth lightly moistened with water, and let all parts dry thoroughly.

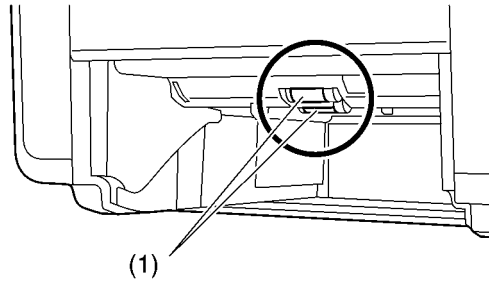

4. Insert the standard input tray into the unit, lifting the front part of the tray. Then push it completely into the unit.

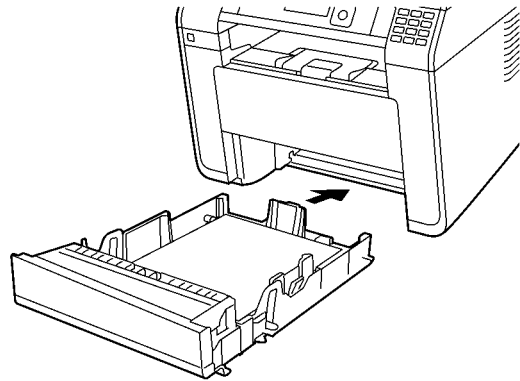

15.2.5. Cleaning the drum cartridge

Important:

- If the groove of the drum cartridge is dirty, lines or dirty patterns may appear on printed sheets. Be sure to remove any toner remaining on the inside of the drum cartridge to maintain the print quality.
- A cleaner for the drum cartridge is supplied with the replacement toner cartridge. If you replace only the toner cartridge, clean the drum cartridge using the cleaner.
- Insert the cleaner (1) into the left groove (2) and move it from side to side at least 3 times to clean the inside of the drum cartridge. Repeat this for the right groove (3).

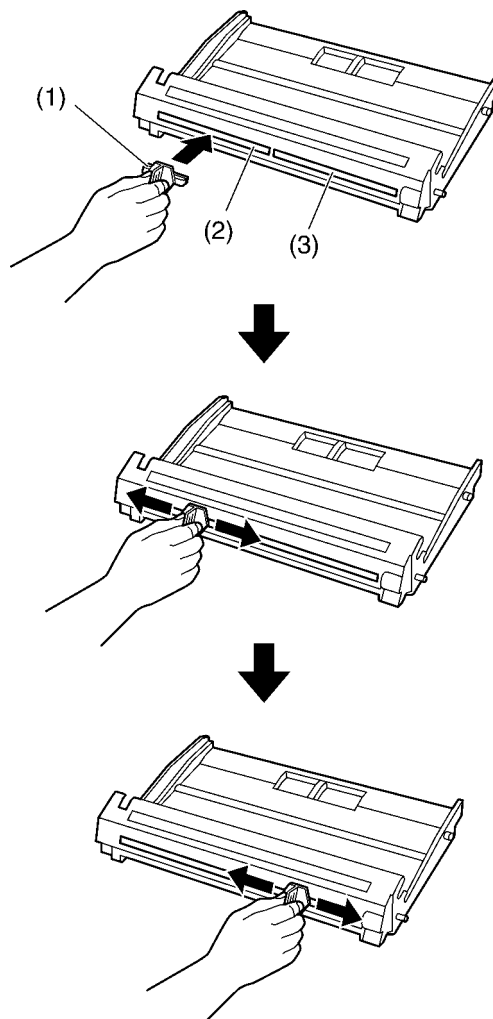

Note:

- Be sure to clean all the way to the edge of each groove.

15.3. Printing Operation Principle

15.3.1. Process Chart and Process BIAS

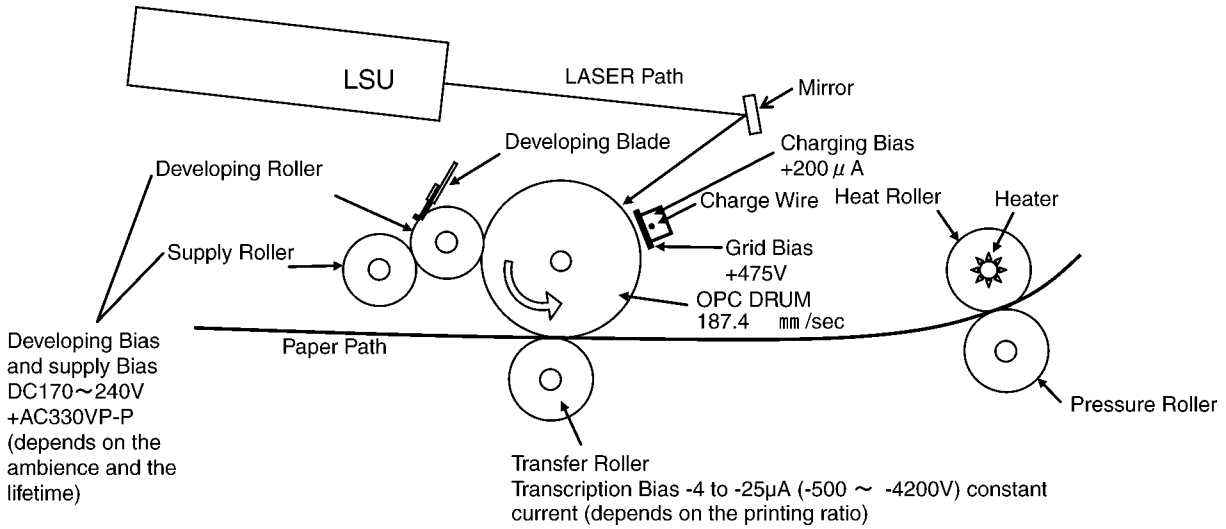

15.3.2. Charging

Charging is the stage that keeps the surface of the sensitive drum a fixed electric potential. The sensitive drum is the Organic Photo Conductor (OPC), which is a electric conductive cylinder whose surface is covered with the Charge Generation Transfer Layer (CGTL).

When the charging bias (DC +4.35 kiev) is added and the plus charge is supplied to the opc surface while charging, the whole surface potential of the drum is +475V.

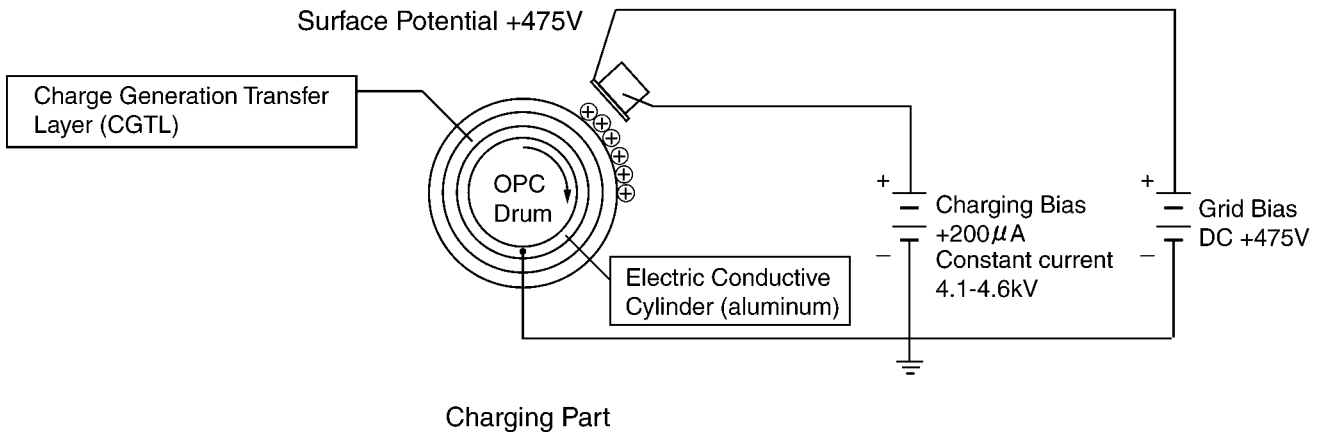

15.3.3. Exposing

When the drum which is charged with the fixed electric charge is irradiated by the laser beam, the plus charge and minus charge are generated at the Charge Generation Transfer Layer. Passing through the Charge Generation Transfer Layer which conducts the minus charge, the plus-charged drum's surface is neutralized to be skipped. Then the plus charge goes to the ground from the electric conductive cylinder. Consequently the charge of the part which is not exposed remains as it is, and the electric potential of the scanned part changes.

At that time an invisible image is created on the drum.

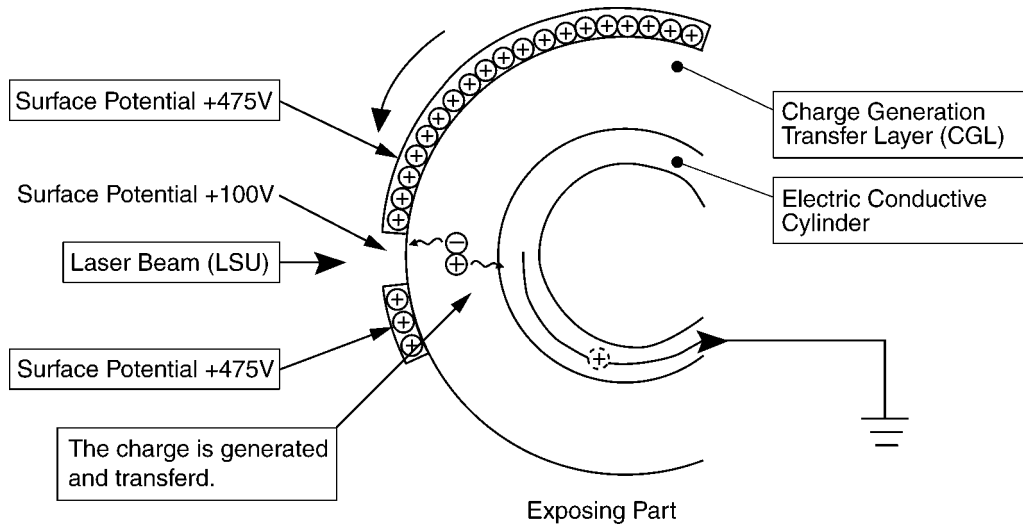

15.3.4. Developing and Transcription

The developing is the stage that the OPC drum with an invisible image is changed to visible by the toner. The drum unit consists of mixing paddle, toner supply roller, developing roller, developing blade, charge wire, grid plate and OPC drum. The bias voltage is added to the developing roller and toner supply roller. Firstly the toner is mixed up in the mixing paddle and plus-charged by triboelectricity, then led to the toner supply roller. Secondly the potential difference causes to send the toner to the developing roller from the toner supply roller. The supplied toner to the developing roller is kept to a certain layer thickness by the developing blade and also it is charged by triboelectricity. Consequently the toner is transferred to the surface of the exposed OPC drum by the potential difference between the developing roller and OPC drum's surface.

The transfer is the stage that the created image on the OPC drum is transferred to the paper. When the transfer roller is minus-charged with the image, the plus-charged toner particles are gathered on the surface of the drum and transferred to the paper.

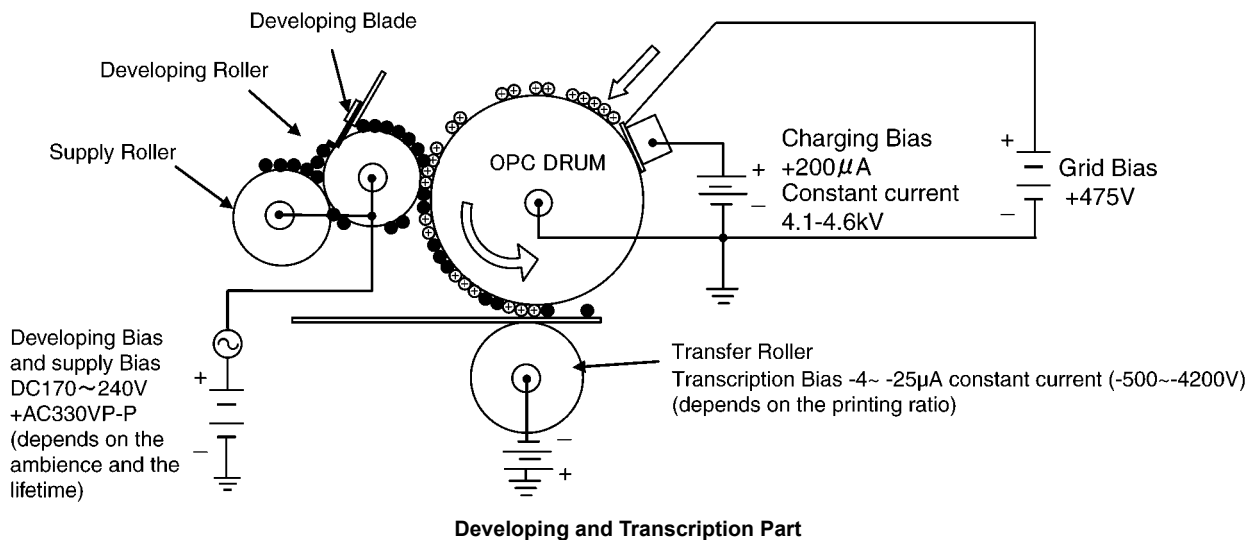

15.3.5. Cleaning of Transfer Roller

The toner attached to the surface of the OPC drum is transferred to the paper at the transcription stage, but a part of the toner remains. The cleaning is the stage that cleans the remain toner after the transcription stage. The remain toner on the drum and the toner which was attached to the place where the laser beam didn't scan are gathered to the developing roller to be used again. After paper jam or replacing toner and drum unit, the transfer roller is plus-charged to eliminate the plus-charged toner.

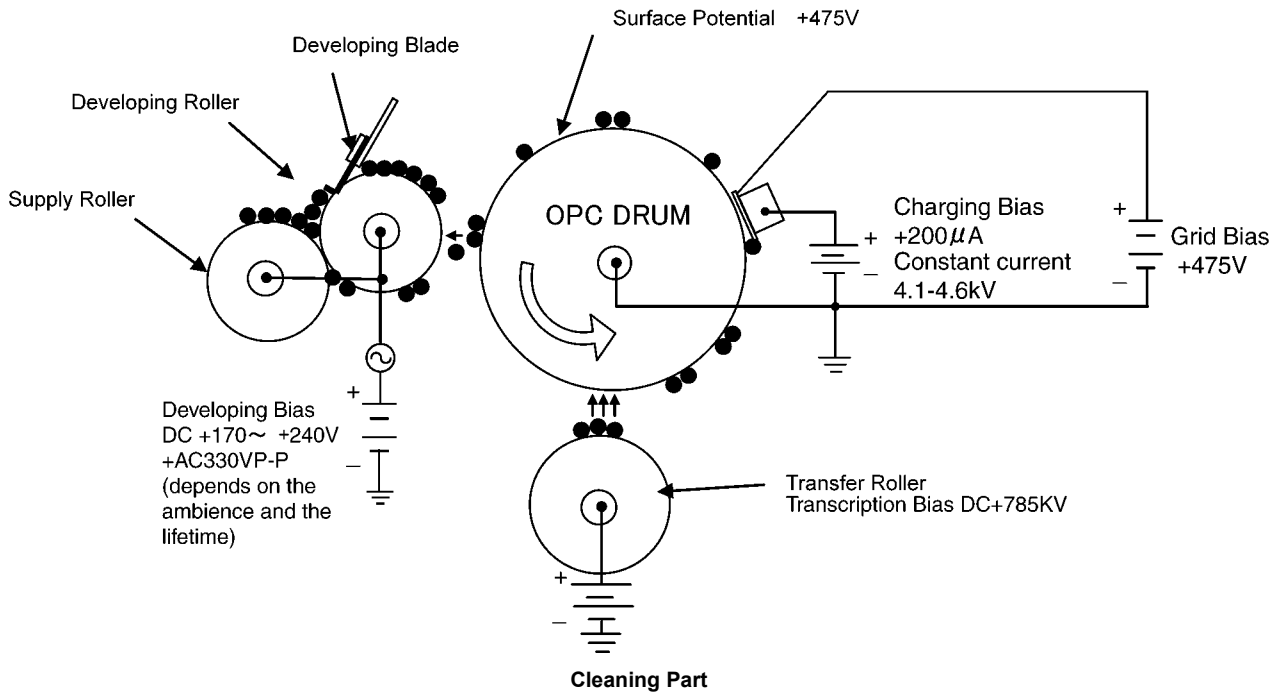

15.3.6. Fixing

On the process of the transfer, the transferred toner is weakly attached on the paper. Fixing means the process to fix the toner on the paper permanently. The fixing part melts the toner at the high temperature using the halogen heater. The toner is fixed on the paper by the heat and pressure through the fixing part with the image. The surface of the heat roller is rosined by Teflon and lubricated to prevent from attaching the toners. The press roller is made of silicon, and its spring compresses the melted toner.

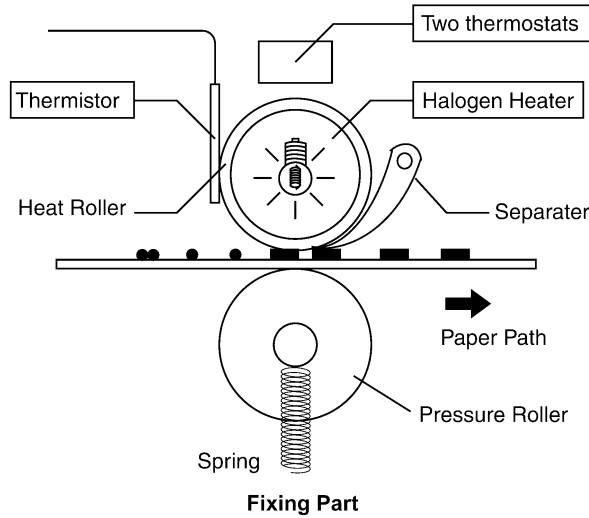

Fixing Part

The fixing part becomes high temperature, so the thermistor and the two thermostats are provided.

1. Thermistor

The thermistor touches the heat roller and check the temperature to feed back to the control circuit. The surface temperature should be kept 195°C while printing.





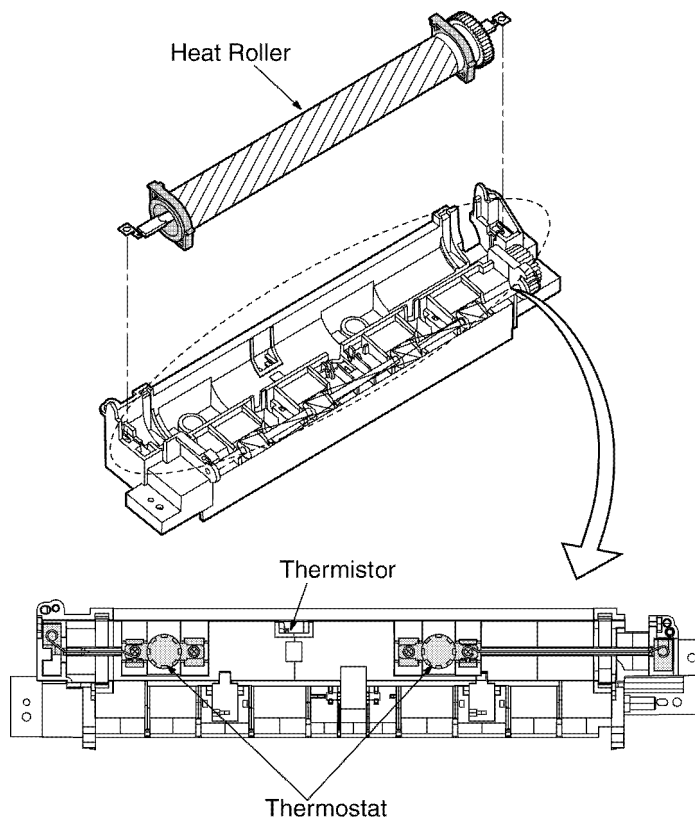





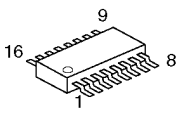
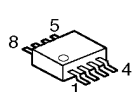
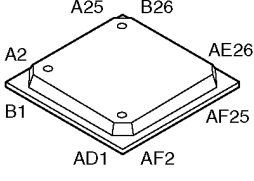

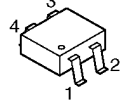
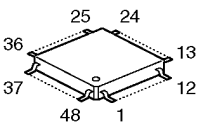
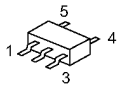
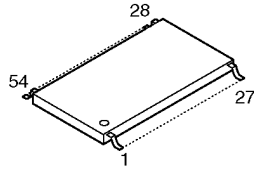
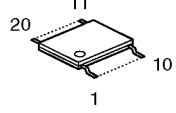
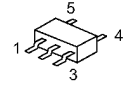
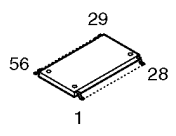
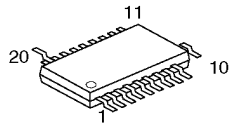
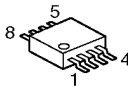
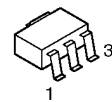
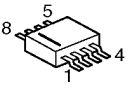
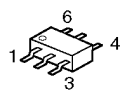
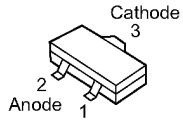
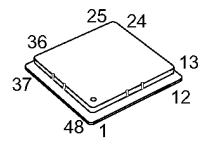

2. Thermostat

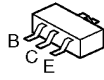
The thermostat is located near the heat roller, and it turns OFF the power when the temperature around the thermostat becomes over 160°C.

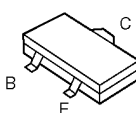

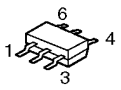
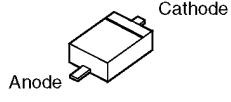

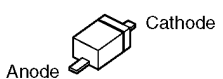
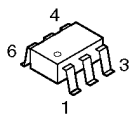
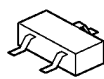

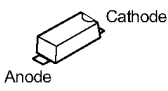
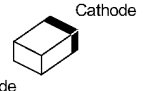
15.4. Terminal Guide of the ICs Transistors and Diodes



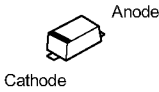

15.4.1. Main Board(1)

 <p>C1CB00002689 C1CB00002690 C1CB00001769 C0ZBZ0001747</p>	 <p>C1AB00002556</p>	 <p>C1ZBZ0004649</p>	 <p>C0EBY0000665</p>	 <p>IC303 C0DBGYY03947</p>
 <p>C1ZBZ0003879 C1CB00003704</p>	 <p>IC304 C0DBZYY00592</p>	 <p>C3ABRY000078</p>	 <p>C0JBAZ001466 C0JBAZ001539</p>	 <p>C0JBAA000362</p>
 <p>AN44071A</p>	 <p>IC503 C0FBAY000092</p>	 <p>IC504 C0BBBA000024</p>	 <p>IC803 C0DBEYY00102</p>	 <p>IC800 C0DBAYY01433</p>
 <p>C0DBAYY00932</p>	 <p>PJVDJADAN202</p>	 <p>IC850 C5ZBZ0000133</p>	 <p>IC851 C0ZBZ0001182</p>	 <p>DSC710100L</p>
 <p>B1ABDP000005</p>	 <p>B1ADKE000002 B1ADGP000008</p>	 <p>DSC9001R0L</p>	 <p>B1ABGE000014</p>	 <p>B1ABGE000011 B0ADEJ000025 B1CHND000004</p>
 <p>B1CHQD000018</p>	 <p>DZ2W30000L</p>	 <p>B0EDER000009</p>	 <p>DA2J10100L</p>	 <p>DZ2J056M0L</p>
 <p>B0ZBZ0000146</p>	 <p>B1ADCF000020 B1ADGE000012 B1GBCFGN0005</p>	 <p>B0JCND000031</p>	 <p>B0BC6R5A0541</p>	 <p>B3ABB0000331</p>

15.4.2. Main Board(2)

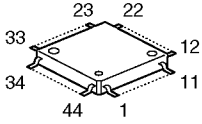
 <p>DD2S06200L</p>	 <p>DRA9143Z0L</p>	<p>Q105</p>  <p>DRC9123J0L</p>	 <p>DZ2W05600L</p>	
---	---	--	---	--

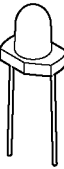

15.4.3. Operation Board

 <p>C1ZBZ0004019</p>	 <p>B1ABGE000011</p>	 <p>DRC5143E0L DRC5123J0L DRA5144E0L</p>	 <p>DA2J10100L</p>	 <p>B3ABA0000633</p>
---	---	---	---	---

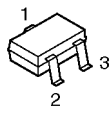
15.4.4. Print Sensor Relay Board

 <p>B4ABC0000053</p>
--

15.4.5. Center Relay Board

 <p>DA2J10100L</p>	 <p>PJVDJADAN202</p>
---	---

15.4.6. Varistor Board

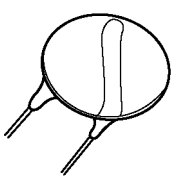
 <p>ERZVA7D271</p>

15.4.7. ADF Relay Board

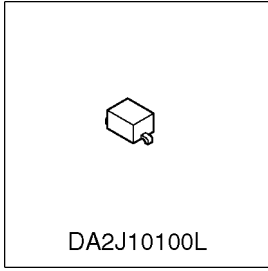

15.4.8. MPT Relay Board

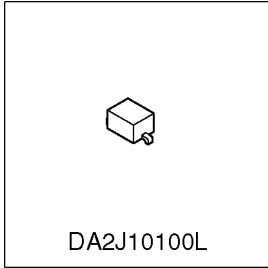

15.4.9. High Voltage Power Supply Board (HVPS Board)

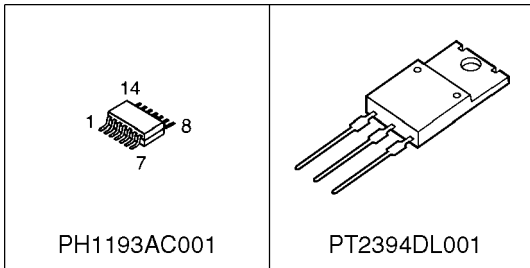

15.4.10. Low Voltage Power Supply Board (SMPS Board)

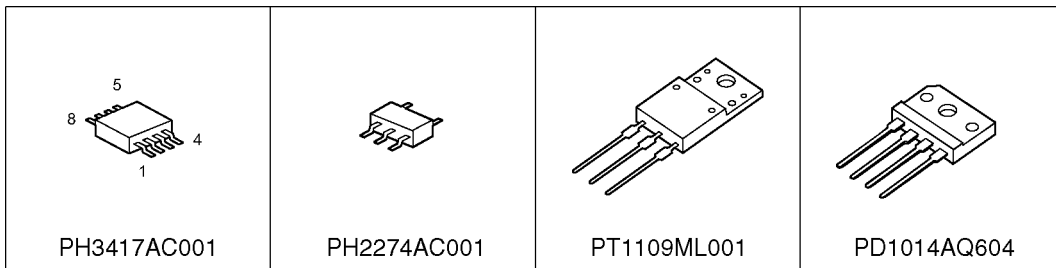

15.5. How to Replace the Flat Package IC

Even if you do not have the special tools (for example, a spot heater) to remove the Flat IC, with some solder (large amount), a soldering iron and a cutter knife, you can easily remove the ICs that have more than 100 pins.

15.5.1. Preparation

- PbF (: Pb free) Solder

- Soldering Iron

Tip Temperature of 700°F ± 20°F (370°C ± 10°C)

Note: We recommend a 30 to 40 Watt soldering iron. An expert may be able to use a 60 to 80 Watt iron where someone with less experience could overheat and damage the PCB foil.

- Flux

Recommended Flux: Specific Gravity → 0.82.

Type → RMA (lower residue, non-cleaning type)

Note: See **About Lead Free Solder (PbF: Pb free)** (P.8).

15.5.2. Removal Procedure

1. Put plenty of solder on the IC pins so that the pins can be completely covered.

Note:

If the IC pins are not soldered enough, you may give pressure to the P.C. board when cutting the pins with a cutter.

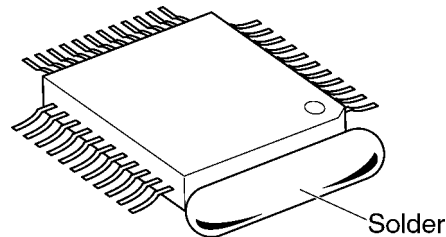

2. Make a few cuts into the joint (between the IC and its pins) first and then cut off the pins thoroughly.

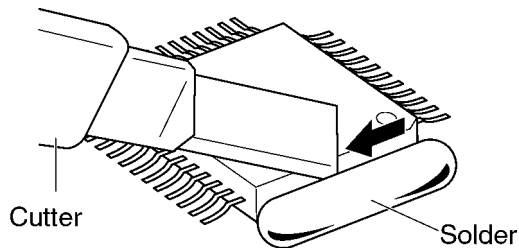

3. While the solder melts, remove it together with the IC pins.

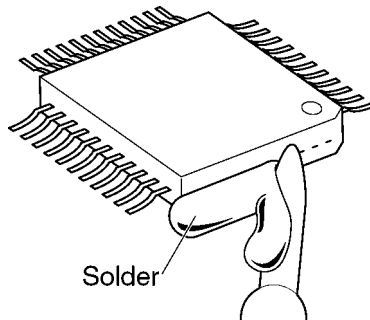

When you attach a new IC to the board, remove all solder left on the land with some tools like a soldering wire. If some solder is left at the joint on the board, the new IC will not be attached properly.

15.5.3. Procedure

1. Tack the flat pack IC to the PCB by temporarily soldering two diagonally opposite pins in the correct positions on the PCB.

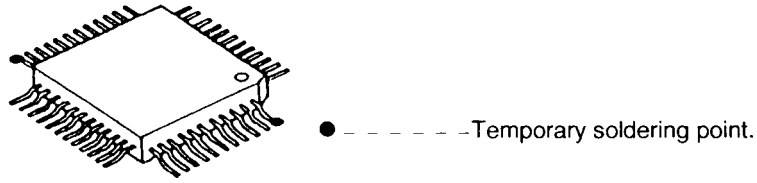

*Be certain each pin is located over the correct pad on the PCB.

2. Apply flux to all of the pins on the IC.

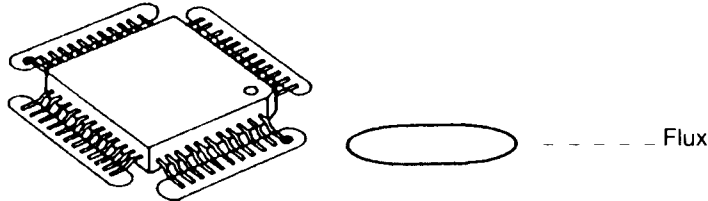

3. Being careful to not unsolder the tack points, slide the soldering iron along the tips of the pins while feeding enough solder to the tip so that it flows under the pins as they are heated.

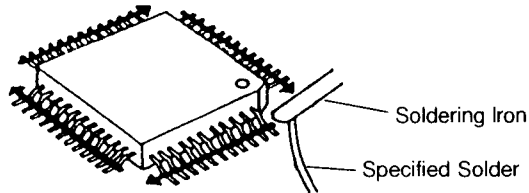

15.5.4. Removing Solder From Between Pins

1. Add a small amount of solder to the bridged pins.
2. With a hot iron, use a sweeping motion along the flat part of the pin to draw the solder from between the adjacent pads.

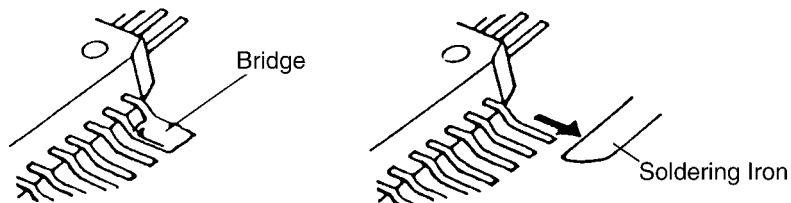

15.6. Main Board Section

When the unit fails to boot up the system, take the troubleshooting procedures very carefully. It may have a serious problem.

The symptom: No response when the power is turned on. (No LCD display, and keys are not accepted.)

The first step is to check the power source. If there is no problem with the power supply board, the problem may lie in the digital unit (main board).

As there are many potential causes in this case (ASIC, DRAM, etc.), it may be difficult to specify what you should check first. If a mistake is made in the order of checks, a normal part may be determined faulty, wasting both time and money.

Although the tendency is to regard the problem as a serious one (IC malfunction, etc.), usually most cases are caused by solder faults (poor contact due to a tunnel in the solder, signal short circuit due to solder waste).

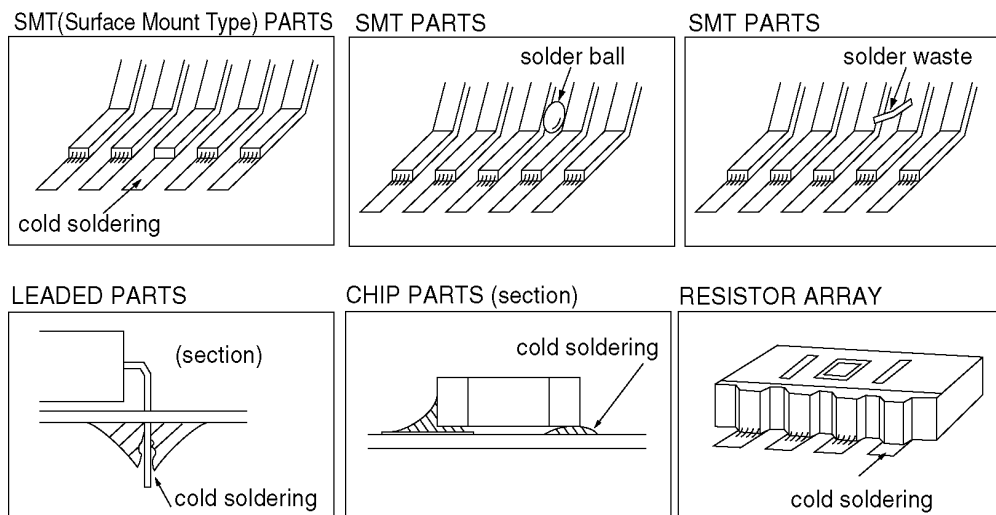

Note:

1. Electrical continuity may have existed at the factory check, but a faulty contact occurred as a result of vibration, etc., during transport.

2. Solder waste remaining on the board may get caught under the IC during transport, causing a short circuit.

Before we begin mass production, several hundred trial units are produced at the plant, various tests are applied and any malfunctions are analyzed. (In past experiences, digital IC (especially, DRAM and ROM) malfunctions are extremely rare after installation in the product.)

This may be repaired by replacing the IC, (DRAM etc.). However, the real cause may not have been an IC malfunction but a soldering fault instead.

Soldering faults difficult to detect with the naked eye are common, particularly for ASIC and RA (Resistor Array). But if you have an oscilloscope, you can easily determine the problem site or IC malfunction by checking the main signal lines.

Even if you don't have such a measuring instrument, by checking each main signal line and resoldering it, in many cases the problem will be resolved.

An explanation of the main signals (for booting up the unit) is presented below.

Don't replace ICs or stop repairing until checking the signal lines.

An IC malfunction rarely occurs. (By understanding the necessary signals for booting up the unit, the "Not Boot up" display is not a serious problem.)

What are the main signals for booting up the unit?

Please refer to **General Block Diagram** (P.31).

The SOC (System On Chip) controls all the other digital ICs. When the power is turned on, the SOC retrieves the operation code stored in the Flash ROM, then follows the instructions for controlling each IC. All ICs have some inner registers that are assigned to a certain address.

It is the address bus by which the SOC designates the location inside each IC. And the data bus reads or writes the data in order to transmit the instructions from the SOC to the ICs.

These signal lines are all controlled by voltages of 3.3V (H) or 0V (L).

15.6.1. NG Example

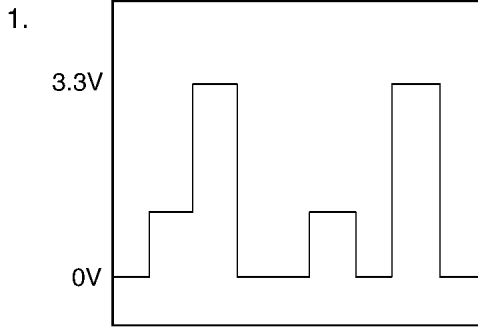

Short circuit from the adjacent signal wires.
Check for a short circuit in the RA and IC leads and the signal wire at the through hole.

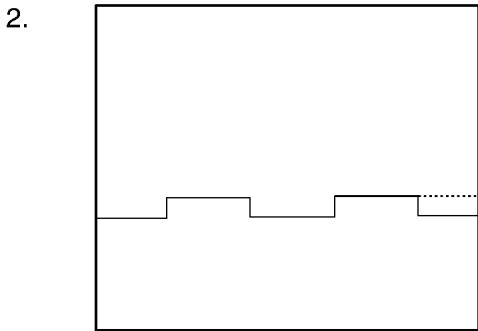
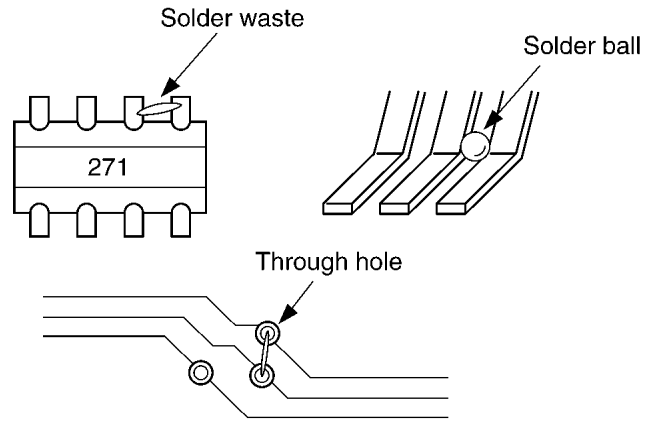

Short between the signal line and GND.

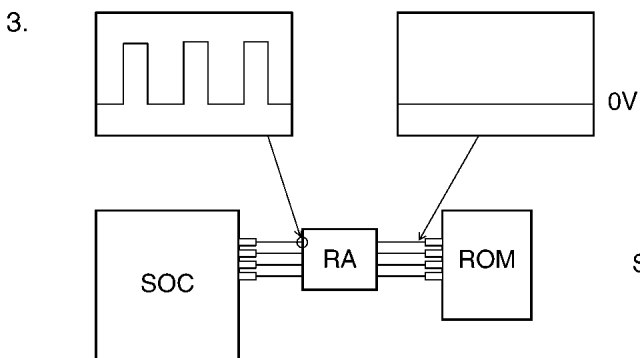
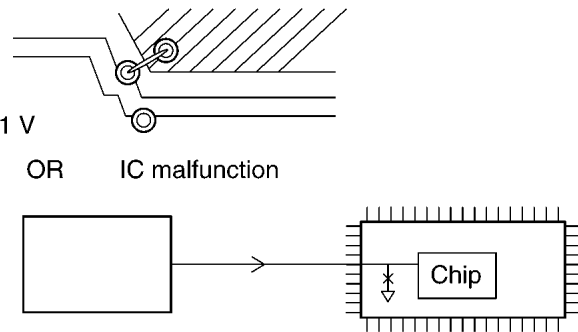

Solder fault on RA.

15.7. Test Chart

15.7.1. ITU-T No.1 Test Chart



THE SLEREXE COMPANY LIMITED

SAPORS LANE - BOOLE - DORSET - BH 25 8 ER

TELEPHONE BOOLE (945 13) 51617 - TELEX 123456

Our Ref. 350/PJC/EAC

18th January, 1972.

Dr. P.N. Cundall,
Mining Surveys Ltd.,
Holroyd Road,
Reading,
Berks.

Dear Pete,

Permit me to introduce you to the facility of facsimile transmission.

In facsimile a photocell is caused to perform a raster scan over the subject copy. The variations of print density on the document cause the photocell to generate an analogous electrical video signal. This signal is used to modulate a carrier, which is transmitted to a remote destination over a radio or cable communications link.

At the remote terminal, demodulation reconstructs the video signal, which is used to modulate the density of print produced by a printing device. This device is scanning in a raster scan synchronised with that at the transmitting terminal. As a result, a facsimile copy of the subject document is produced.

Probably you have uses for this facility in your organisation.

Yours sincerely,

Phil.

P.J. CROSS
Group Leader - Facsimile Research

15.7.2. ITU-T No.2 Test Chart

CCITT N° 2 : Mire pour test de Transmission

QS2DR QS2DR	KWJ4H KWJ4H	S5TR7 S5TR7	QS2DR QS2DR	KWJ4H KWJ4H	S5TR7 S5TR7	BC6IT BC6IT	ZP3FM ZP3FM	XB8UG XB8UG	BC6IT BC6IT	ZP3FM ZP3FM	XB8UG XB8UG
Transmission Test Group n° I Character UNIVERS SIZE 8 ABCDEFGHIJKLMNOPQRSTUVWXYZ abcdefghijklmnopqrstuvwxyz 0123456789 S ² œ ♦ [] Ç □ . £ - ± × : ° © ● ß _ é + = \$ / () & % *						Transmission Test Group n° III Character ENGLISH-TIMES SIZE 8 ABCDEFGHIJKLMNOPQRSTUVWXYZ abcdefghijklmnopqrstuvwxyz 0123456789 S ² œ ♦ [] Ç □ . £ - ± × : ° © ● ß _ é + = \$ / () & % *					
Transmission Test Group n° II Character UNIVERS SIZE 10						Transmission Test Group n° IV Character ENGLISH-TIMES SIZE 10					
Groupe n° I pour test de transmission caractères UNIVERS 8 POINTS ABCDEFGHIJKLMNOPQRSTUVWXYZ abcdefghijklmnopqrstuvwxyz 0123456789 S ² œ ♦ [] Ç □ . £ - ± × : ° © ● ß _ é + = \$ / () & % *						Groupe n° III pour test de transmission composé de caractères ENGLISH-TIMES 8 POINTS ABCDEFGHIJKLMNOPQRSTUVWXYZ abcdefghijklmnopqrstuvwxyz 0123456789 S ² œ ♦ [] Ç □ . £ - ± × : ° © ● ß _ é + = \$ / () & % *					
Groupe n° II pour test de transmission caractères UNIVERS 10 POINTS						Groupe n° IV pour test de transmission composé de caractères ENGLISH-TIMES 10 POINTS					
Grupo n° I para prueba de transmisión de los caracteres UNIVERS 8 PUNTOS ABCDEFGHIJKLMNOPQRSTUVWXYZ abcdefghijklmnopqrstuvwxyz 0123456789 S ² œ ♦ [] Ç □ . £ - ± × : ° © ● ß _ é + = \$ / () & % *						Grupo n° III para prueba de transmisión de los caracteres ENGLISH-TIMES 8 PUNTOS ABCDEFGHIJKLMNOPQRSTUVWXYZ abcdefghijklmnopqrstuvwxyz 0123456789 S ² œ ♦ [] Ç □ . £ - ± × : ° © ● ß _ é + = \$ / () & % *					
Grupo n° II para prueba de transmisión de los caracteres UNIVERS 10 PUNTOS						Grupo n° IV para prueba de transmisión de los caracteres ENGLISH-TIMES 10 PUNTOS					
傳輸試驗用字第一組 13.75P 万有引力 科学方法 男女体操 文化交流 地理条件 家庭用品 共同研究 相互往来 新春景色 主要内容 世界各国 普通教育			傳輸試驗用字第二組 10.5P 万有引力 科学方法 男女体操 文化交流 地理条件 家庭用品 共同研究 相互往来 新春景色 主要内容 世界各国 普通教育			傳輸試驗用字第三組 7.875P 万有引力 科学方法 男女体操 文化交流 地理条件 家庭用品 共同研究 相互往来 新春景色 主要内容 世界各国 普通教育					
المجموعة الثانية خط الرقعة آء أ ا ب ء ذ ز ه ح د ذ ر ز س ش ص ض ط ظ ع ف ذ ك ل م ن ه و ث ي ب ت ج ح خ س ش ص ض ع ف غ ق ك ل م ن ه ي لا لا						المجموعة الأولى خط النسخ آء أ ا ب ء ذ ز ه ح د ذ ر ز س ش ص ض ط ظ ع ف ذ ك ل م ن ه و ث ي ب ت ج ح خ س ش ص ض ع ف غ ق ك ل م ن ه ي لا لا					
ГРУППА № 1-ДЛЯ ИСПЫТАНИЯ ПЕРЕДАЧИ БУКВА КЕГЛЬ 8 АБВГДЕЖЗИЙКЛМНОПРСТУФХЦЧШЩЪЫЬЭЮЯ абвгдежзийклмнопрстуфхцчшщъыьэюя 1234567890						ГРУППА № 3-ДЛЯ ИСПЫТАНИЯ ПЕРЕДАЧИ БУКВА КЕГЛЬ 8 АБВГДЕЖЗИЙКЛМНОПРСТУФХЦЧШЩЪЫЬЭЮЯ абвгдежзийклмнопрстуфхцчшщъыьэюя 1234567890					
ГРУППА № 2-ДЛЯ ИСПЫТАНИЯ ПЕРЕДАЧИ БУКВА КЕГЛЬ 10						ГРУППА № 4-ДЛЯ ИСПЫТАНИЯ ПЕРЕДАЧИ БУКВА КЕГЛЬ 10					

16 Schematic Diagram

16.1. For Schematic Diagram

Note:

1. DC voltage measurements are taken with an oscilloscope or a tester with a ground.
2. The schematic diagrams and circuit board may be modified at any time with the development of new technology.

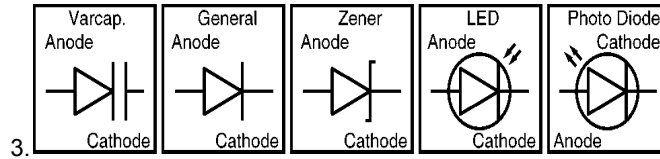

Important safety notice

Components identified by \triangle mark have special characteristics important for safety. When replacing any of these components, use only the manufacturer's specified parts.

16.2. Main Board (KX-MB2230)

16.2.1. Main Board(1)

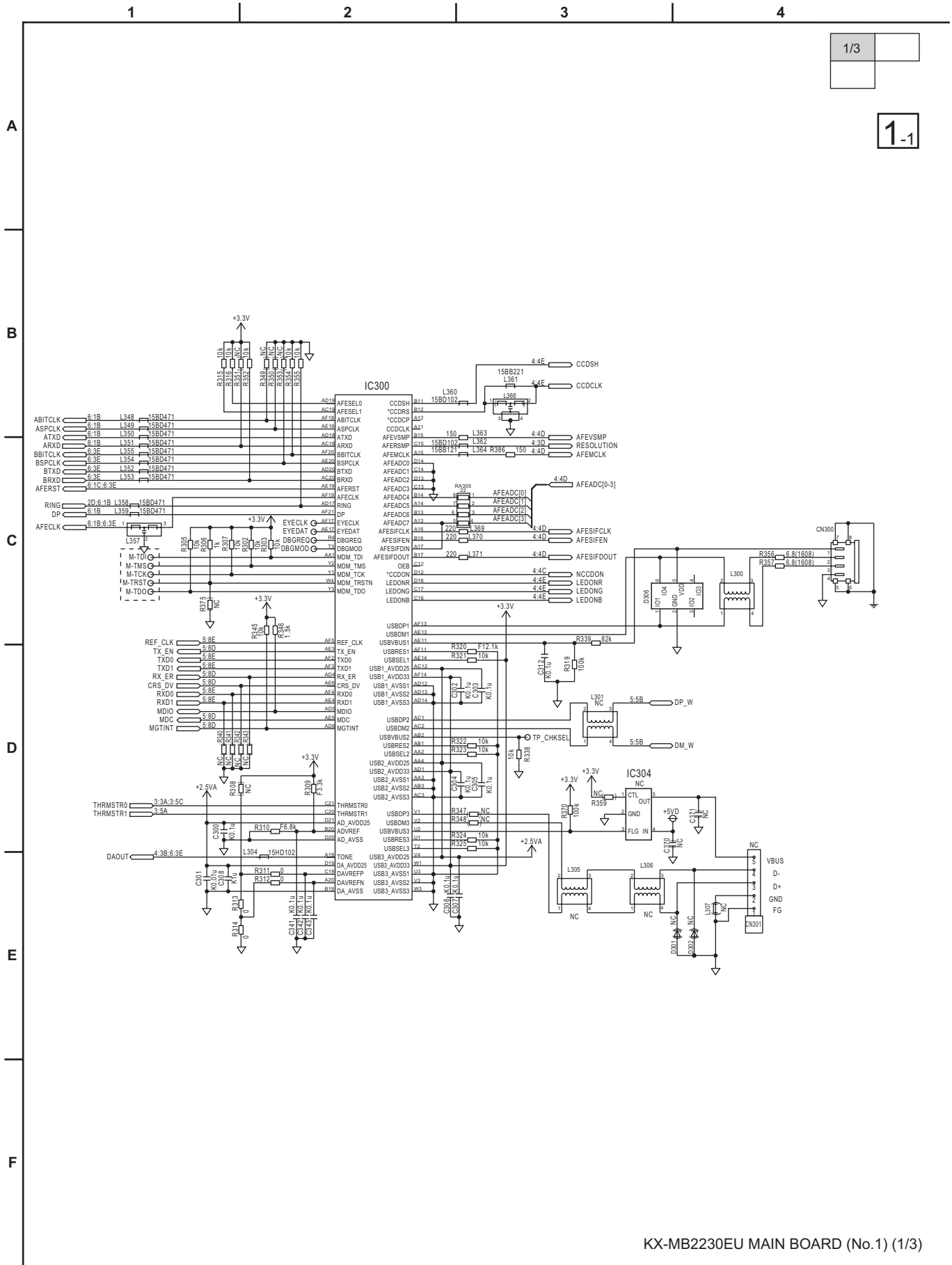

KX-MB2230EU MAIN BOARD (No.1) (1/3)

5

6

7

8

2/3

1-2

A

B

C

D

E

F

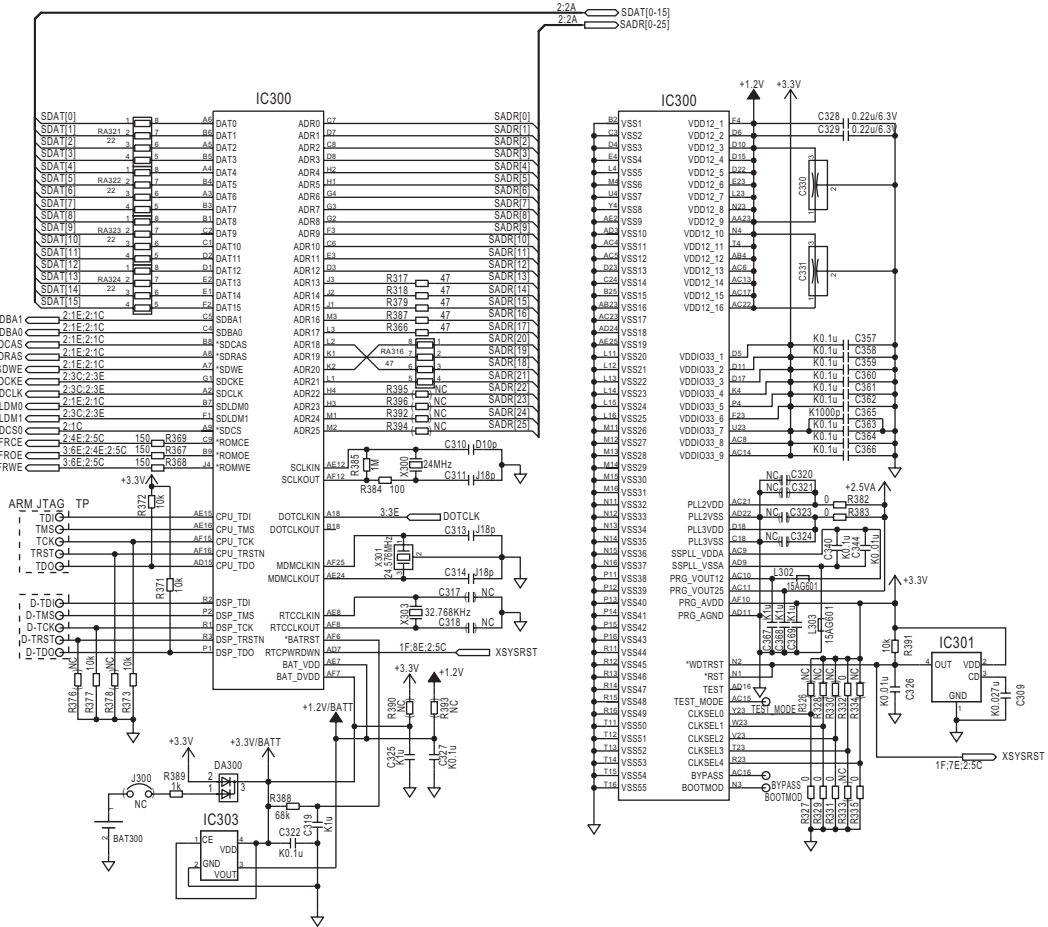

KX-MB2230EU MAIN BOARD (No.1) (2/3)

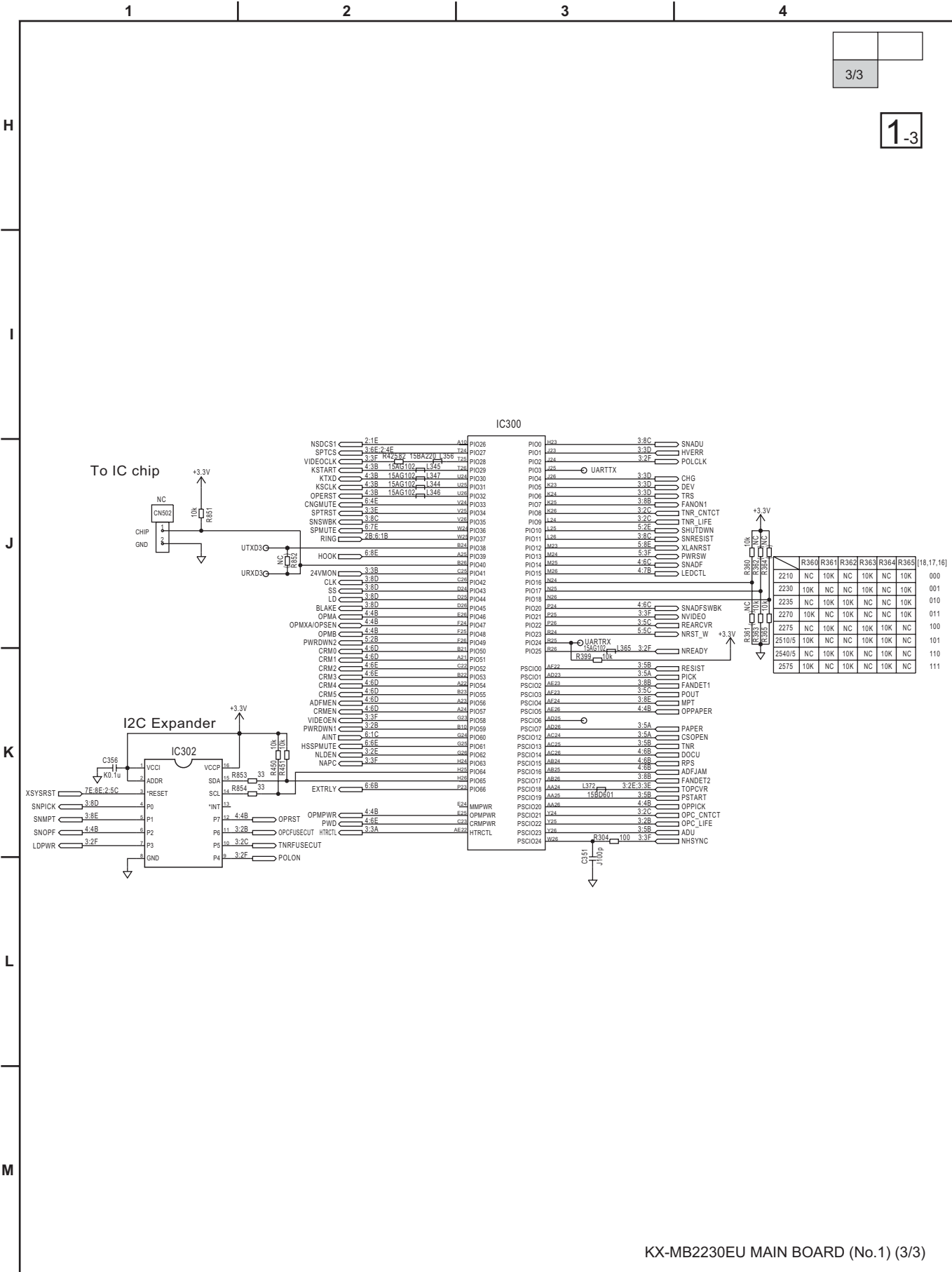

KX-MB2230EU MAIN BOARD (No.1) (3/3)

Memo

16.2.2. Main Board(2)

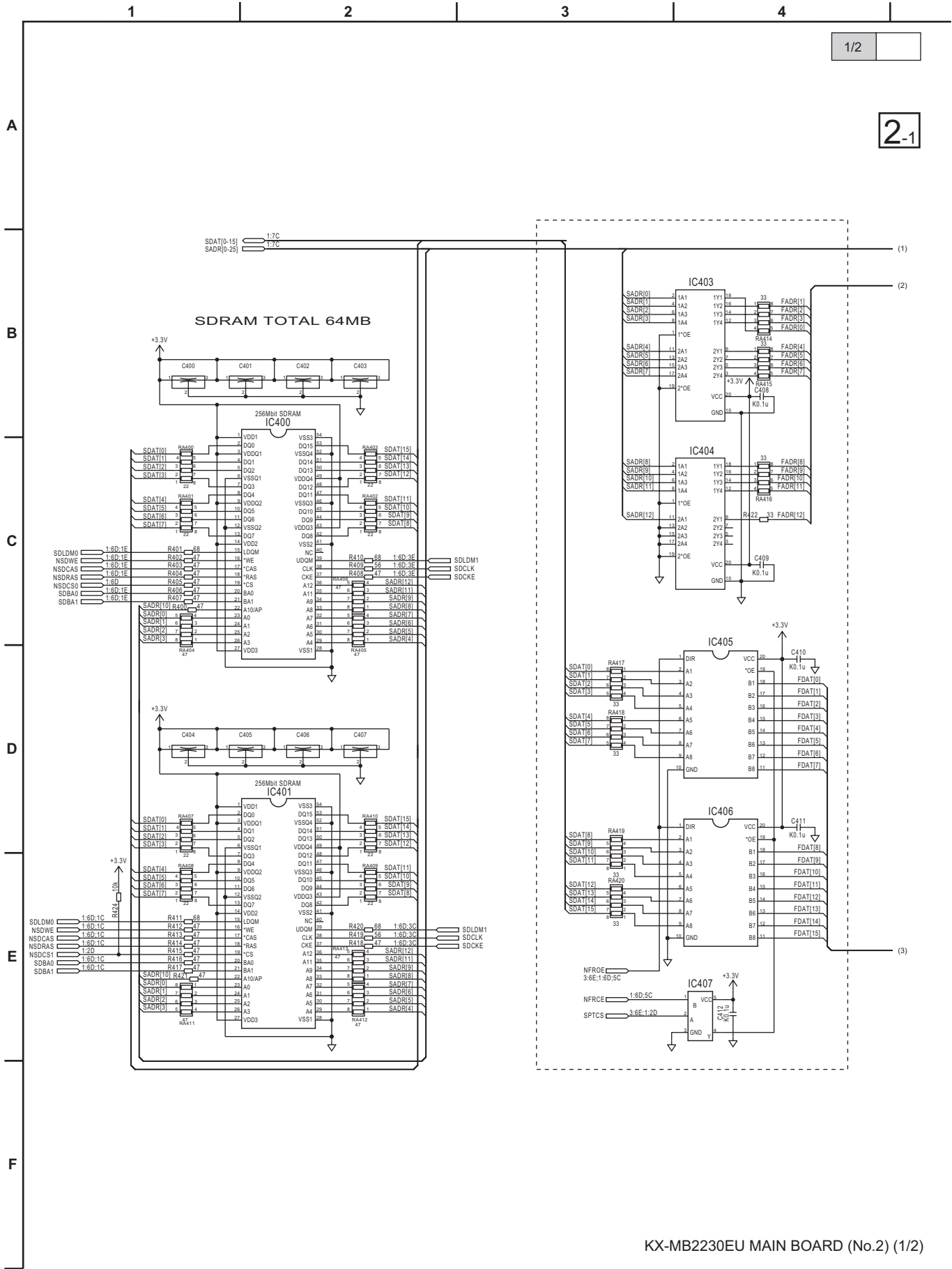

1/2

2-1

KX-MB2230EU MAIN BOARD (No.2) (1/2)

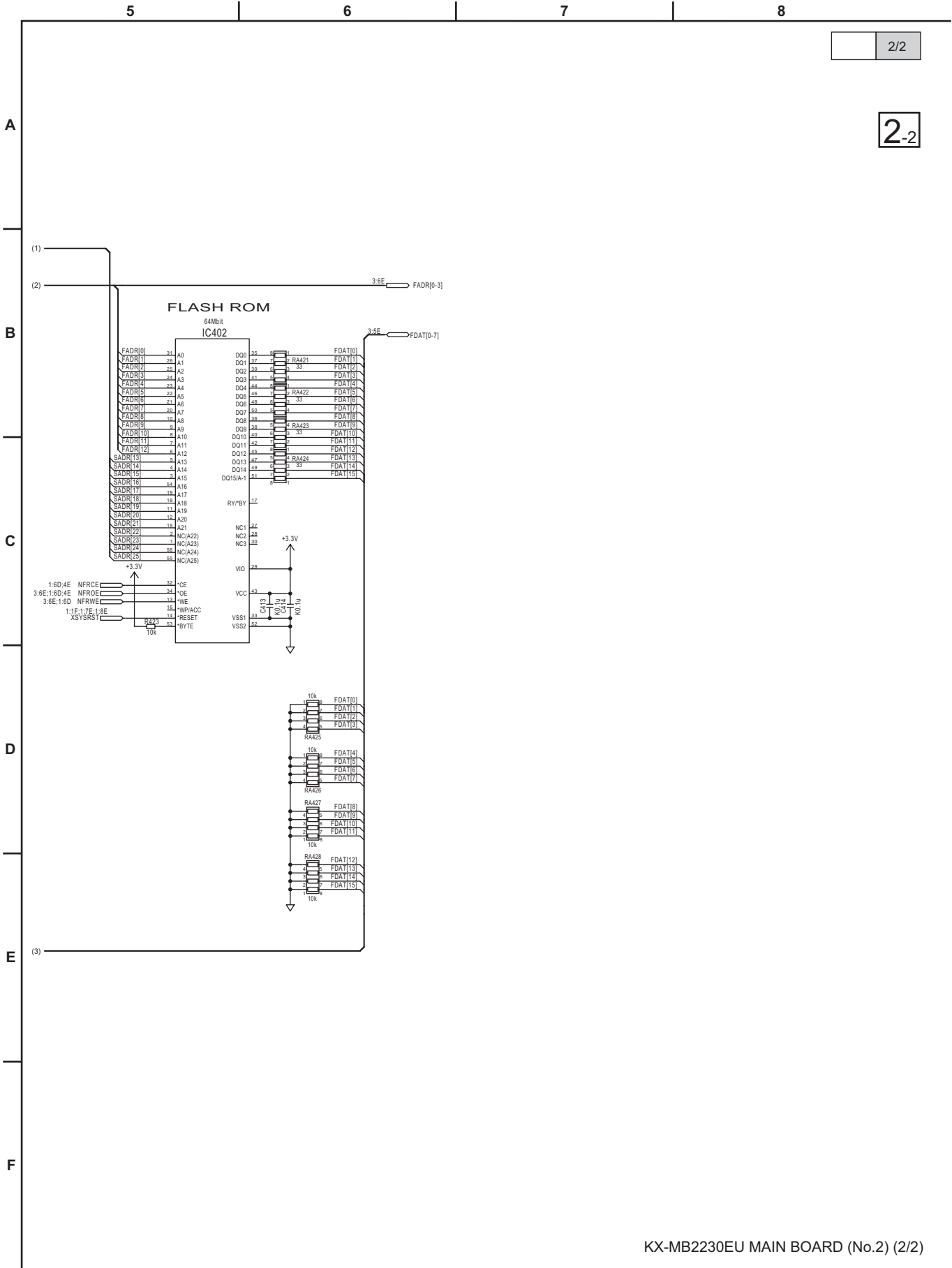

KX-MB2230EU MAIN BOARD (No.2) (2/2)

16.2.3. Main Board(3)

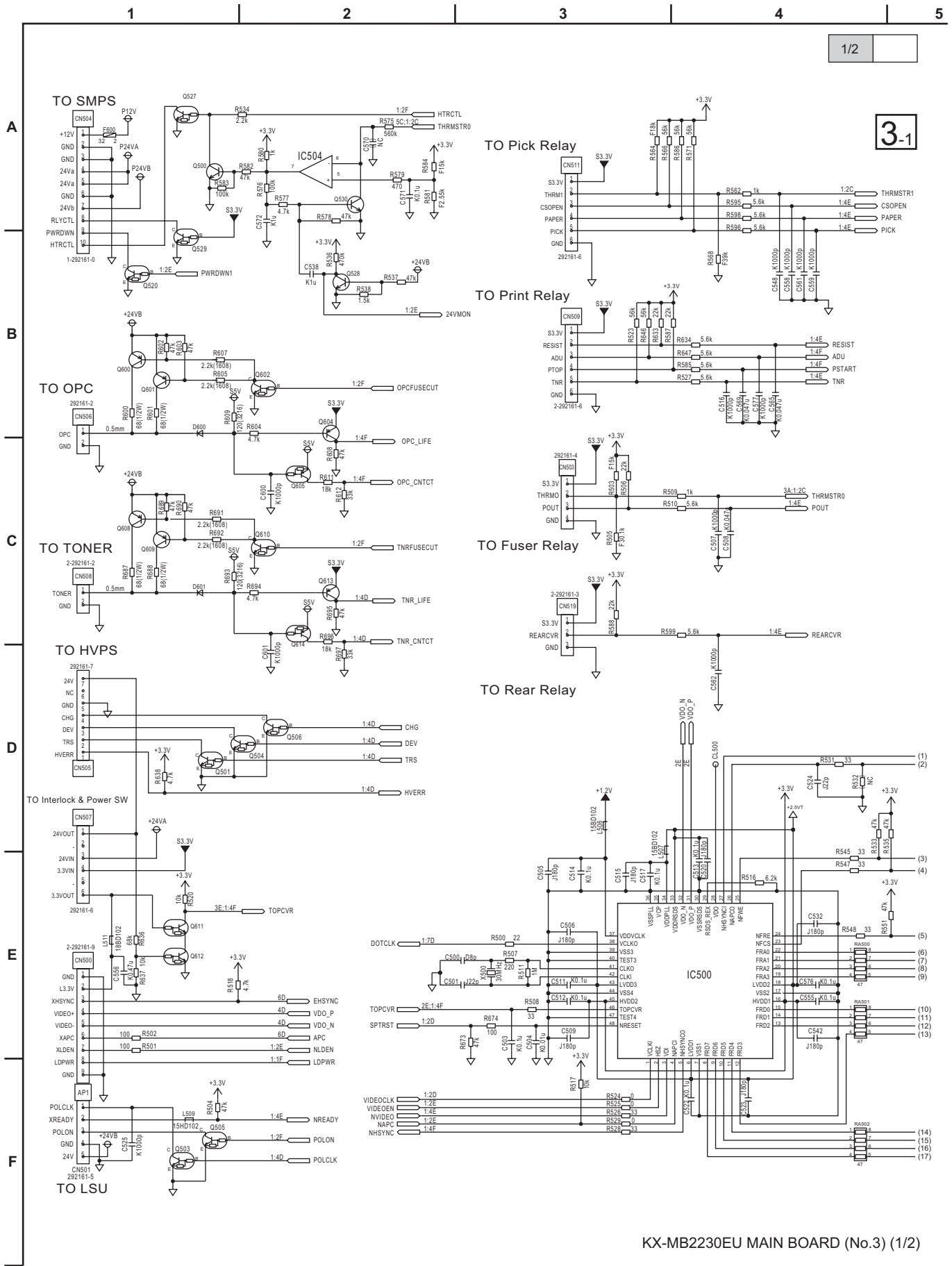

KX-MB2230EU MAIN BOARD (No.3) (1/2)

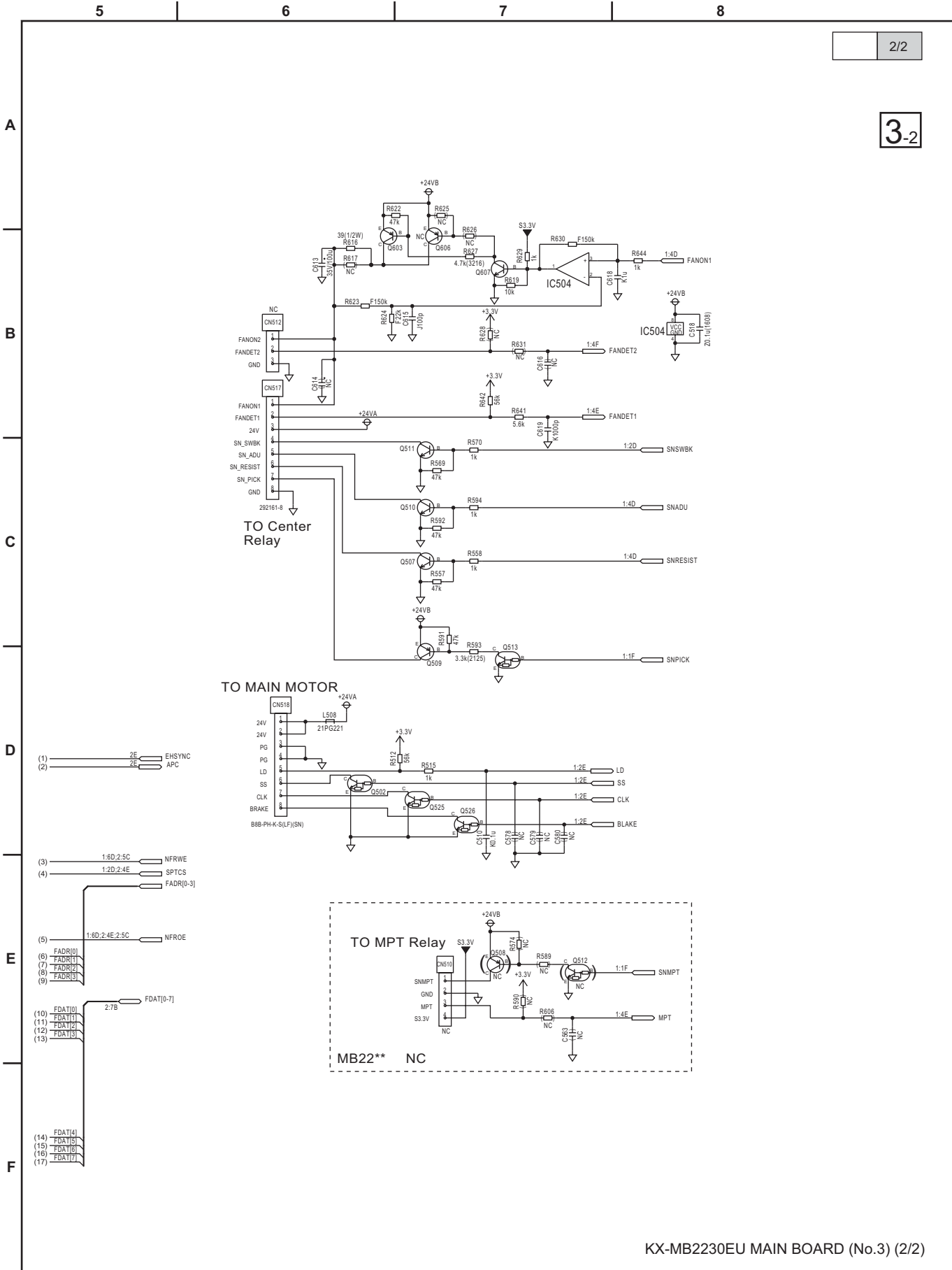

KX-MB2230EU MAIN BOARD (No.3) (2/2)

5

6

7

8

2/2

4-2

A

B

C

D

E

F

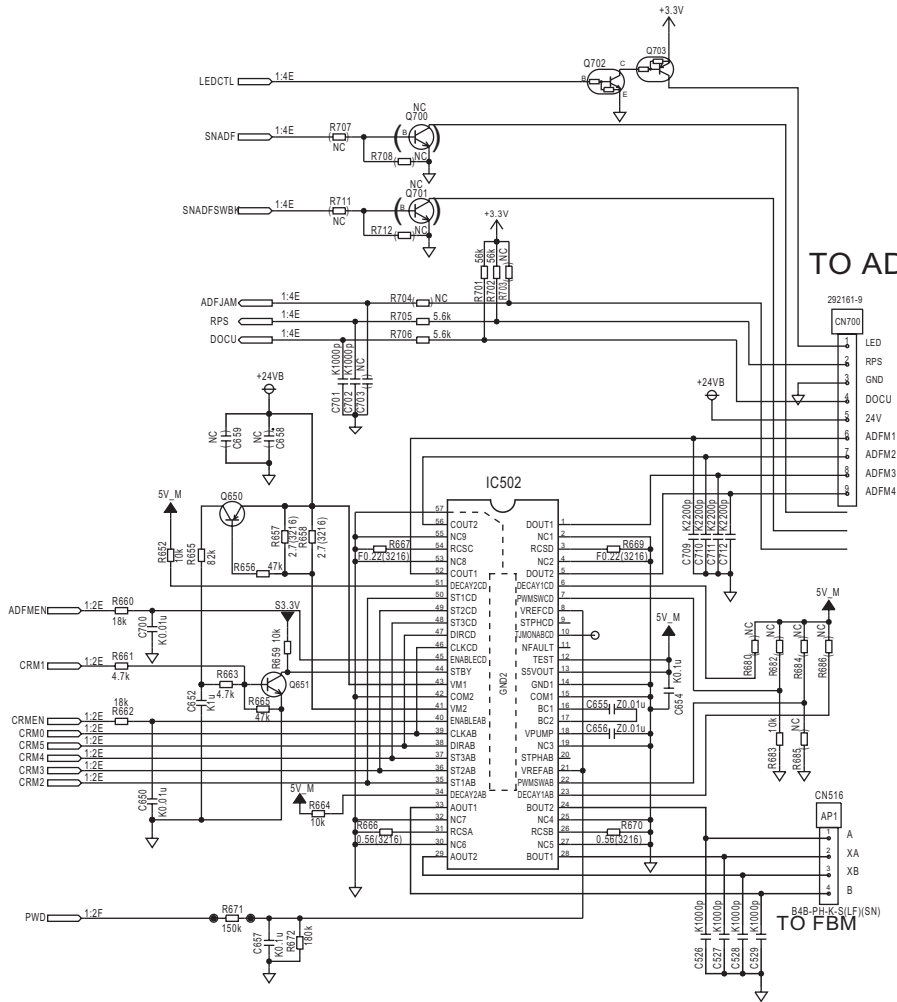

TO ADF Block

TO FBM

KX-MB2230EU MAIN BOARD (No.4) (2/2)

16.2.5. Main Board(5)

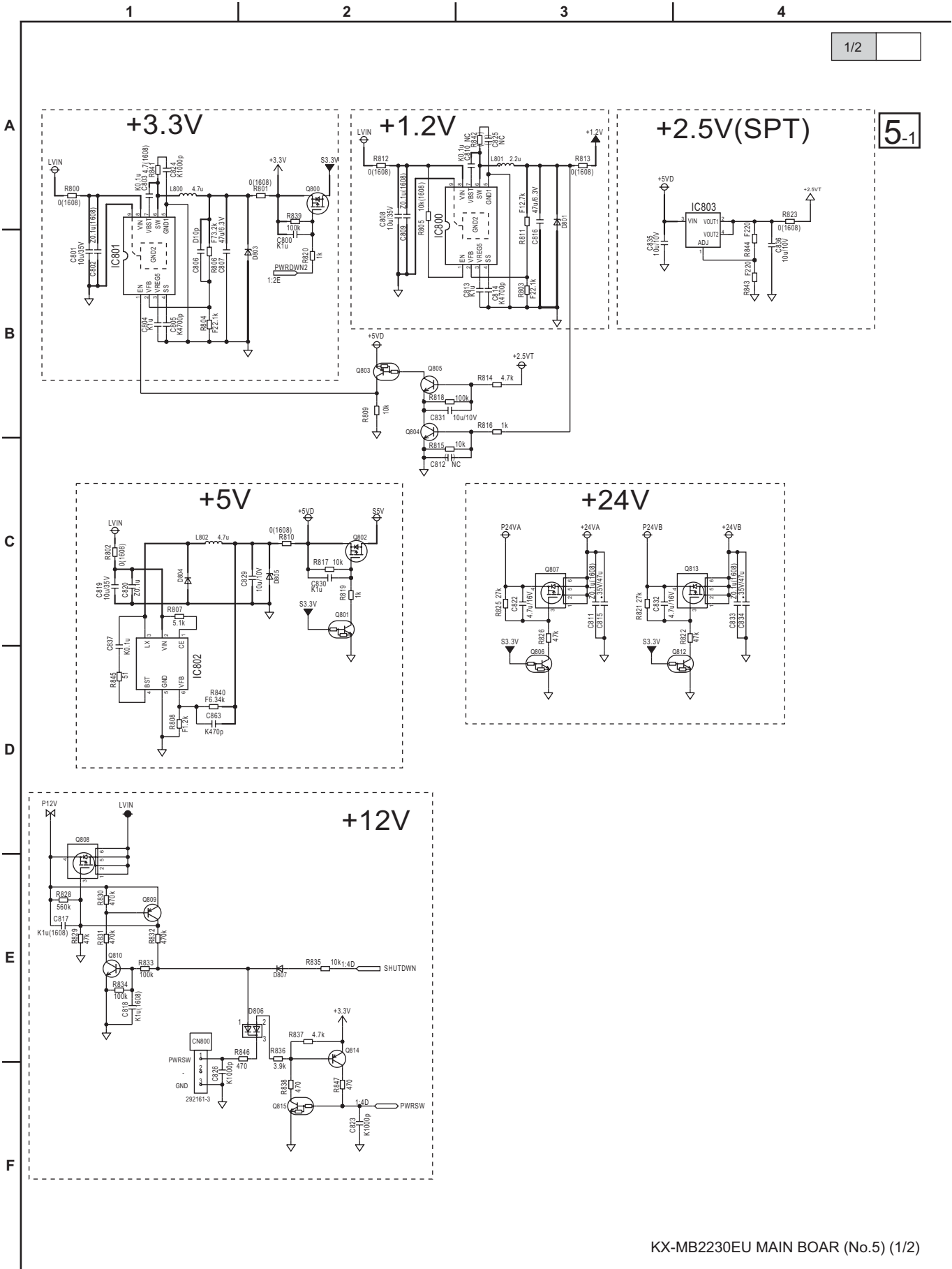

KX-MB2230EU MAIN BOAR (No.5) (1/2)

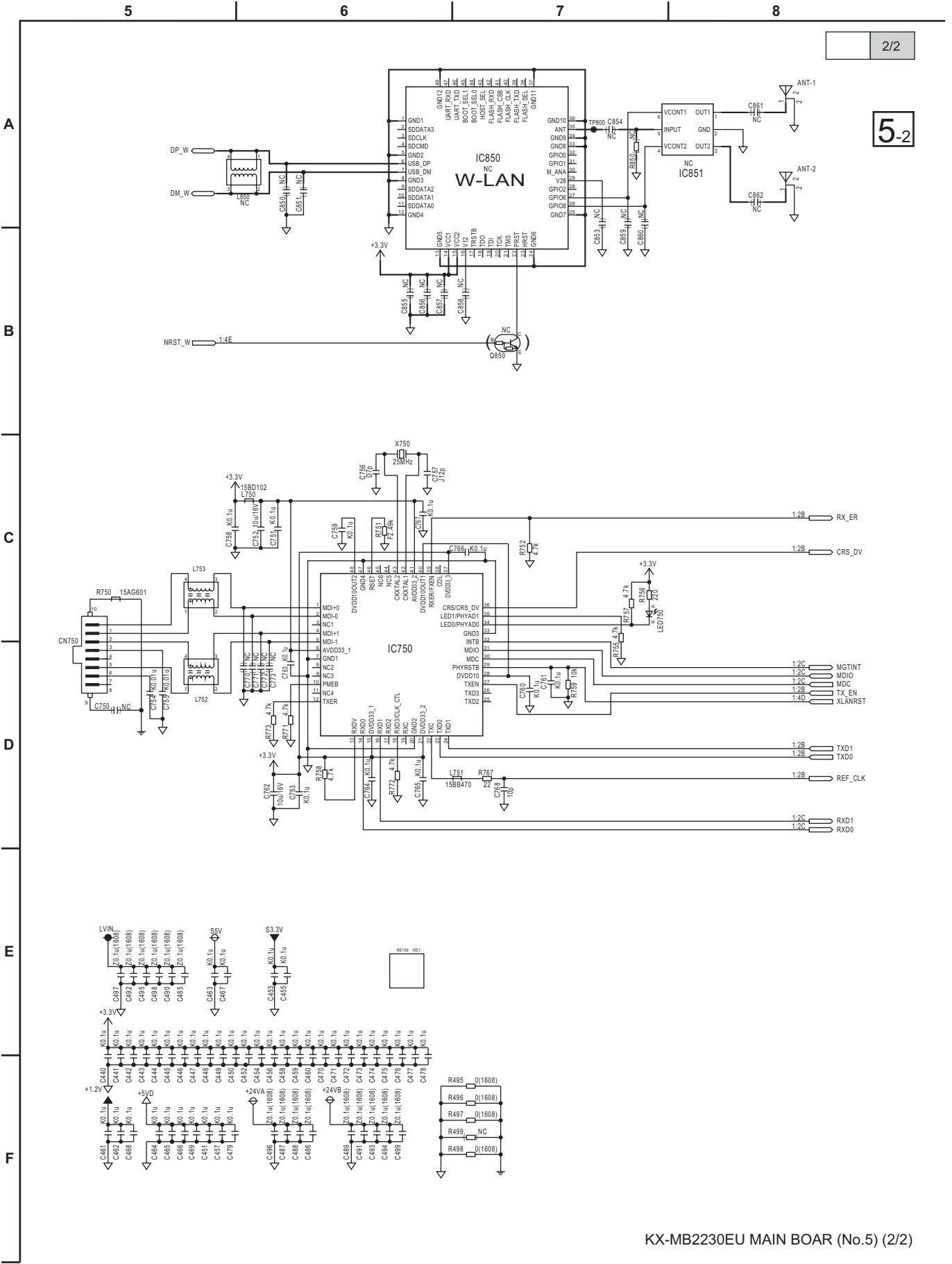

KX-MB2230EU MAIN BOAR (No.5) (2/2)

16.2.6. Main Board(6)

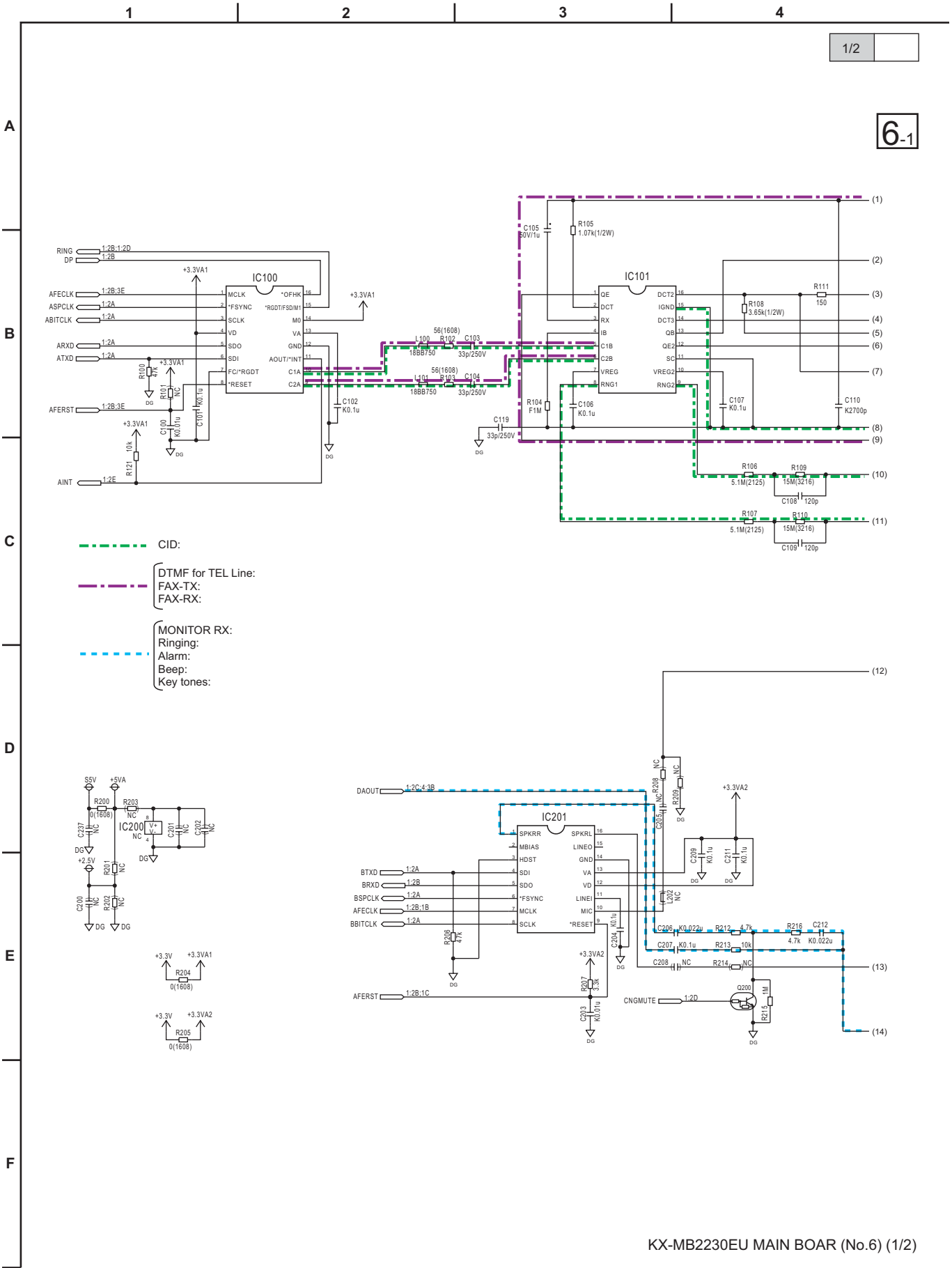

KX-MB2230EU MAIN BOARD (No.6) (1/2)

6-2

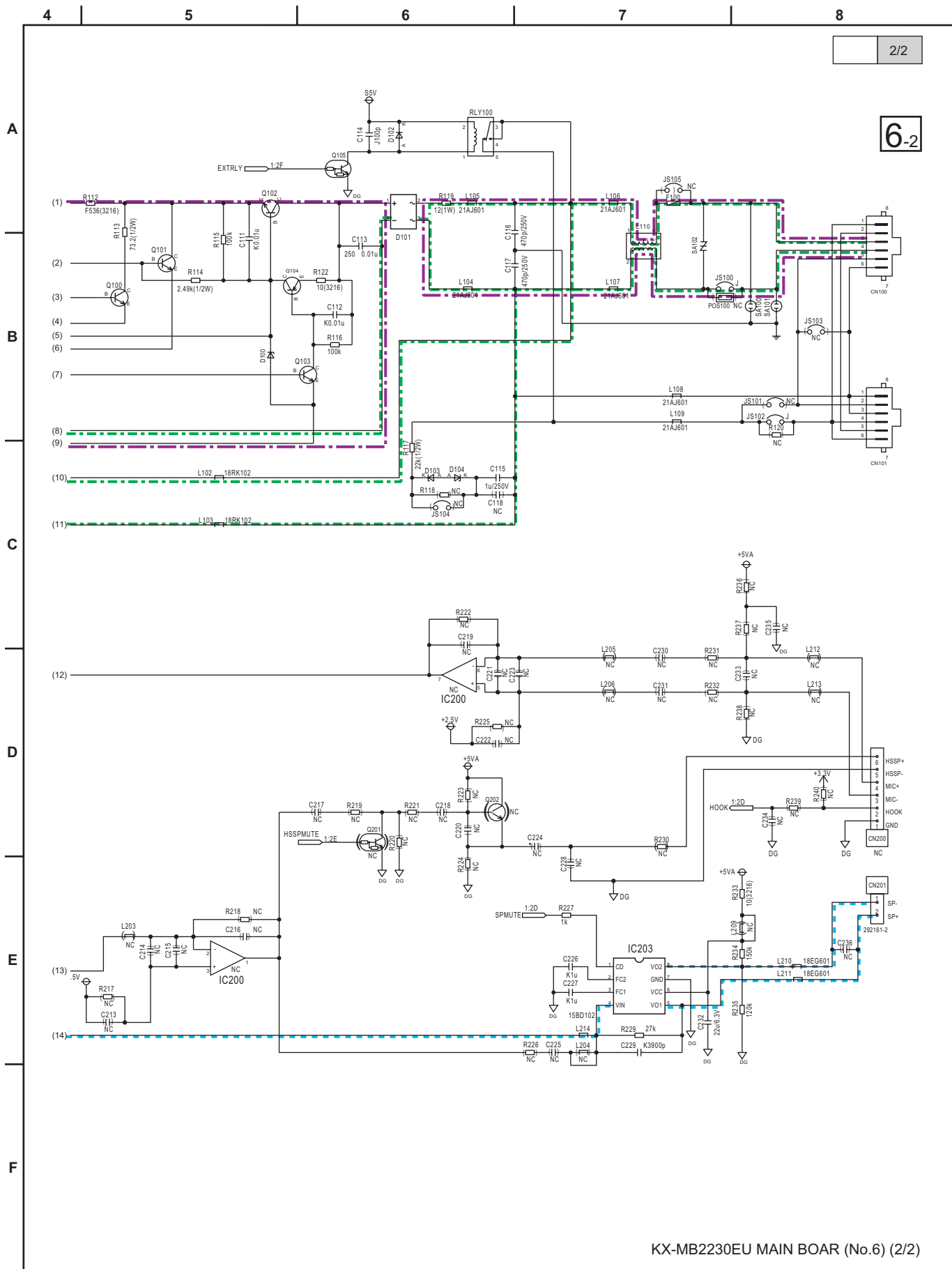

KX-MB2230EU MAIN BOAR (No.6) (2/2)

16.3. Main Board (KX-MB2270)

16.3.1. Main Board(1)

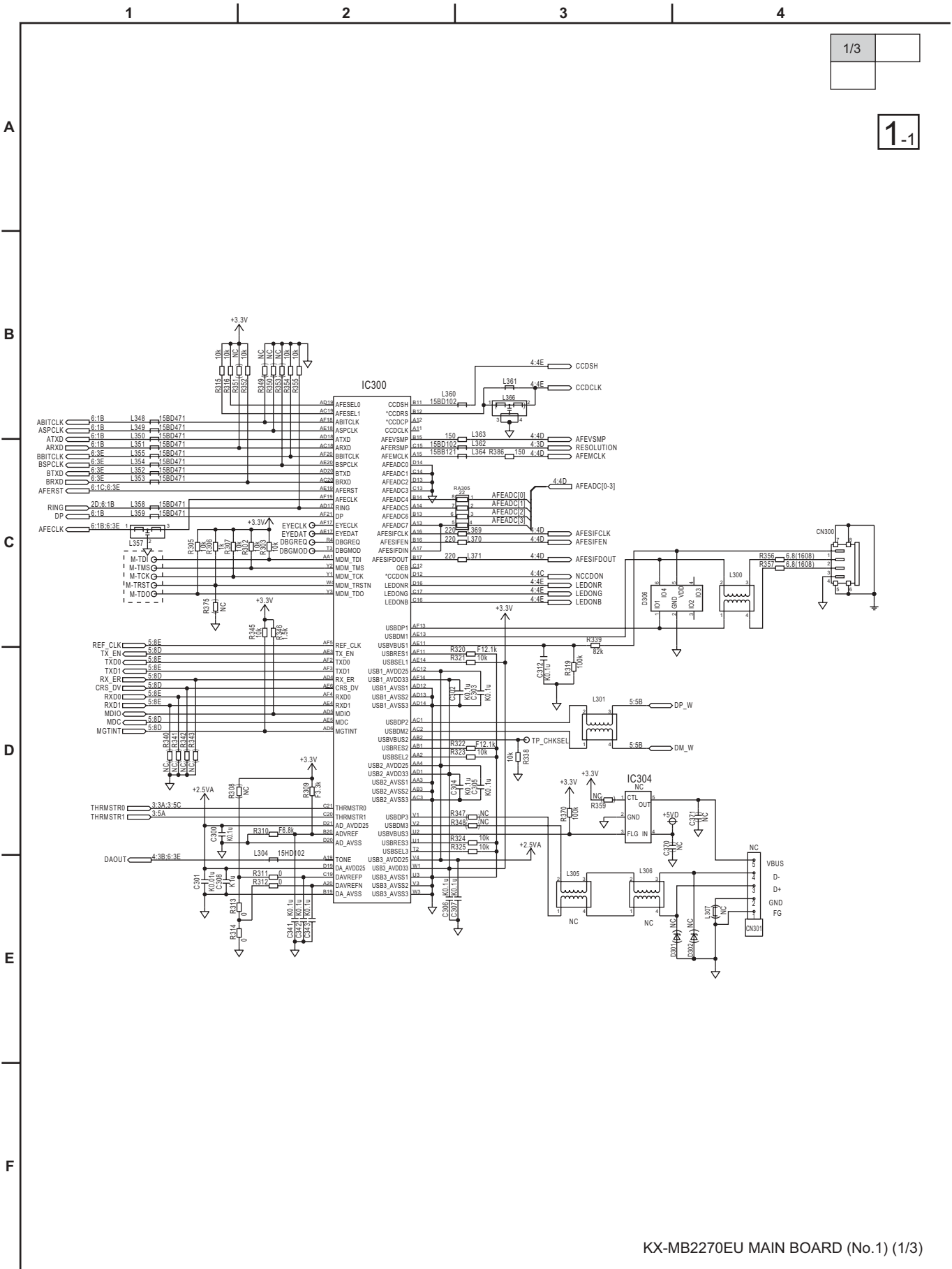

KX-MB2270EU MAIN BOARD (No.1) (1/3)

5

6

7

8

2/3

1-2

A

B

C

D

E

F

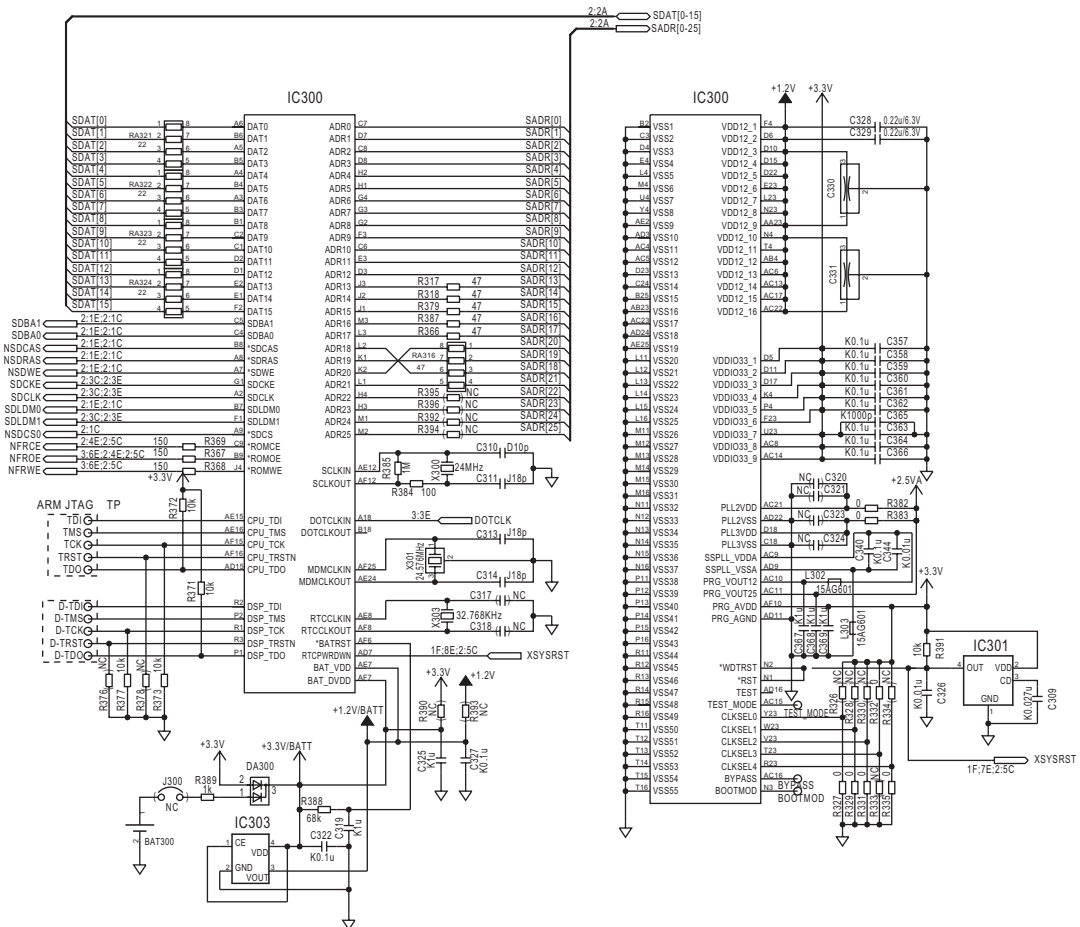

KX-MB2270EU MAIN BOARD (No.1) (2/3)

H

I

J

K

L

M

To IC chip

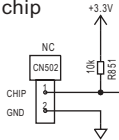

I2C Expander

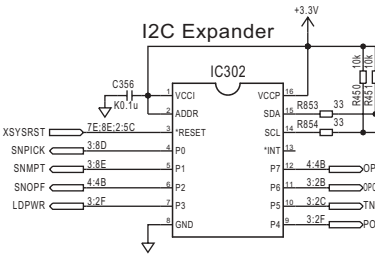

IC300

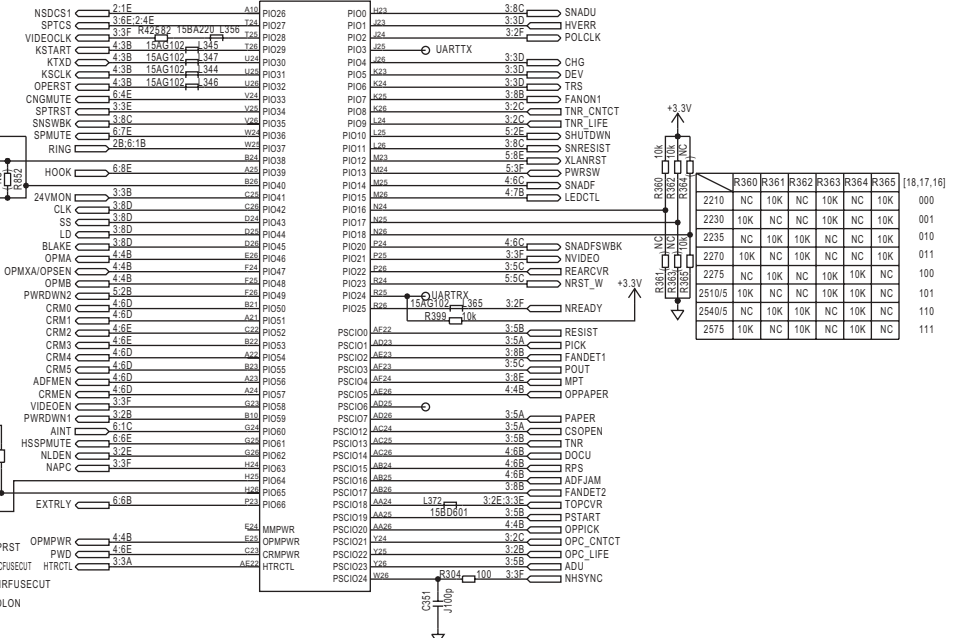

Memo

16.3.2. Main Board(2)

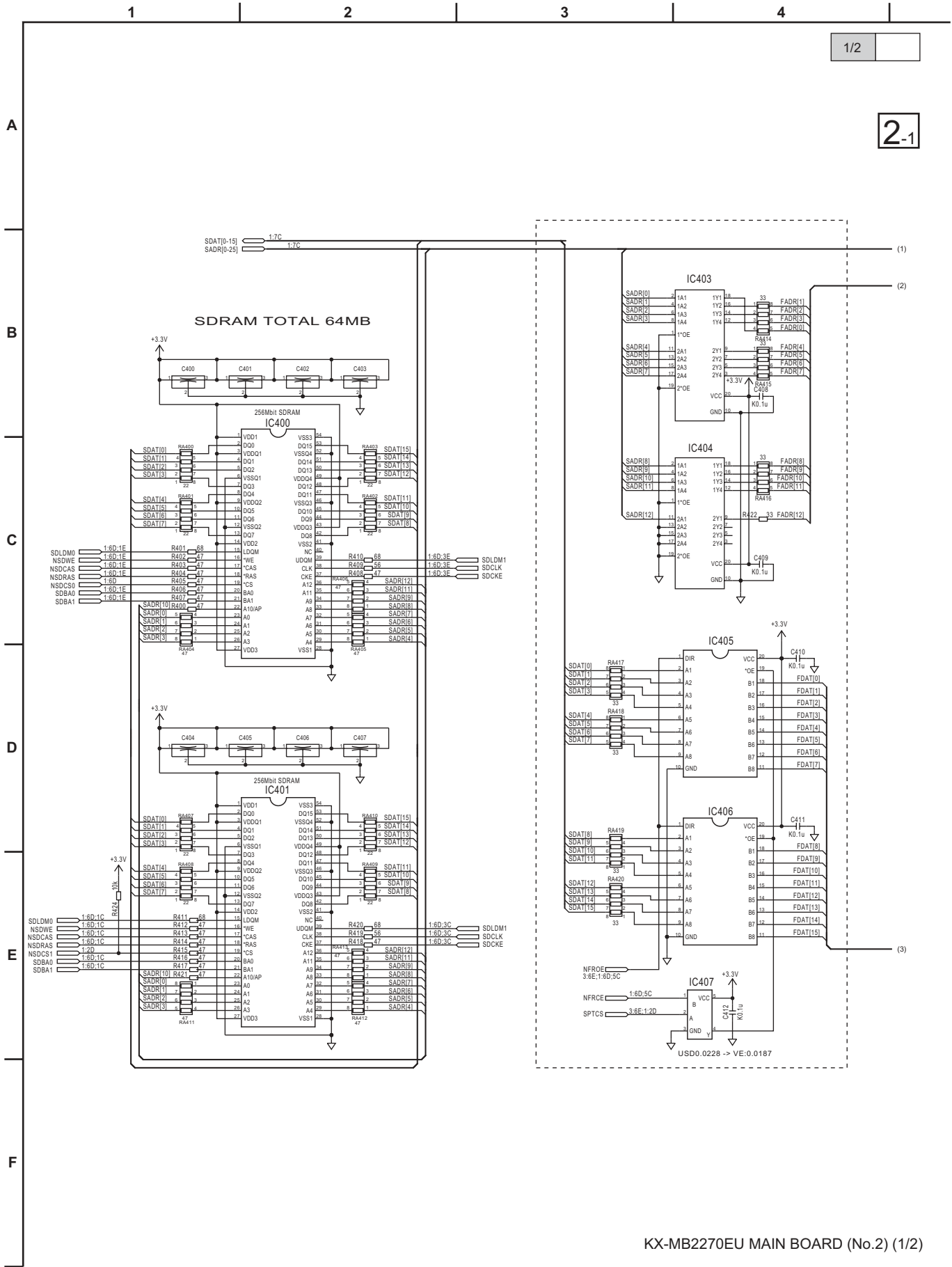

1/2

2-1

KX-MB2270EU MAIN BOARD (No.2) (1/2)

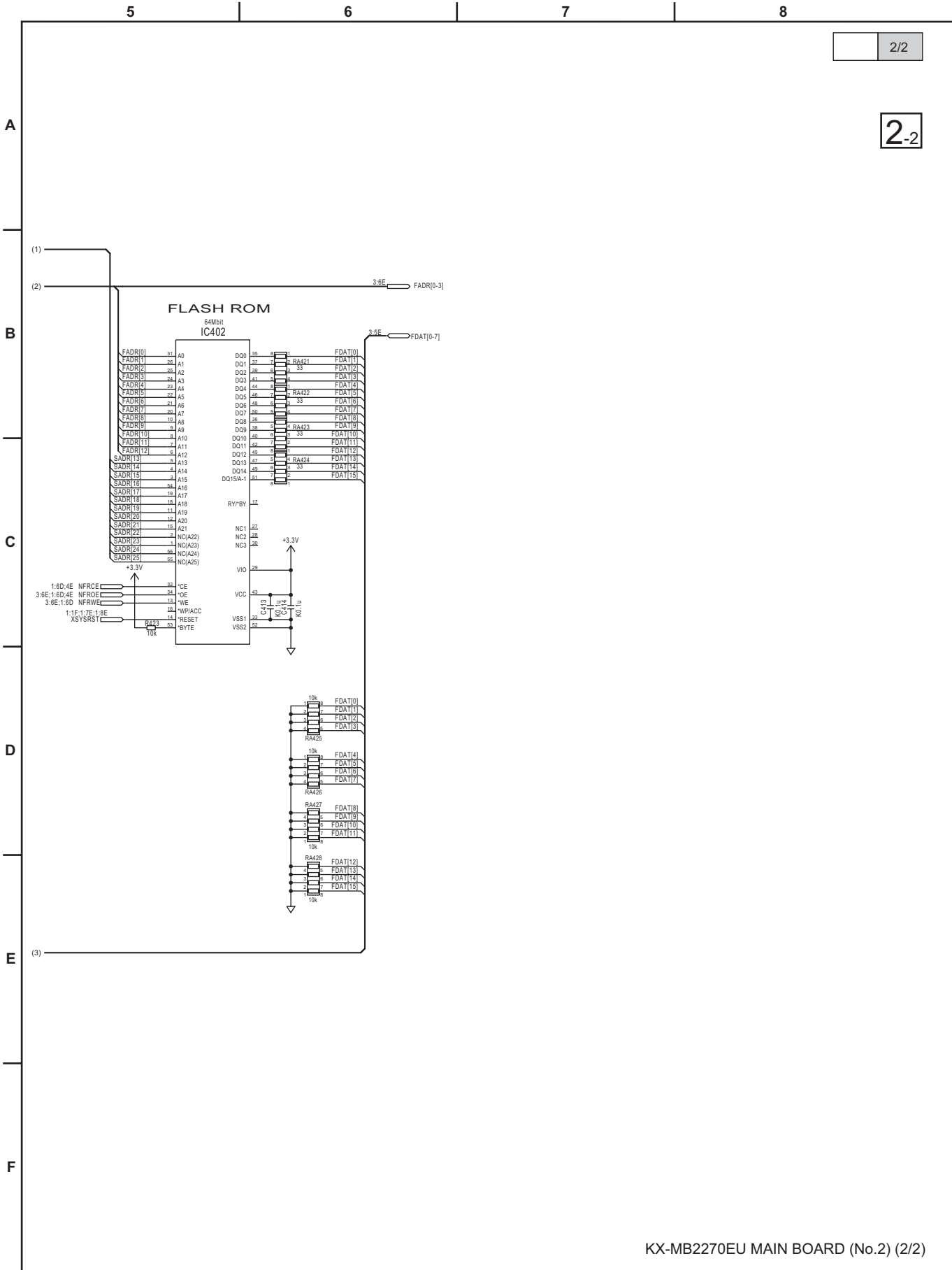

KX-MB2270EU MAIN BOARD (No.2) (2/2)

5

6

7

8

A

B

C

D

E

F

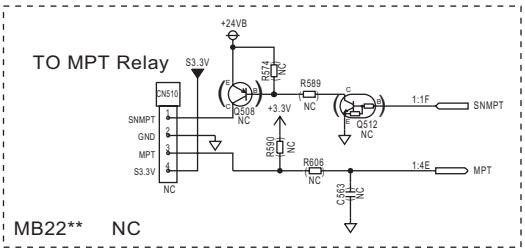
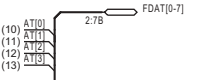
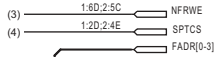
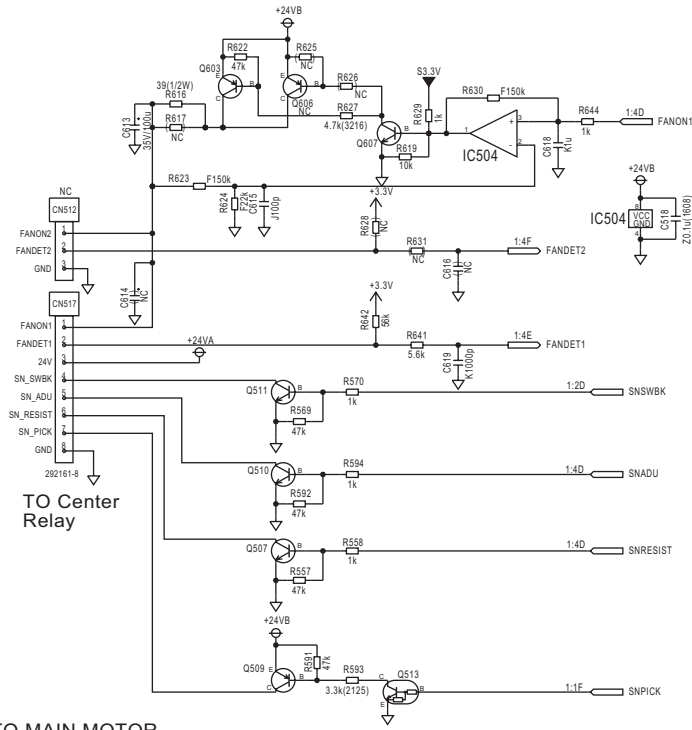

KX-MB2270EU MAIN BOARD (No.3) (2/2)

16.3.4. Main Board(4)

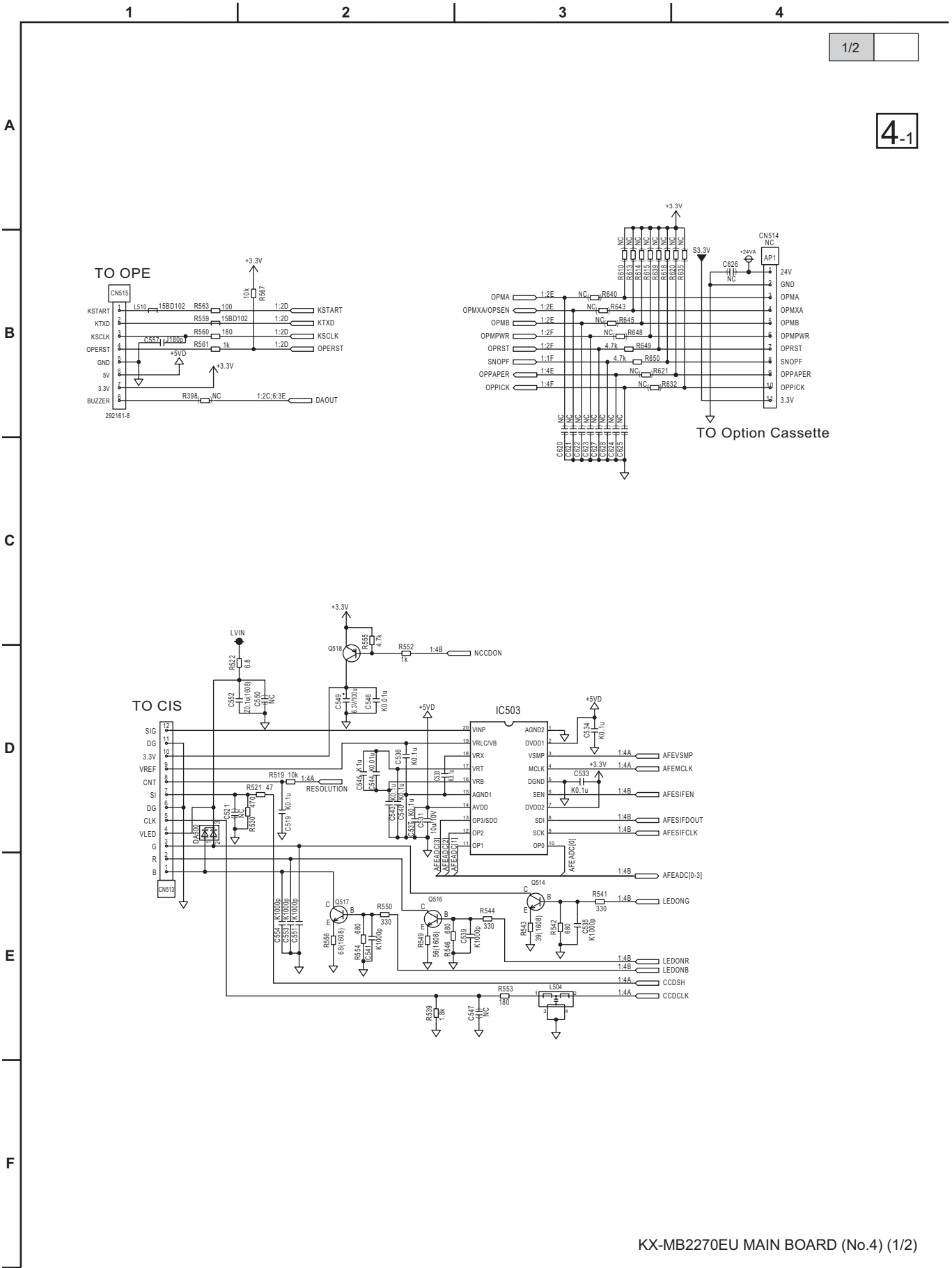

KX-MB2270EU MAIN BOARD (No.4) (1/2)

16.3.5. Main Board(5)

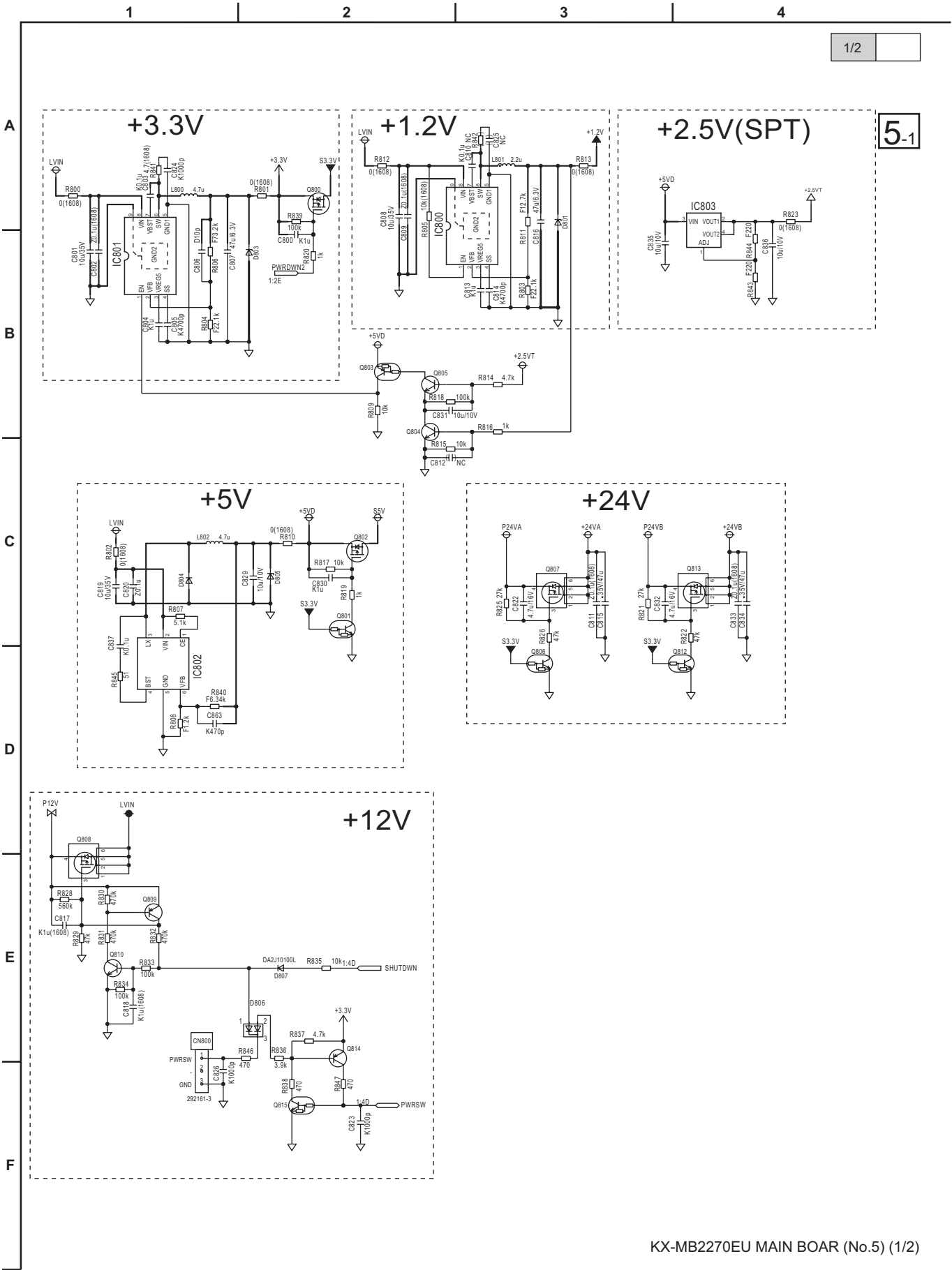

KX-MB2270EU MAIN BOAR (No.5) (1/2)

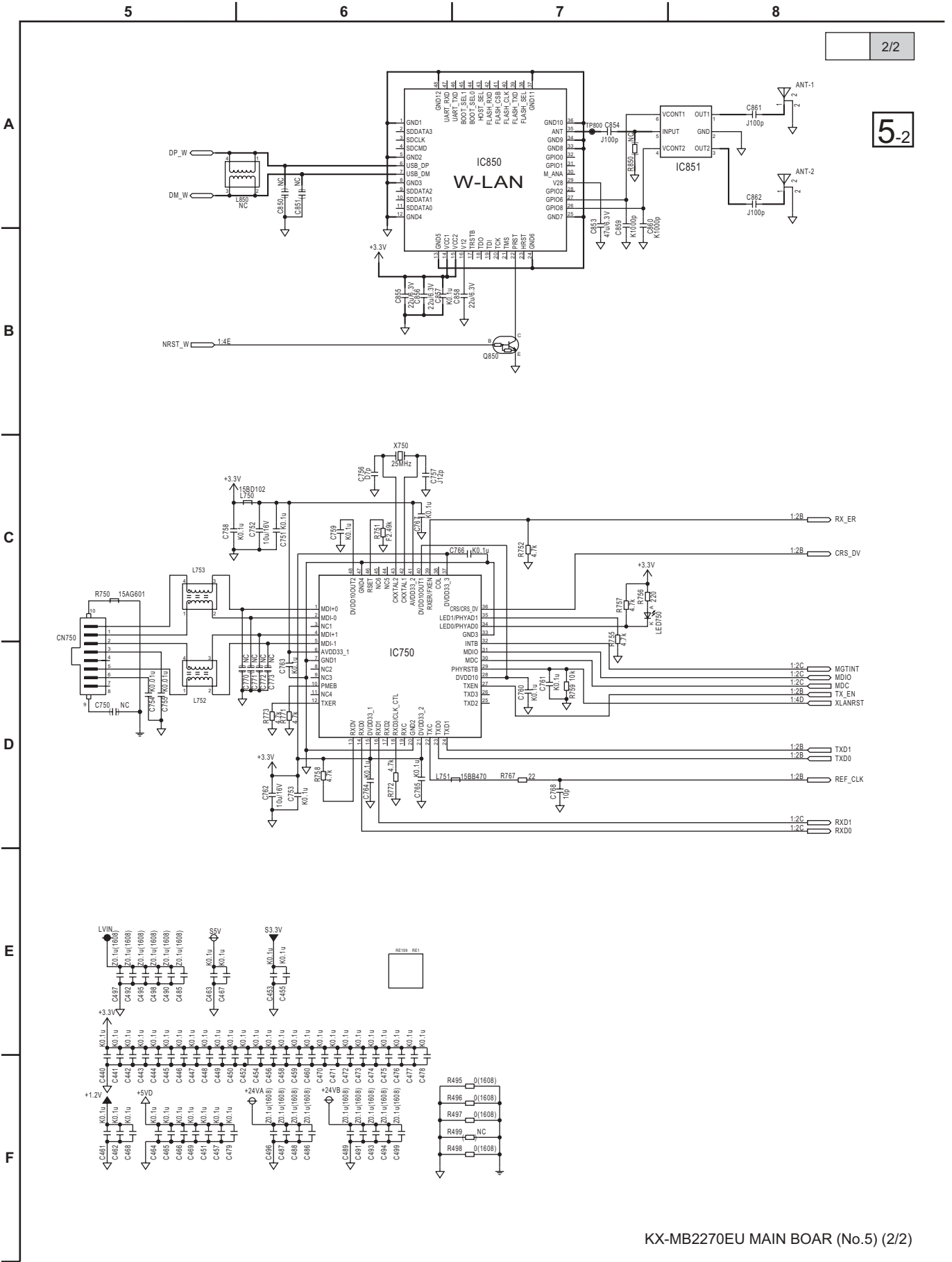

KX-MB2270EU MAIN BOAR (No.5) (2/2)

16.3.6. Main Board(6)

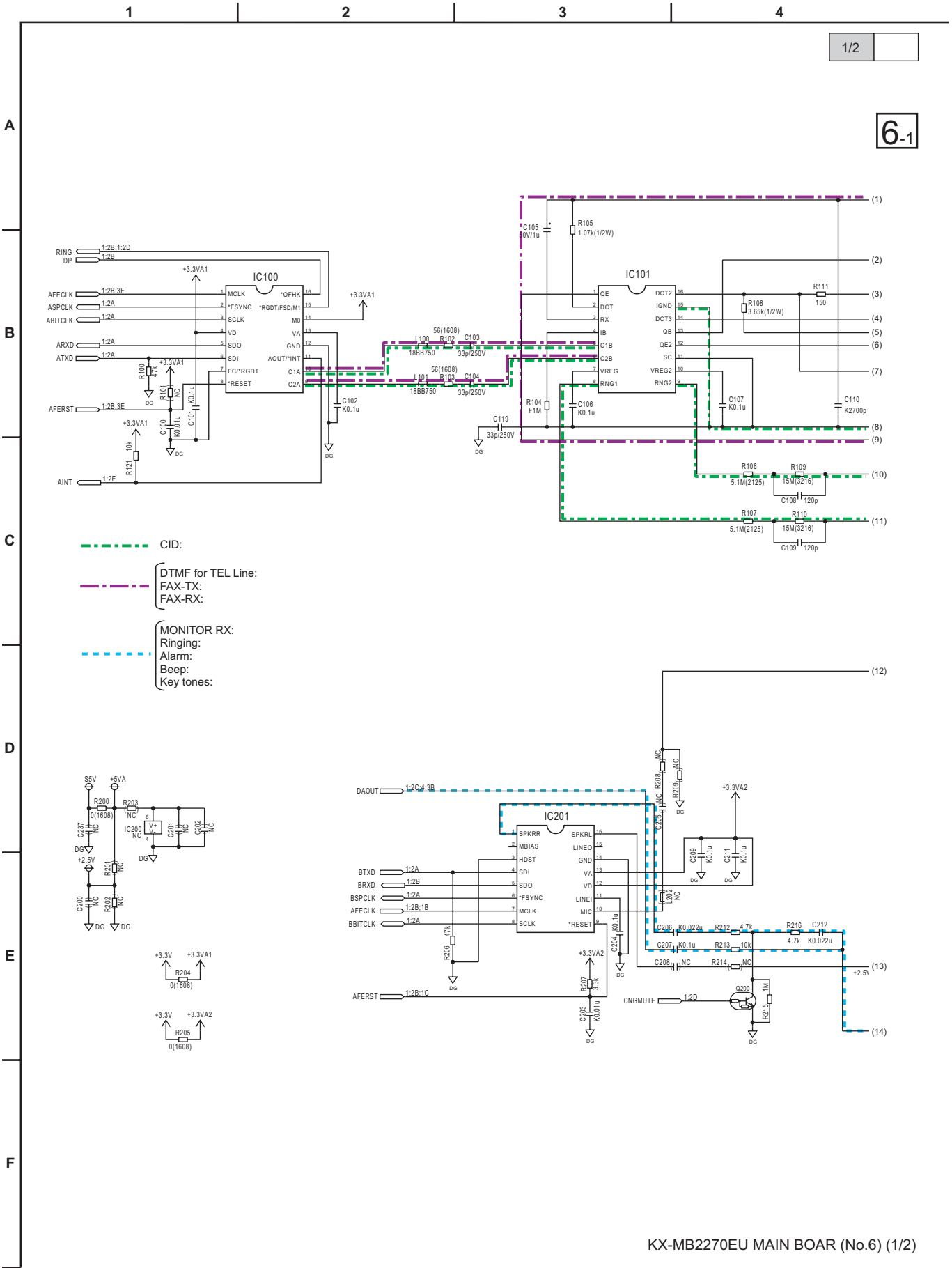

KX-MB2270EU MAIN BOARD (No.6) (1/2)

6-2

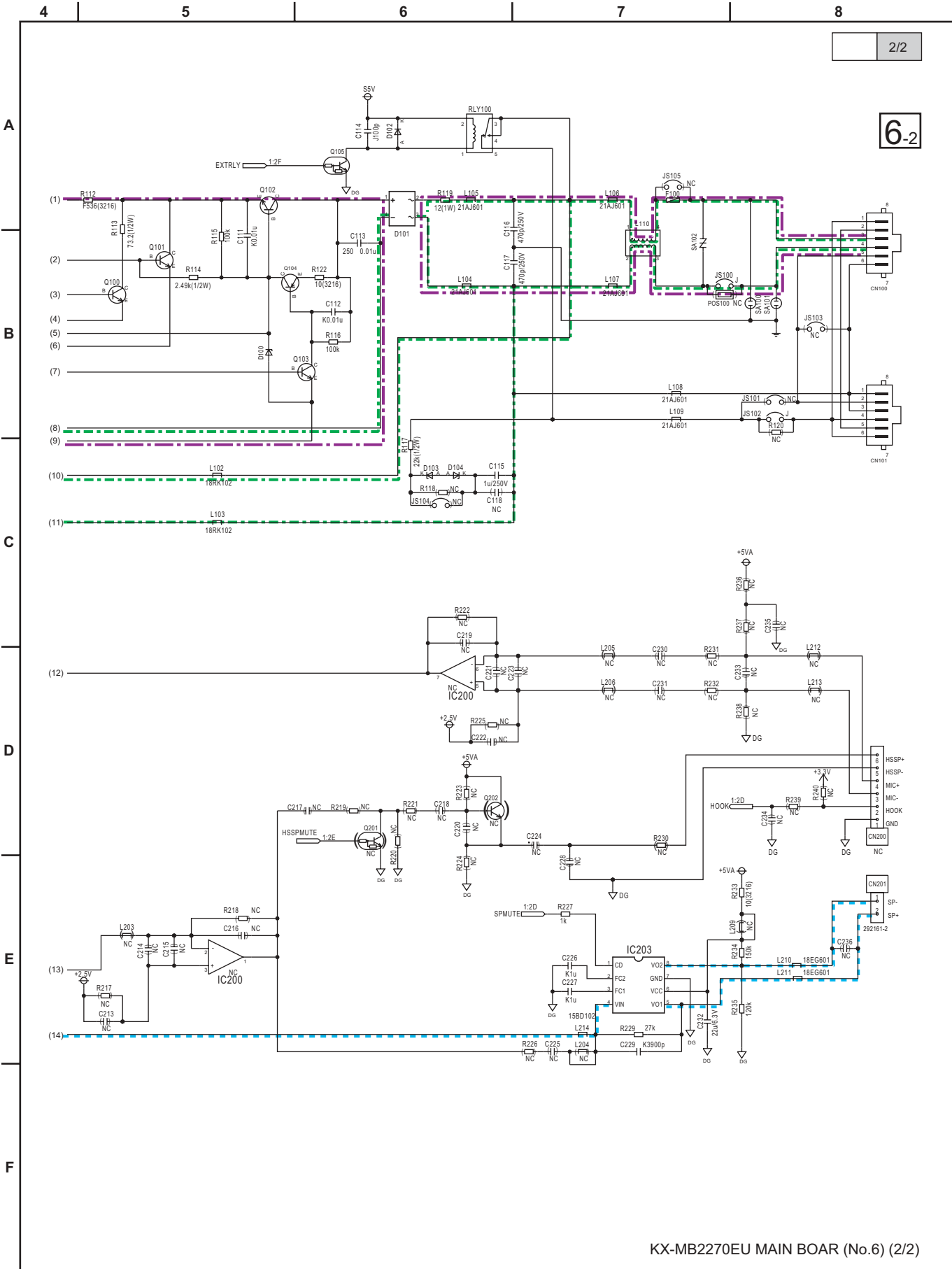

KX-MB2270EU MAIN BOAR (No.6) (2/2)

16.4. Main Board (KX-MB2515)

16.4.1. Main Board(1)

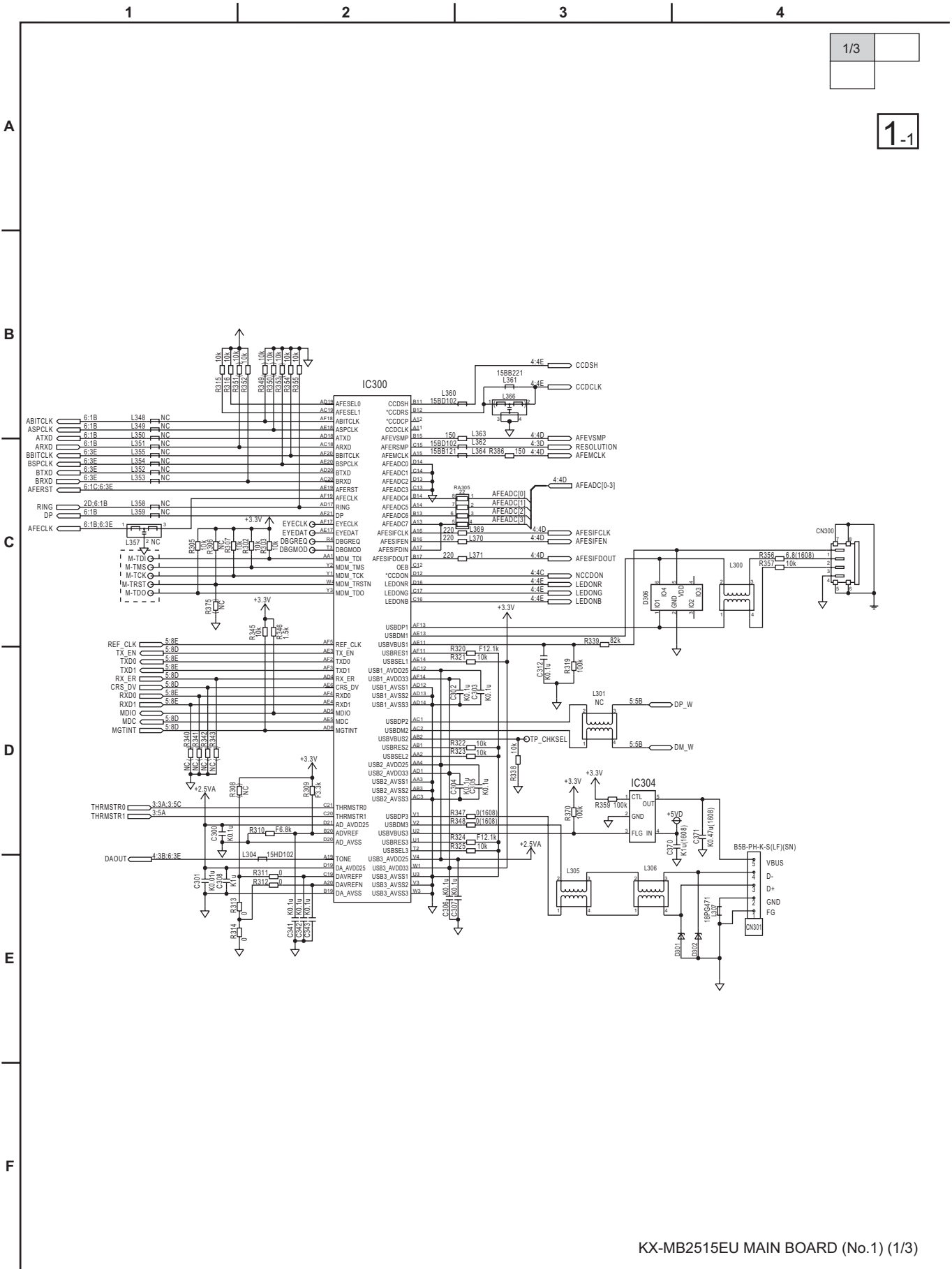

KX-MB2515EU MAIN BOARD (No.1) (1/3)

5

6

7

8

2/3

1-2

A

B

C

D

E

F

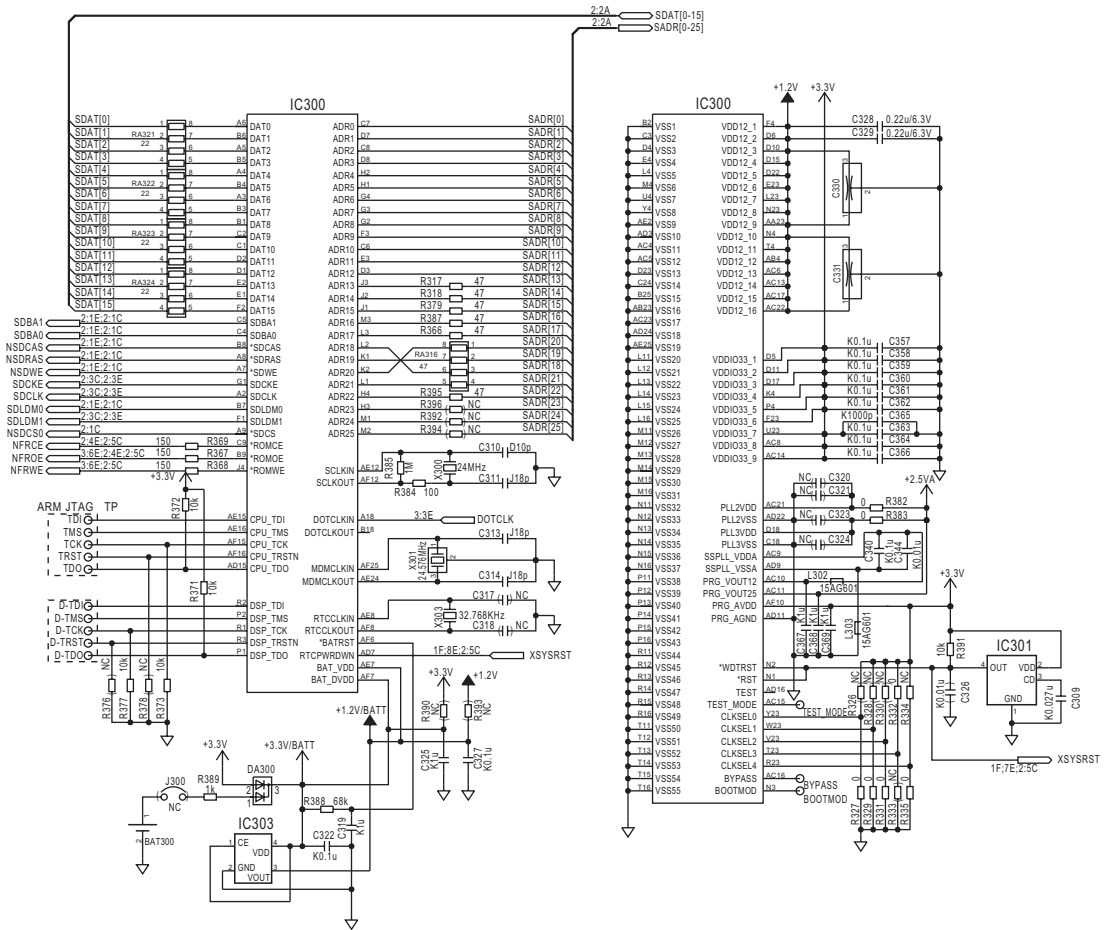

KX-MB2515EU MAIN BOARD (No.1) (2/3)

H
I
J
K
L
M

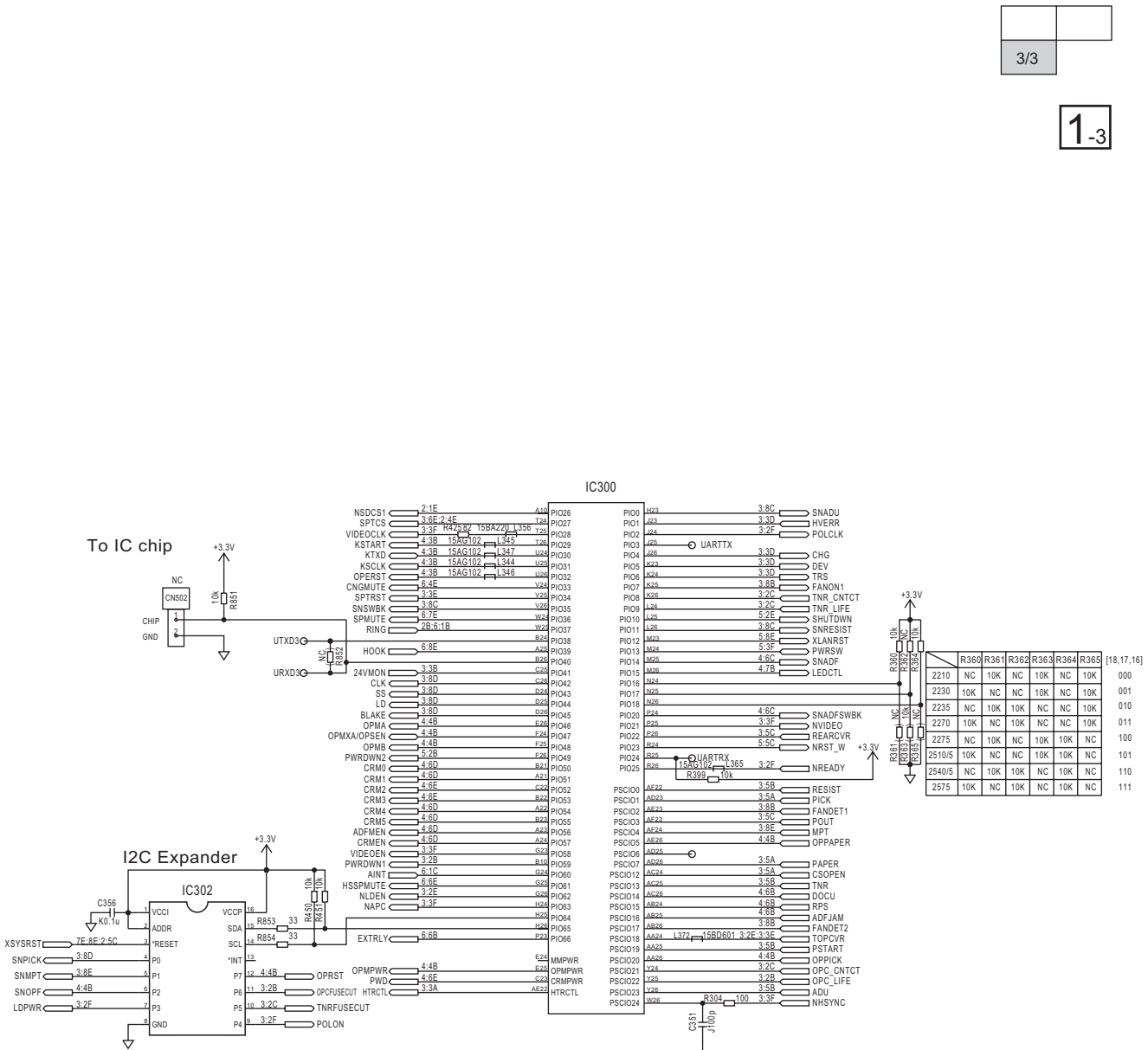

KX-MB2515EU MAIN BOARD (No.1) (3/3)

Memo

16.4.2. Main Board(2)

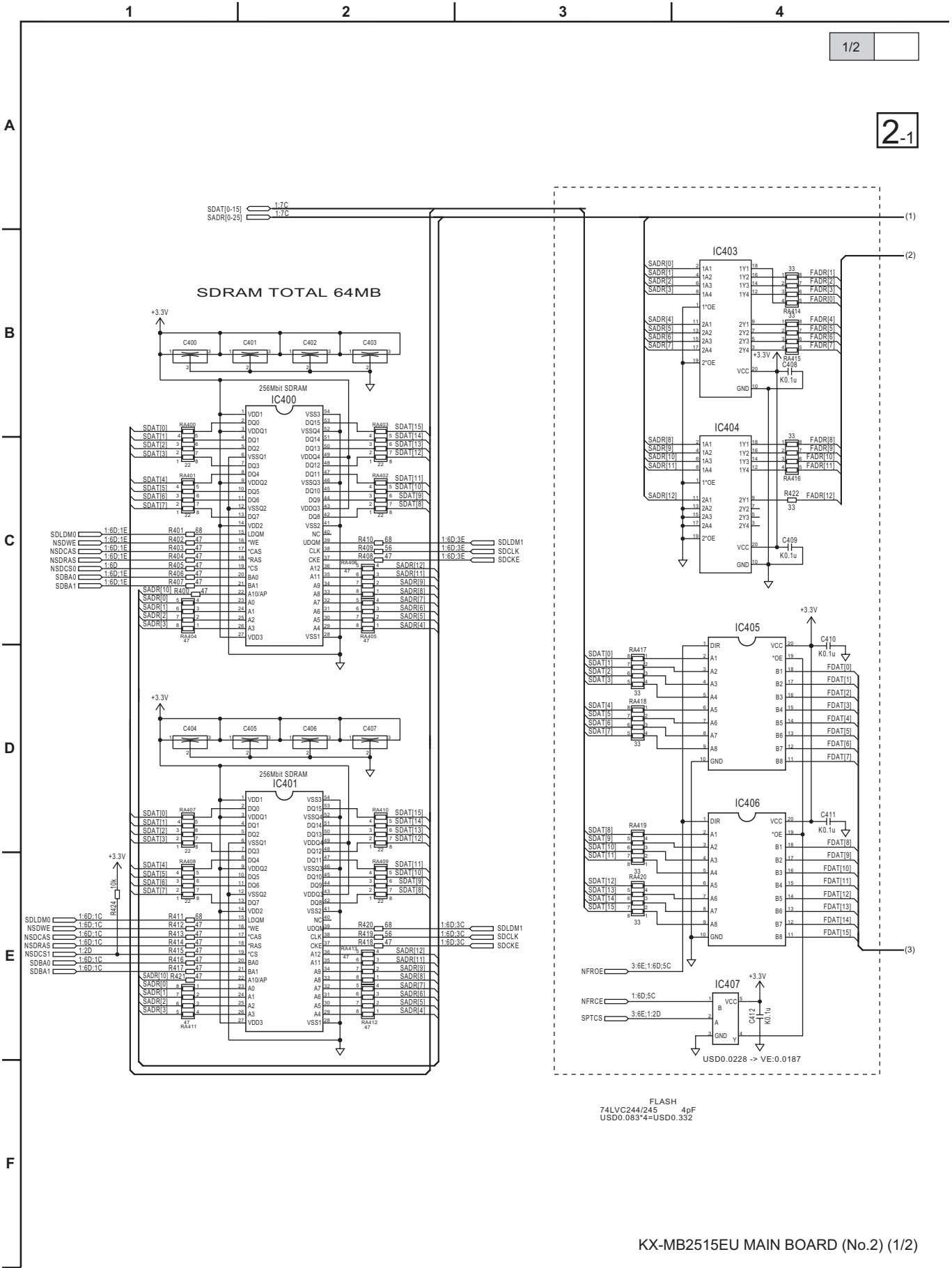

4 | 5 | 6 | 7 | 8

2/2

2-2

A

B

C

D

E

F

(1)
(2)

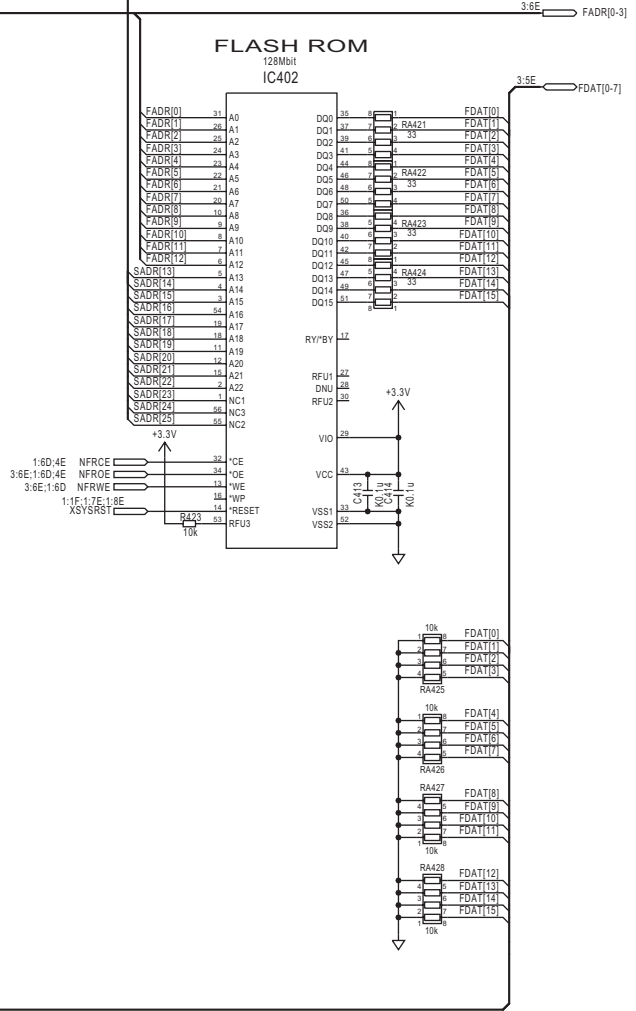

16.4.3. Main Board(3)

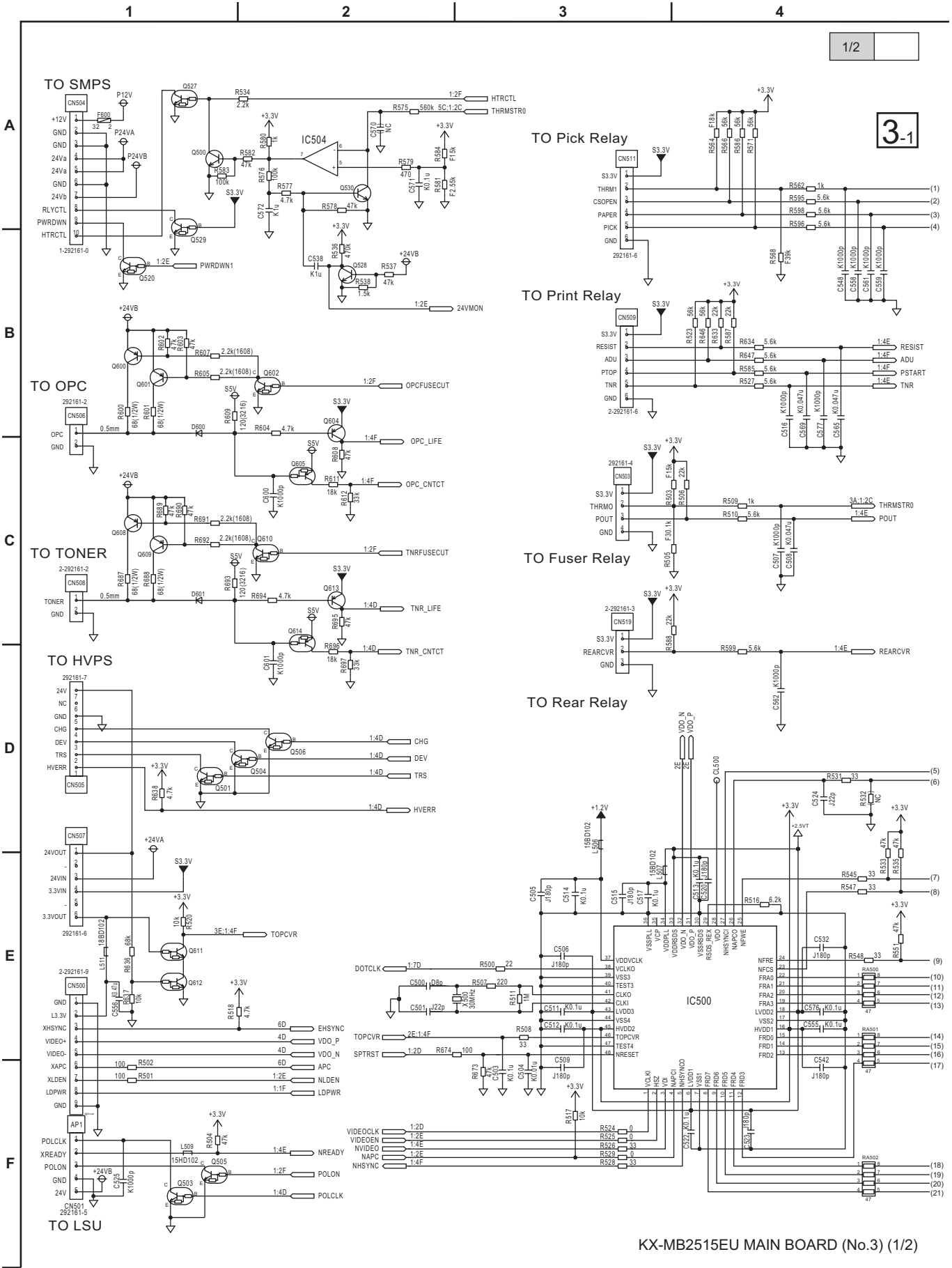

KX-MB2515EU MAIN BOARD (No.3) (1/2)

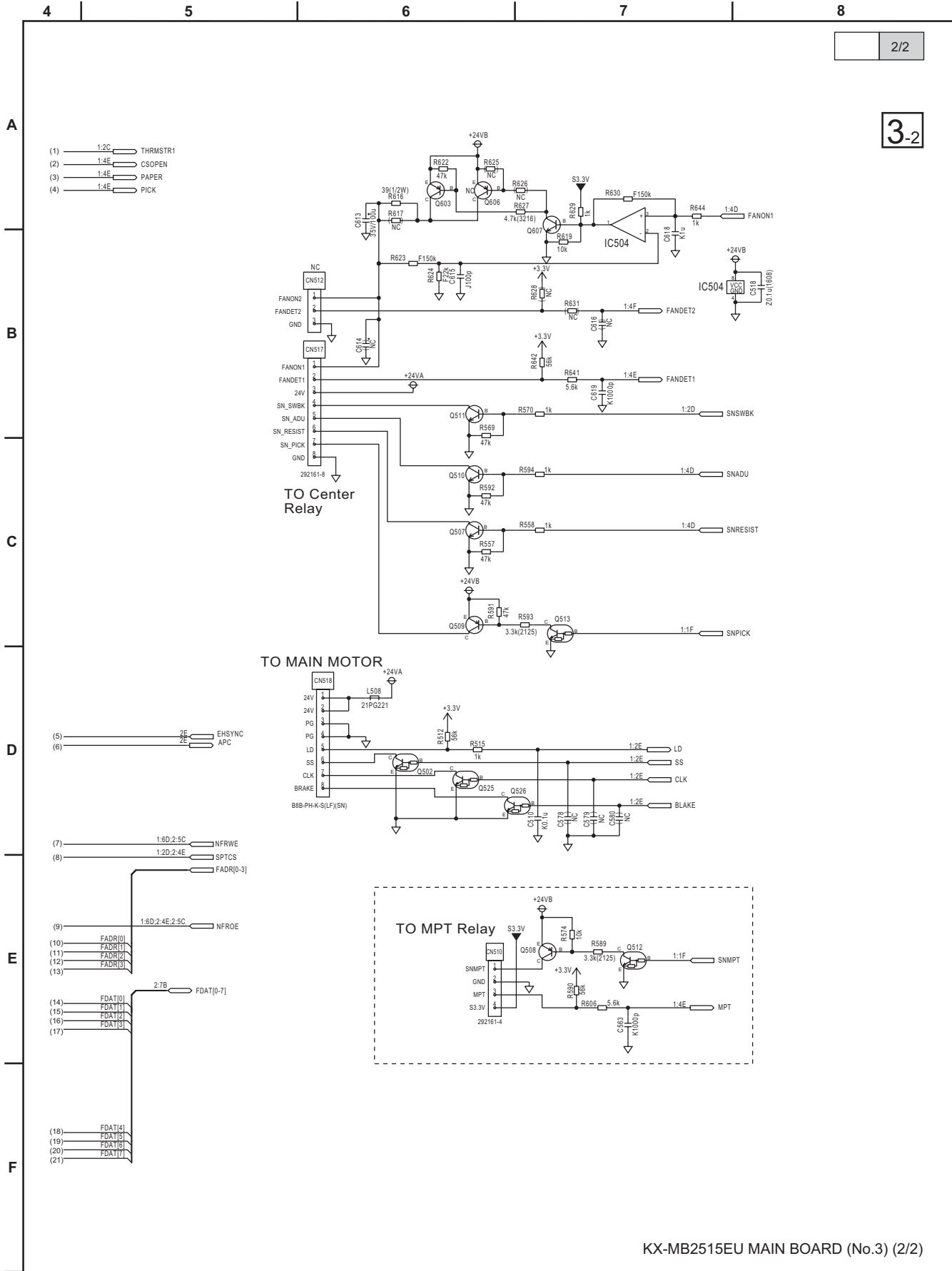

KX-MB2515EU MAIN BOARD (No.3) (2/2)

16.4.4. Main Board(4)

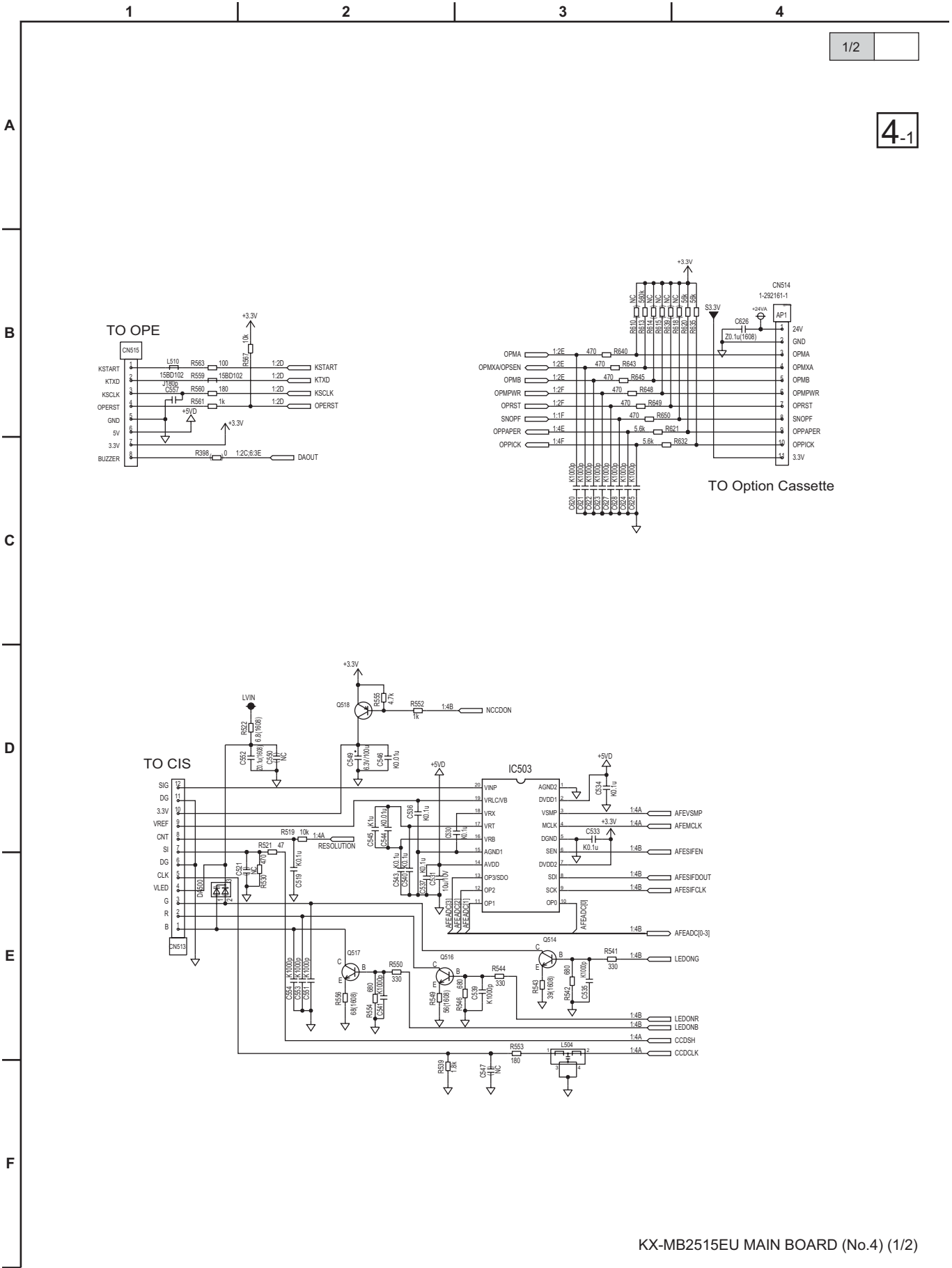

1/2

4.1

KX-MB2515EU MAIN BOARD (No.4) (1/2)

5

6

7

8

2/2

4-2

A

B

C

D

E

F

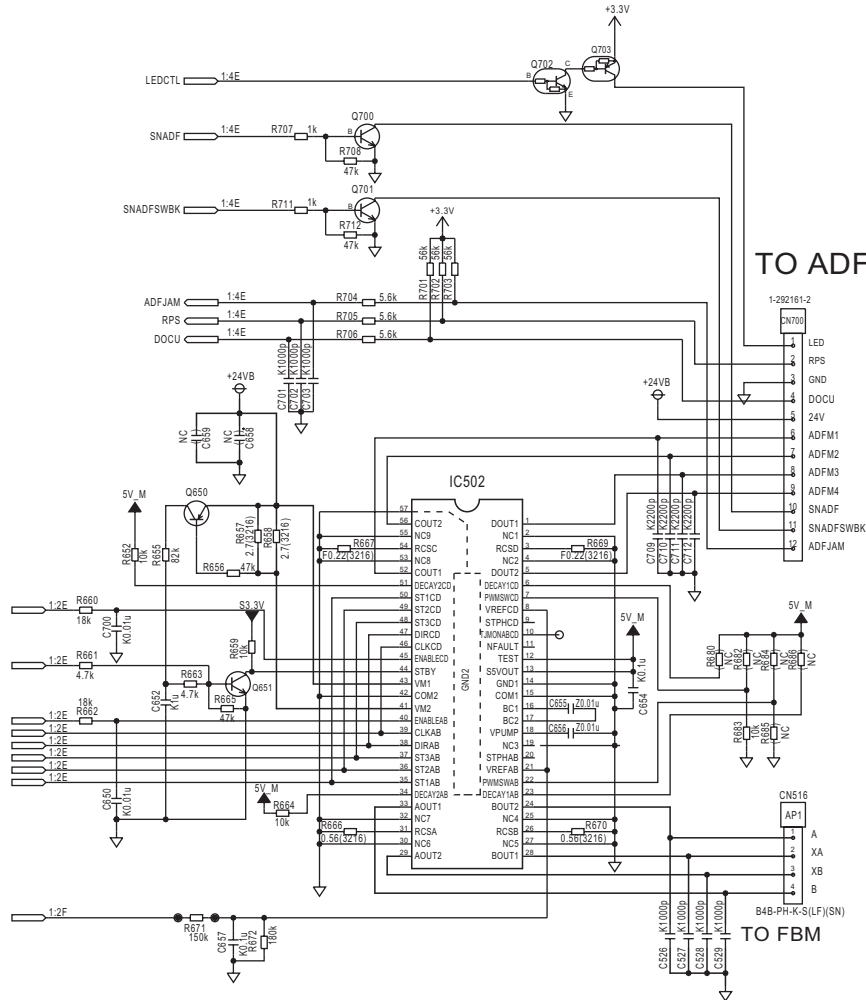

KX-MB2515EU MAIN BOARD (No.4) (2/2)

16.4.5. Main Board(5)

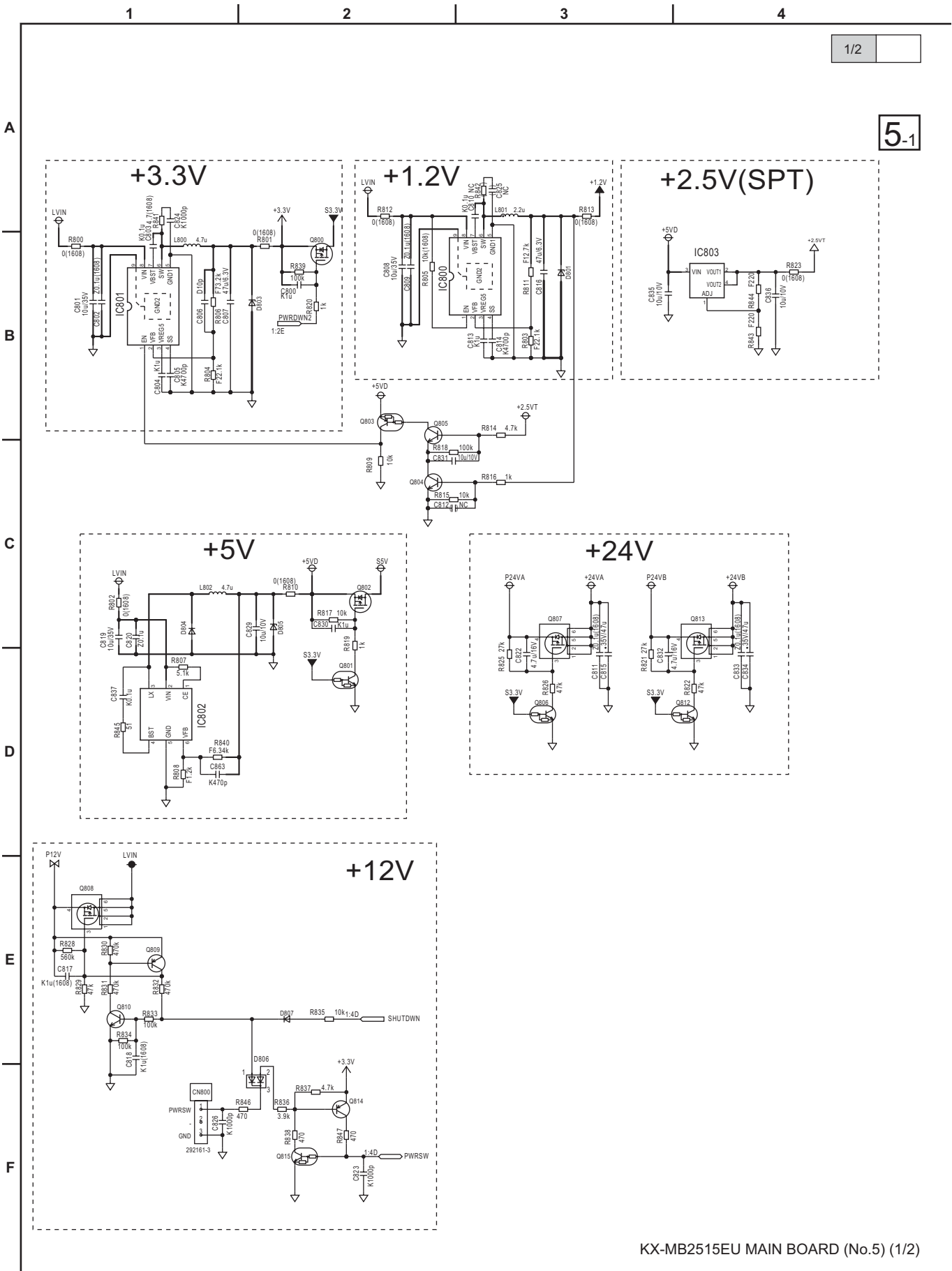

KX-MB2515EU MAIN BOARD (No.5) (1/2)

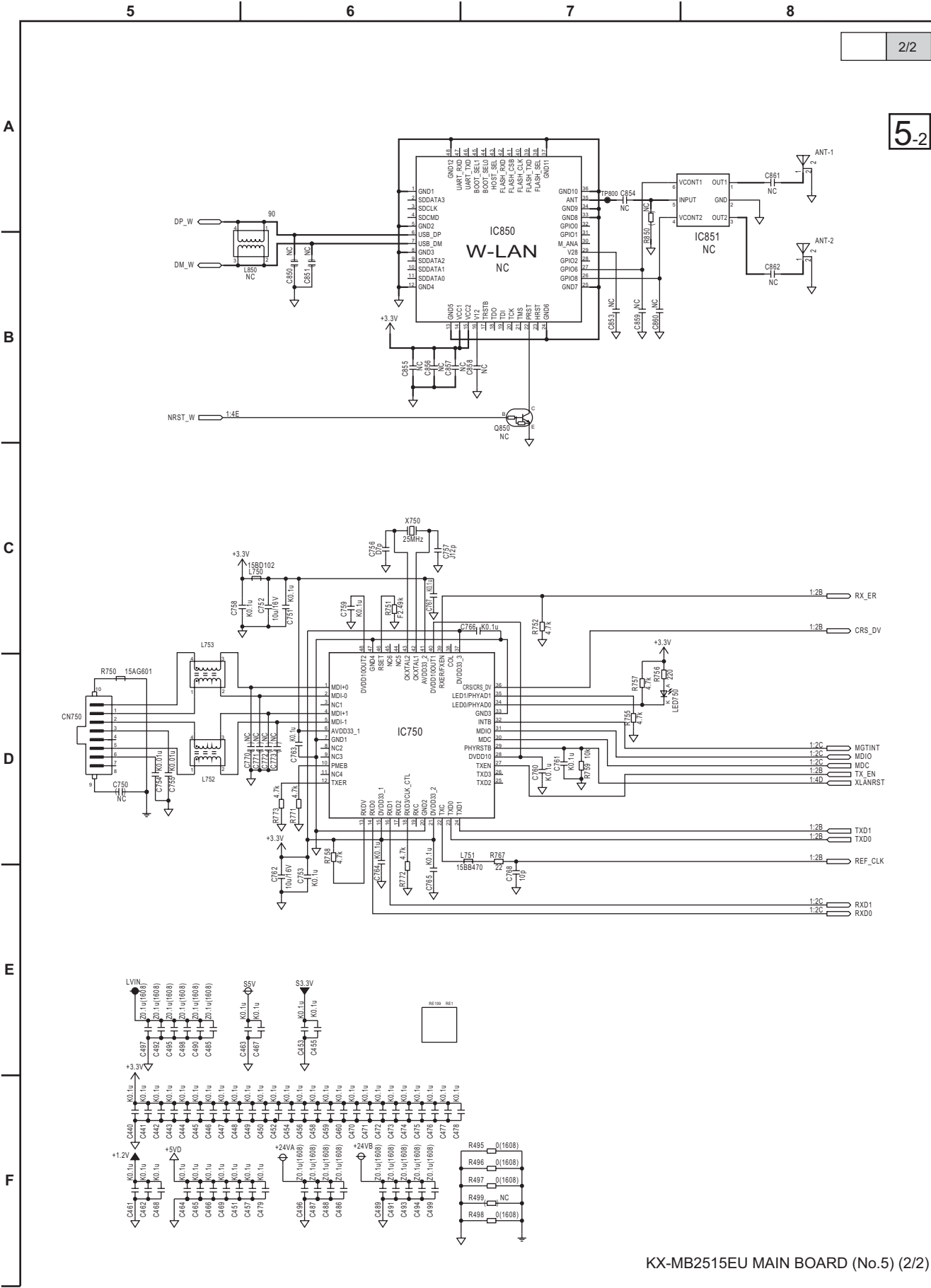

KX-MB2515EU MAIN BOARD (No.5) (2/2)

16.4.6. Main Board(6)

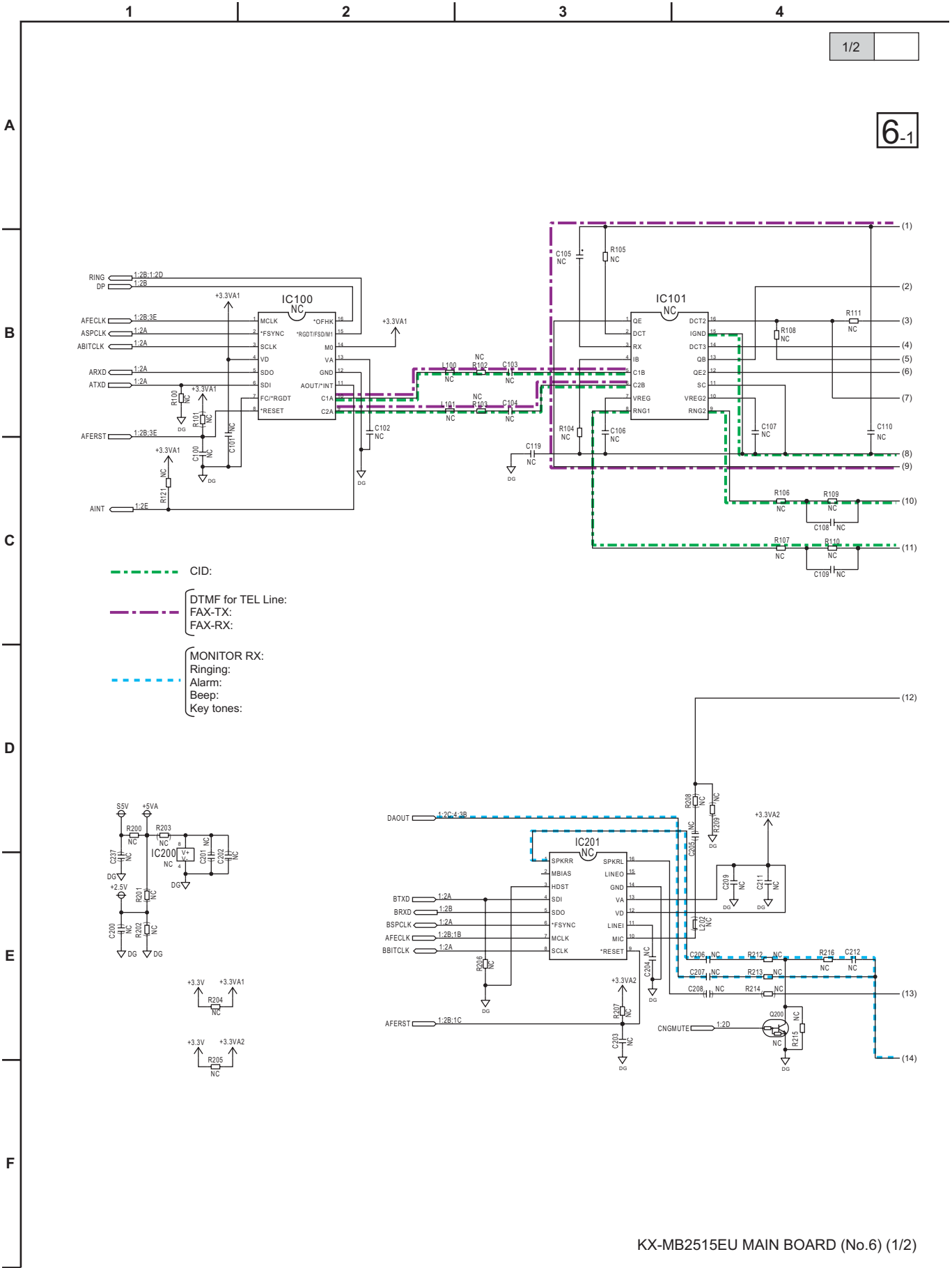

KX-MB2515EU MAIN BOARD (No.6) (1/2)

16.5. Main Board (KX-MB2545)

16.5.1. Main Board(1)

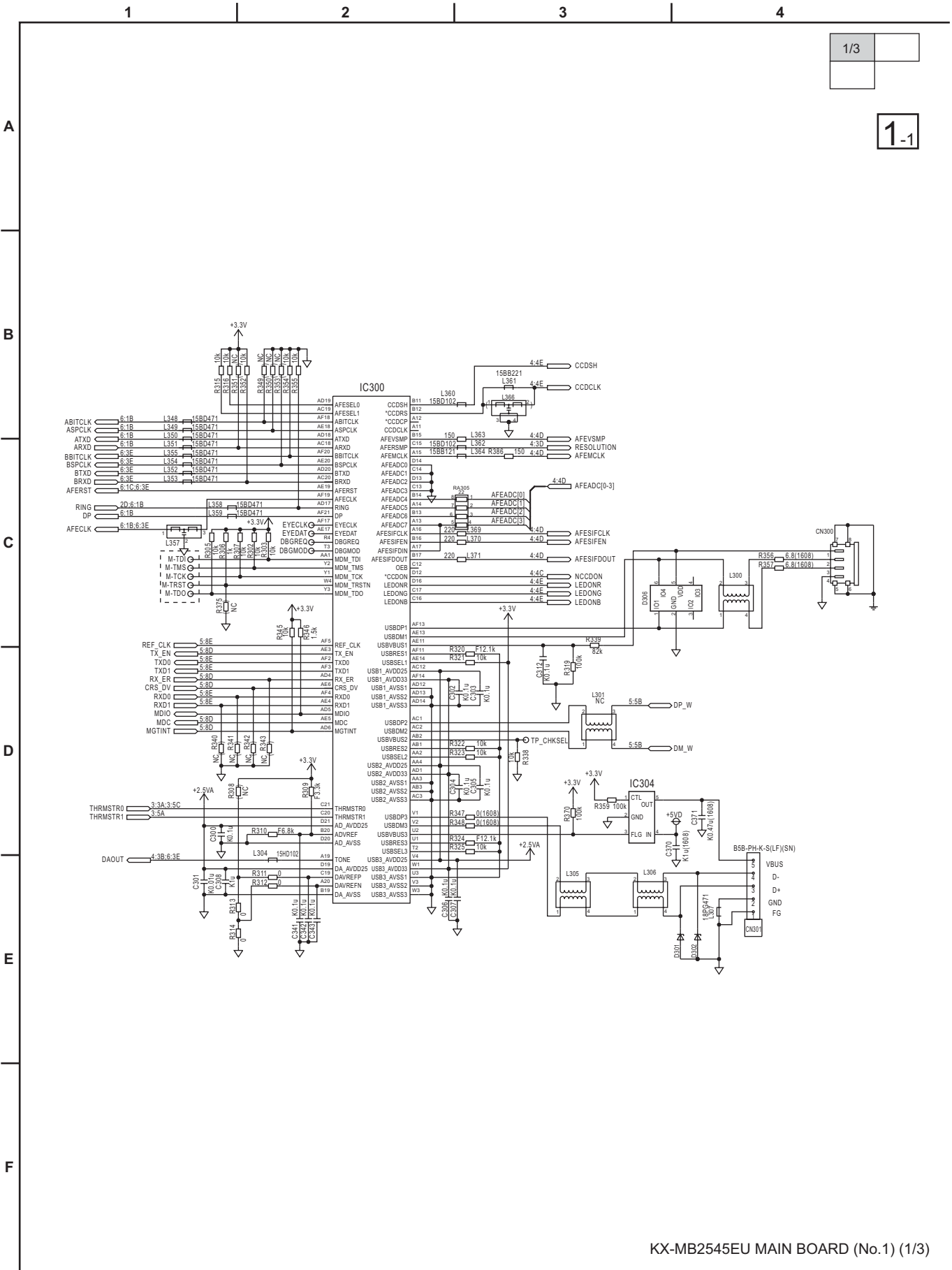

KX-MB2545EU MAIN BOARD (No.1) (1/3)

5

6

7

8

2/3

1-2

A

B

C

D

E

F

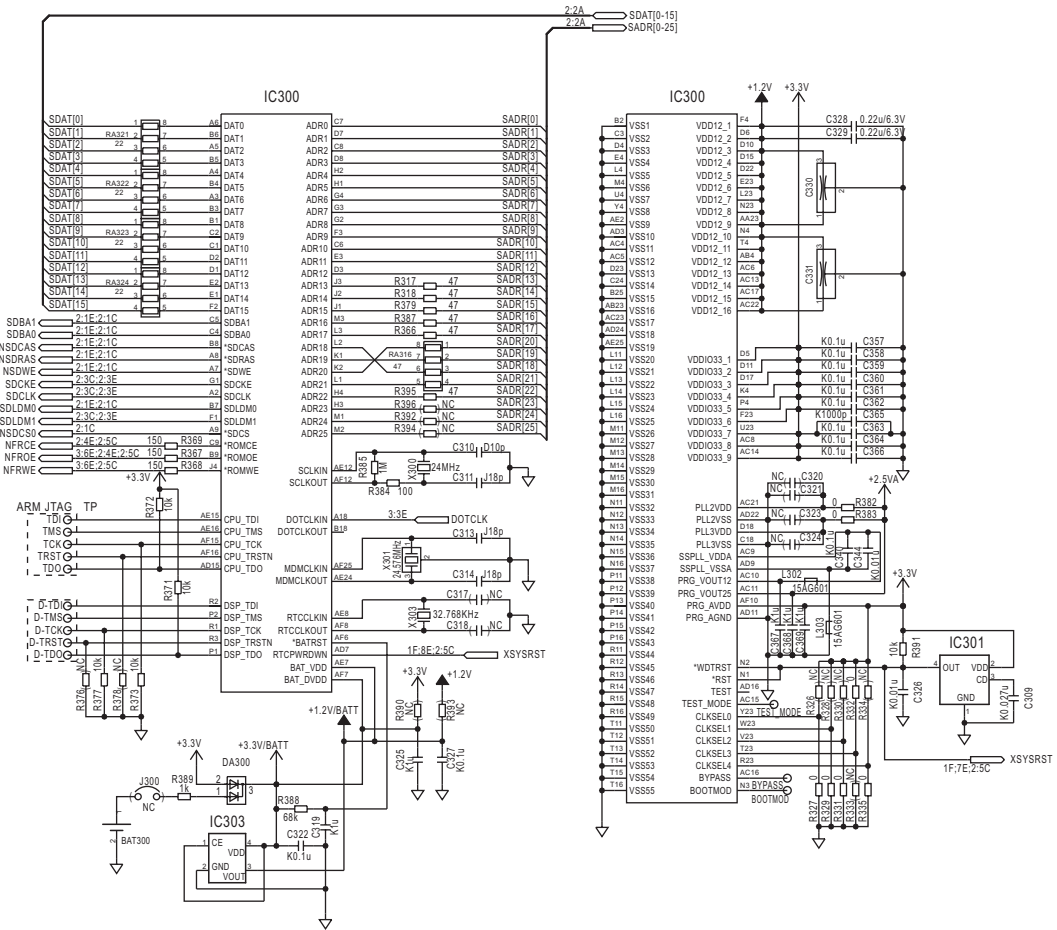

KX-MB2545EU MAIN BOARD (No.1) (2/3)

H
I
J
K
L
M

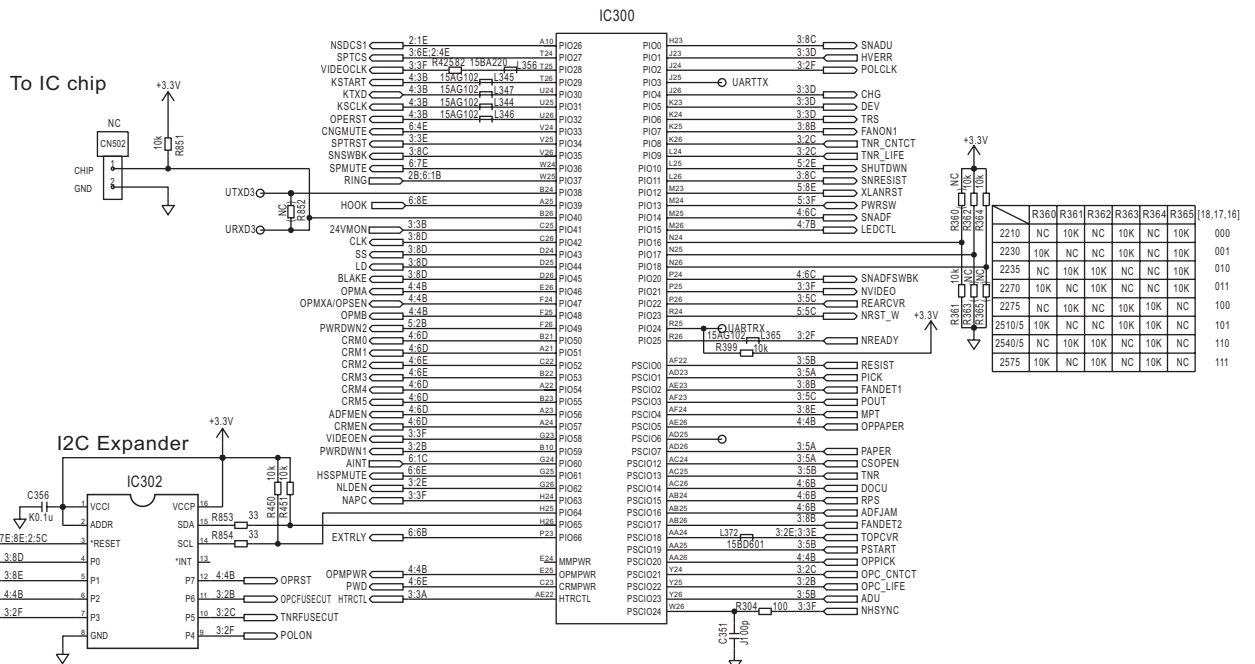

KX-MB2545EU MAIN BOARD (No.1) (3/3)

Memo

16.5.2. Main Board(2)

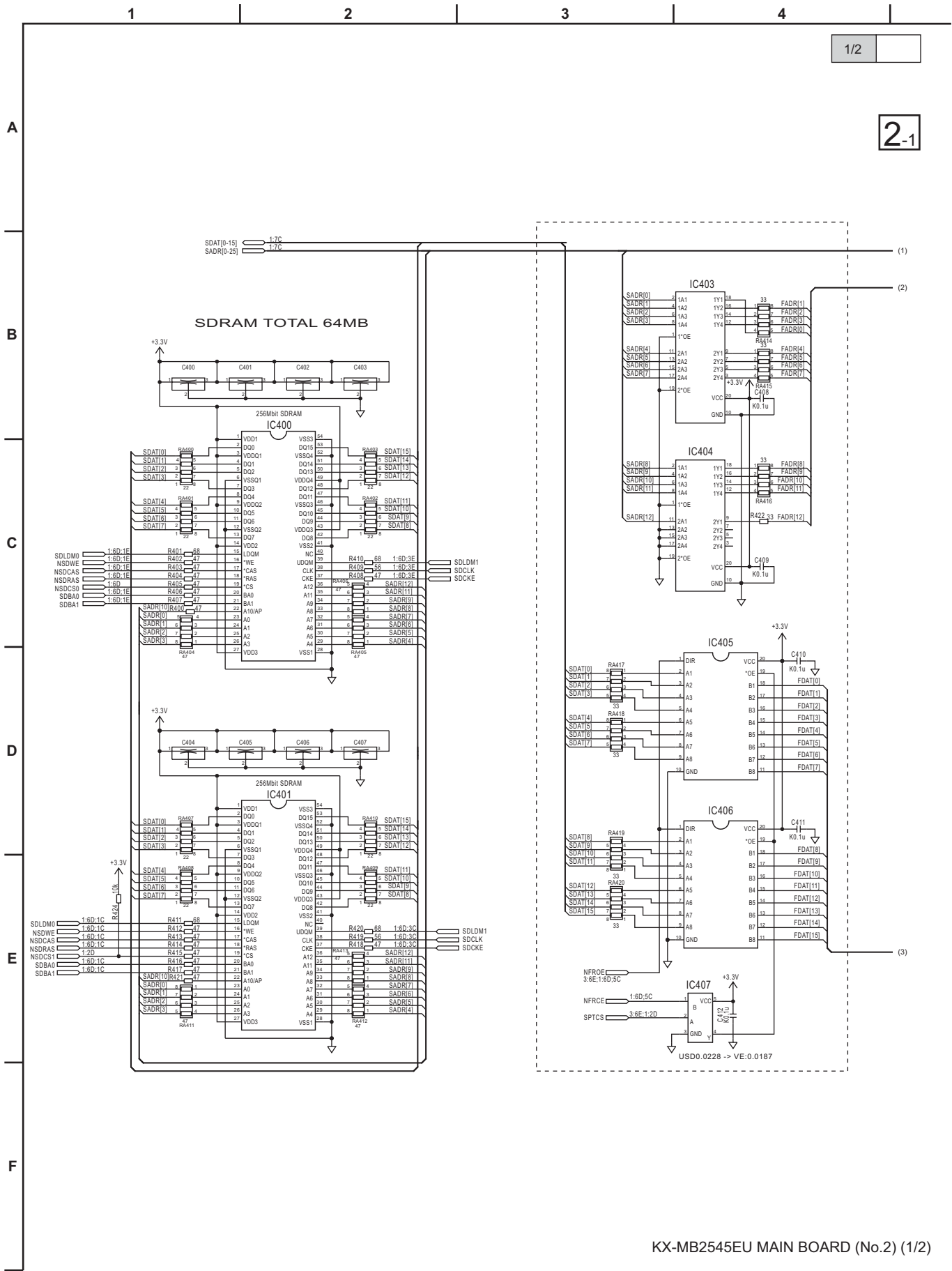

KX-MB2545EU MAIN BOARD (No.2) (1/2)

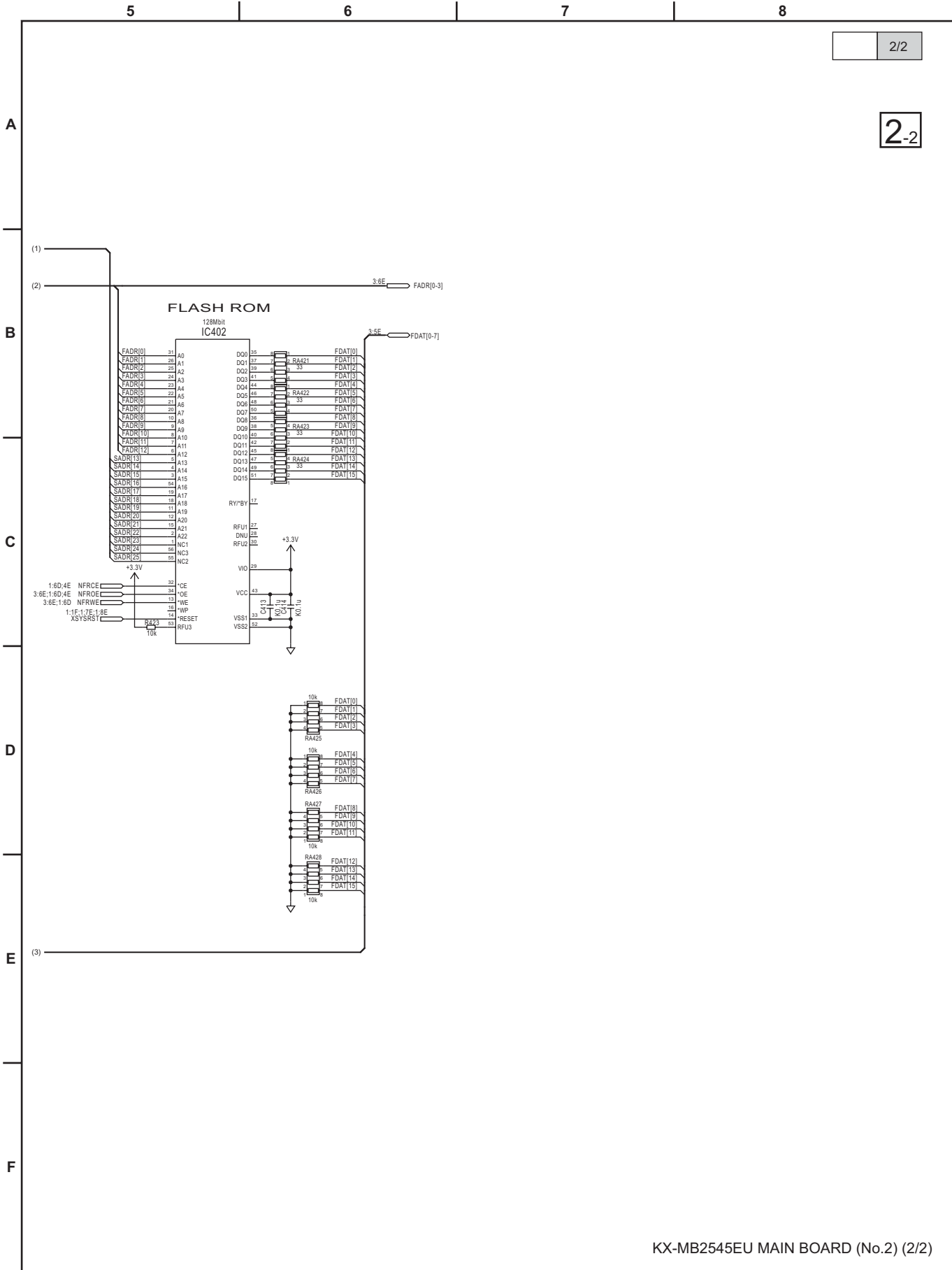

KX-MB2545EU MAIN BOARD (No.2) (2/2)

5

6

7

8

2/2

3-2

A

B

C

D

E

F

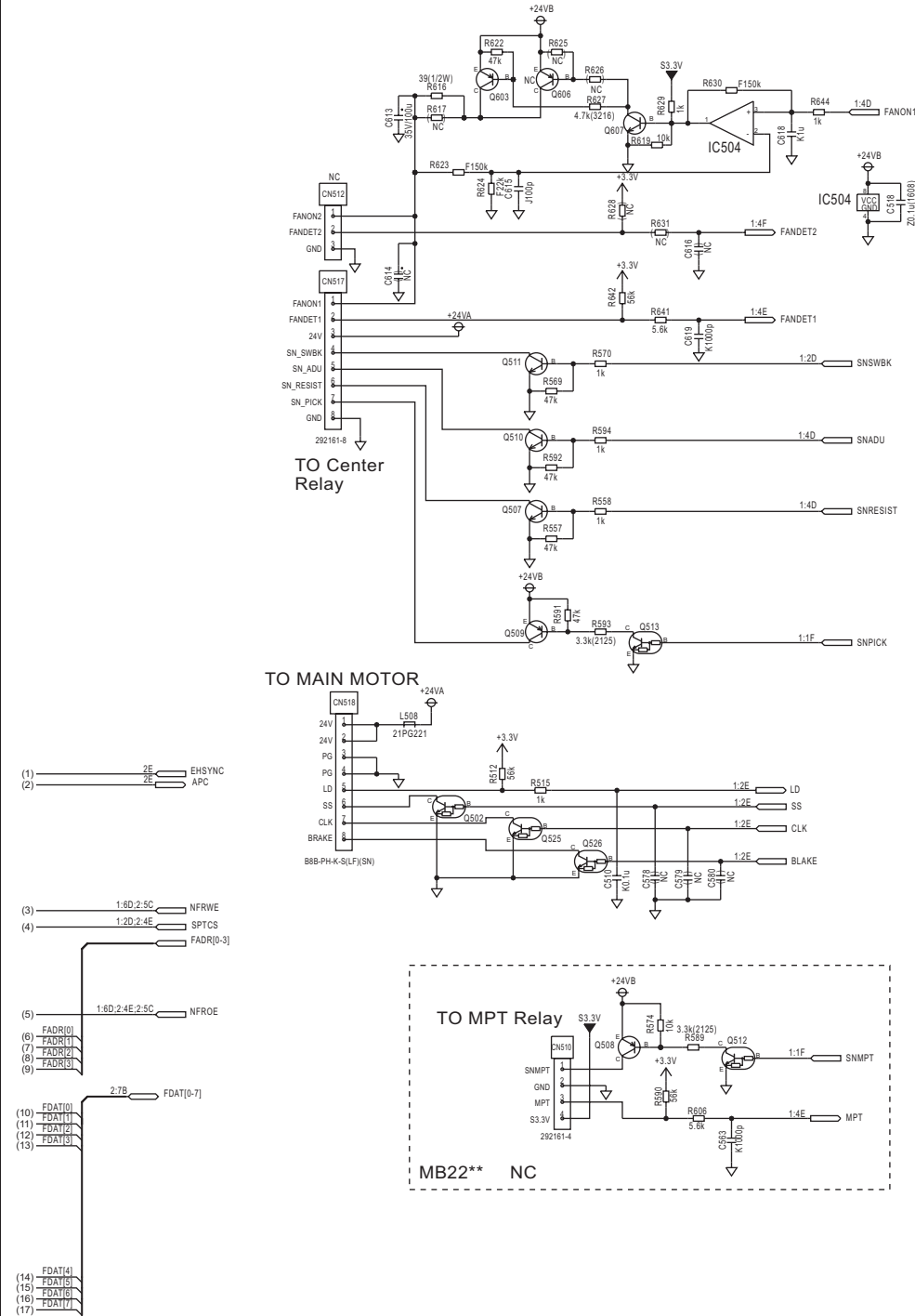

5

6

7

8

2/2

4-2

A
B
C
D
E
F

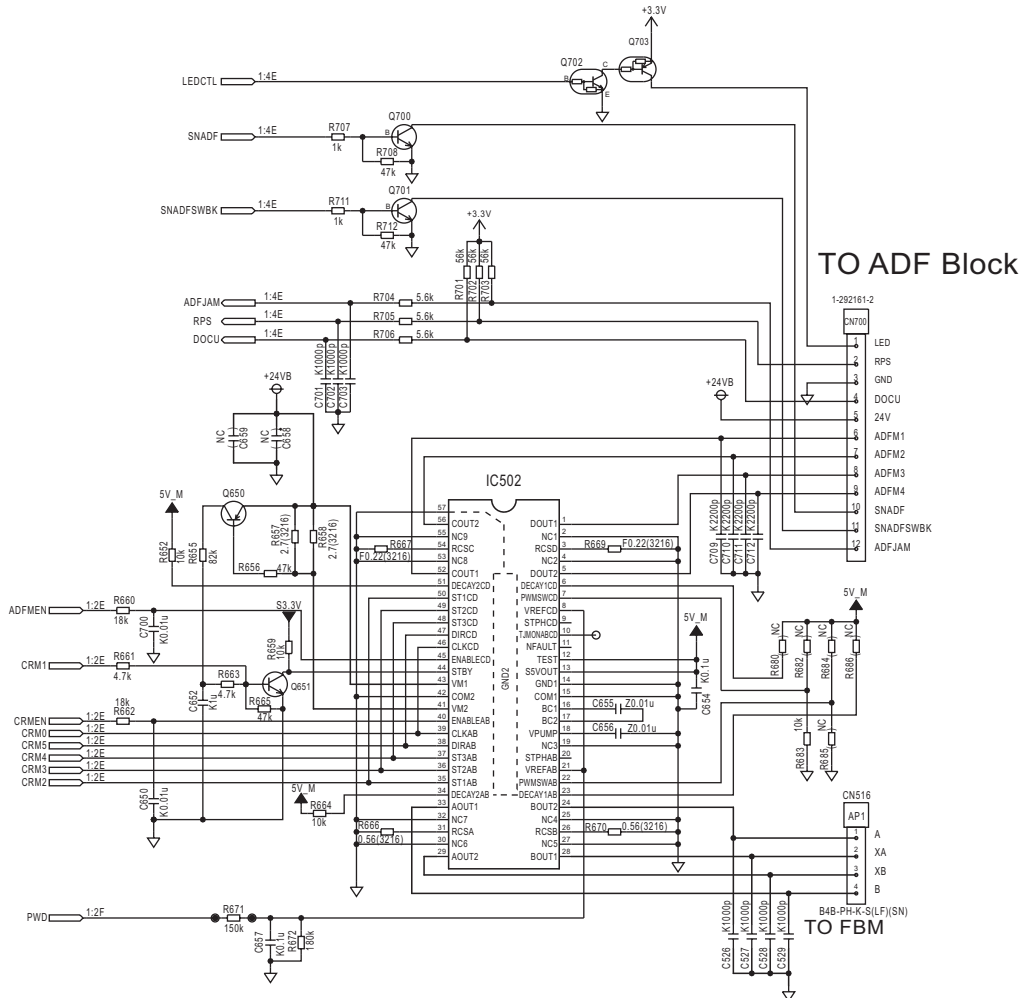

KX-MB2545EU MAIN BOARD (No.4) (1/2)

16.5.5. Main Board(5)

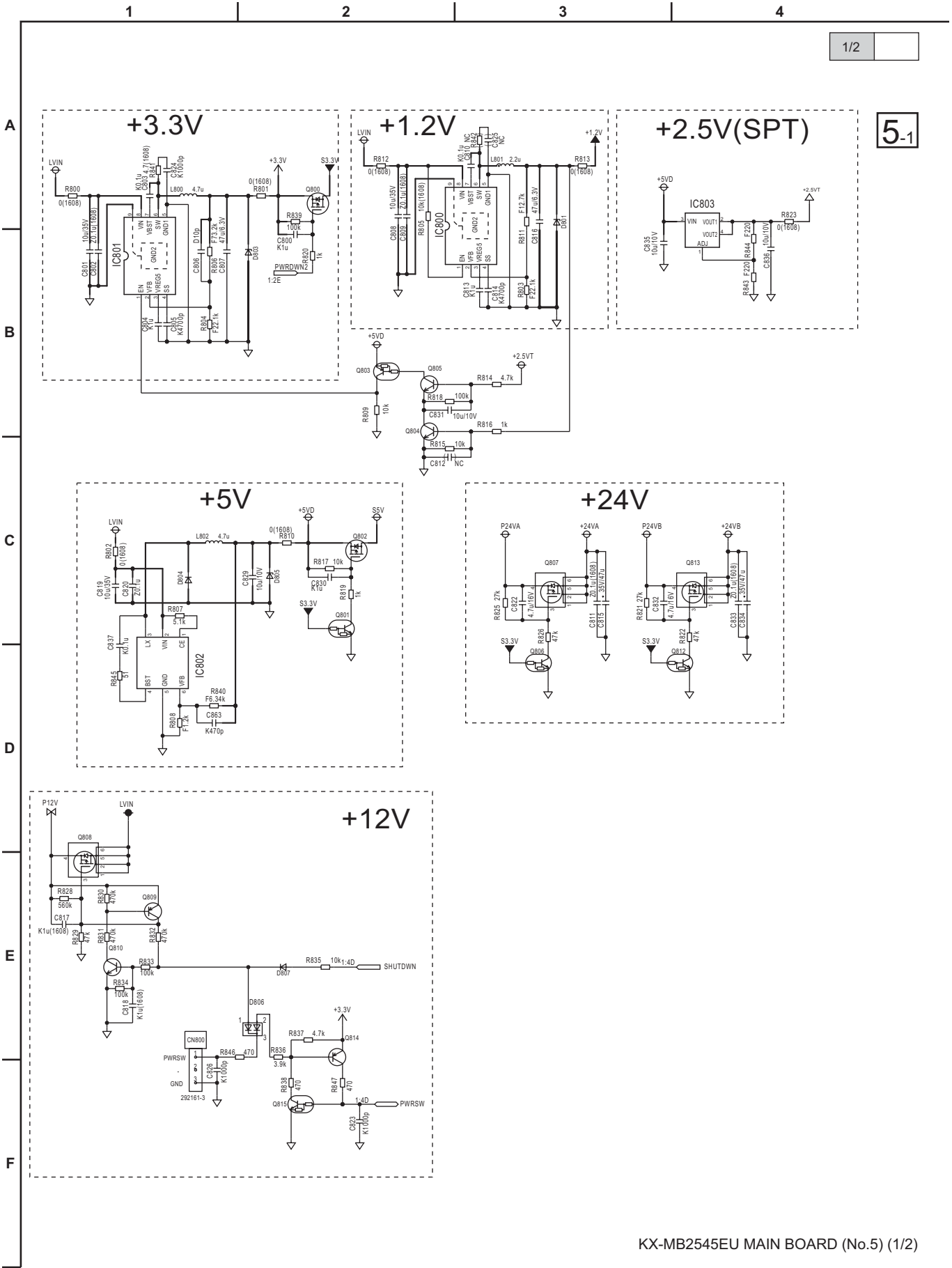

KX-MB2545EU MAIN BOARD (No.5) (1/2)

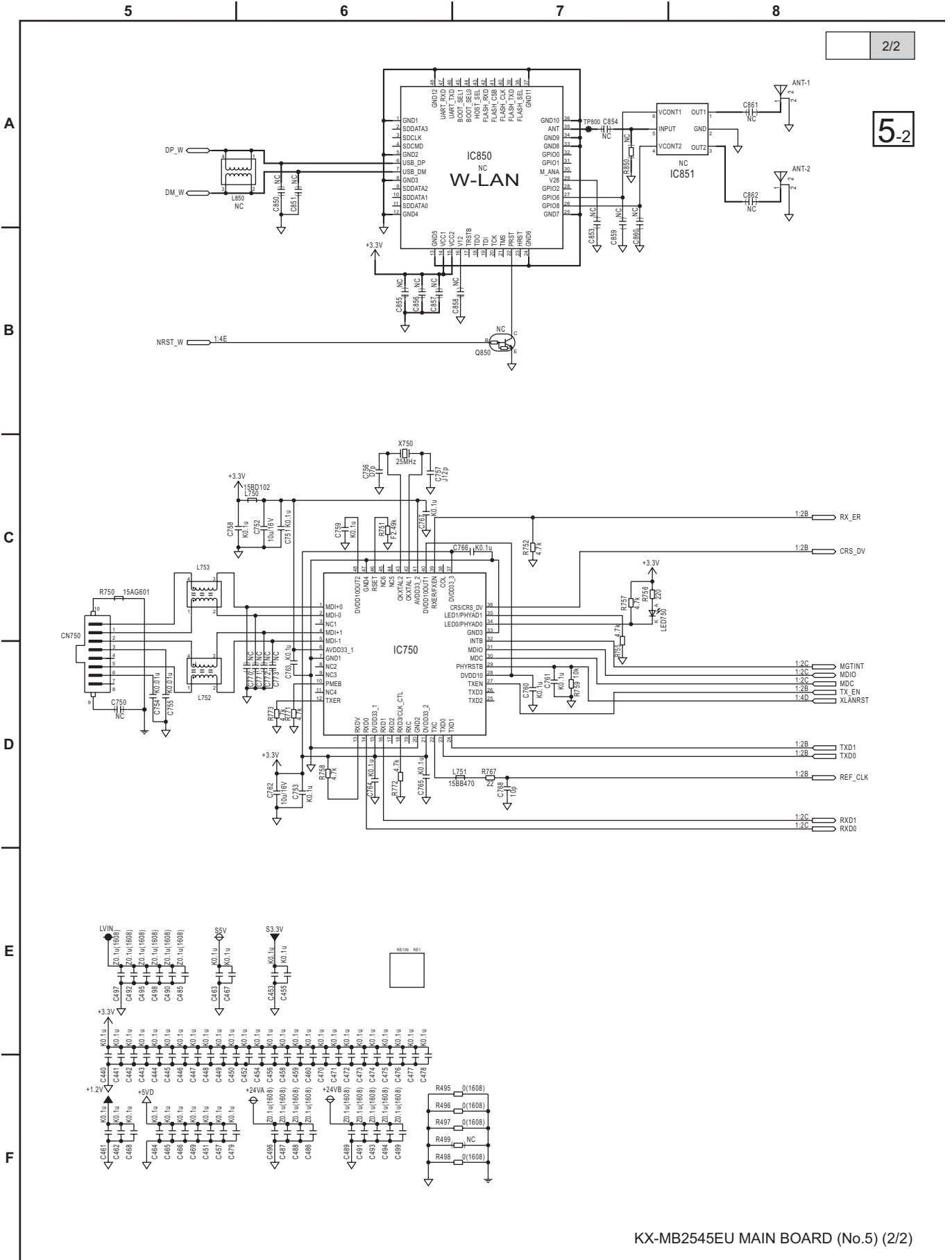

KX-MB2545EU MAIN BOARD (No.5) (2/2)

16.5.6. Main Board(6)

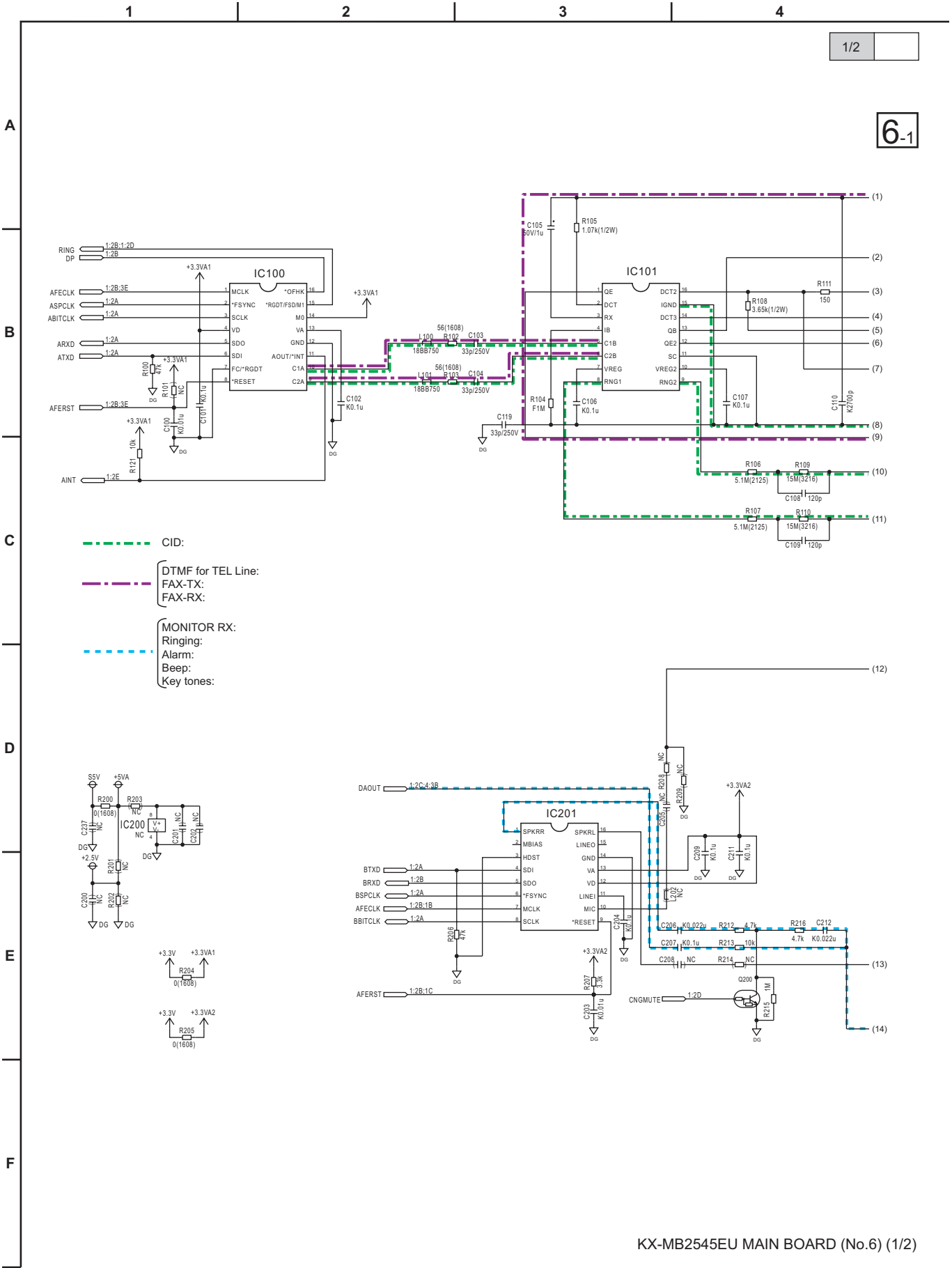

6-2

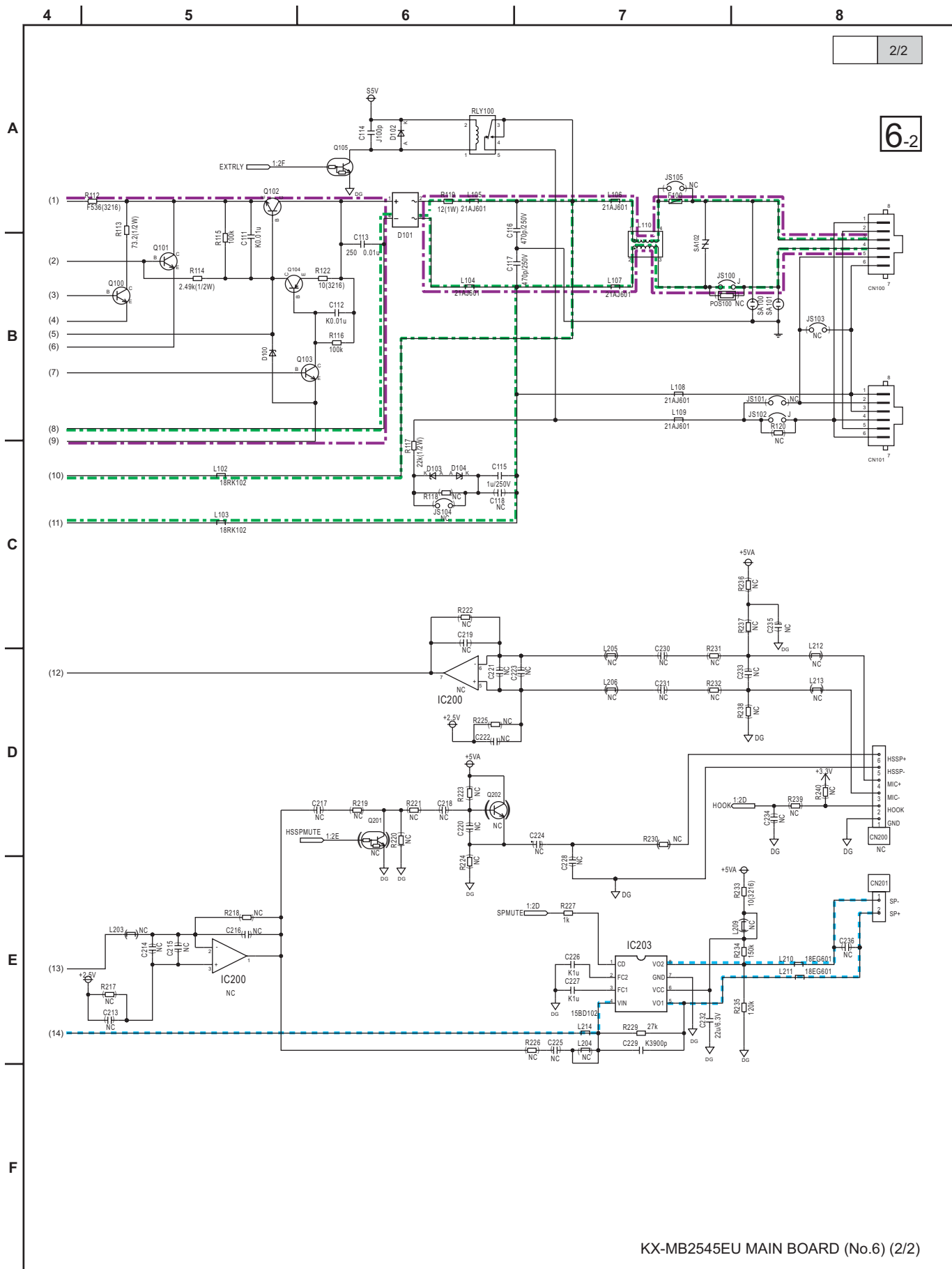

KX-MB2545EU MAIN BOARD (No.6) (2/2)

16.6. Main Board (KX-MB2575)

16.6.1. Main Board(1)

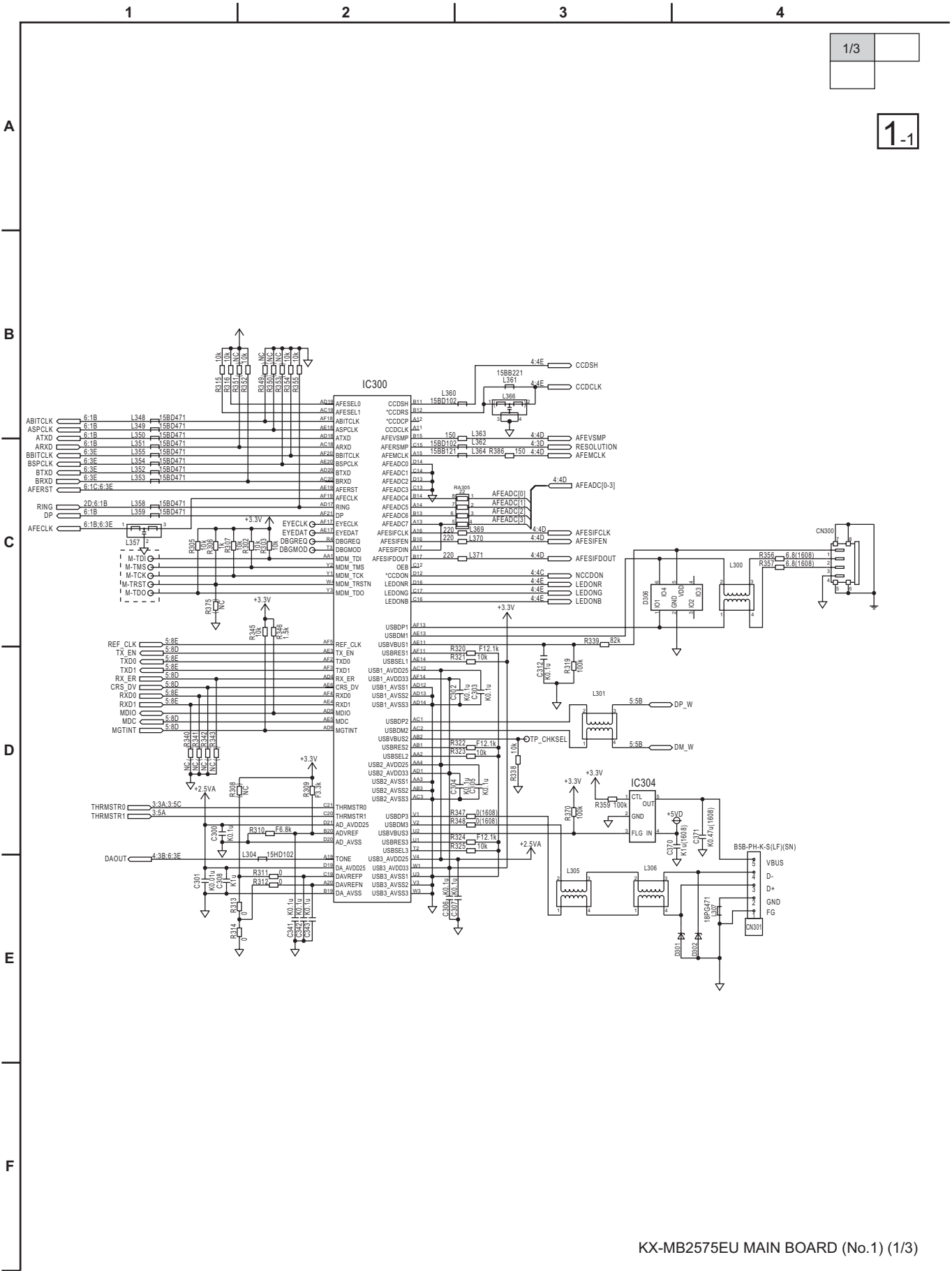

KX-MB2575EU MAIN BOARD (No.1) (1/3)

1

2

3

4

3/3

1-3

H

I

J

K

L

M

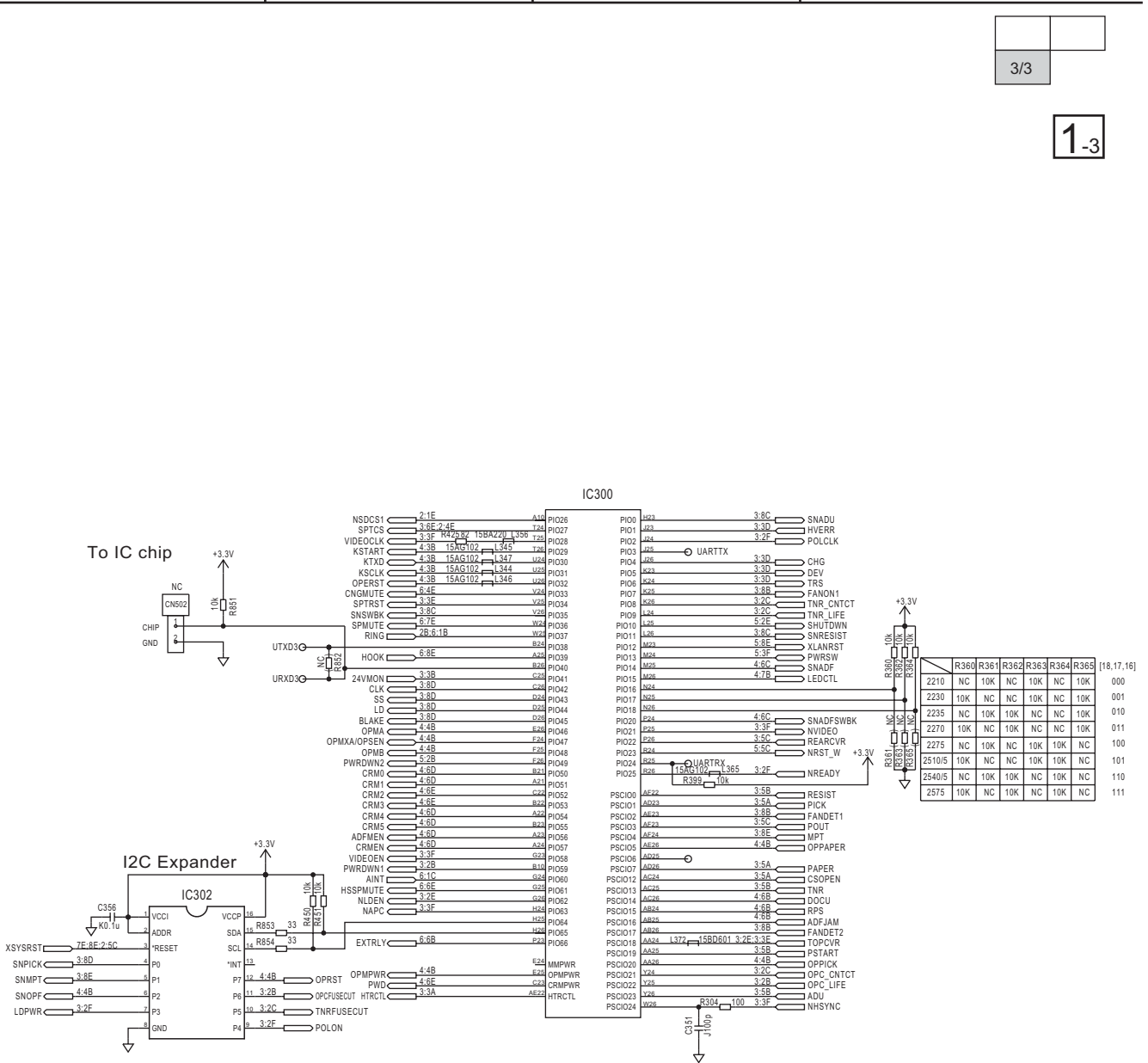

KX-MB2575EU MAIN BOARD (No.1) (3/3)

Memo

16.6.2. Main Board(2)

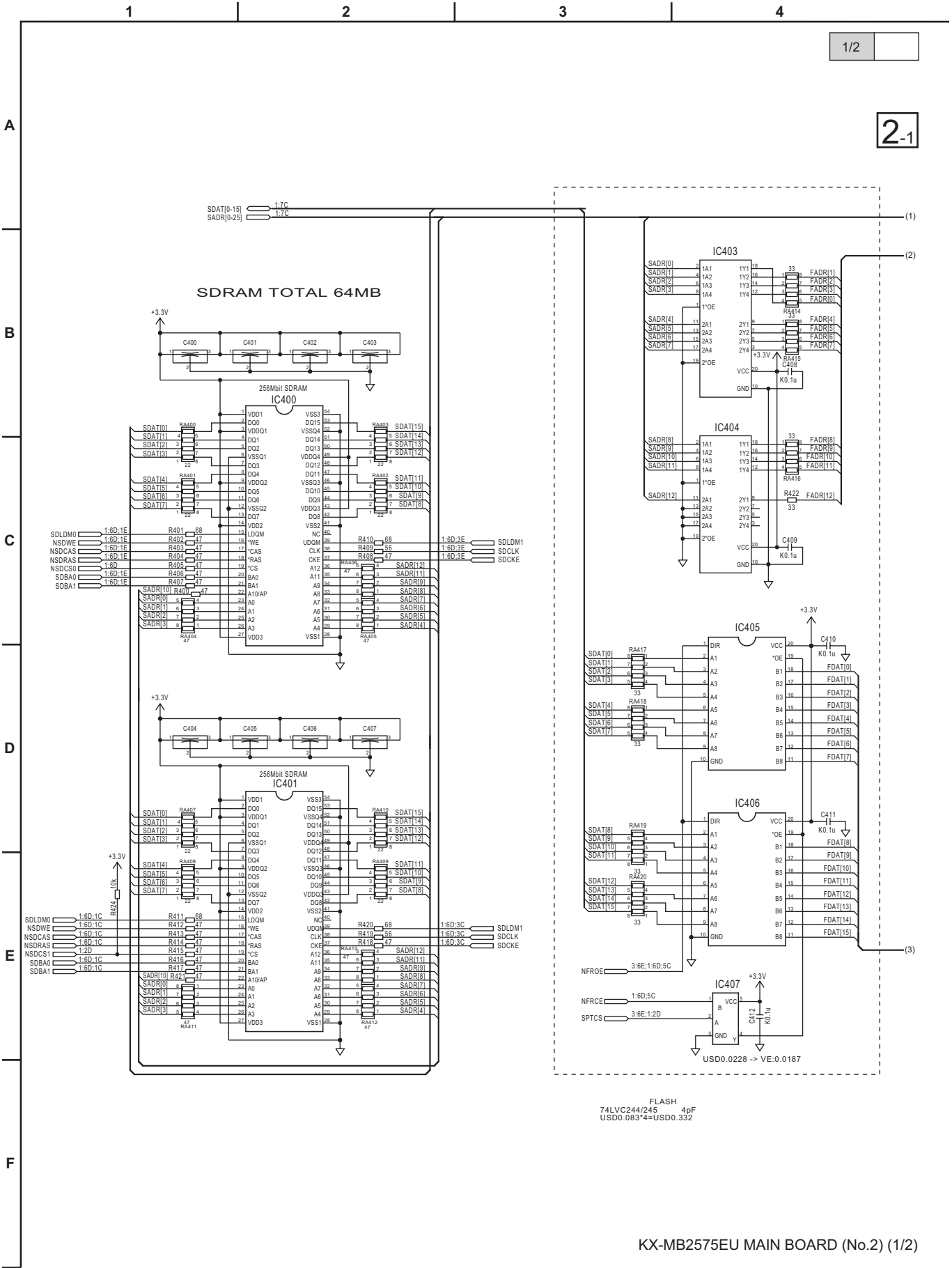

4 | 5 | 6 | 7 | 8

2/2

2-2

A

B

C

D

E

F

(1)

(2)

(3)

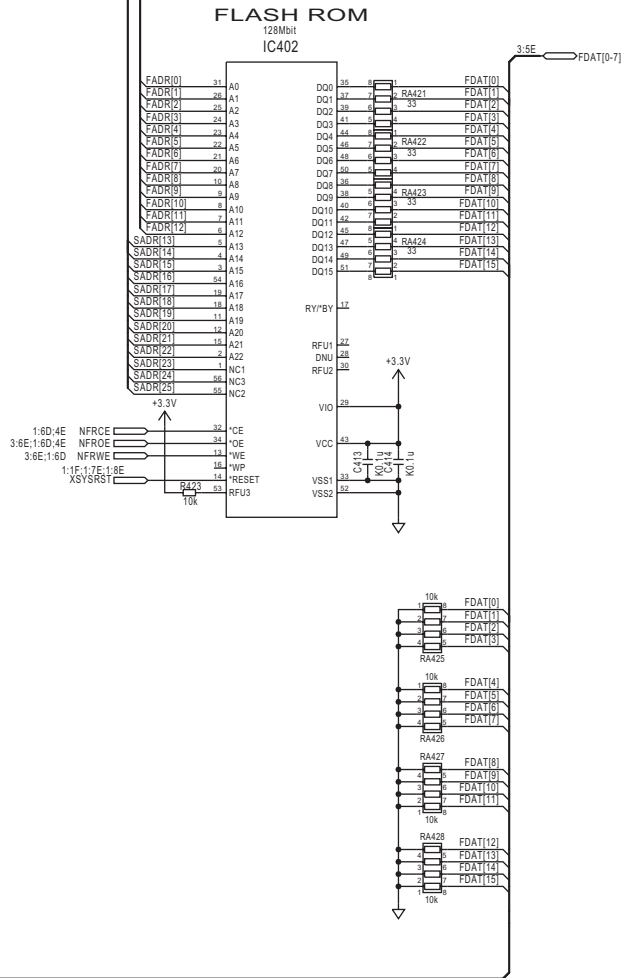

16.6.3. Main Board(3)

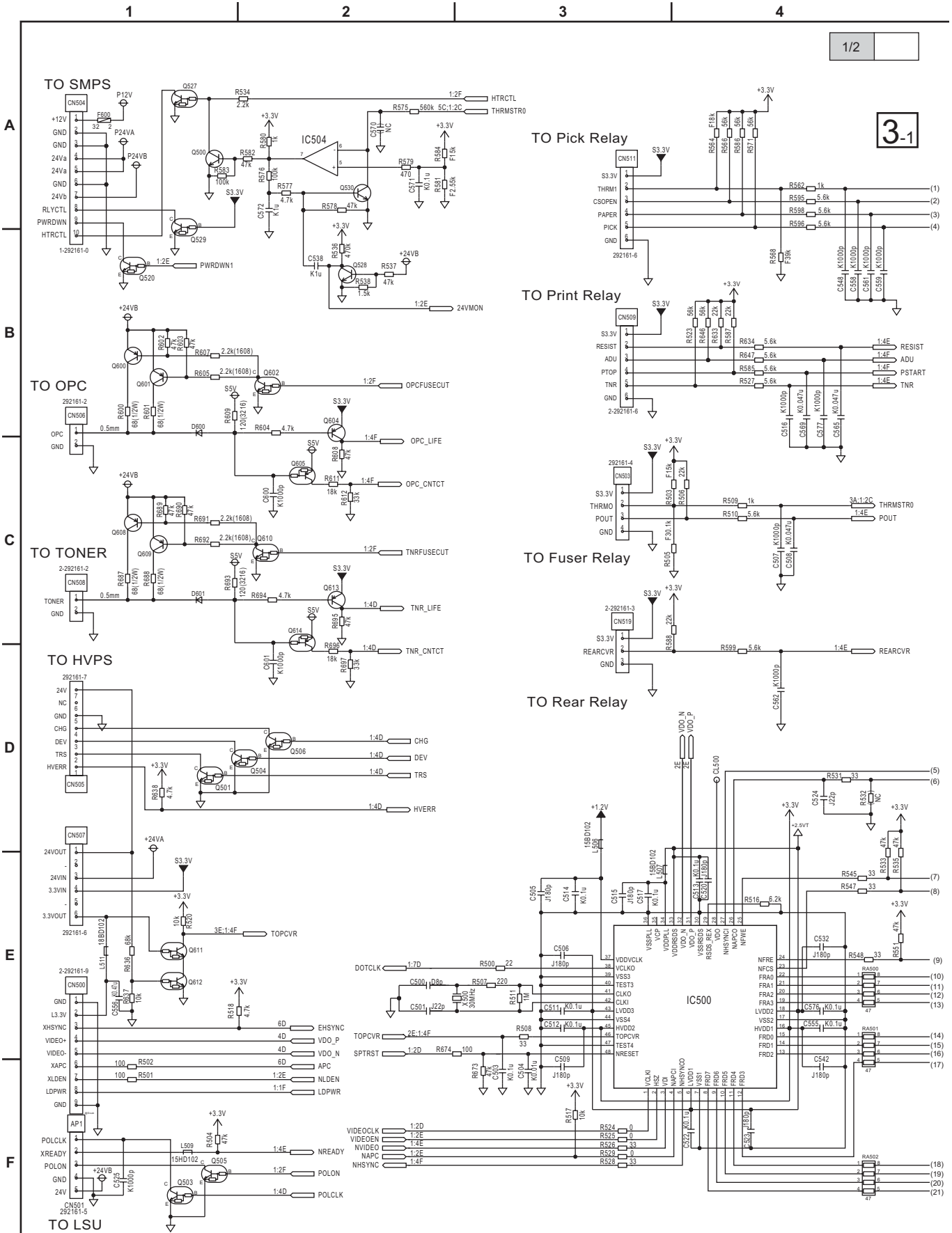

KX-MB2575EU MAIN BOARD (No.3) (1/2)

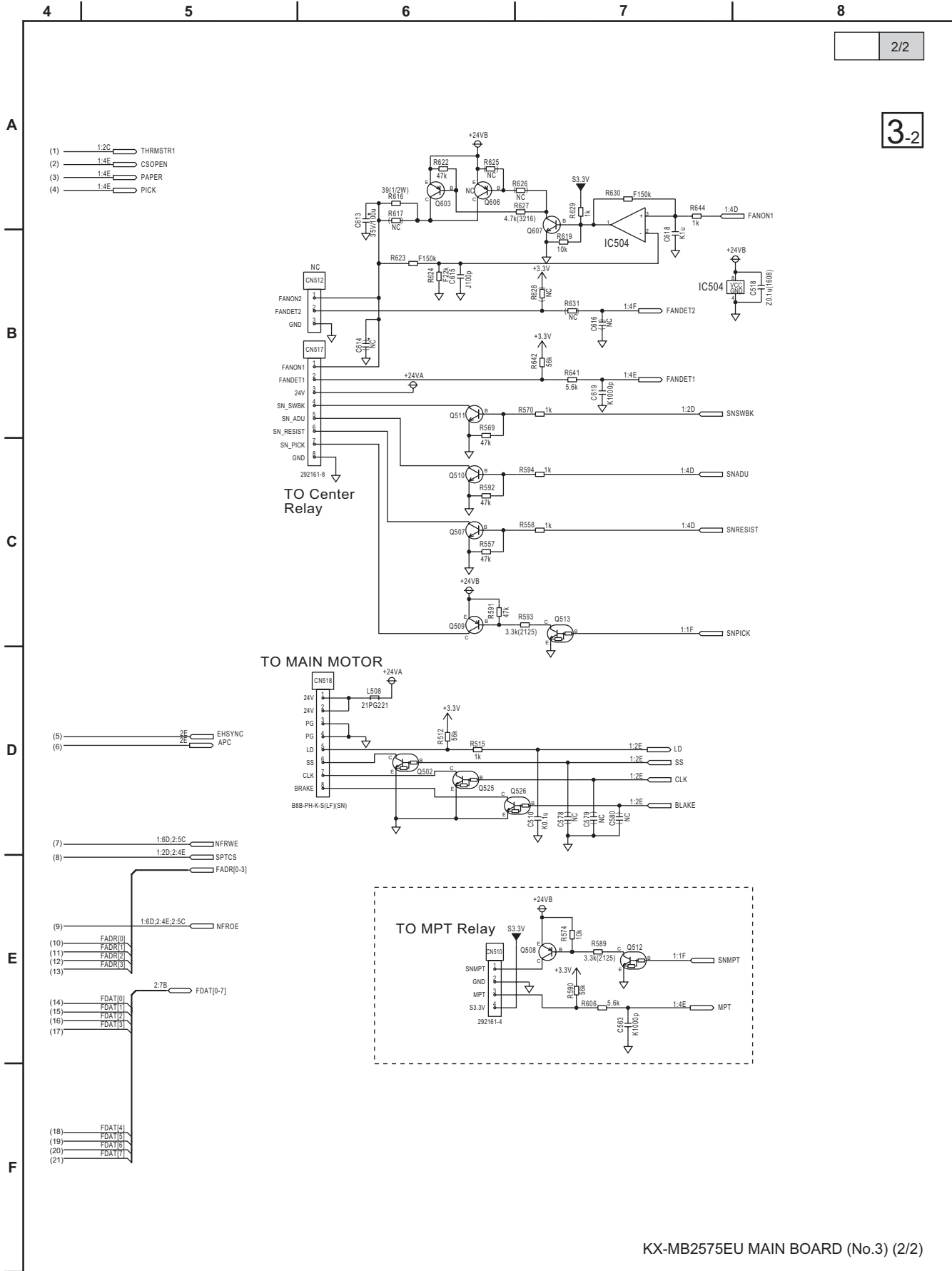

KX-MB2575EU MAIN BOARD (No.3) (2/2)

16.6.4. Main Board(4)

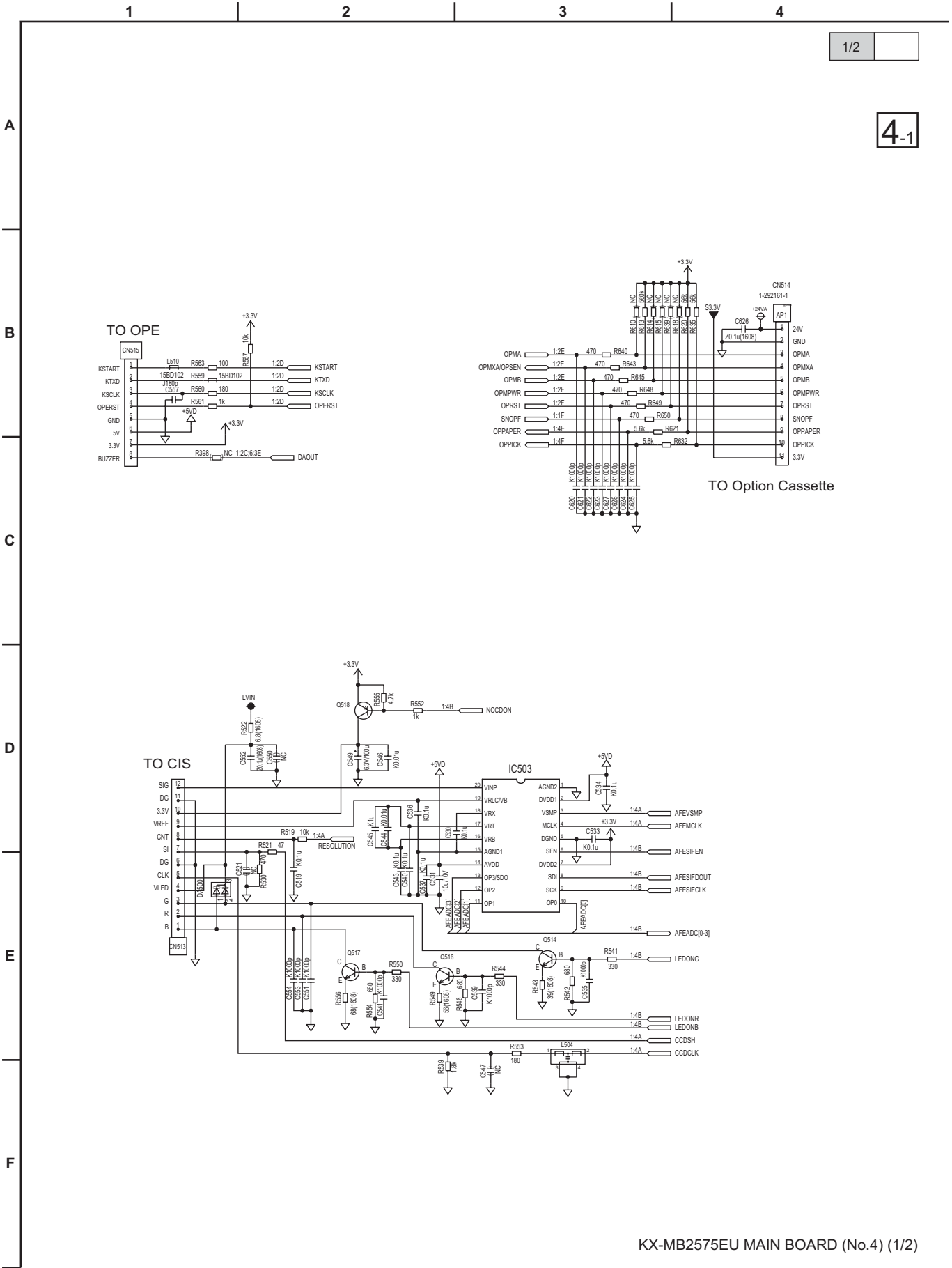

KX-MB2575EU MAIN BOARD (No.4) (1/2)

5

6

7

8

2/2

4-2

A

B

C

D

E

F

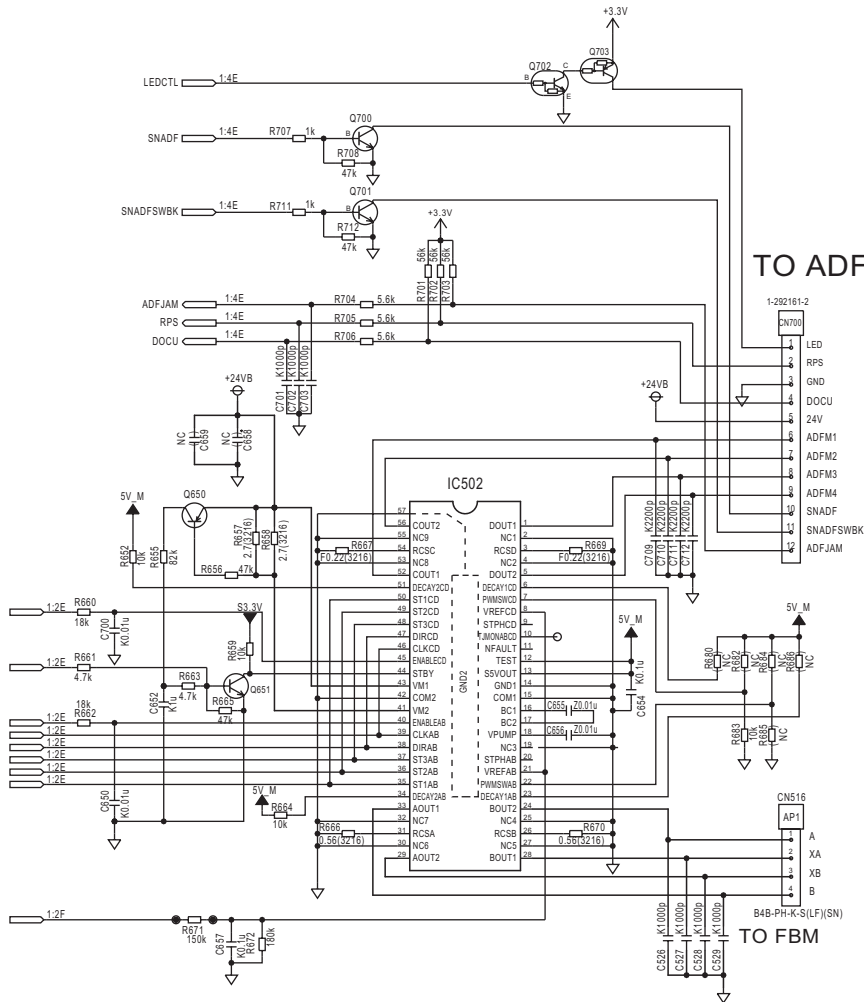

TO ADF Block

TO FBM

KX-MB2575EU MAIN BOARD (No.4) (2/2)

16.6.5. Main Board(5)

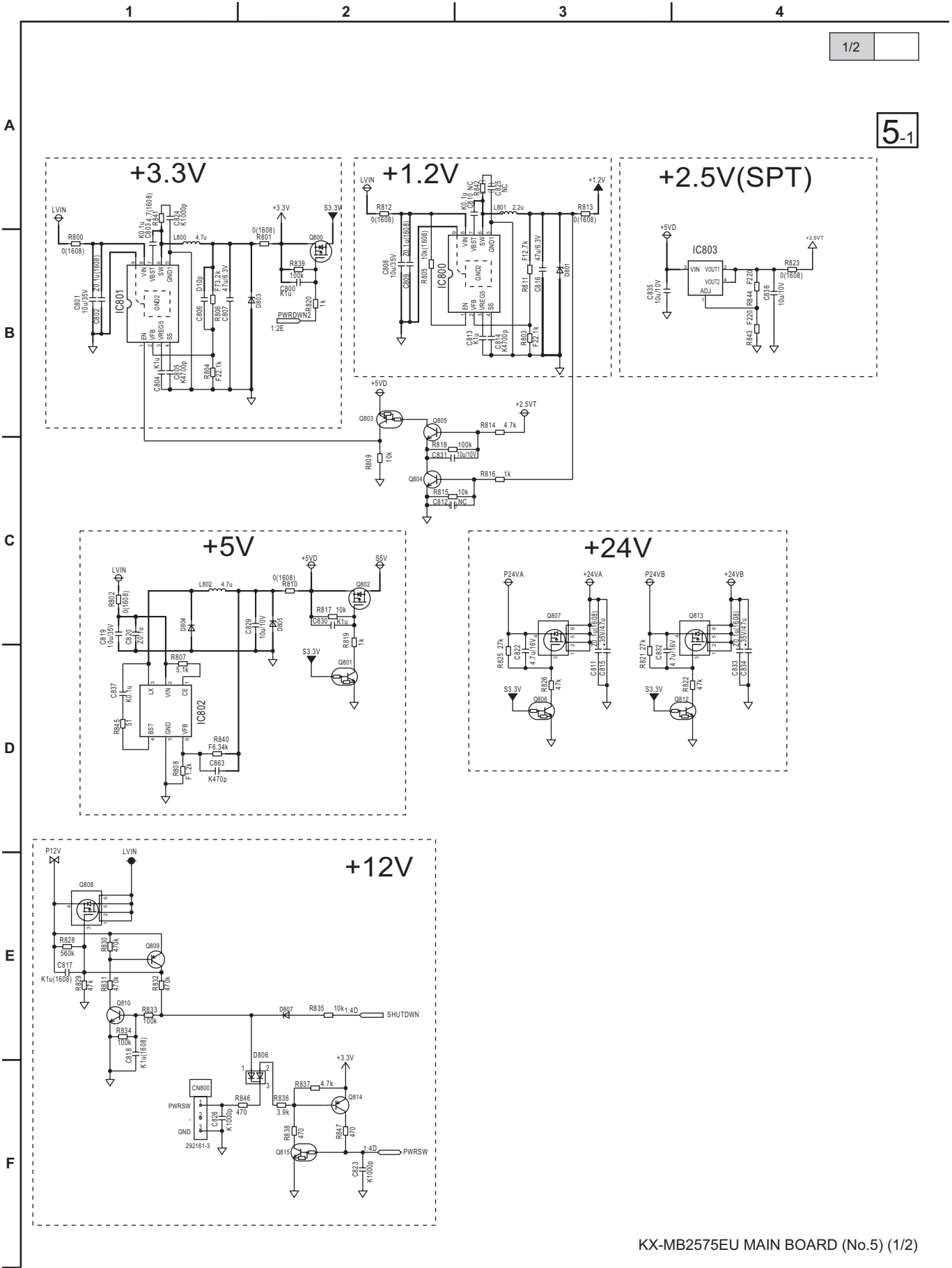

KX-MB2575EU MAIN BOARD (No.5) (1/2)

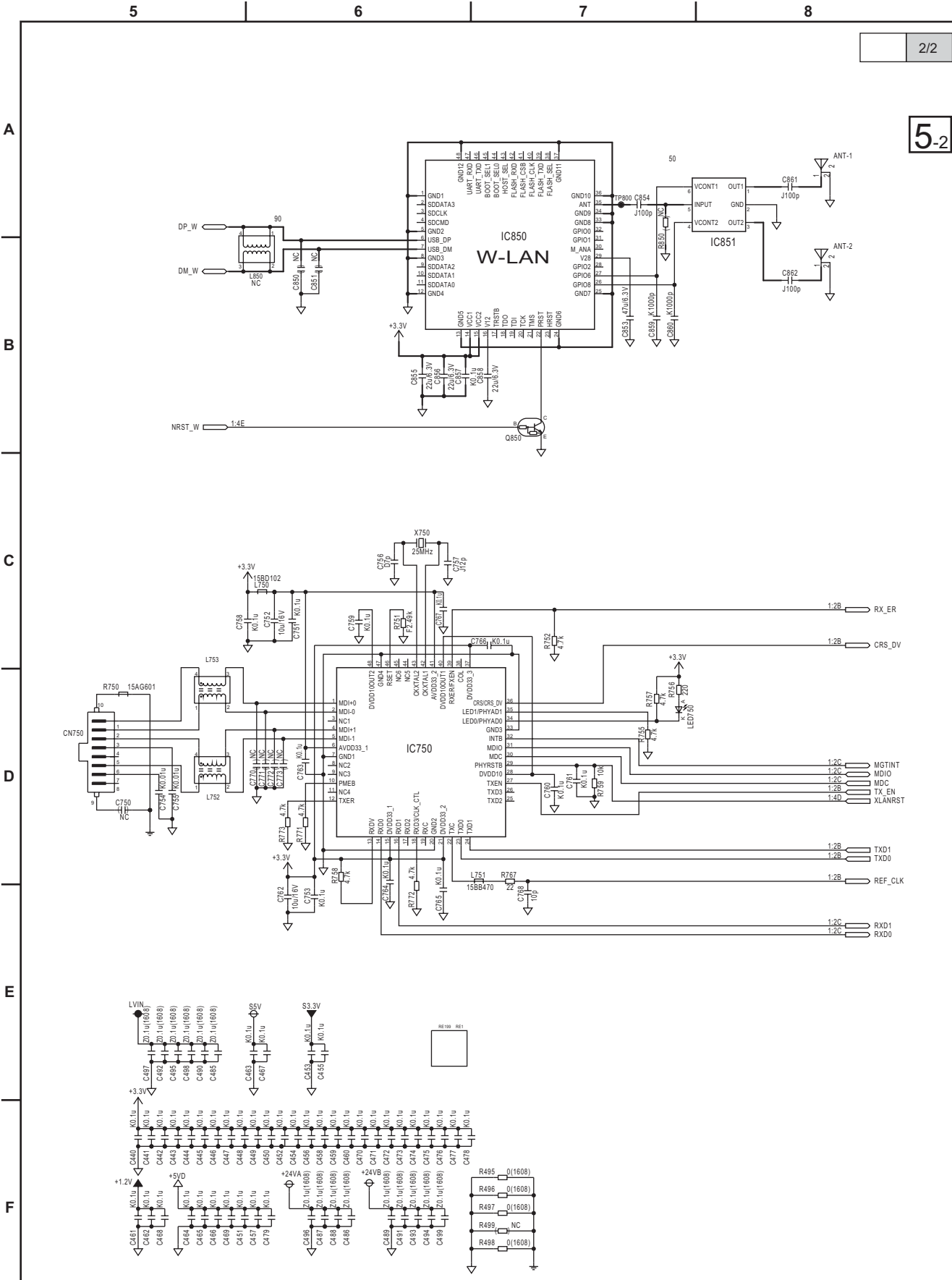

KX-MB2575EU MAIN BOARD (No.5) (2/2)

16.6.6. Main Board(6)

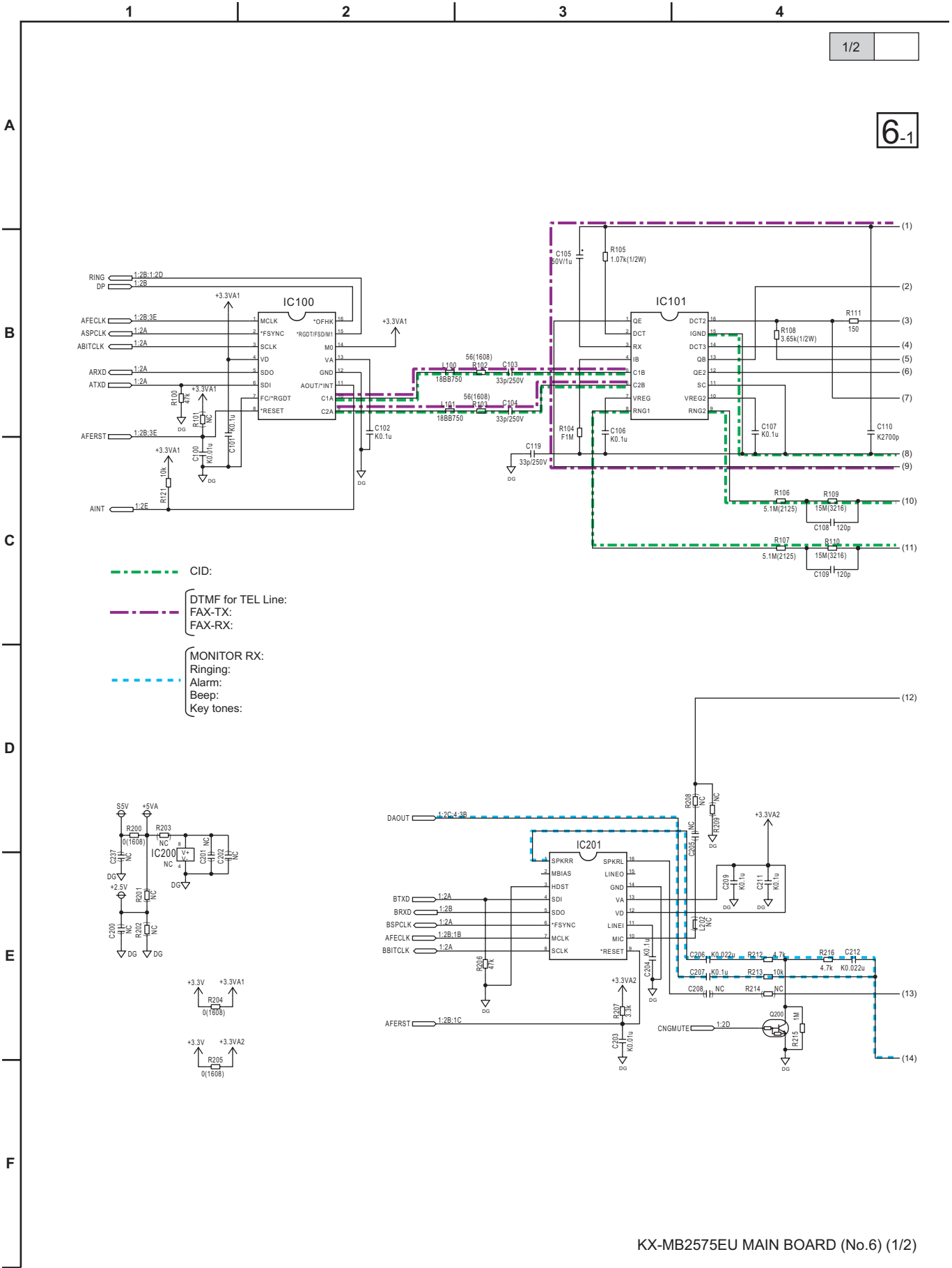

KX-MB2575EU MAIN BOARD (No.6) (1/2)

6-2

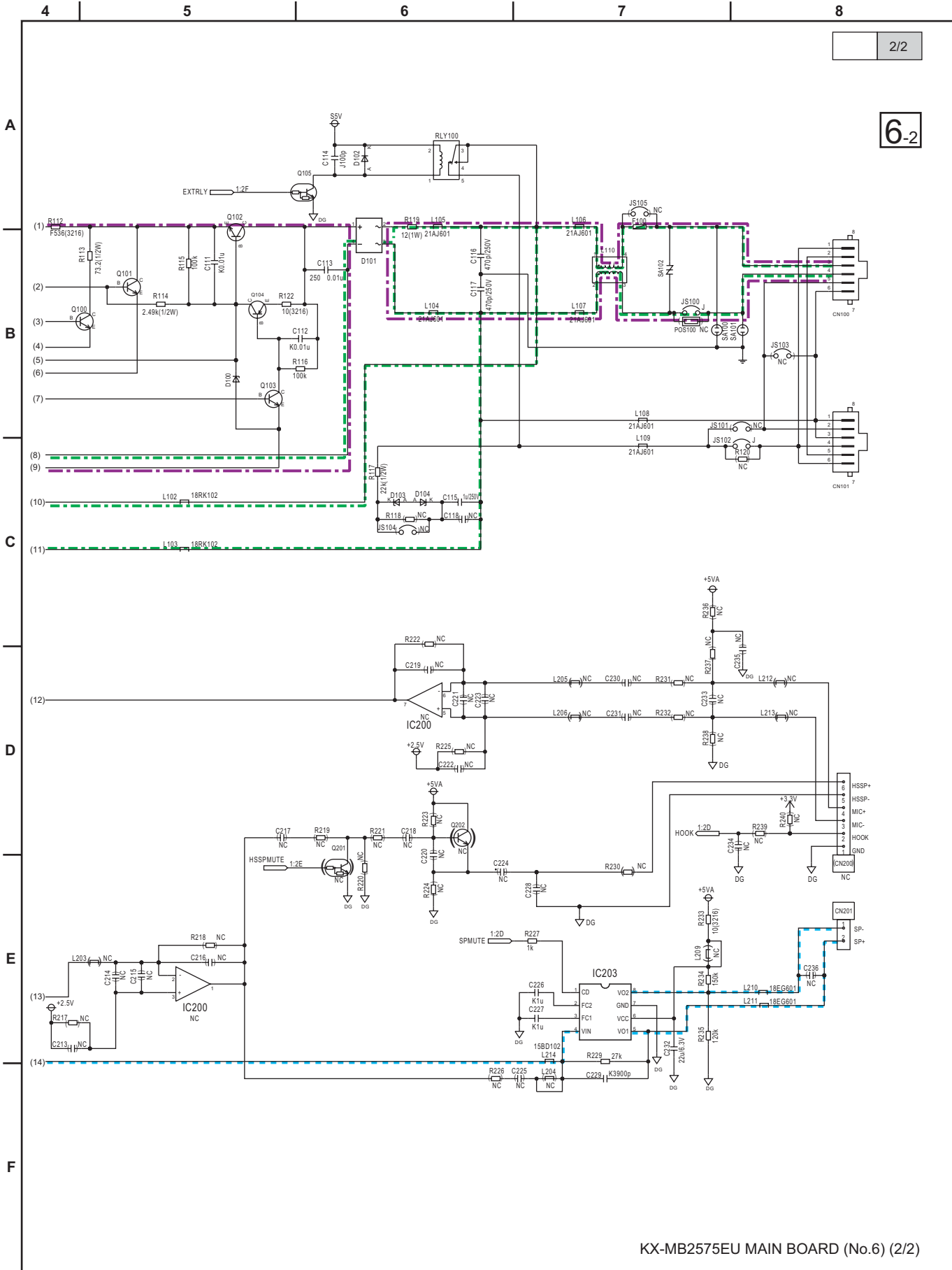

KX-MB2575EU MAIN BOARD (No.6) (2/2)

16.7. Main Board (DP-MB310)

16.7.1. Main Board(1)

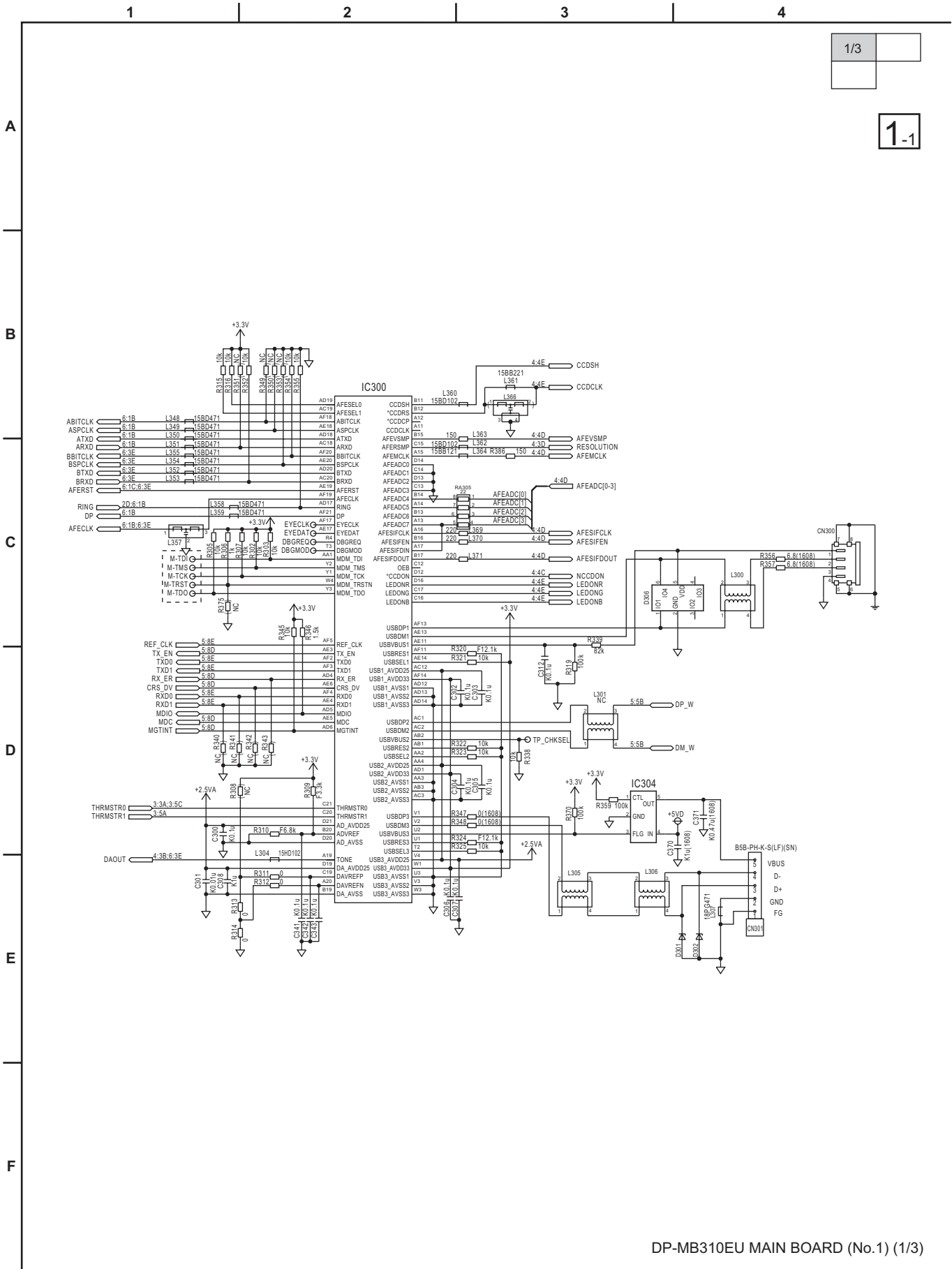

DP-MB310EU MAIN BOARD (No.1) (1/3)

5

6

7

8

2/3

1-2

A

B

C

D

E

F

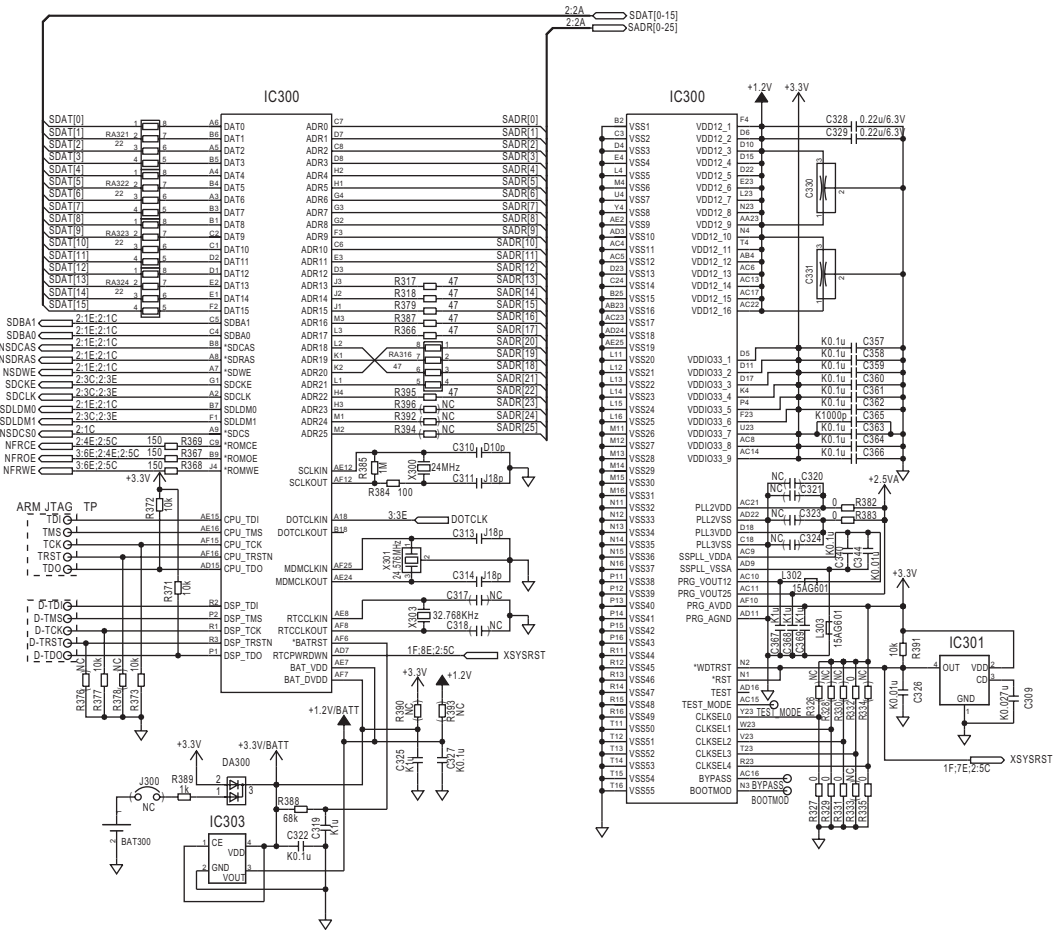

DP-MB310EU MAIN BOARD (No.1) (2/3)

H

I

J

K

L

M

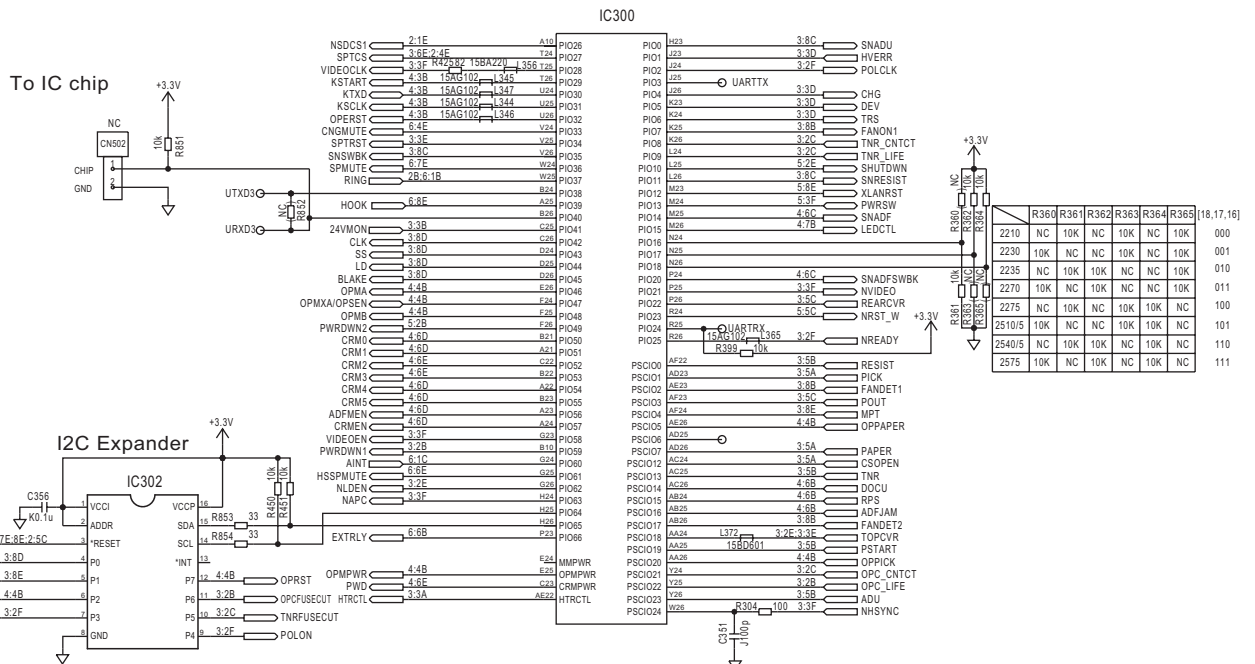

DP-MB310EU MAIN BOARD (No.1) (3/3)

Memo

16.7.2. Main Board(2)

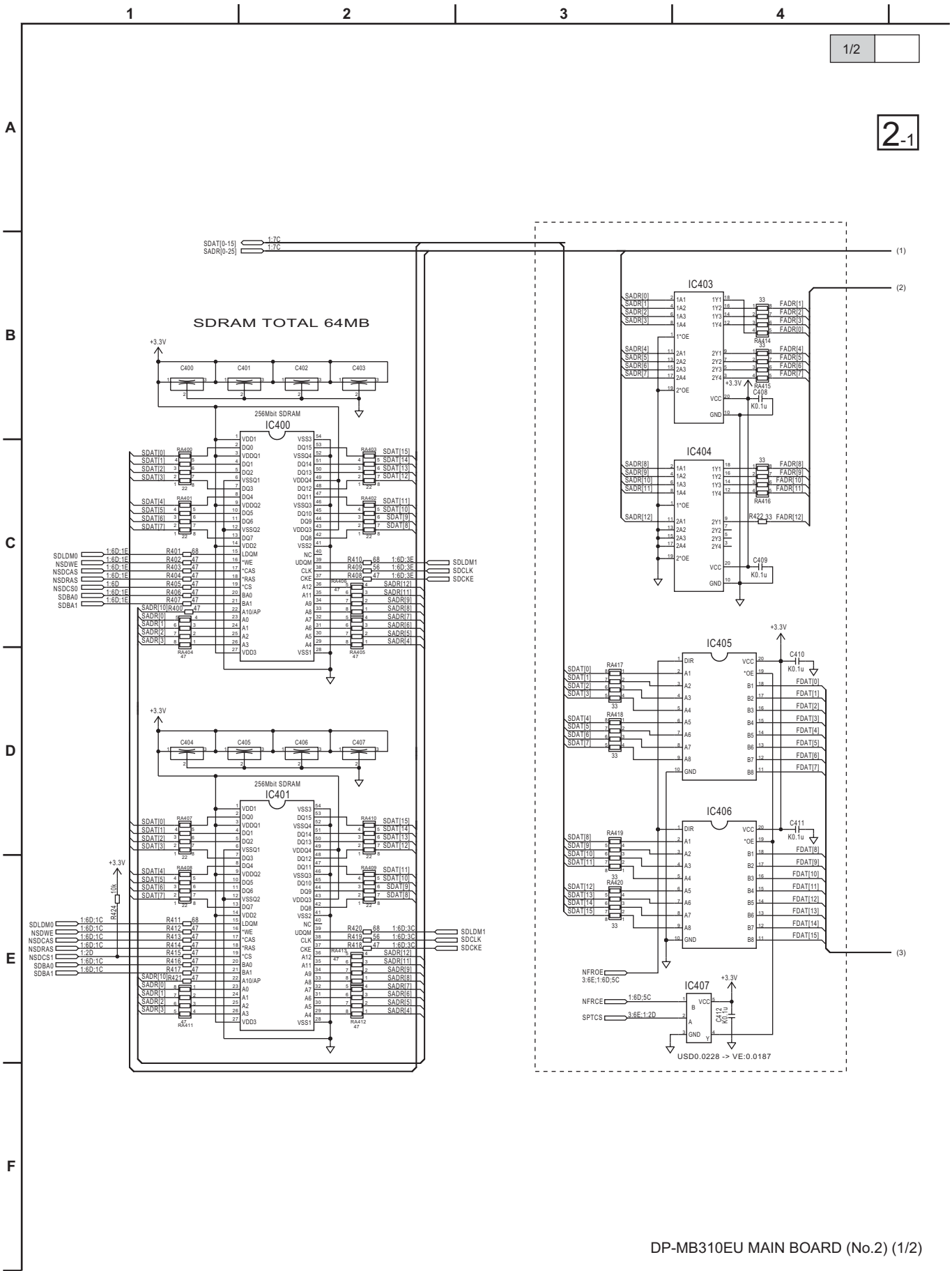

DP-MB310EU MAIN BOARD (No.2) (1/2)

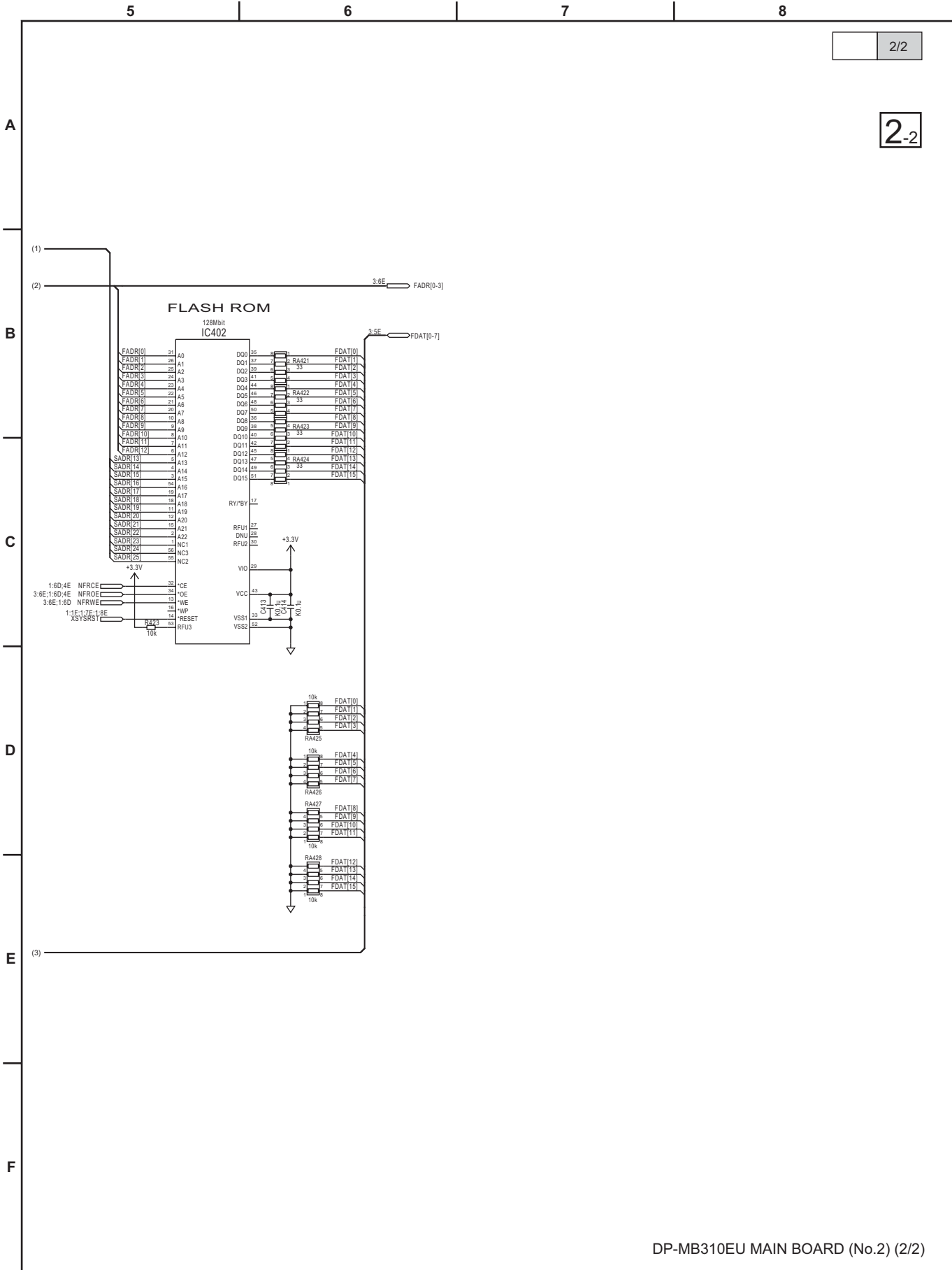

DP-MB310EU MAIN BOARD (No.2) (2/2)

16.7.3. Main Board(3)

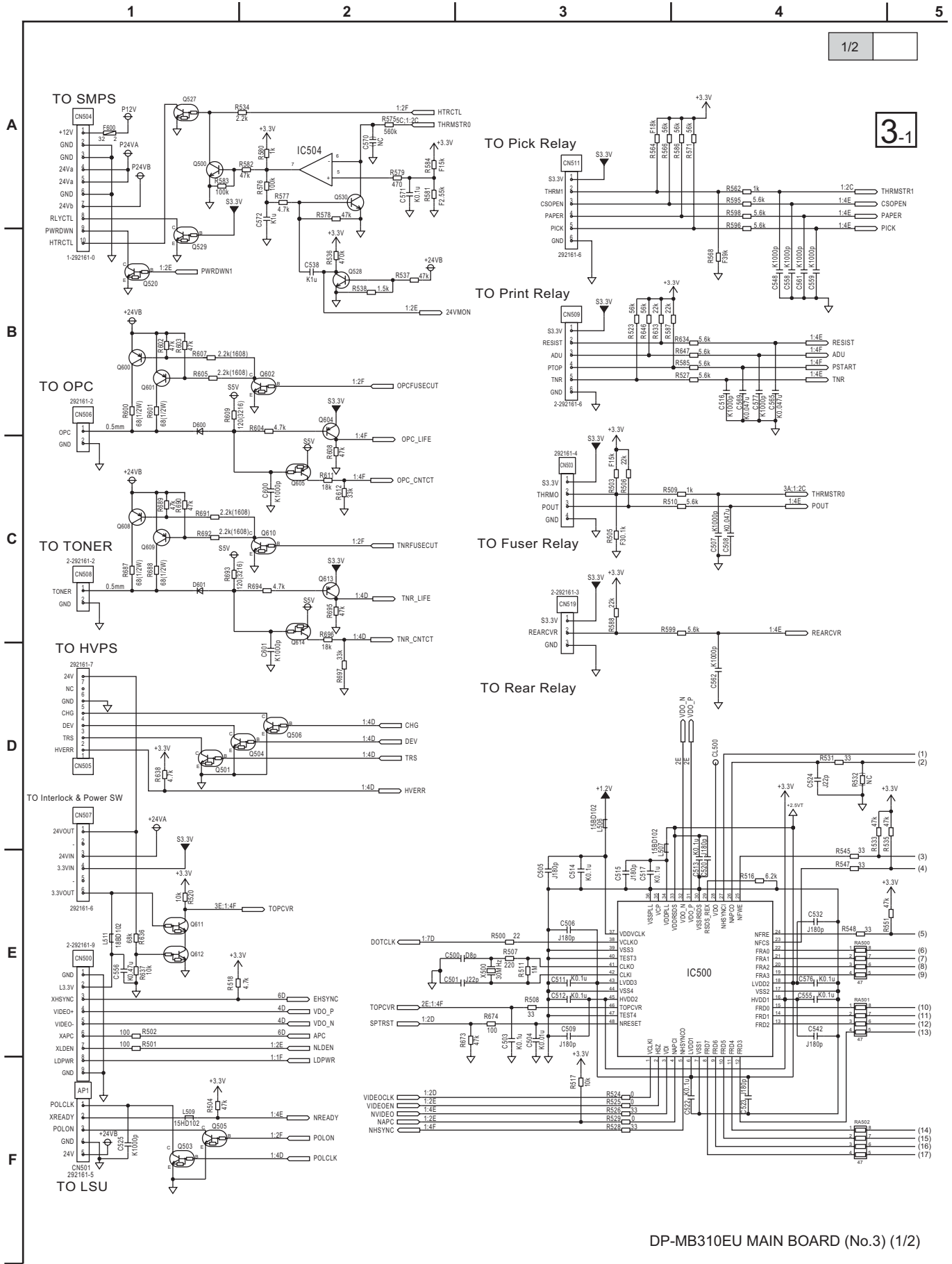

5

6

7

8

2/2

3-2

A

B

C

D

E

F

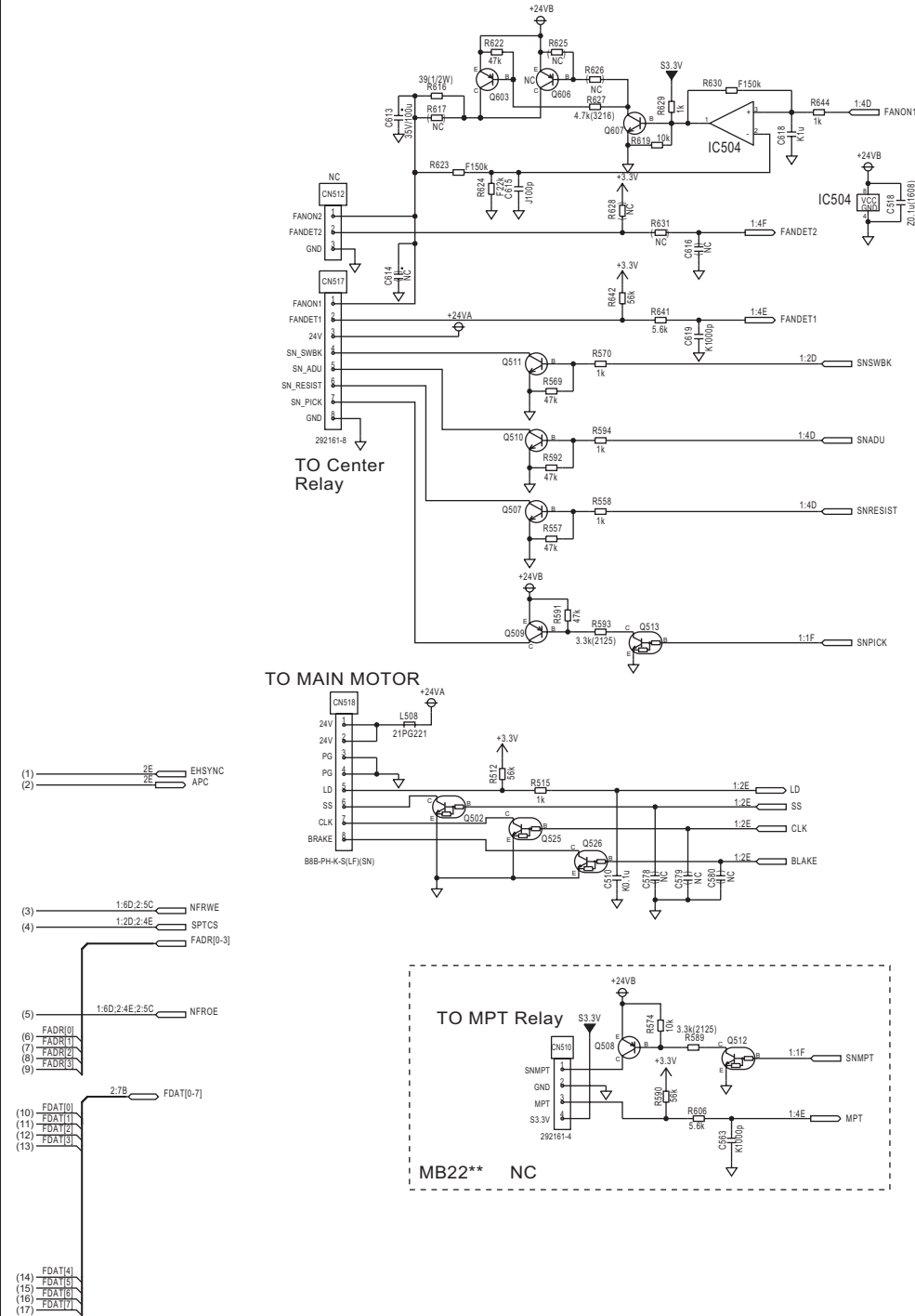

DP-MB310EU MAIN BOARD (No.3) (2/2)

16.7.4. Main Board(4)

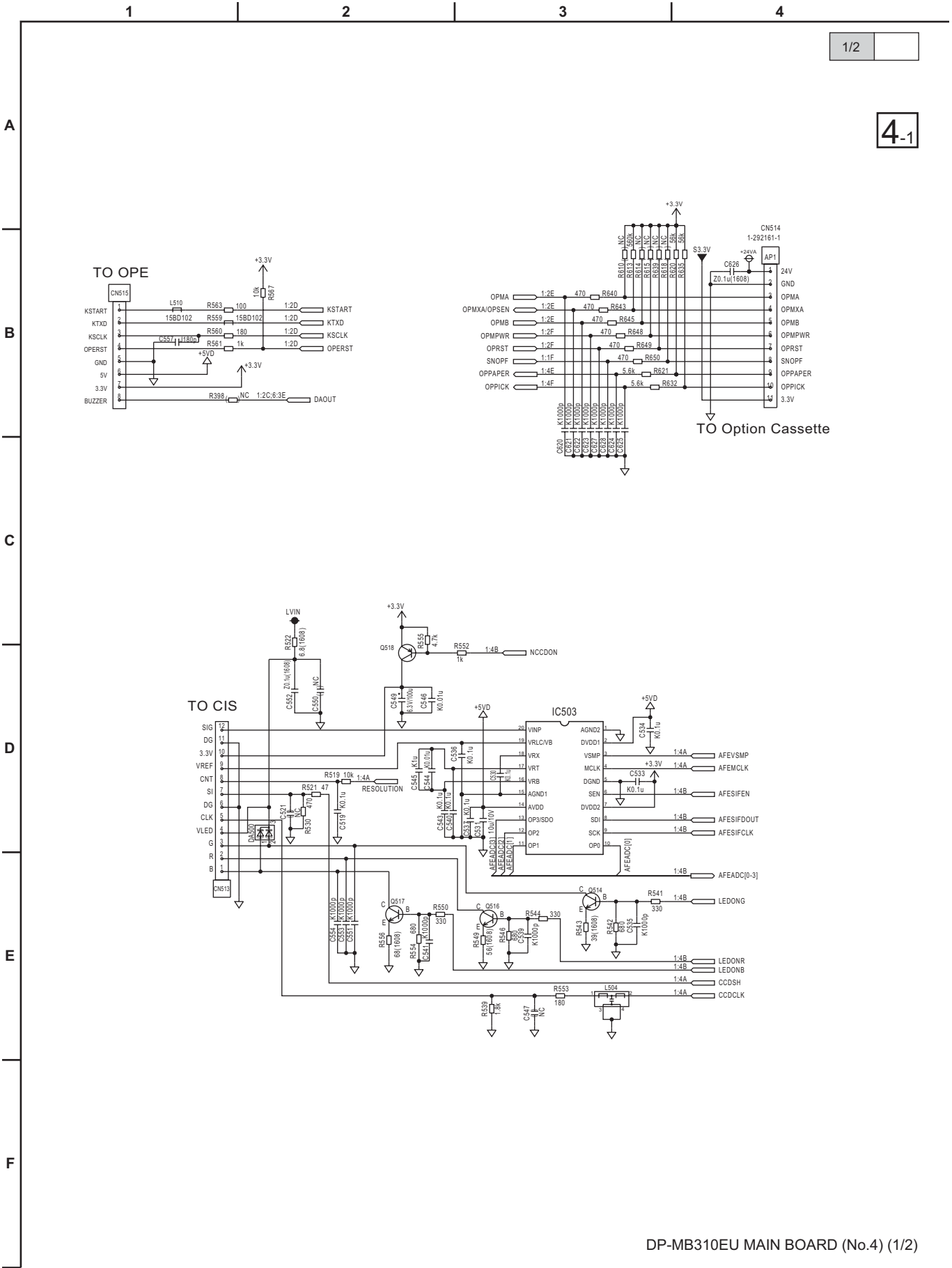

1/2

4.1

DP-MB310EU MAIN BOARD (No.4) (1/2)

5

6

7

8

2/2

4-2

A

B

C

D

E

F

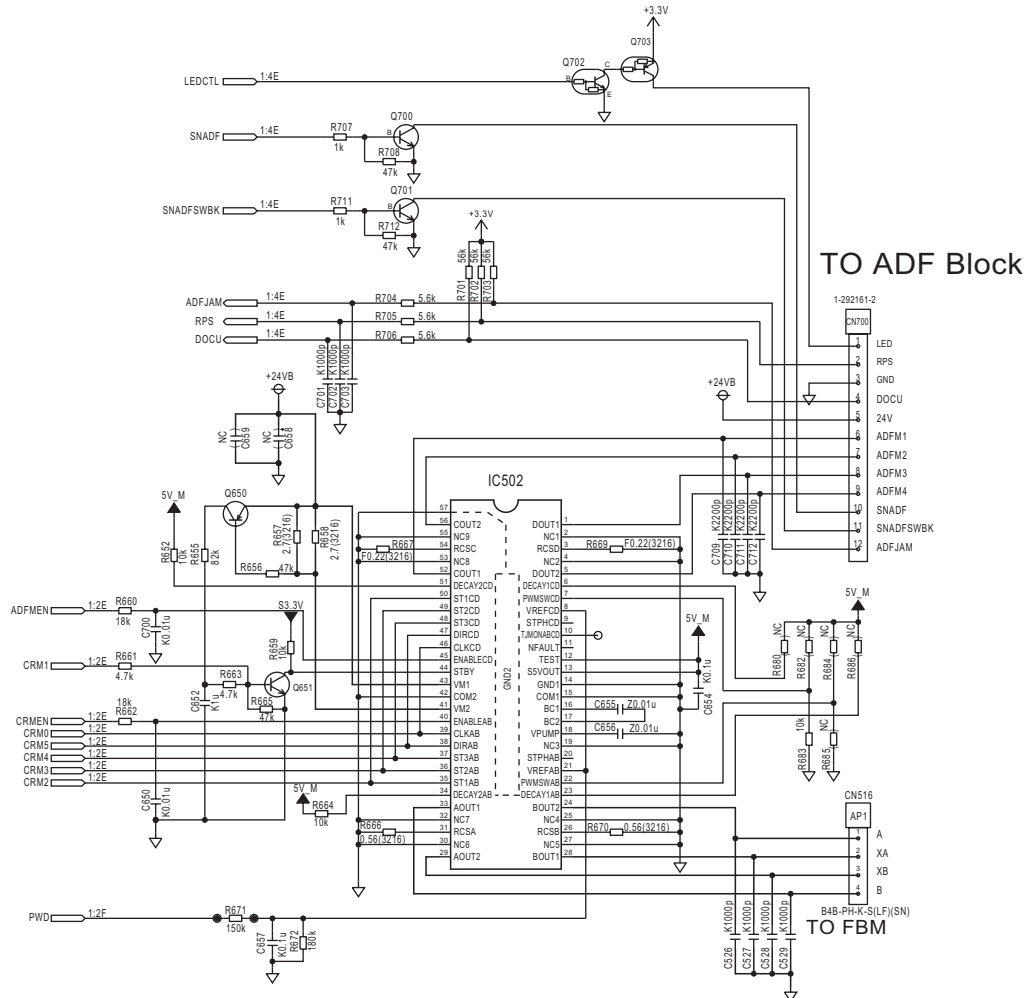

DP-MB310EU MAIN BOARD (No.4) (1/2)

16.7.5. Main Board(5)

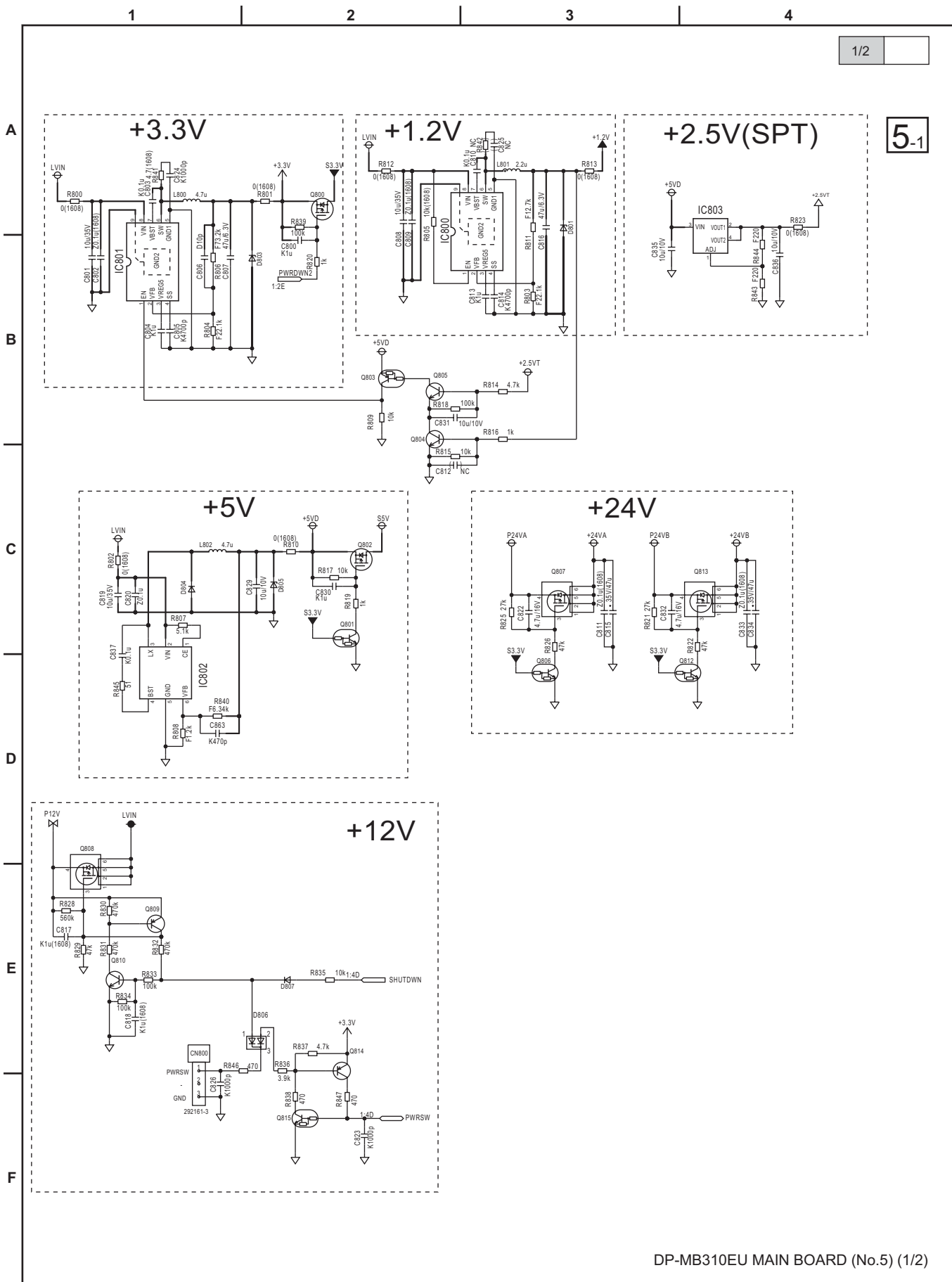

DP-MB310EU MAIN BOARD (No.5) (1/2)

16.7.6. Main Board(6)

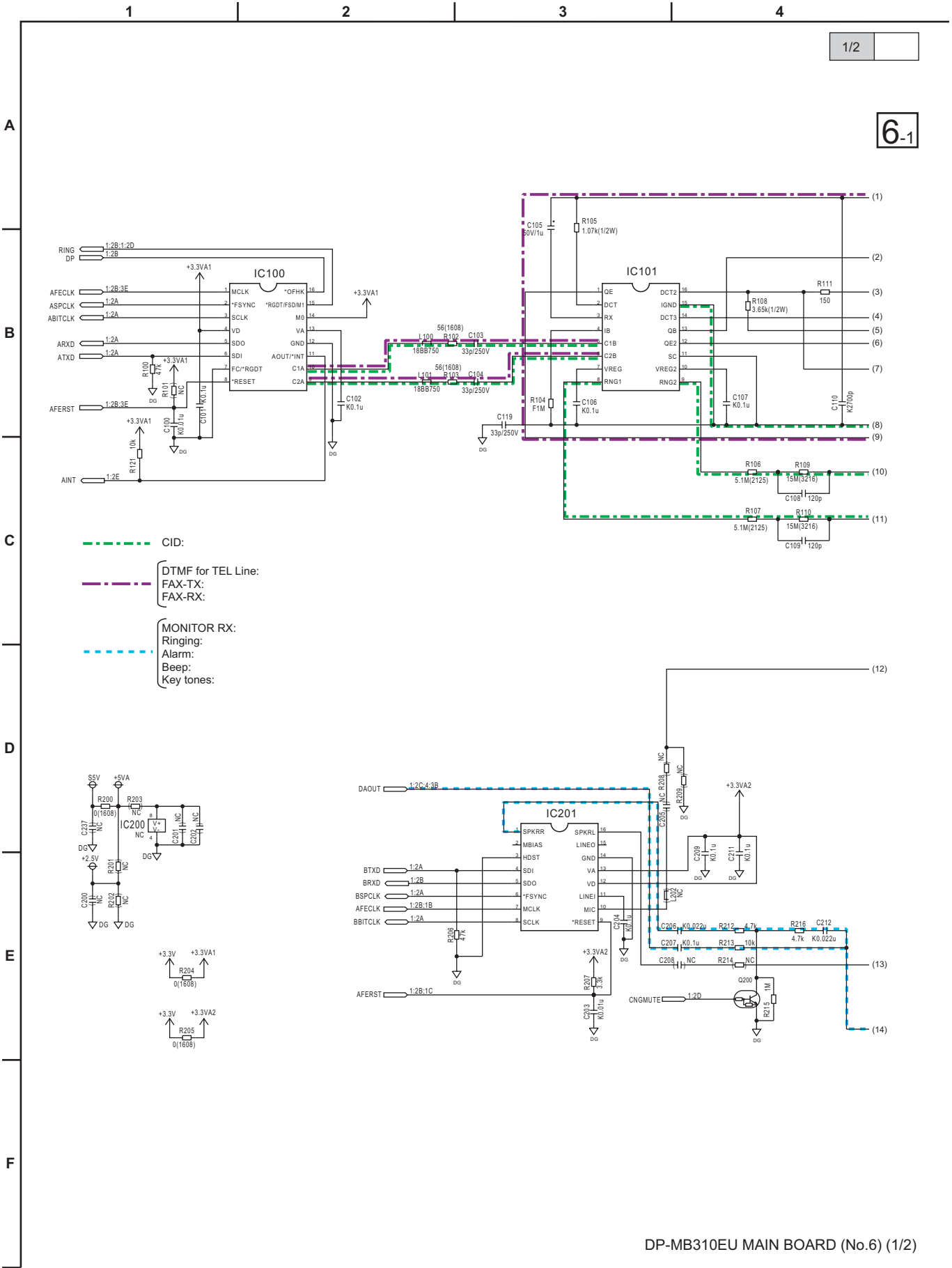

DP-MB310EU MAIN BOARD (No.6) (1/2)

6-2

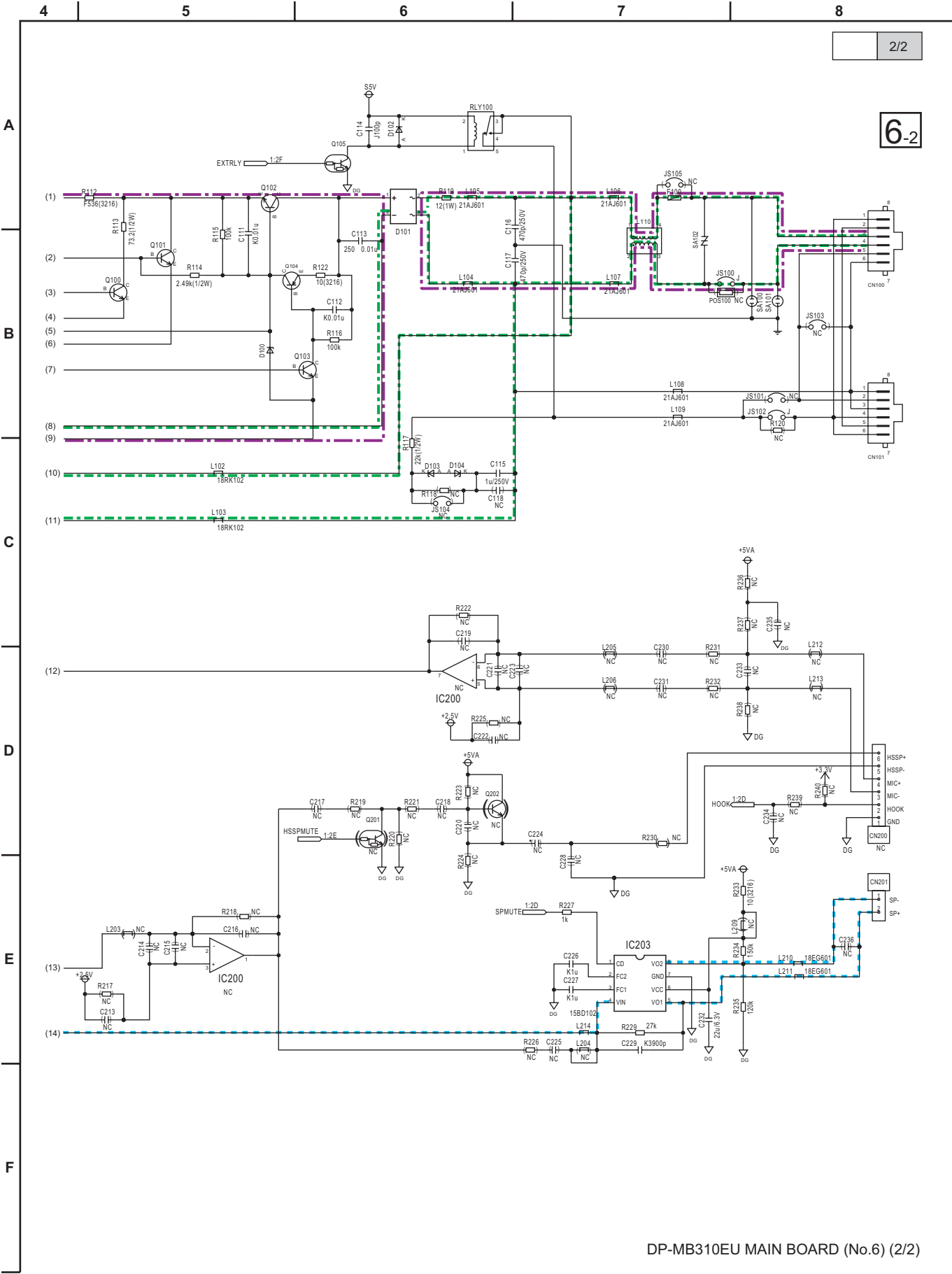

DP-MB310EU MAIN BOARD (No.6) (2/2)

16.8. Sensor Board (KX-MB2230)

16.8.1. Operation Board

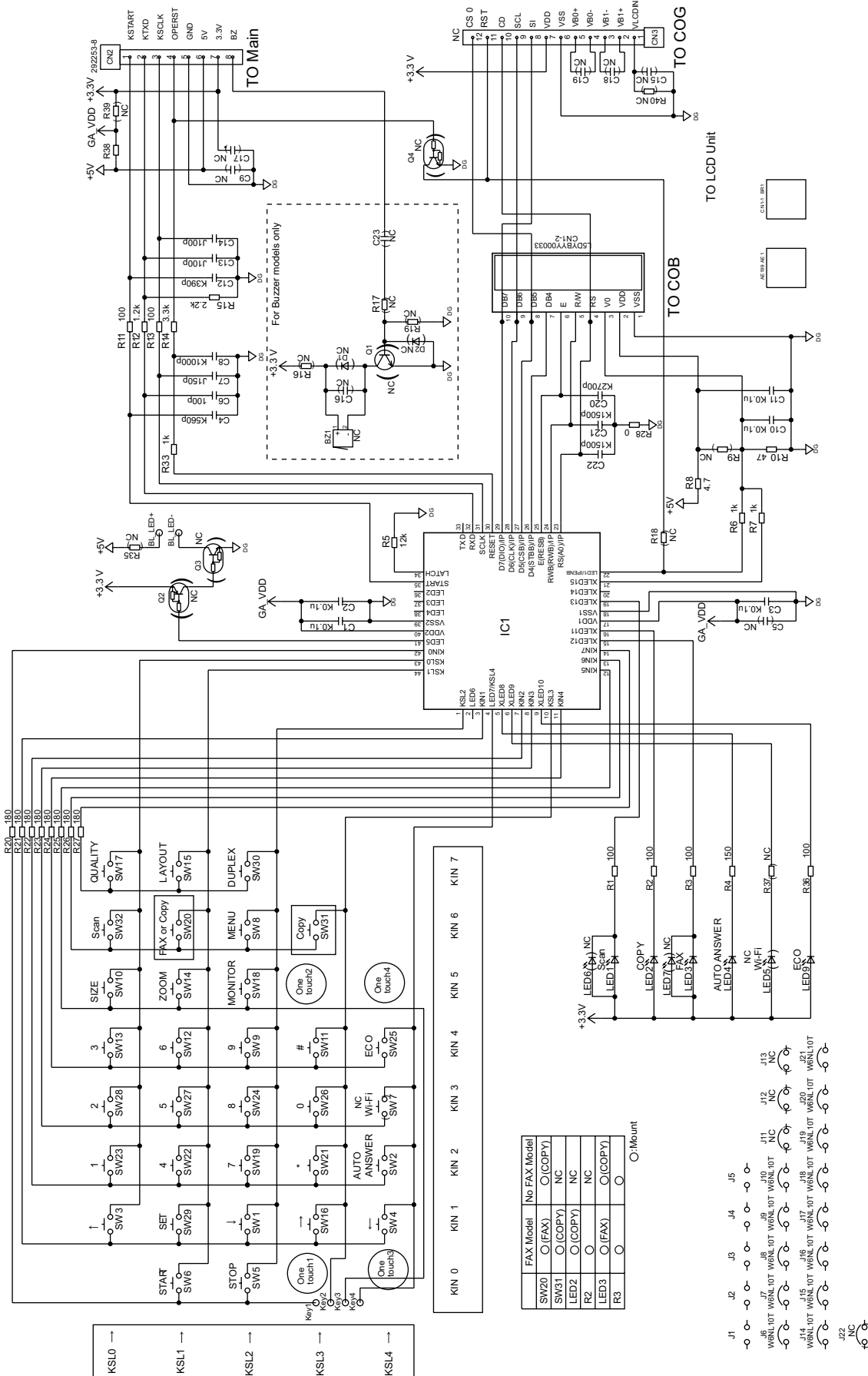

16.9. Sensor Board (KX-MB2270)

16.9.1. Operation Board

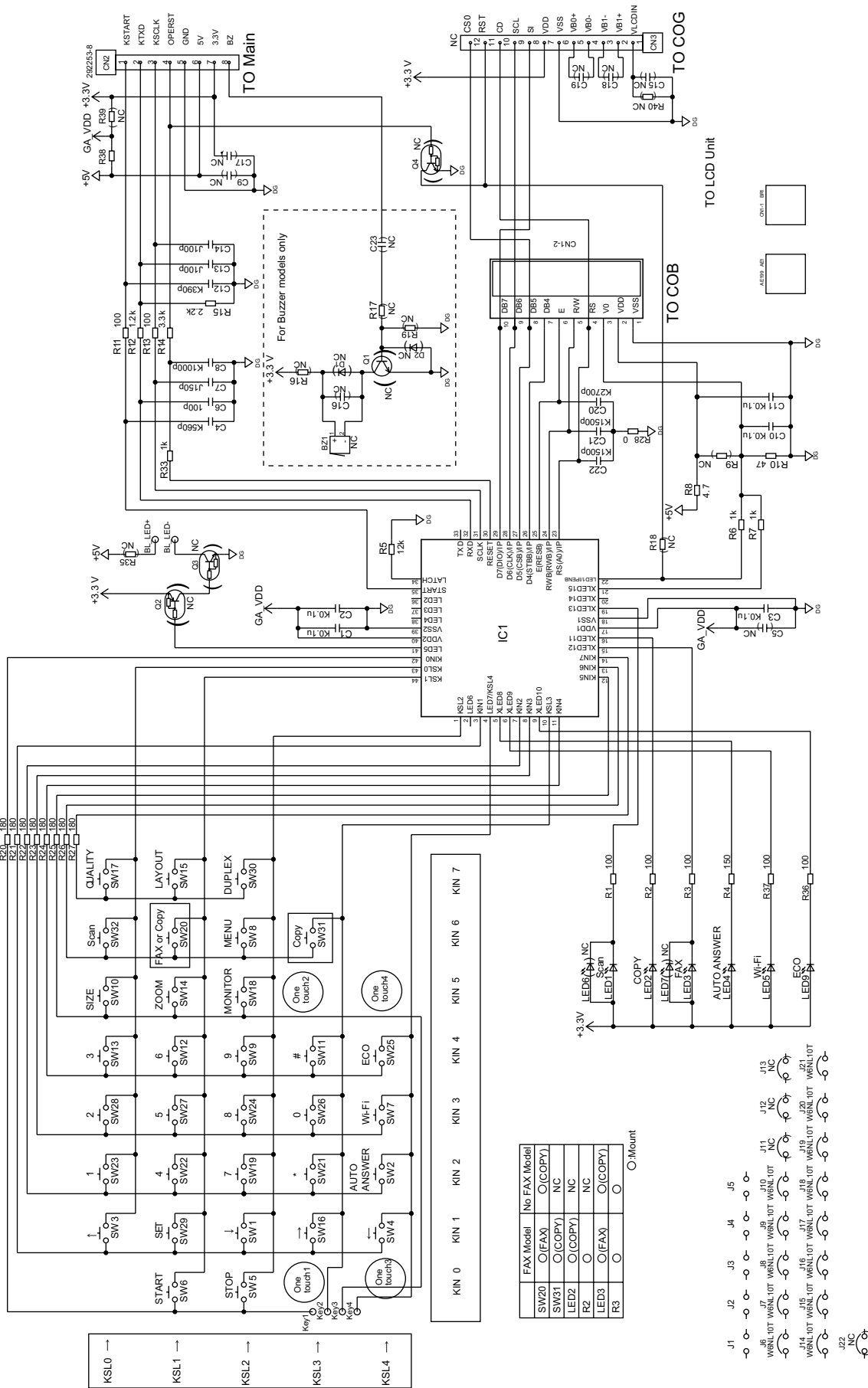

KX-MB2270EU OPERATION BOARD

16.9.2. Sensor Board

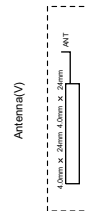
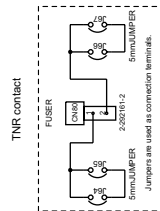
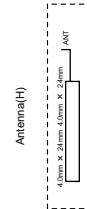
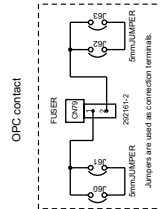
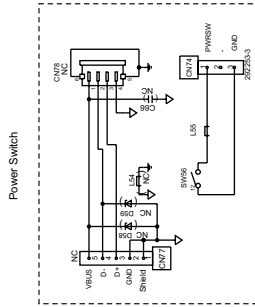
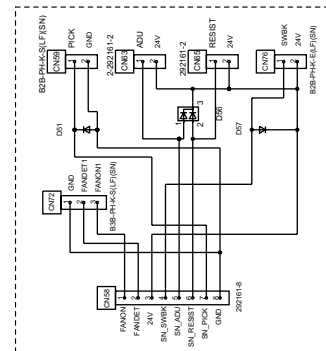
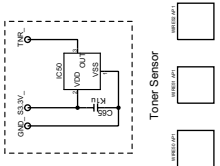
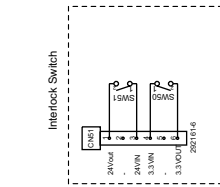
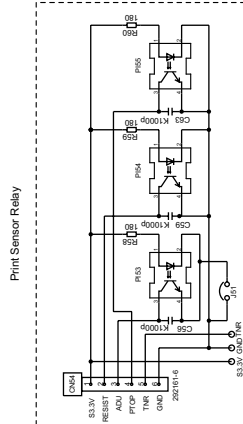
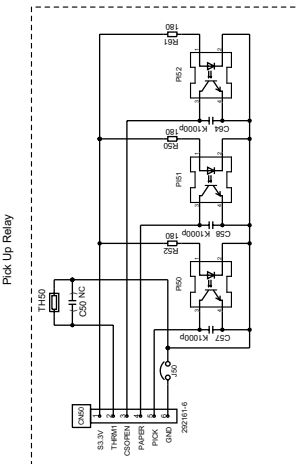
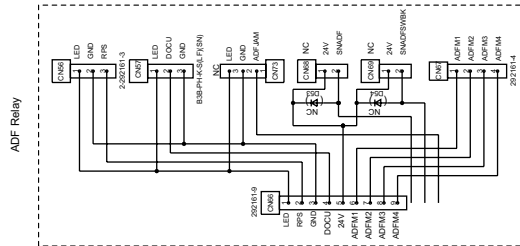
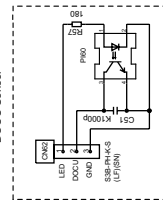
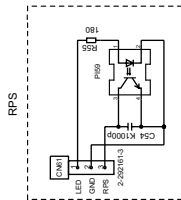
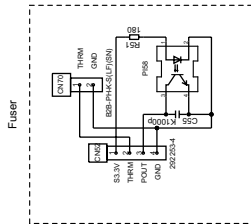
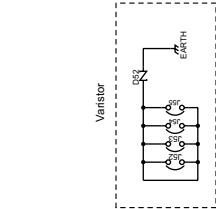
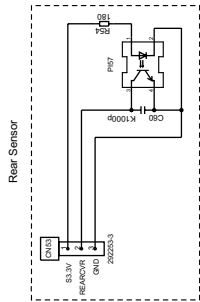

16.10. Sensor Board (KX-MB2515)

16.10.1. Operation Board

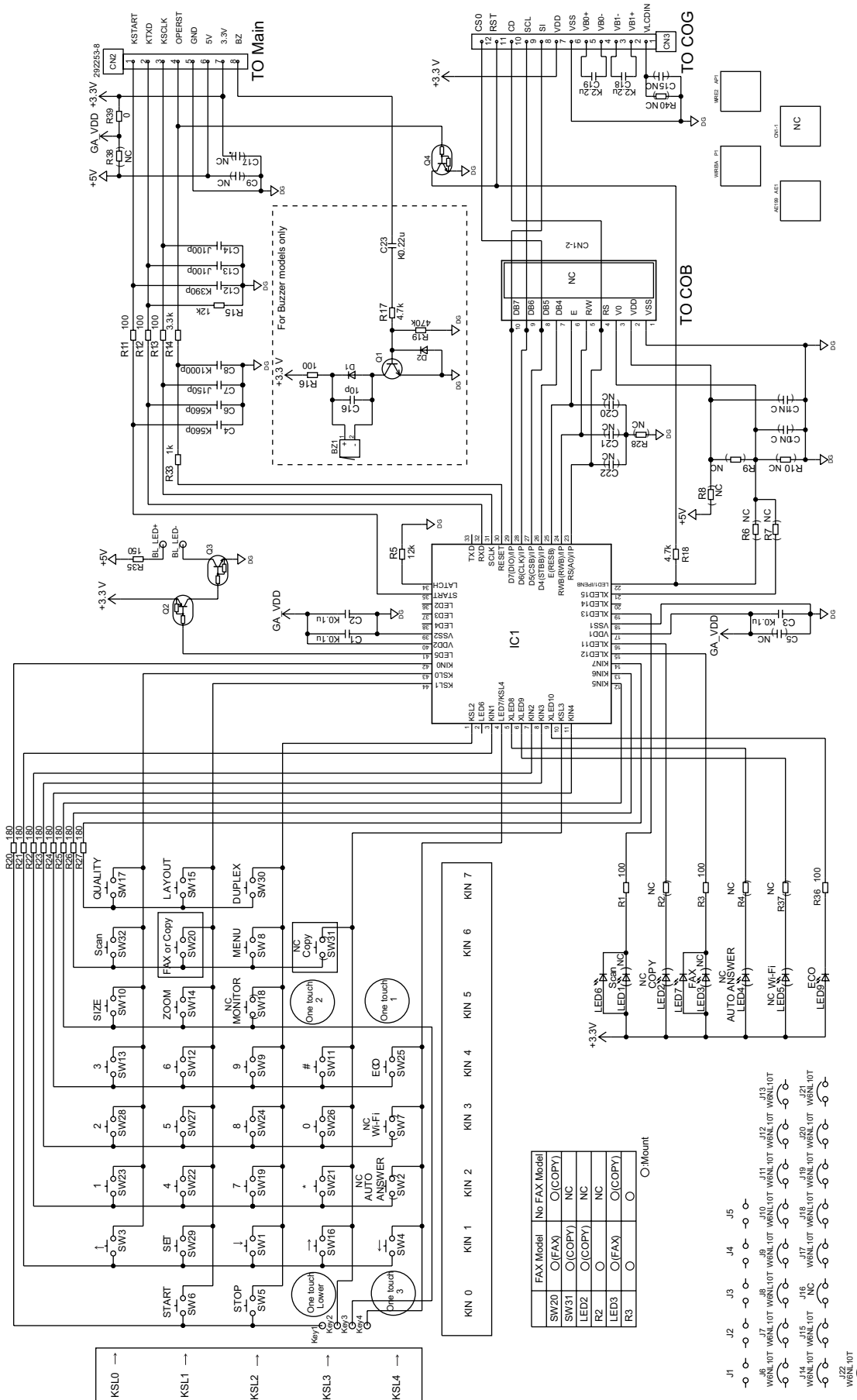

FAX Model	No FAX Model
SW20	O (FAX) O (COPY)
SW31	O (COPY) NC
LED2	O (COPY) NC
R2	O (COPY) NC
LED3	O (FAX) O (COPY)
R3	O O Mount

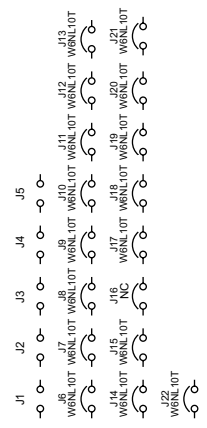

16.10.2. Sensor Board

KX-MB2515EU SENSOR BOARD

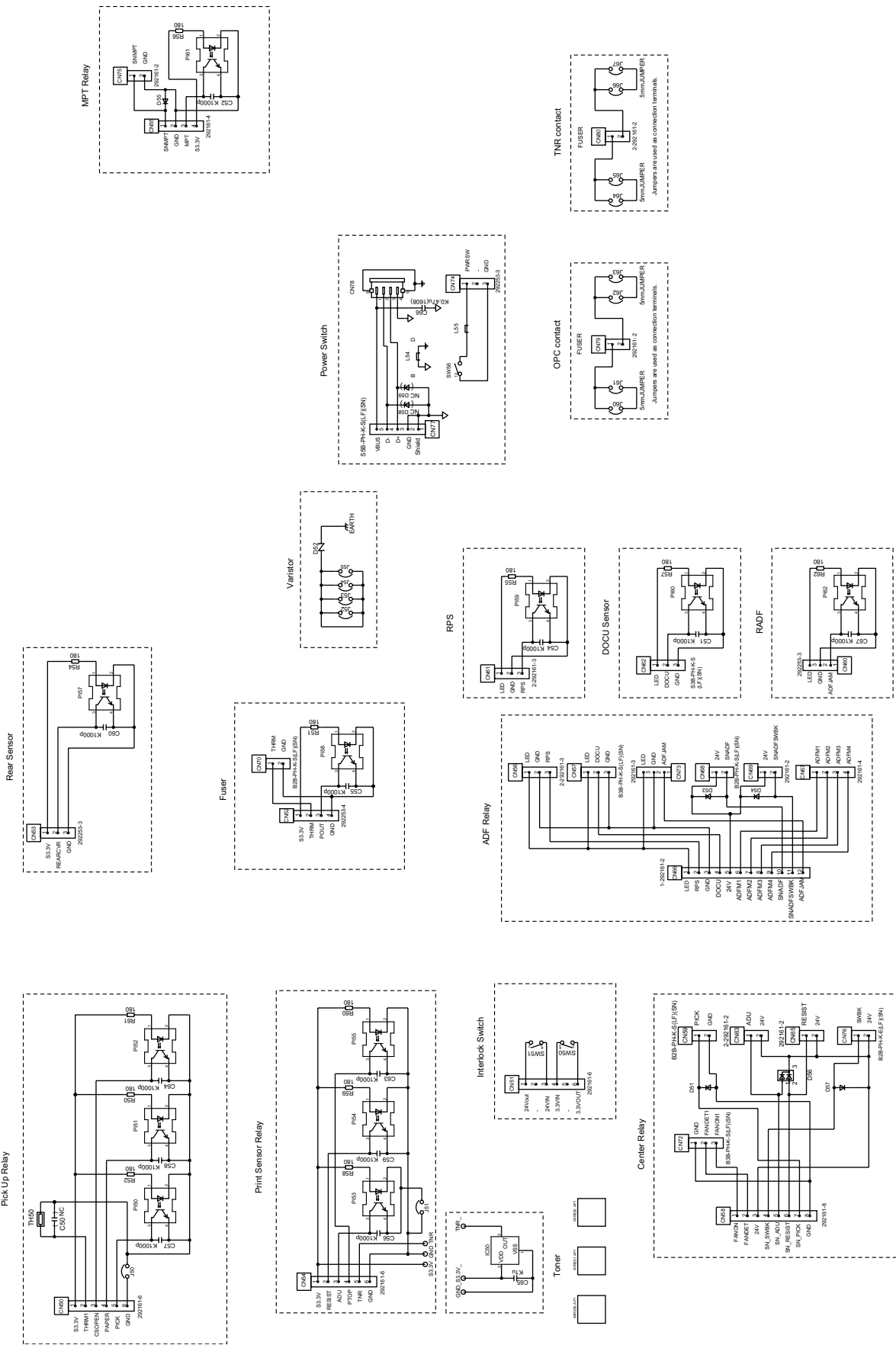

16.11. Sensor Board (KX-MB2545)

16.11.1. Operation Board

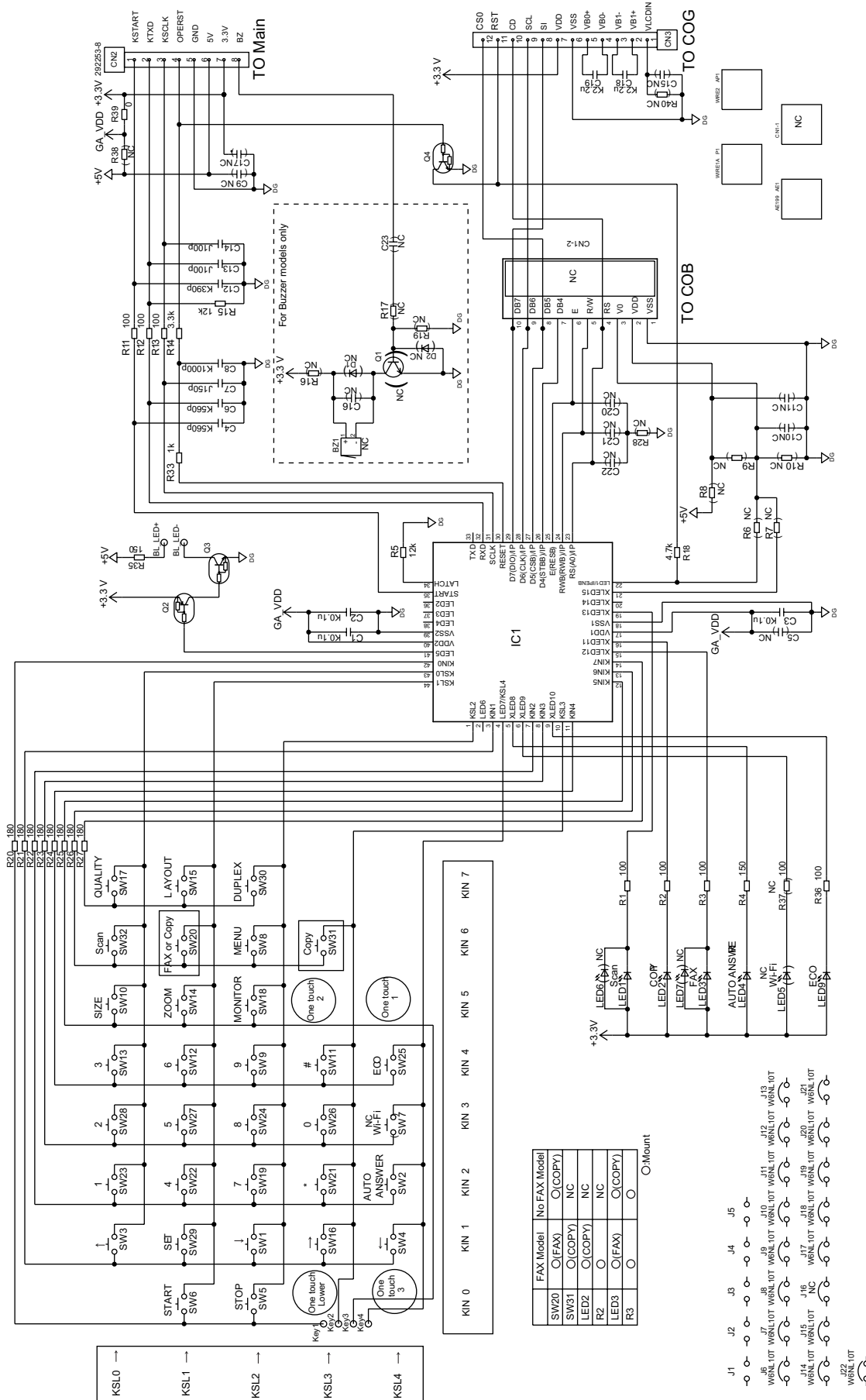

16.11.2. Sensor Board

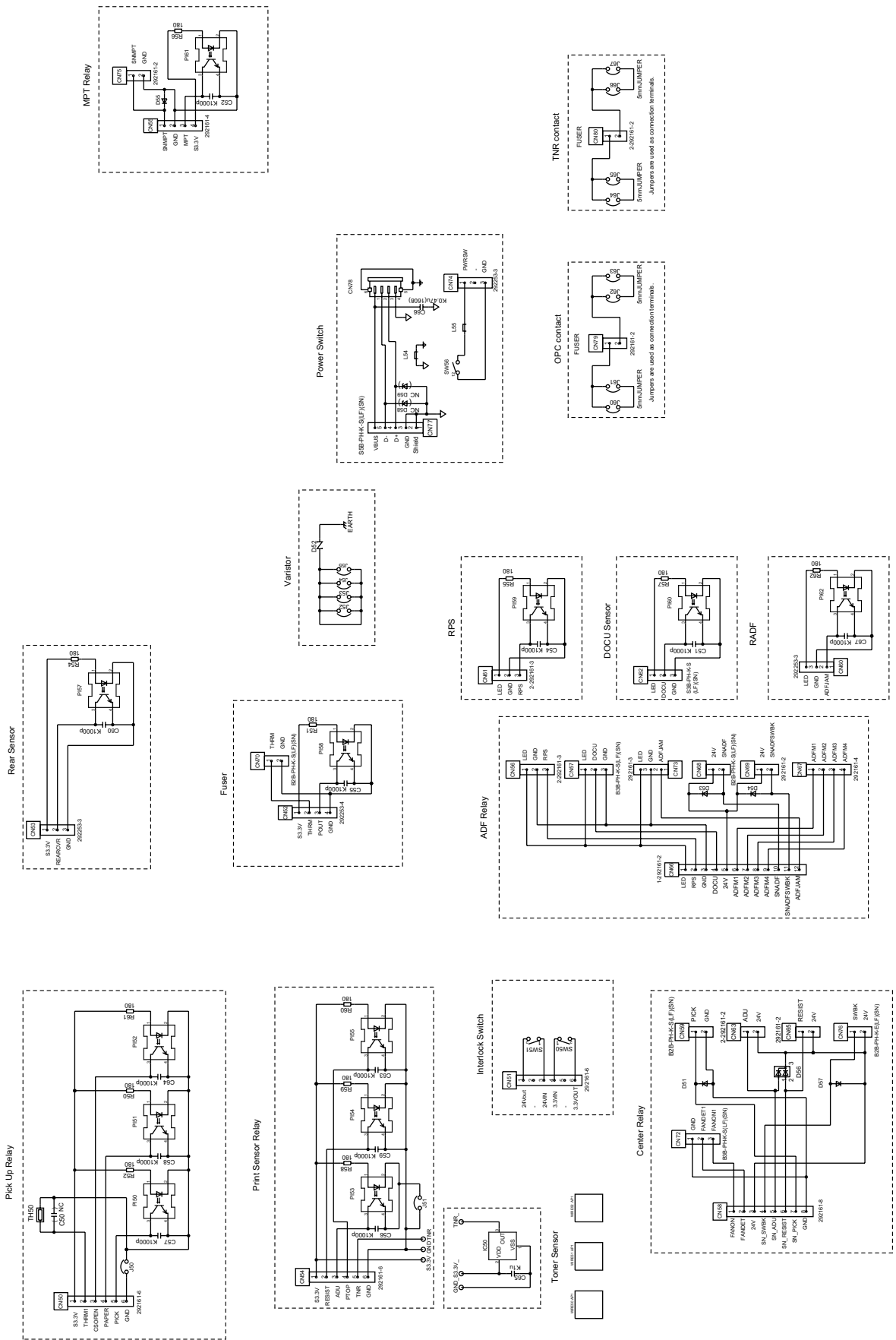

16.12. Sensor Board (KX-MB2575)

16.12.1. Operation Board

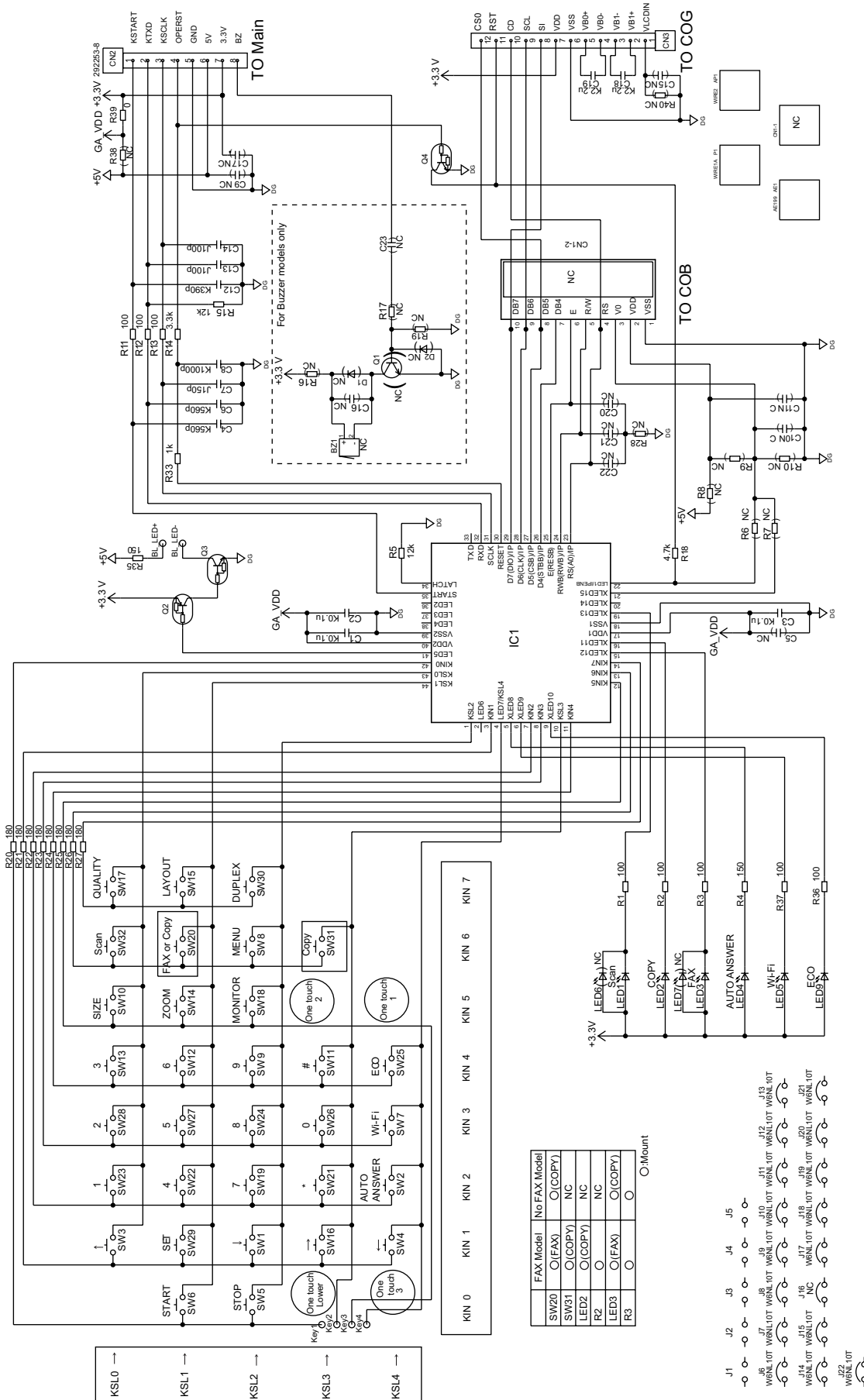

16.12.2. Sensor Board

KX-MB2575EU SENSOR BOARD

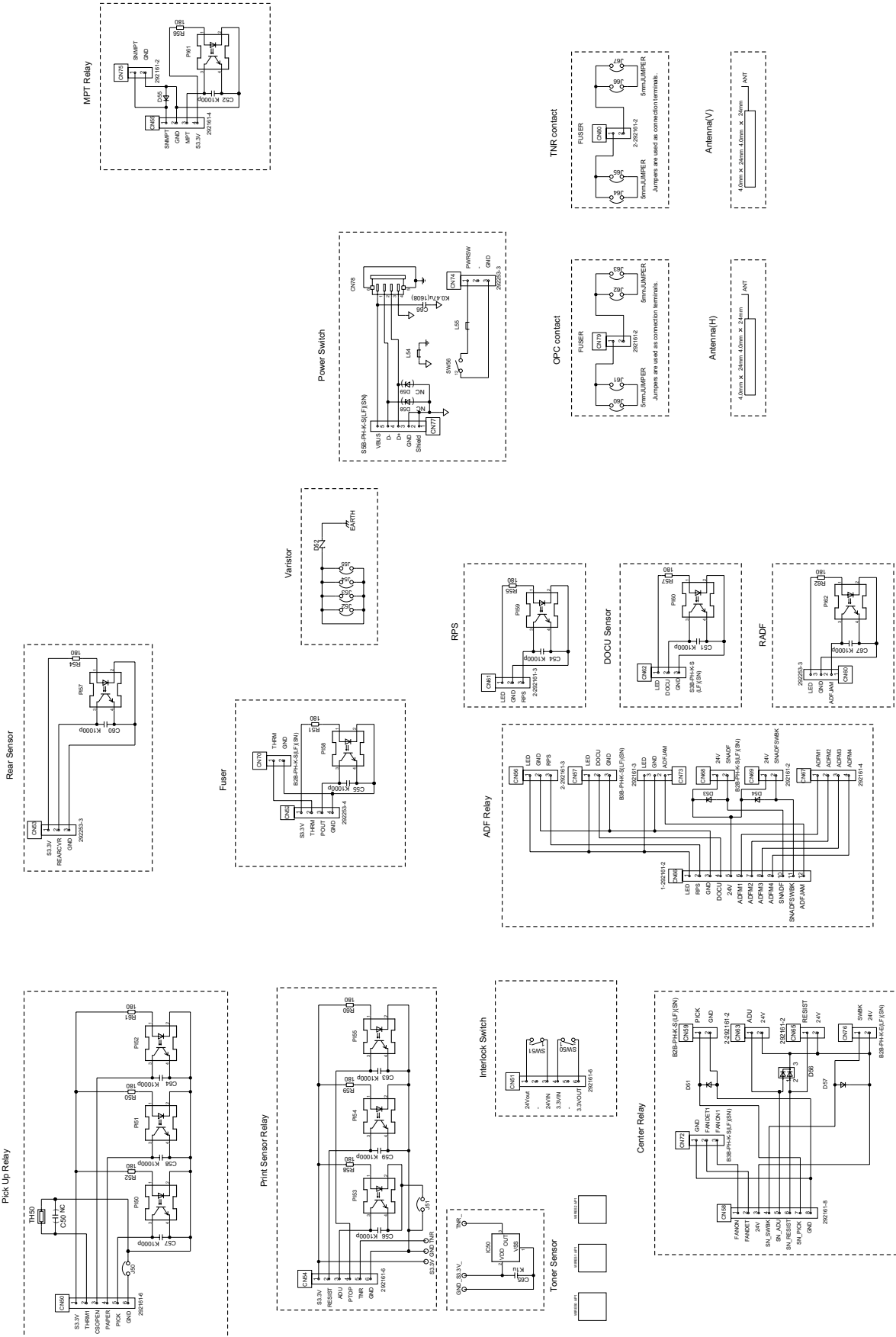

16.13. Sensor Board (DP-MB310)

16.13.1. Operation Board

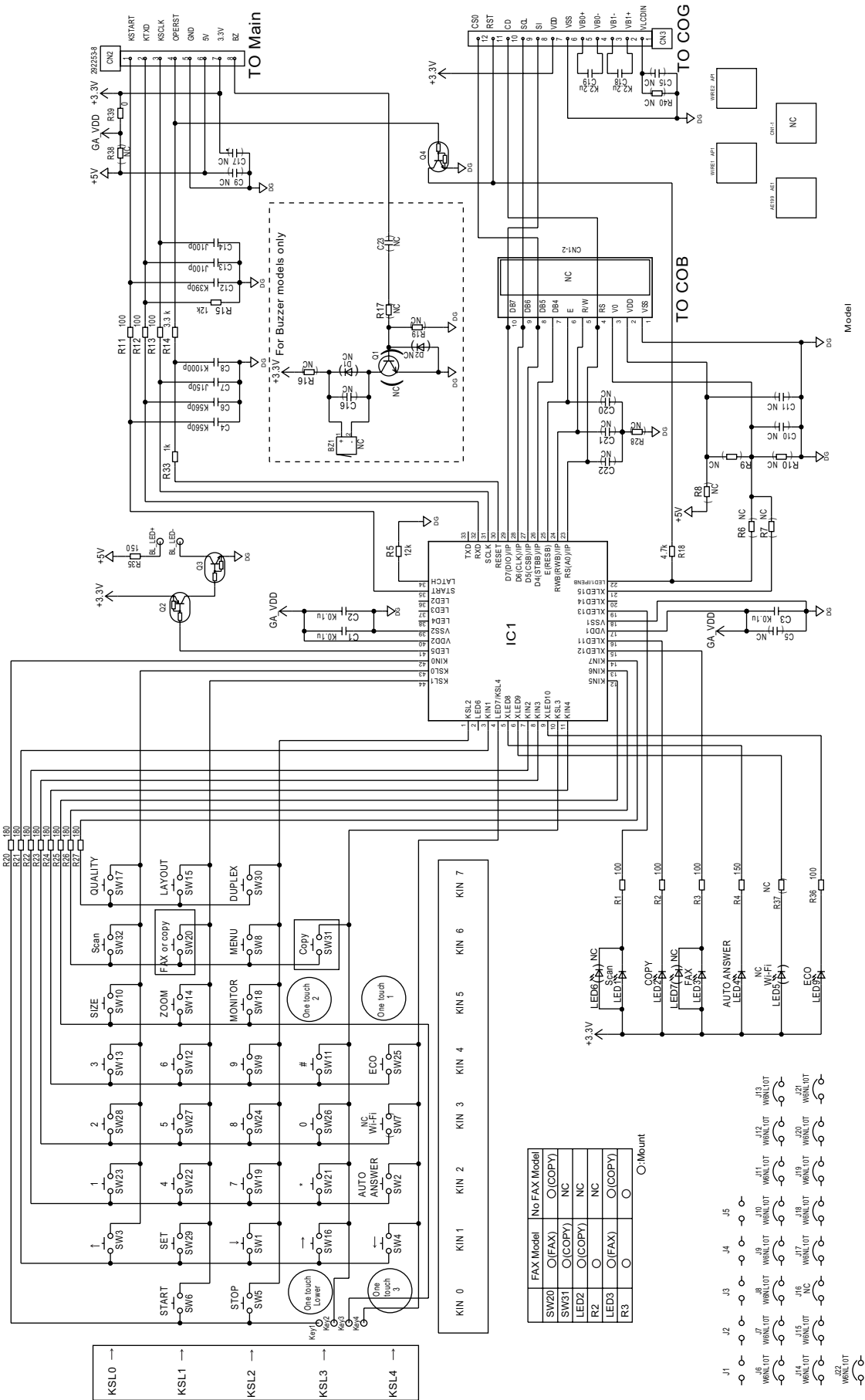

DP-MB310EU OPERATION BOARD

16.13.2. Sensor Board

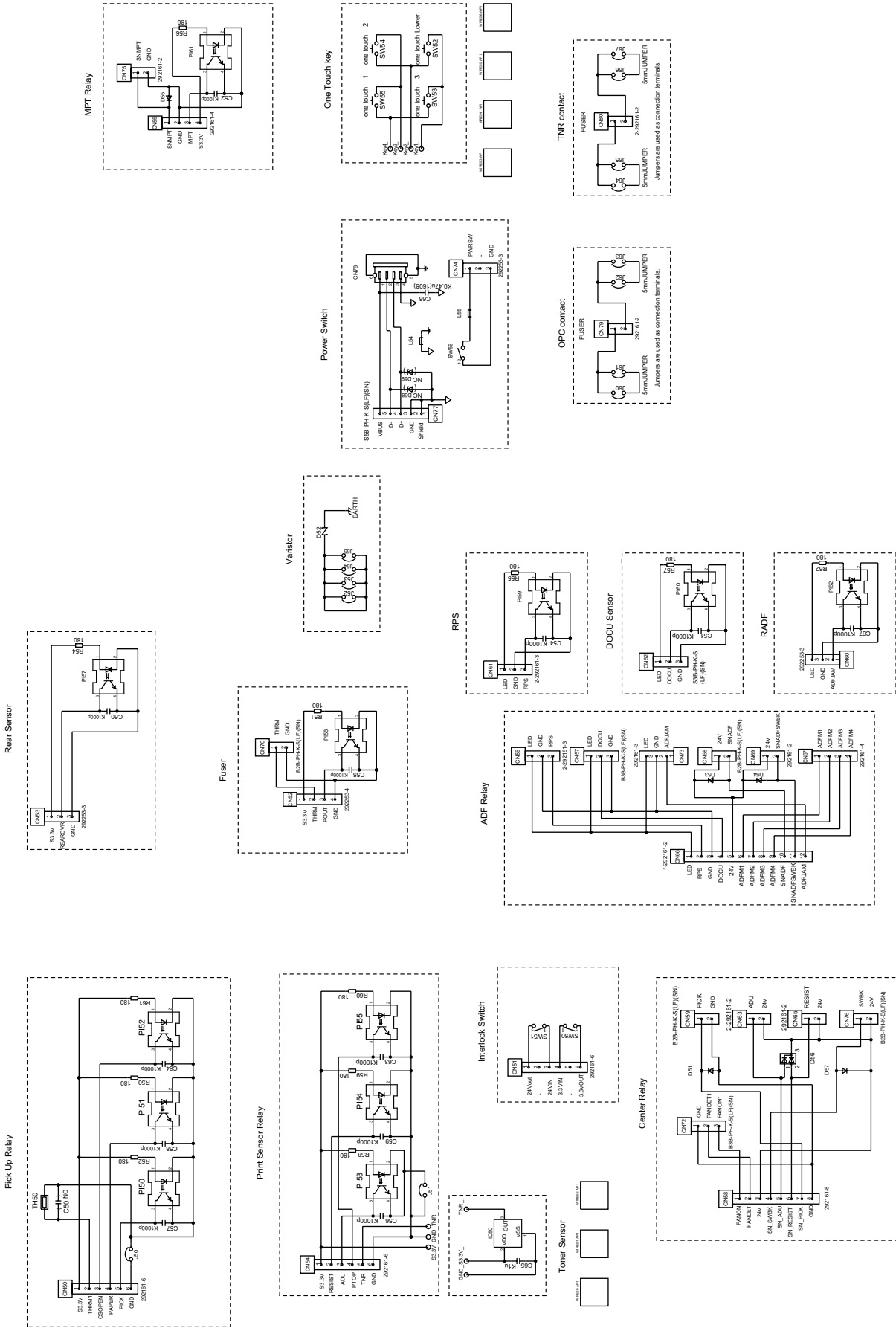

DP-MB310EU SENSOR BOARD

16.14. Back Light Board

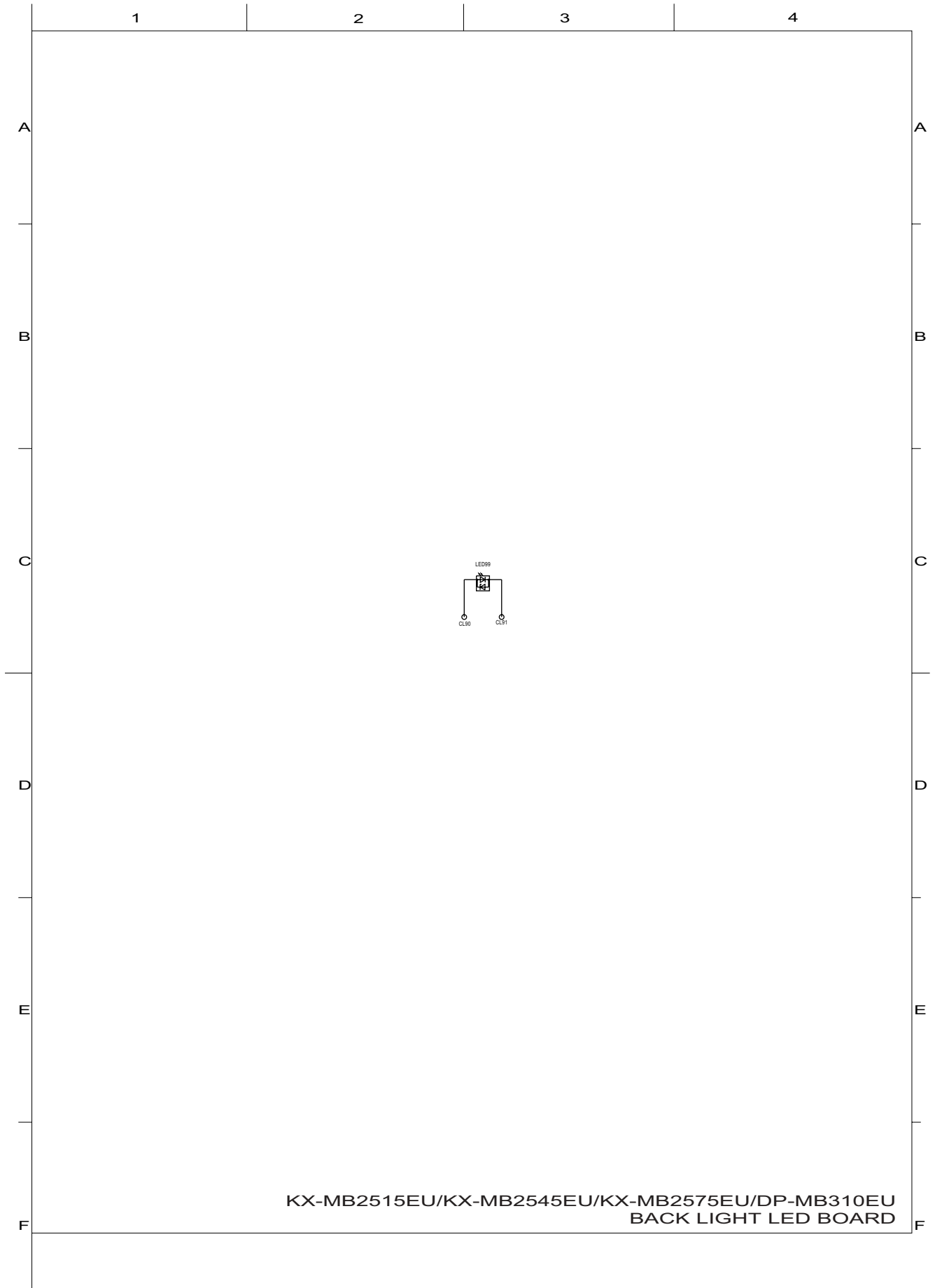

16.15. High Voltage Power Supply Board (HVPS Board)

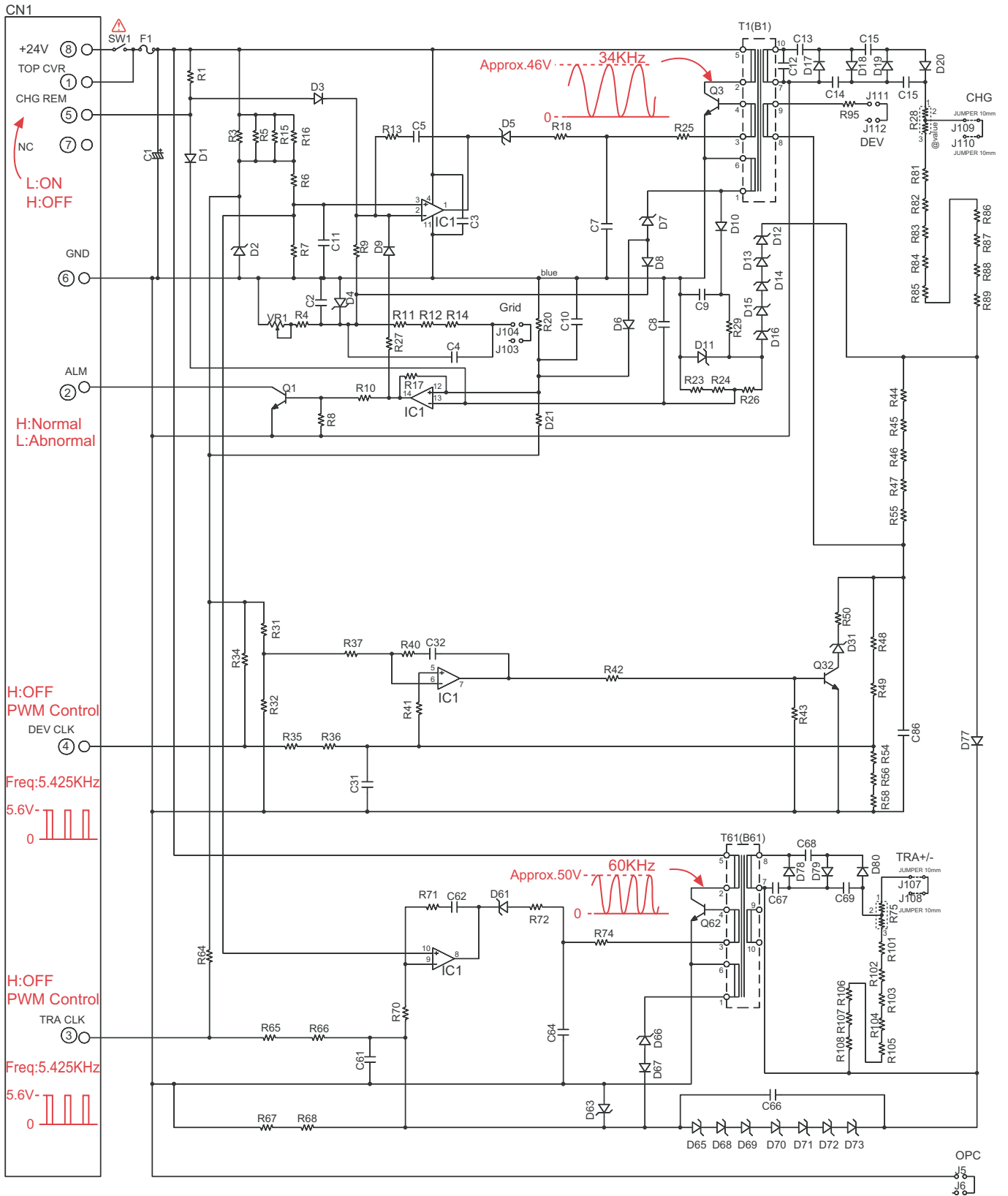

KX-MB2230EU / KX-MB2270EU / KX-MB2515EU / KX-MB2545EU / KX-MB2575EU / DP-MB310EU
HIGH VOLTAGE POWER SUPPLY BOARD

16.16. Low Voltage Power Supply Board (SMPS Board)

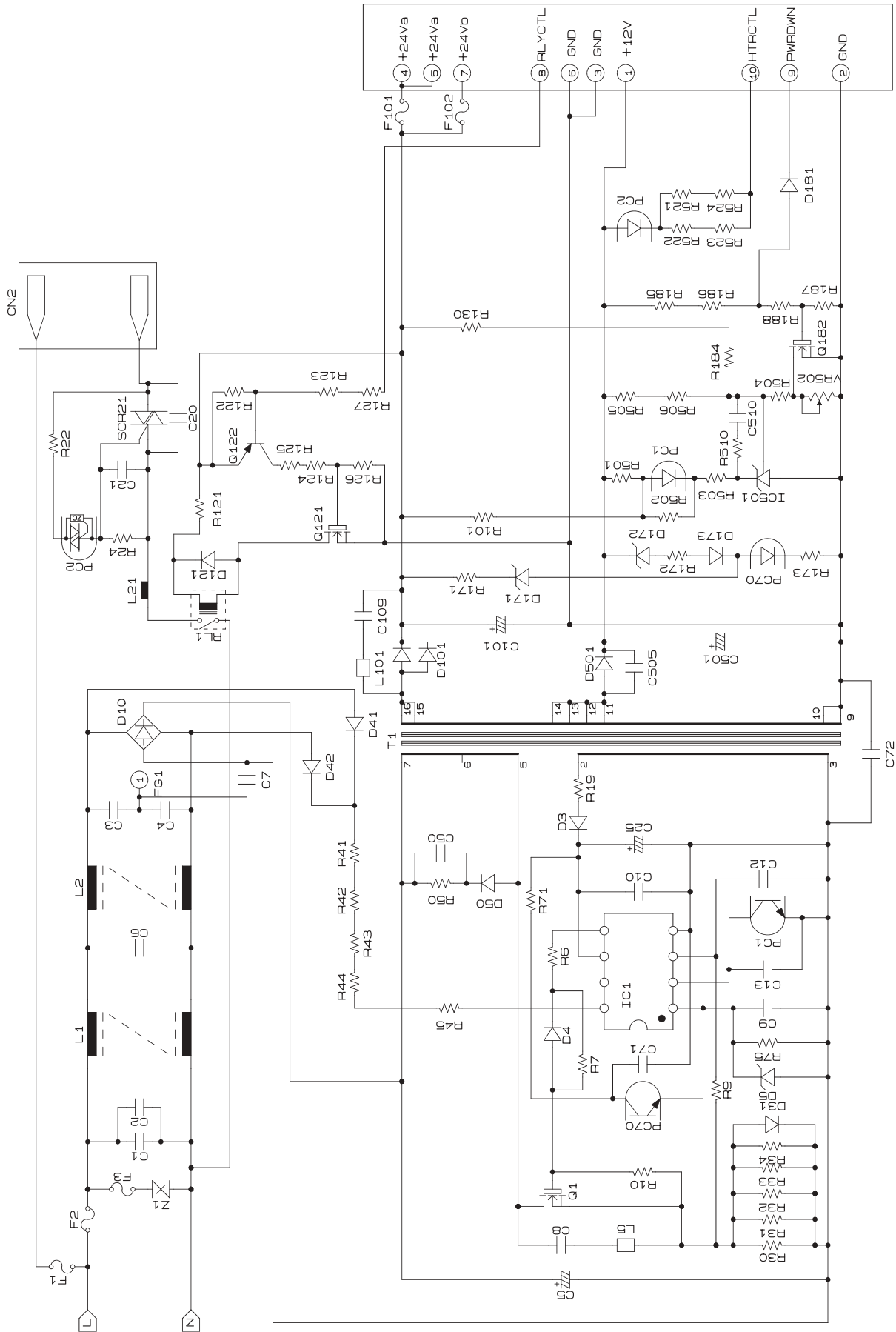

MPW3135

KX-MB2230EU / KX-MB2270EU / KX-MB2515EU / KX-MB2545EU / KX-MB2575EU / DP-MB310EU
LOW VOLTAGE POWER SUPPLY BOARD

Memo

17 Printed Circuit Board

17.1. Main Board

17.1.1. Main Board: Component View

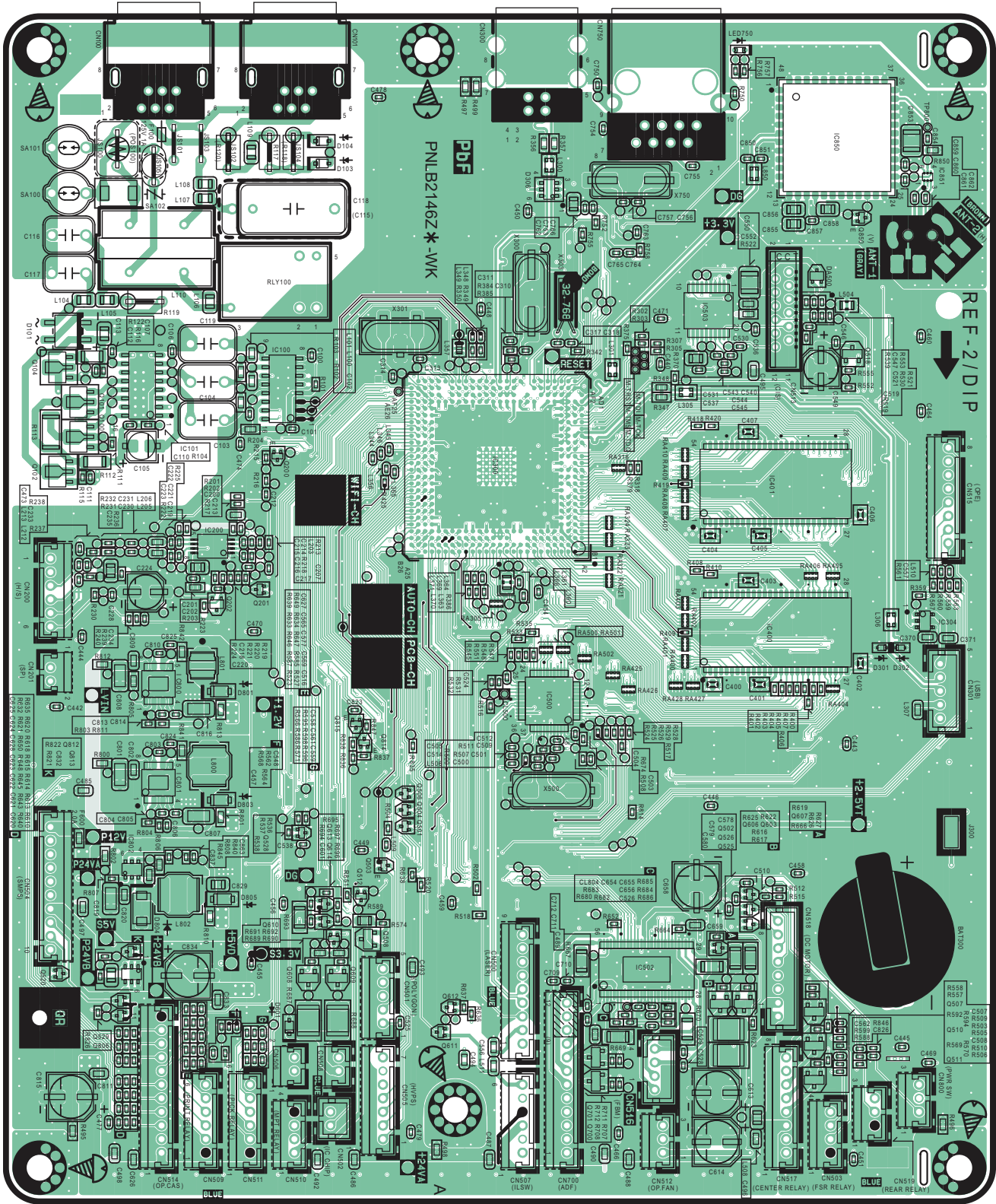

KX-MB2230EU / KX-MB2270EU / KX-MB2515EU / KX-MB2545EU / KX-MB2575EU / DP-MB310EU
MAIN BOARD COMPONENT VIEW

17.1.2. Main Board: Bottom View

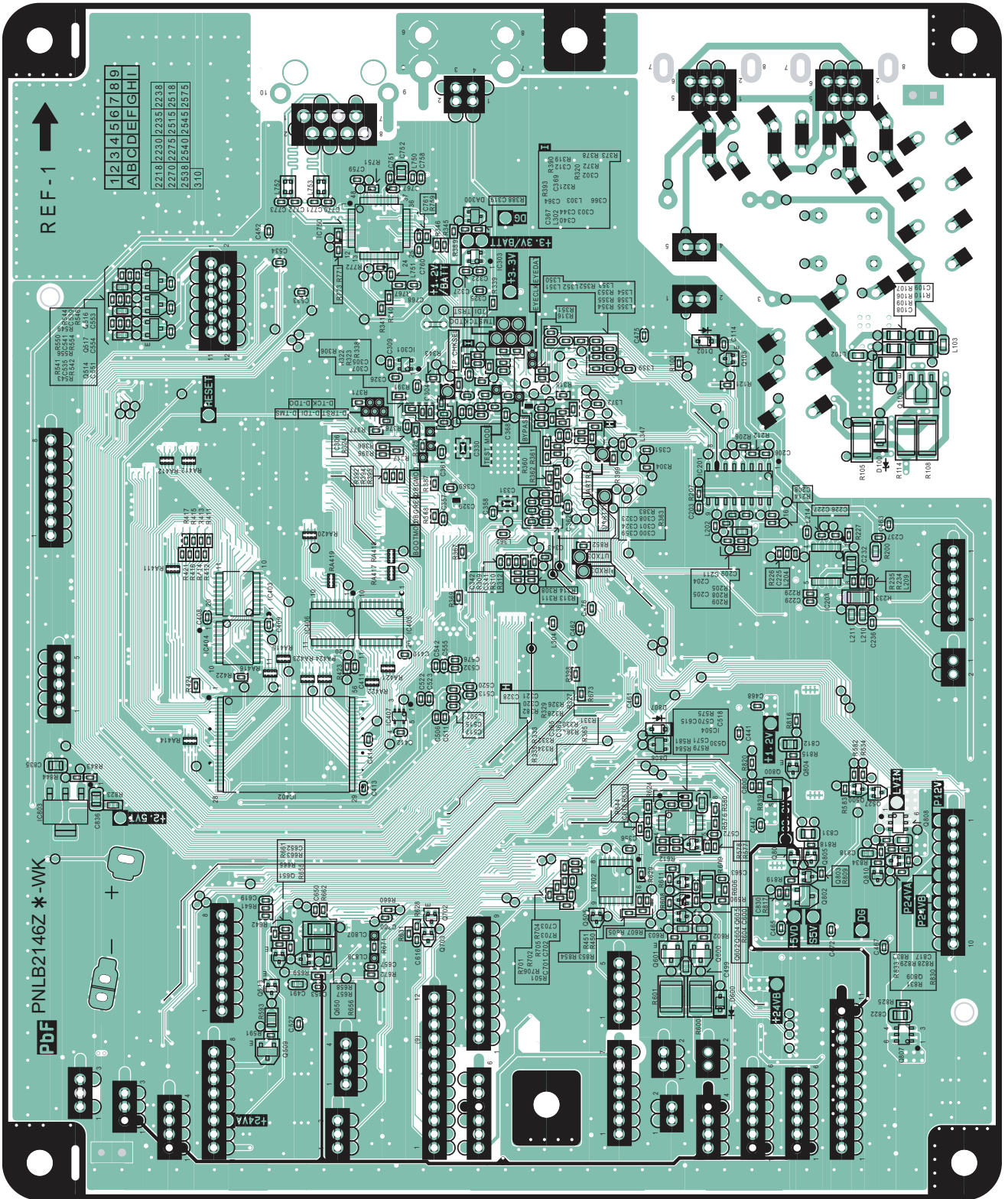

KX-MB2230EU / KX-MB2270EU / KX-MB2515EU / KX-MB2545EU / KX-MB2575EU / DP-MB310EU
MAIN BOARD BOTTOM VIEW

17.2. Sensor Board

17.2.1. Operation Board

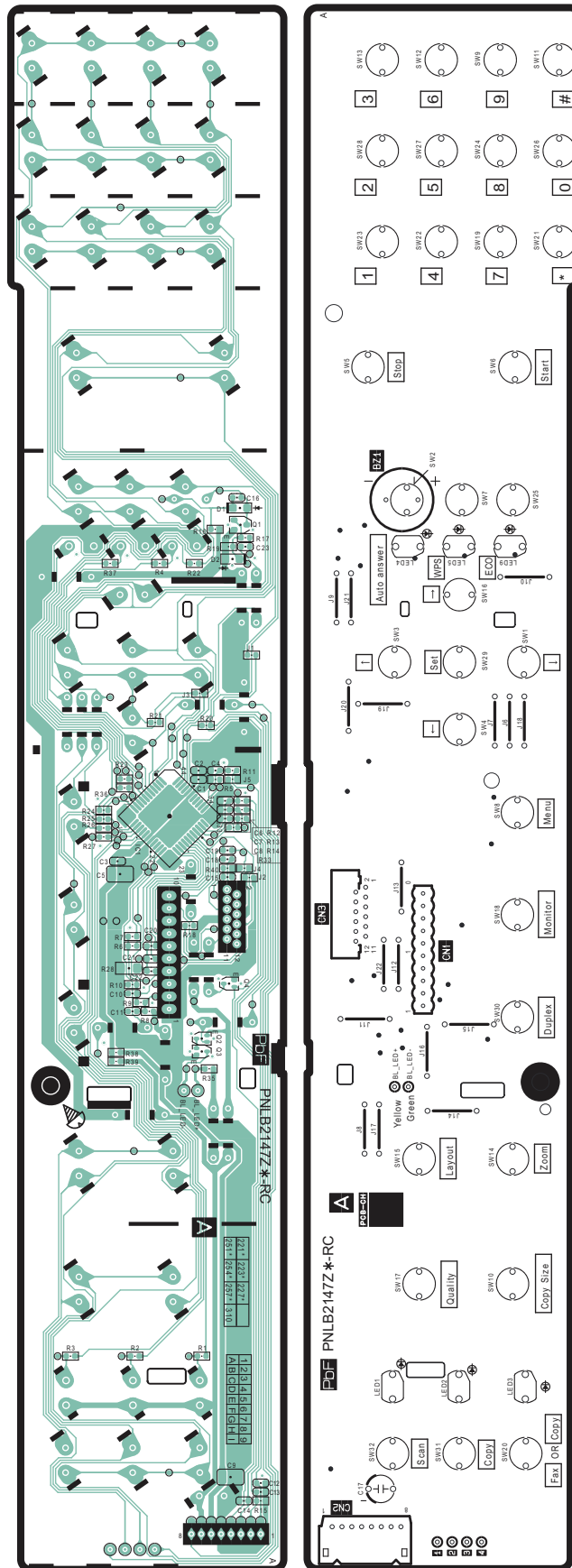

KX-MB2230EU / KX-MB2270EU / KX-MB2515EU / KX-MB2545EU / KX-MB2575EU / DP-MB310EU
OPERATION PANEL BOARD

17.2.2. PICK UP RELAY Board

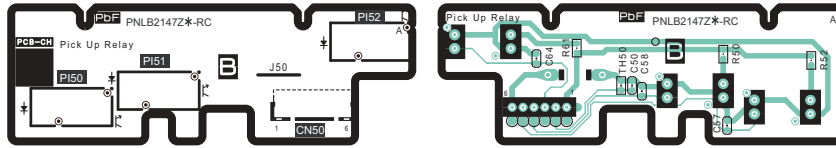

KX-MB2230EU / KX-MB2270EU / KX-MB2515EU / KX-MB2545EU / KX-MB2575EU / DP-MB310EU
PICK UP RELAY BOARD

17.2.3. PRINT SENSOR RELAY Board

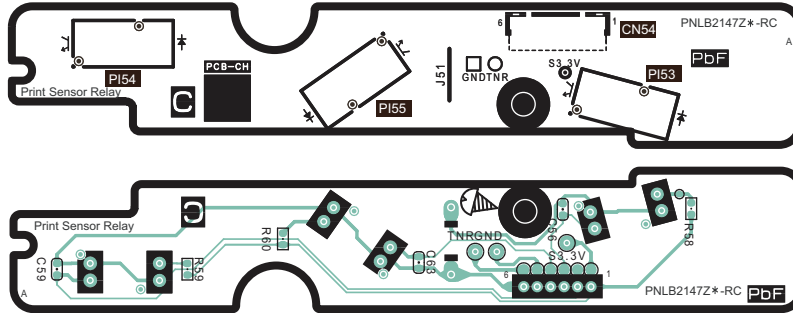

KX-MB2230EU / KX-MB2270EU / KX-MB2515EU / KX-MB2545EU / KX-MB2575EU / DP-MB310EU
PRINT SENSOR RELAY BOARD

17.2.4. TONER SENSOR Board

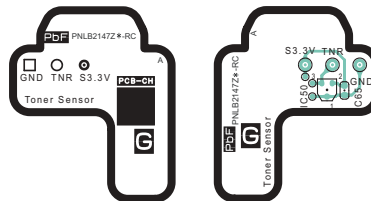

KX-MB2230EU / KX-MB2270EU / KX-MB2515EU / KX-MB2545EU / KX-MB2575EU / DP-MB310EU
TONER SENSOR BOARD

17.2.5. INTERLOCK SWITCH Board

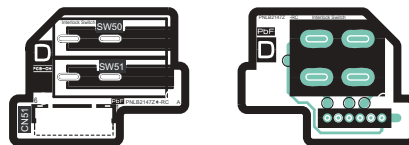

KX-MB2230EU / KX-MB2270EU / KX-MB2515EU / KX-MB2545EU / KX-MB2575EU / DP-MB310EU
INTERLOCK SWITCH BOARD

17.2.6. CENTER RELAY Board

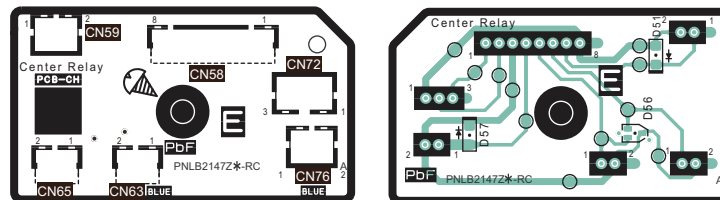

KX-MB2230EU / KX-MB2270EU / KX-MB2515EU / KX-MB2545EU / KX-MB2575EU / DP-MB310EU
CENTER RELAY BOARD

17.2.7. REAR SENSOR Board

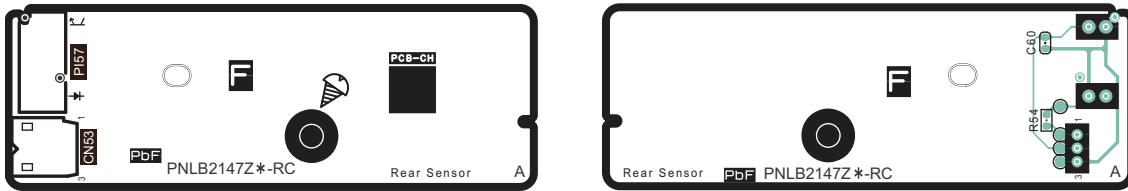

KX-MB2230EU / KX-MB2270EU / KX-MB2515EU / KX-MB2545EU / KX-MB2575EU / DP-MB310EU
REAR SENSOR BOARD

17.2.8. FUSER Board

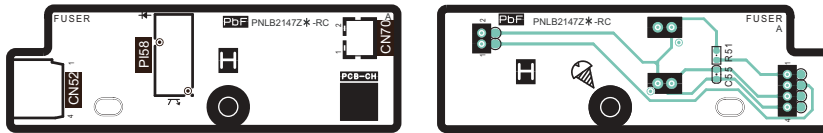

KX-MB2230EU / KX-MB2270EU / KX-MB2515EU / KX-MB2545EU / KX-MB2575EU / DP-MB310EU
FUSER BOARD

17.2.9. VARISTOR Board

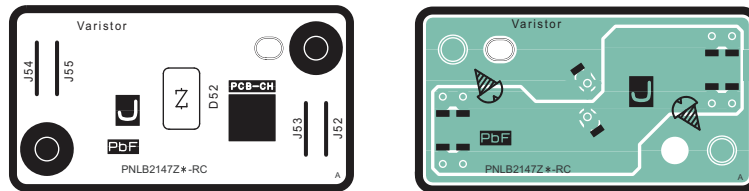

KX-MB2230EU / KX-MB2270EU / KX-MB2515EU / KX-MB2545EU / KX-MB2575EU / DP-MB310EU
VARISTOR BOARD

17.2.10. OPC CONTACT Board

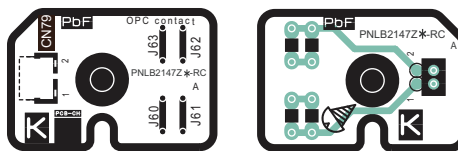

KX-MB2230EU / KX-MB2270EU / KX-MB2515EU / KX-MB2545EU / KX-MB2575EU / DP-MB310EU
OPC CONTACT BOARD

17.2.11. TONER CONTACT Board

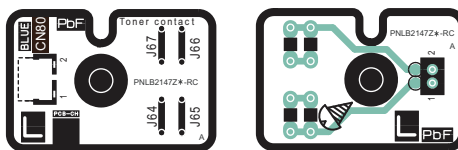

KX-MB2230EU / KX-MB2270EU / KX-MB2515EU / KX-MB2545EU / KX-MB2575EU / DP-MB310EU
TONER CONTACT BOARD

17.2.12. DOCU SENSOR Board



KX-MB2230EU / KX-MB2270EU / KX-MB2515EU / KX-MB2545EU / KX-MB2575EU / DP-MB310EU
DOCU SENSOR BOARD

17.2.13. RPS Board

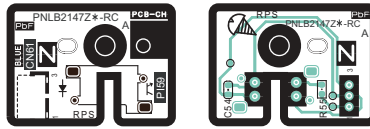

KX-MB2230EU / KX-MB2270EU / KX-MB2515EU / KX-MB2545EU / KX-MB2575EU / DP-MB310EU
RPS BOARD

17.2.14. ADF RELAY Board

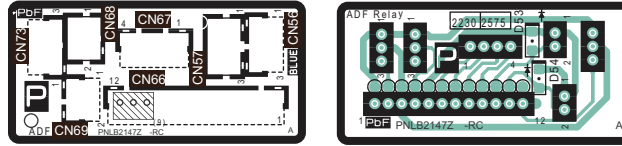

KX-MB2230EU / KX-MB2270EU / KX-MB2515EU / KX-MB2545EU / KX-MB2575EU / DP-MB310EU
ADF RELAY BOARD

17.2.15. POWER SWITCH Board

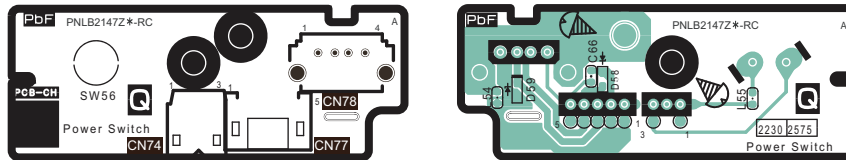

KX-MB2230EU / KX-MB2270EU / KX-MB2515EU / KX-MB2545EU / KX-MB2575EU / DP-MB310EU
POWER SWITCH BOARD

17.2.16. RADF Board

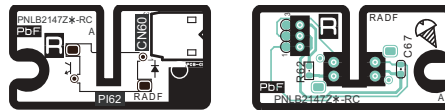

KX-MB2515EU / KX-MB2545EU / KX-MB2575EU / DP-MB310EU
RADF BOARD

17.2.17. MPT RELAY Board

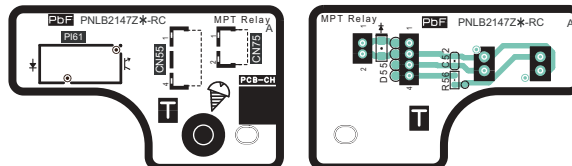

KX-MB2515EU / KX-MB2545EU / KX-MB2575EU / DP-MB310EU
MPT RELAY BOARD

17.2.18. WLAN ANT_V Board

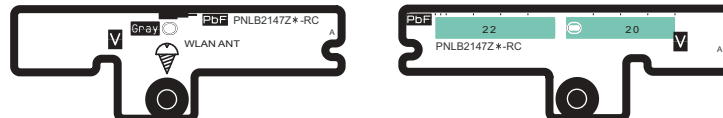

KX-MB2270EU / KX-MB2575EU
WLAN ANT BOARD

17.2.19. WLAN ANT_W Board



KX-MB2270EU / KX-MB2575EU
WLAN ANT BOARD

17.2.20. ONE TOUCH KEY Board

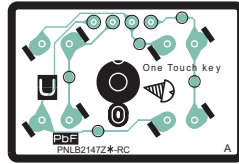
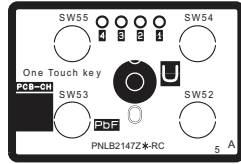

DP-MB310EU
ONE TOUCH KEY BOARD

17.3. Back Light Board

17.3.1. Back Light Board

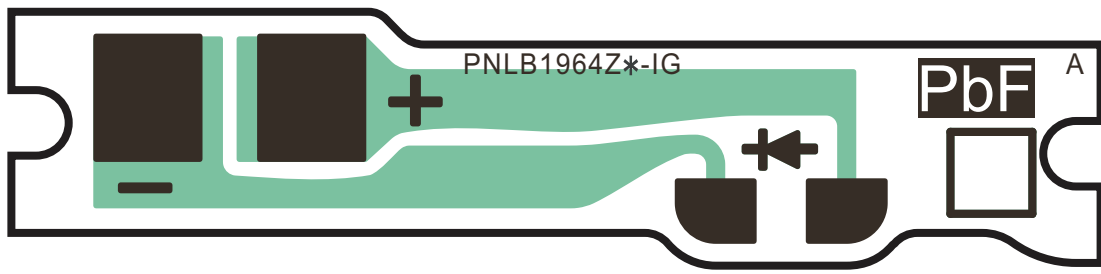

KX-MB2515EU / KX-MB2545EU / KX-MB2575EU / DP-MB310EU
Back Light BOARD

17.4. High Voltage Power Supply Board

17.4.1. High Voltage Power Supply Board: Component View

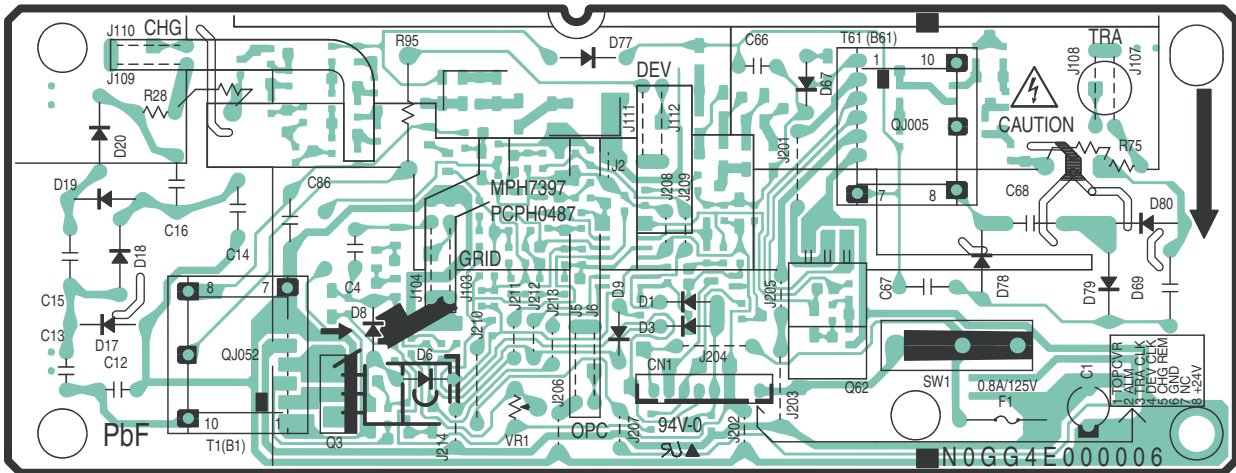

KX-MB2230EU / KX-MB2270EU / KX-MB2515EU / KX-MB2545EU / KX-MB2575EU / DP-MB310EU
HIGH VOLTAGE POWER SUPPLY BOARD (COMPONENT VIEW)

17.4.2. High Voltage Power Supply Board: Bottom View

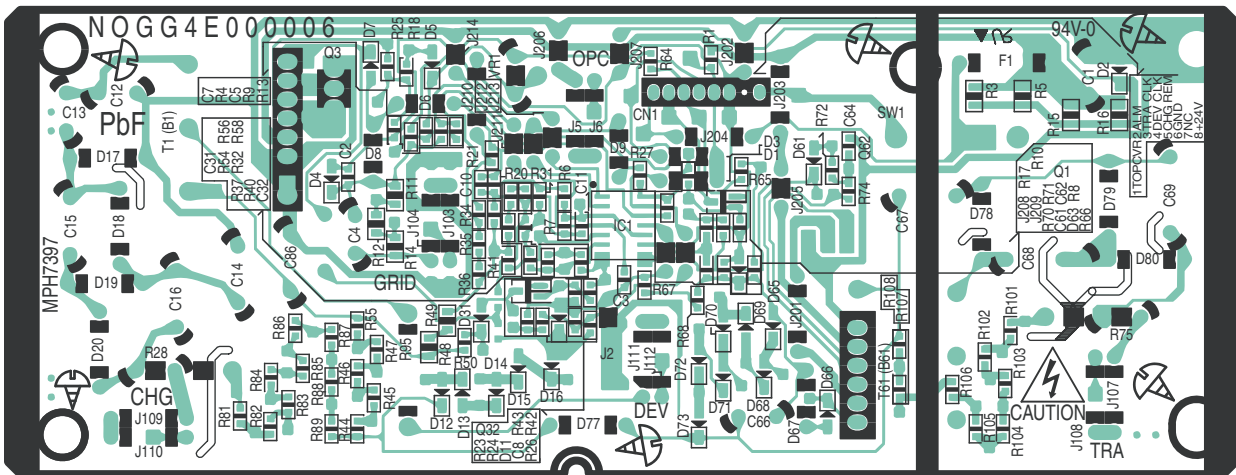

KX-MB2230EU / KX-MB2270EU / KX-MB2515EU / KX-MB2545EU / KX-MB2575EU / DP-MB310EU
HIGH VOLTAGE POWER SUPPLY BOARD (BOTTOM VIEW)

17.5. Low Voltage Power Supply Board

17.5.1. Low Voltage Power Supply Board: Component View

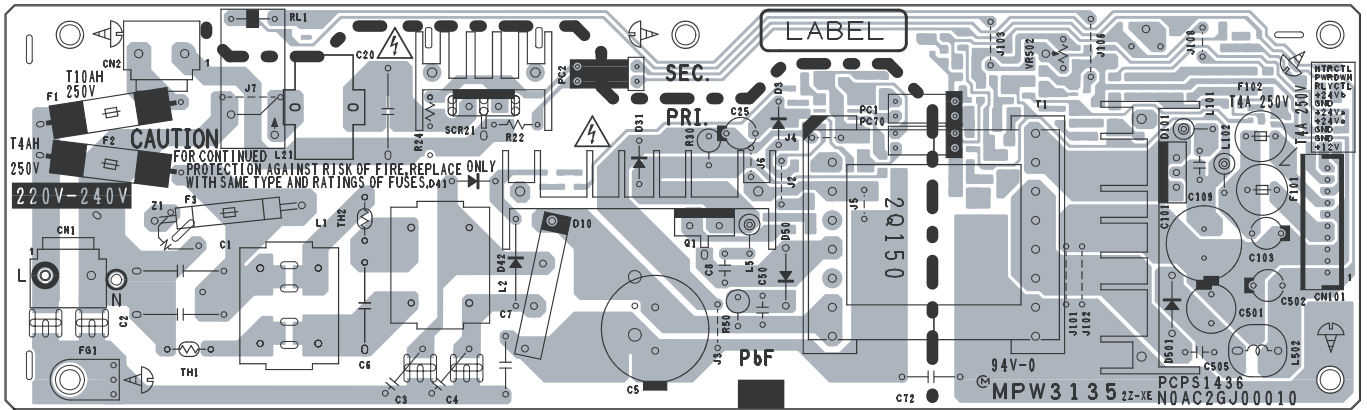

KX-MB2230EU / KX-MB2270EU / KX-MB2515EU / KX-MB2545EU / KX-MB2575EU / DP-MB310EU
LOW VOLTAGE POWER SUPPLY BOARD (COMPONENT VIEW)

17.5.2. Low Voltage Power Supply Board: Bottom View

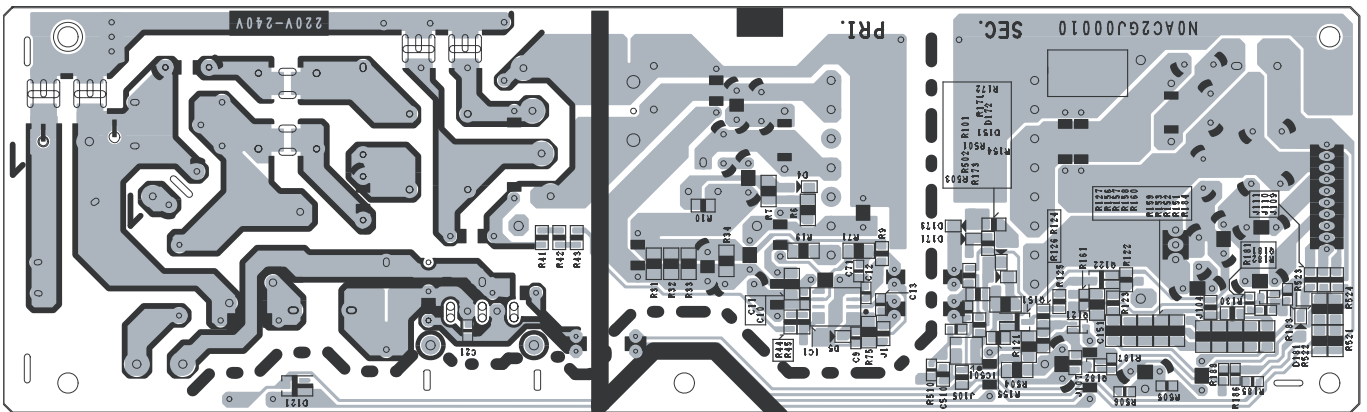

KX-MB2230EU / KX-MB2270EU / KX-MB2515EU / KX-MB2545EU / KX-MB2575EU / DP-MB310EU
LOW VOLTAGE POWER SUPPLY BOARD (BOTTOM VIEW)

Memo

18 Exploded View and Replacement Parts List

18.1. Cabinet, Mechanical and Electrical Parts Location

18.1.1. General Section

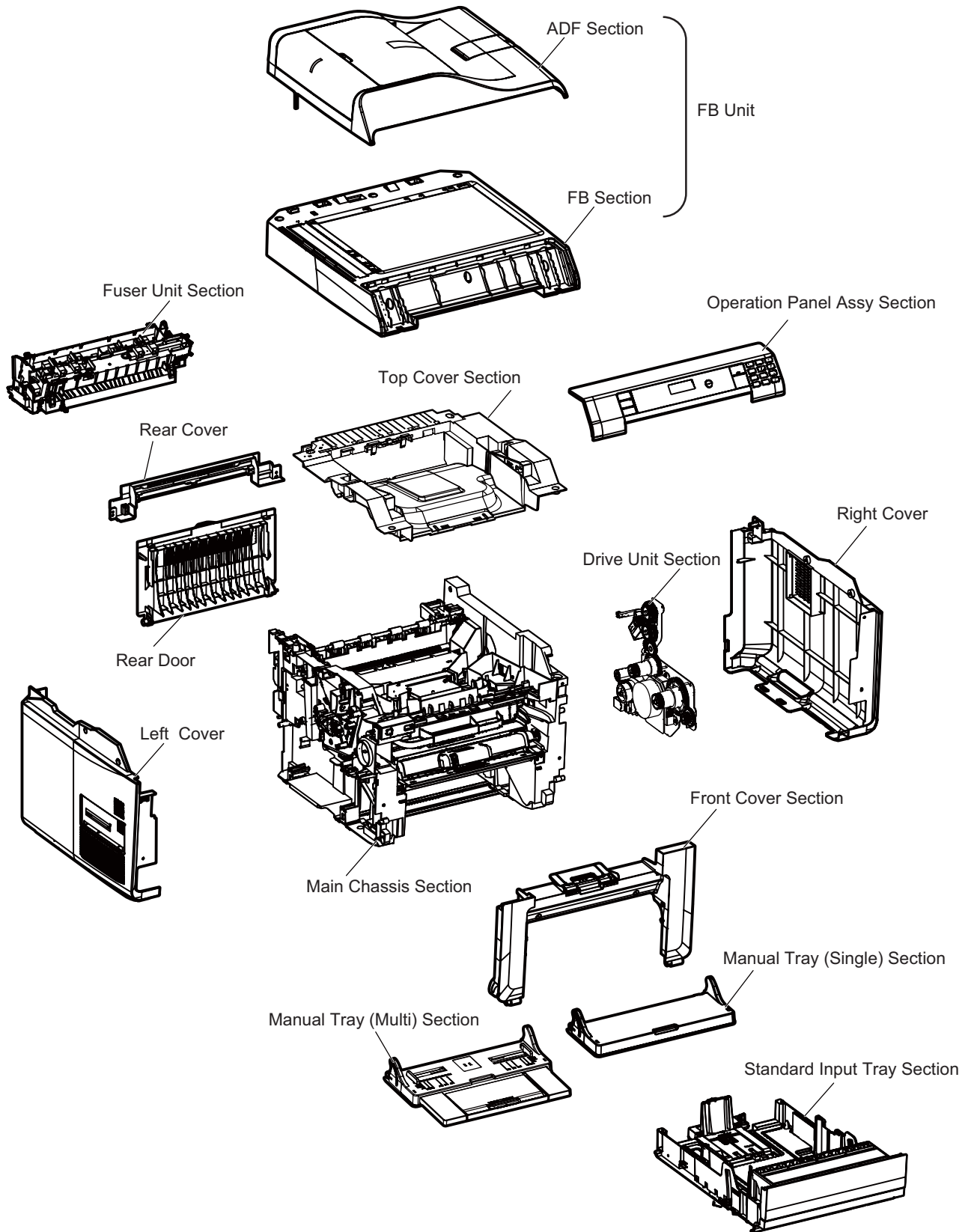

18.1.2. Operation Panel Section

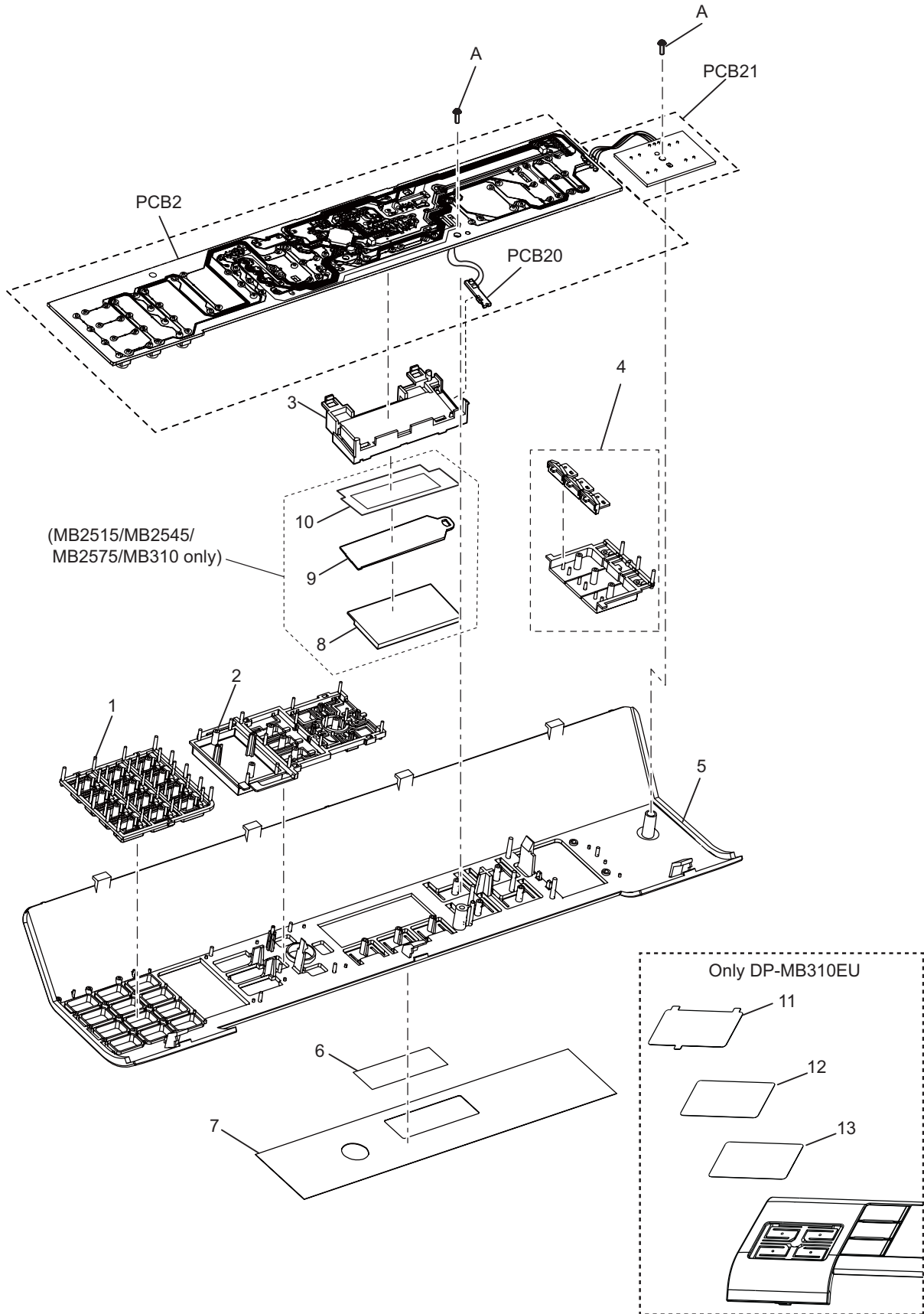

Safety	Ref. No.	Part No.	Part Name & Description	Remarks
	1	PNBX1346Z1	PUSH BUTTON, 12 KEY (MB2230/2270/2515/2545/2575EU only)	ABS-HB
	1	PNBX1346Z2	PUSH BUTTON, 12 KEY (MB310JT only)	ABS-HB
	2	PNBX1347Z1	PUSH BUTTON, NAVI KEY (MB2230/2270EU only)	ABS-HB
	2	PNBX1347K2	PUSH BUTTON, NAVI KEY (MB2515EU only)	ABS-HB
	2	PNBX1347Z2	PUSH BUTTON, NAVI KEY (MB2545/2575EU only)	ABS-HB
	2	PNBX1347Z3	PUSH BUTTON, NAVI KEY (MB310EU only)	ABS-HB
	3	PNHR1799Z	GUIDE (MB2230/2270EU only)	PS-HB
	3	PNHR1800Y	GUIDE (MB2515/2545/2575/310EU only)	ABS-HB
	4	PNYBMB2230JT	MODE KEY ASSY (MB2230/2270EU only)	
	4	PNYBMB2515JT	MODE KEY ASSY (MB2515EU only)	
	4	PNYBMB2575JT	MODE KEY ASSY (MB2545/2575EU only)	
	4	PNYBMB310JT	MODE KEY ASSY (MB310EU only)	
	5	PNGG1339Z1	CABINET COVER (MB2230EU only)	PS-HB
	5	PNGG1344Z1	CABINET COVER (MB2270EU only)	PS-HB
	5	PNGG1346J1	CABINET COVER (MB2515EU only)	PS-HB
	5	PNGG1345Z1	CABINET COVER (MB2545EU only)	PS-HB
	5	PNGG1341Z1	CABINET COVER (MB2575EU only)	PS-HB
	5	PNGG1340J2	CABINET COVER (MB310EU only)	PS-HB
	6	PNGP1288Z	LCD COVER	PC
	7	PNGP1287Z1	PANEL (MB2230EU only)	PET-HX
	7	PNGP1297Z1	PANEL (MB2270EU only)	PET-HX
	7	PNGP1300Z1	PANEL (MB2515EU only)	PET-HX
	7	PNGP1298Z1	PANEL (MB2545EU only)	PET-HX
	7	PNGP1296Z1	PANEL (MB2575EU only)	PET-HX
	7	PNGP1301Z1	PANEL (MB310EU only)	PET-HX
	8	L5DYBY00054	LIQUID CRYSTAL DISPLAY (MB2515/2545/2575/310EU only)	
	9	PNHR1811Z	GUIDE (MB2515/2545/2575/310EU only)	PMMA
	10	PNHX1695Z	LCD COVER SHEET (MB2515/2545/2575/310EU only)	PET
	11	PNGV1018Y	CARD COVER (MB310EU only)	PET
	12	PNGD1067Z	CARD (MB310EU only)	
	13	PNHX1650Z	CARD SHEET (MB310EU only)	PET

18.1.3. ADF Section (1)

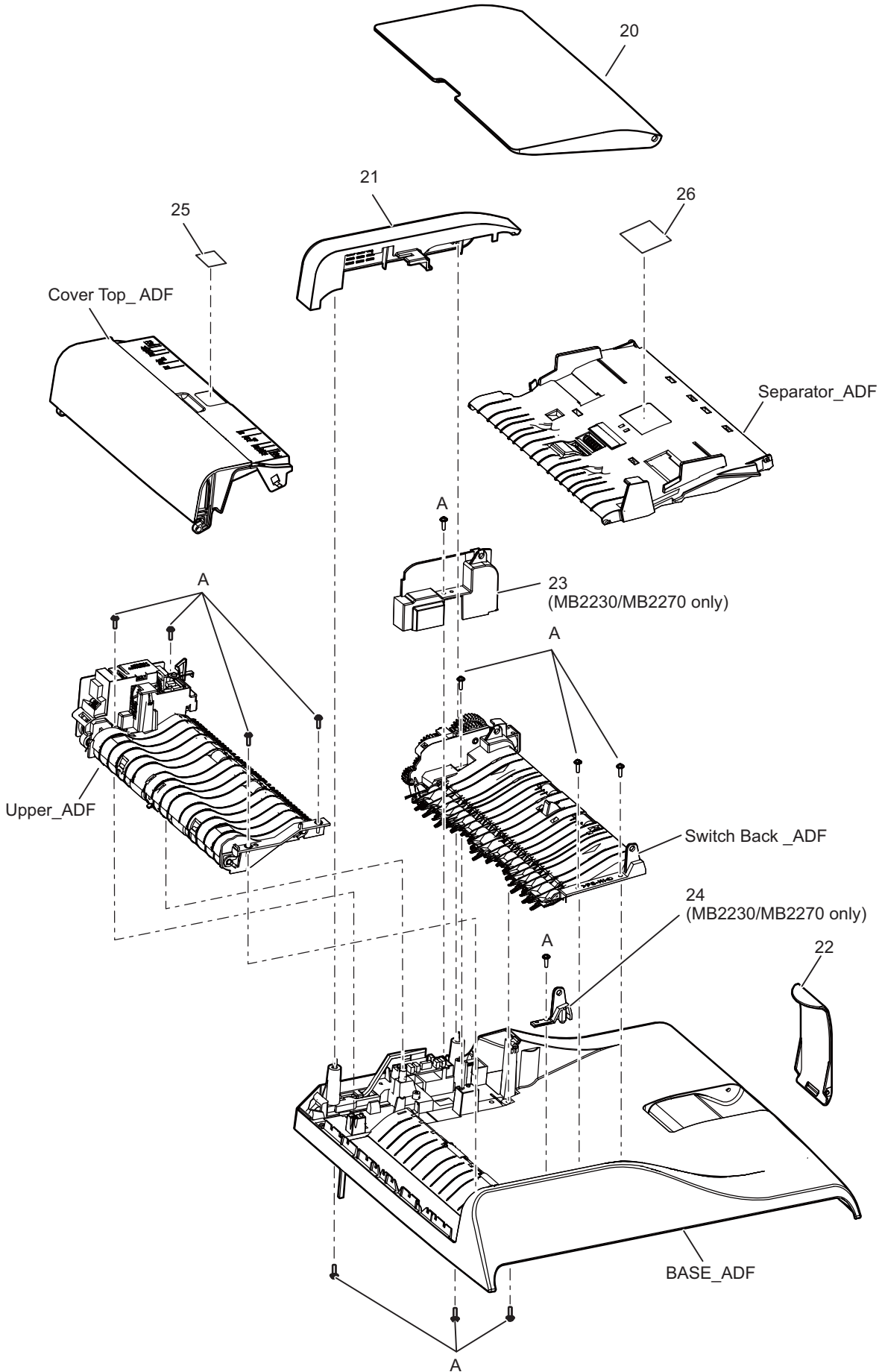

Safety	Ref. No.	Part No.	Part Name & Description	Remarks
	20	PNKS1032Z1	TRAY	PS-HB
	21	PNKV1211Z1	COVER	PS-HB
	22	PNKS1034Z1	TRAY	PS-HB
	23	PNKE1280Z1	COVER (MB2230/2270EU only)	PS-HB
	24	PNKE1281Z1	COVER (MB2230/2270EU only)	PS-HB
	25	PNQT2662Z	LABEL, LIFT TO OPEN	
	26	PNQT2695Z	INDICATION PLATE-LABEL	

18.1.4. ADF Section (2)

Cover-Top ADF

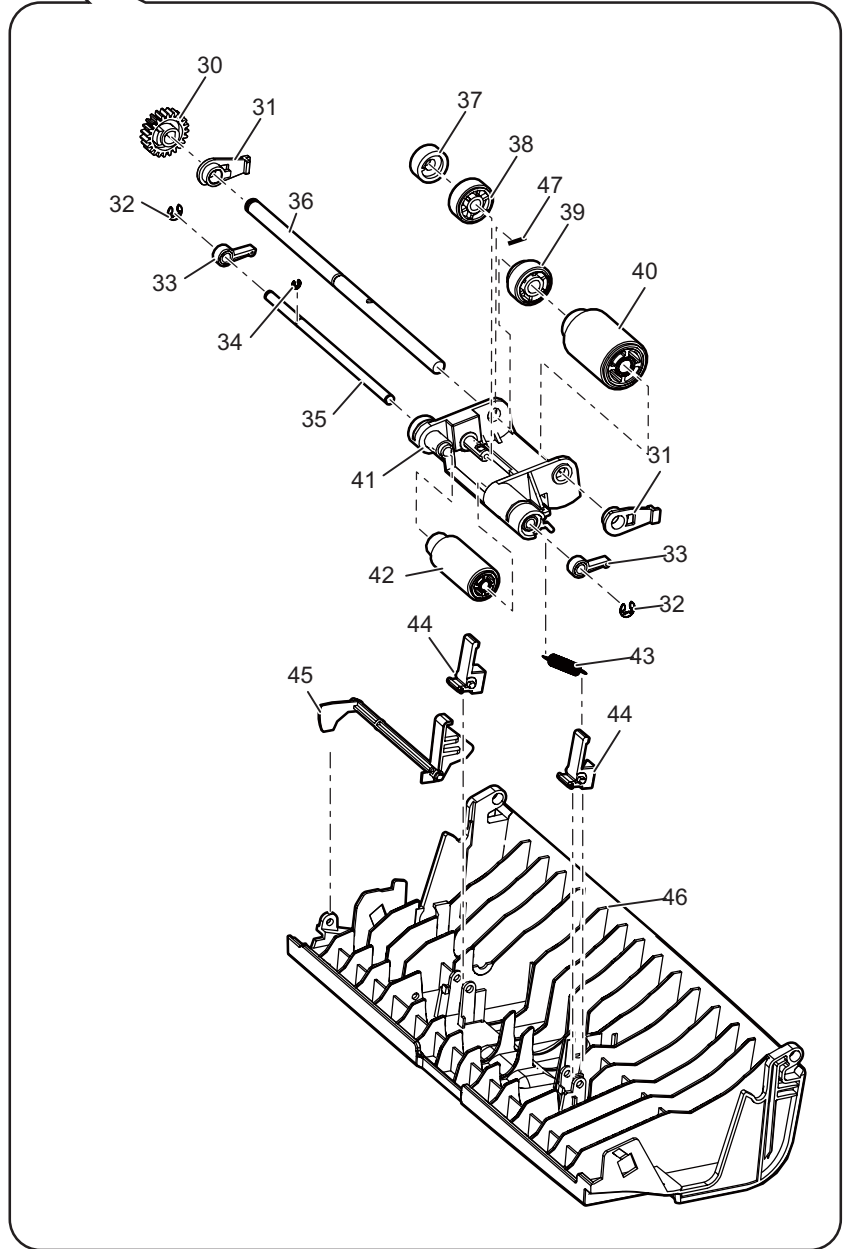
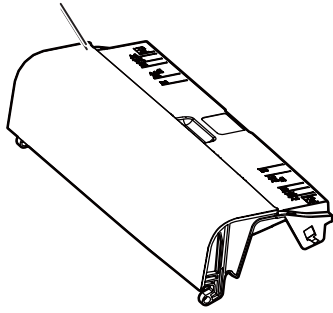

Safety	Ref. No.	Part No.	Part Name & Description	Remarks
	30	PNDG1032Y	GEAR	
	31	PFDJ1044Z	SPACER	
	32	XUC2FJ	RETAINING RING	
	33	PFDE1244Z	LEVER	
	34	XUC3FJP	RETAINING RING	
	35	PNDF1034Z	SHAFT	
	36	PNDF1102Z	SHAFT	SUM23
	37	PFDG1416Z	GEAR	
	38	PFDG1417Z	GEAR	
	39	PFDG1413Y	GEAR	
	40	PFDR1065Y	ROLLER	
	41	PFHR1479Z	GUIDE	
	42	PNDR1023Y	ROLLER	
	43	PNUS1064Z	COIL SPRING	
	44	PFDE1247X	LEVER	
	45	PNDE1056Z	LEVER	ABS-HB
	46	PNKV1210Y1	COVER	PS-HB
	47	PFDF1095Y	SHAFT	

18.1.5. ADF_Separator Section 1

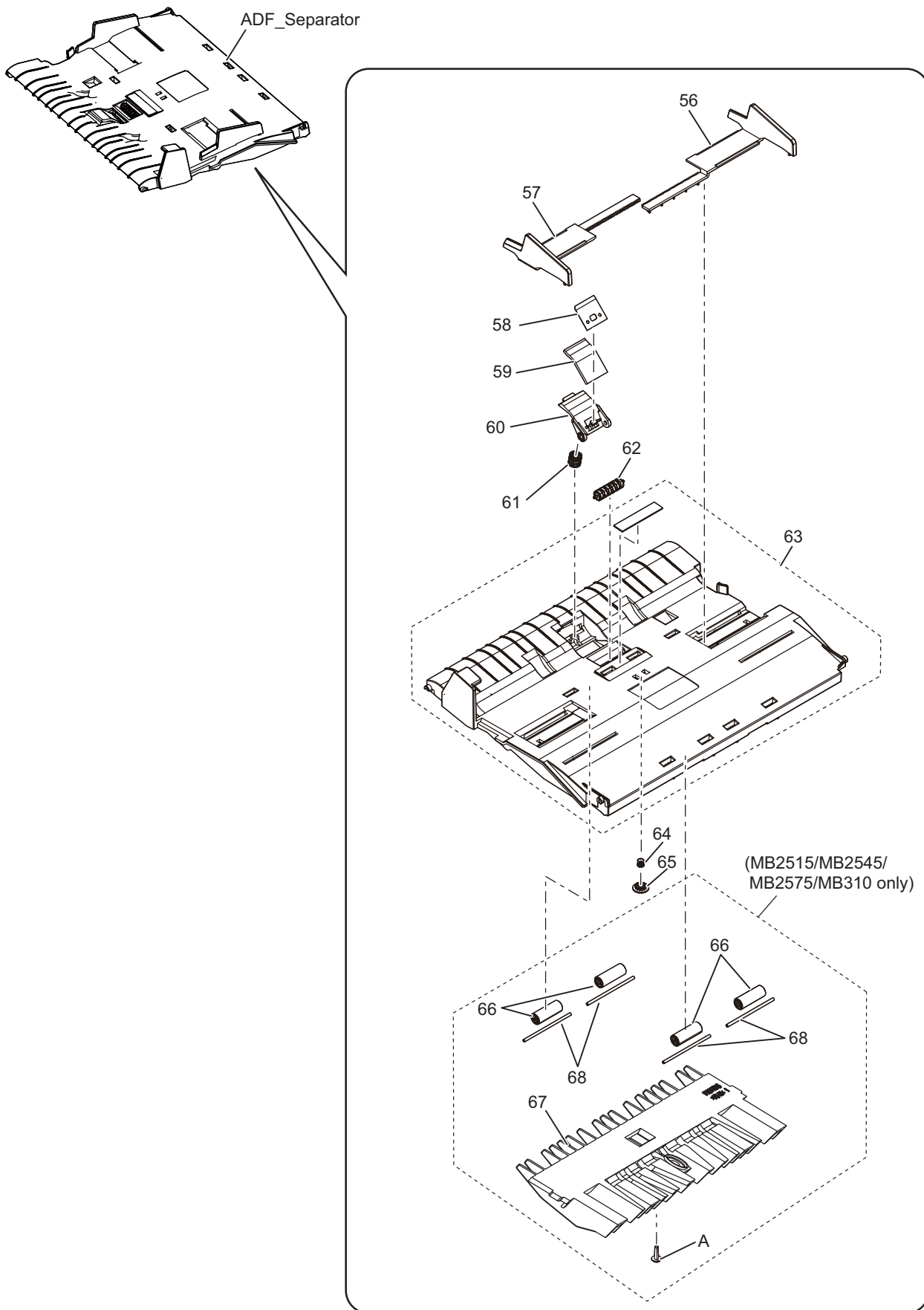

Safety	Ref. No.	Part No.	Part Name & Description	Remarks
	56	PFKR1110Z1	GUIDE	
	57	PFKR1111Z1	GUIDE	
	58	PFHX1849Z	PLASTIC PARTS	
	59	PNHG1223Z	RUBBER PARTS	
	60	PFHR1478X	GUIDE	
	61	PNUS1230Y	COIL SPRING	SUS304EPB
	62	PFDR1062Z	ROLLER	
	63	PNYC1B2230JT	ADF SEPARATION FRAME KIT	
	64	PFUS1222Z	COIL SPRING	
	65	PFDG1015Y	GEAR	
	66	PFDR1073Z	ROLLER (MB2515/2545/2575/310EU only)	POM-HB
	67	PNUV1046Z	CASE/COVER (MB2515/2545/2575/310EU only)	PS-HB
	68	PFUS1568Z	BAR SPRING (MB2515/2545/2575/310EU only)	

18.1.6. ADF_Upper Section

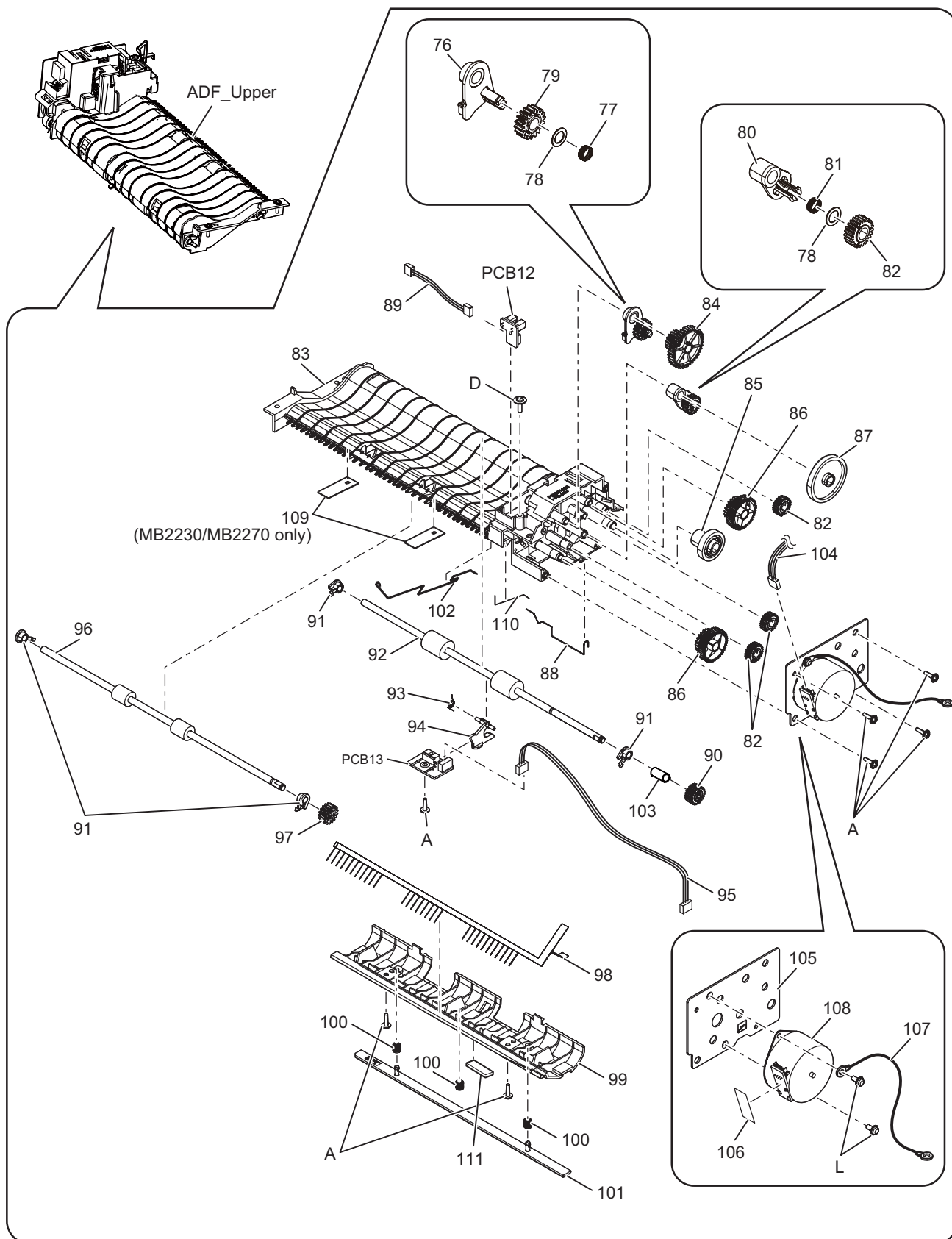

Safety	Ref. No.	Part No.	Part Name & Description	Remarks
	76	PNDE1055Z	LEVER	ABS-HB
	77	PNUS1228Z	COIL SPRING	SUS304EPB
	78	PFNPD062095	SPACER	
	79	PNDG1038Z	GEAR	
	80	PNDE1054Z	LEVER	ABS-HB
	81	PNUS1261Z	COIL SPRING	SUS304EPB
	82	PNDG1005Y	GEAR	
	83	PNUE1038X	KEYLOCK	PS-HB
	84	PNDG1124Z	GEAR	POM-M90
	85	PFDG1555Z	GEAR	
	86	PNDG1123Z	GEAR	POM-M90
	87	PFDG1552Z	GEAR	
	88	PNUS1231Y	BAR SPRING	SUS304EPB
	89	PNJS031094Z	CONNECTOR	
	90	PNDG1145Z	GEAR	POM-M90
	91	PFDJ1116Z	SPACER	
	92	PNDR1060Z	ROLLER	SUM23+EPD M
	93	PFUS1629Z	TORSION SPRING	
	94	PNDE1058Z	LEVER	ABS-HB
	95	PNJS031093Z	CONNECTOR	
	96	PNDR1005Z	ROLLER	
	97	PNDG1031Z	GEAR	
	98	PNJV1015Z	BRUSH	
	99	PNUE1039Z	KEYLOCK	PS-HB
	100	PFUS1344Z	COIL SPRING	
	101	PFUE1050Z	FRAME	
	102	PNUS1232Y	BAR SPRING	SUS304EPB
	103	PFUS1812Z	COIL SPRING	
	104	PNJS041050Z	CONNECTOR	
	105	PNMH1269Z	METAL PARTS	SECC
	106	PFHX2126Z	PLASTIC PARTS	
	107	PNVW1043Z	CONNECTOR	
	108	L6HAYYYK0053	DC MOTOR	
	109	PNHX1554Y	PLASTIC PARTS (MB2230/2270EU only)	PET/VTM-2
	110	PNUS1229Z	BAR SPRING	SUS304EPB
	111	PNHS1478Z	FELT PARTS	Werthen- SM

18.1.7. Top Cover

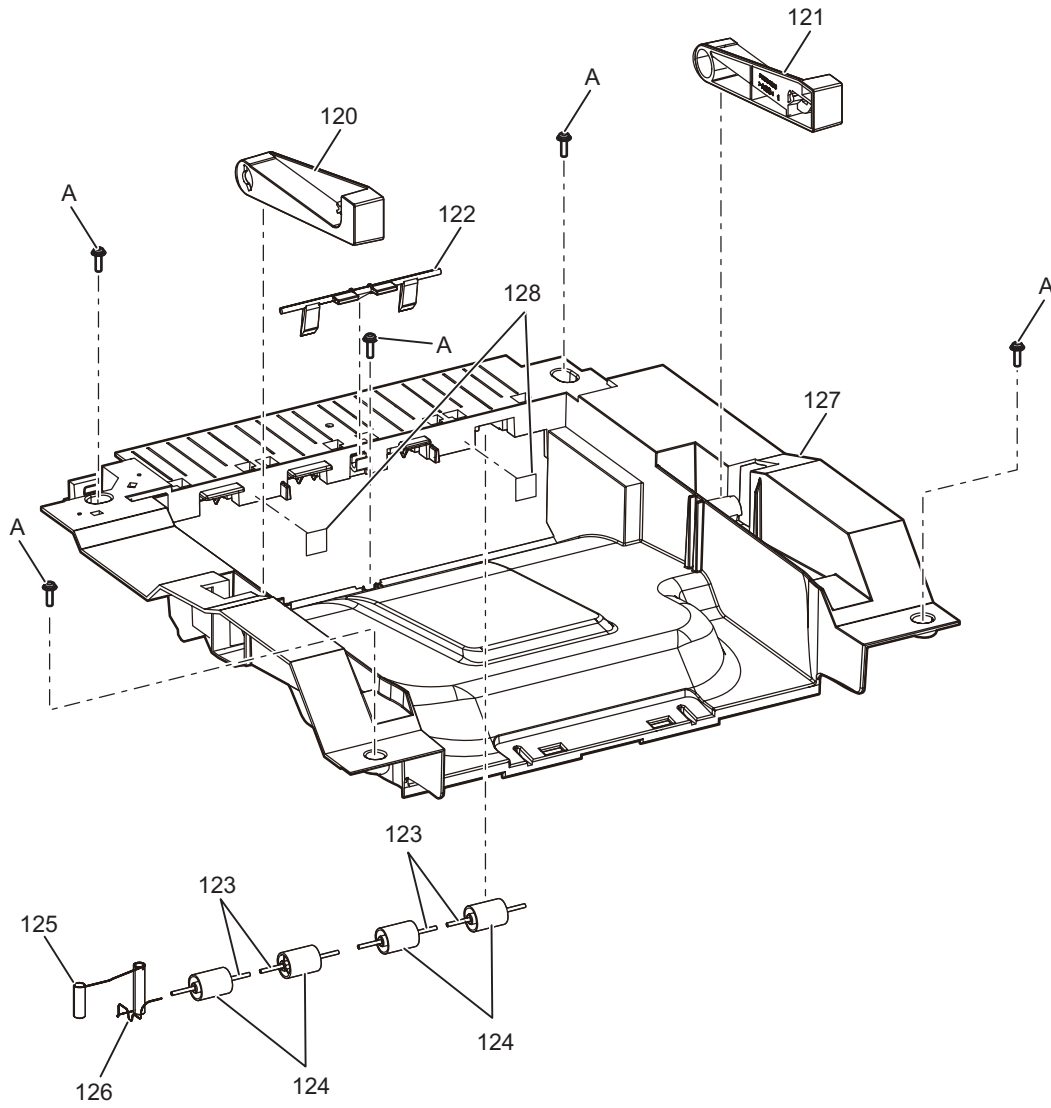

Safety	Ref. No.	Part No.	Part Name & Description	Remarks
	120	PNDE1062Z	LEVER	ABS-HB
	121	PNDE1063Z	LEVER	ABS-HB
	122	PNDE1051Z	LEVER	POM-M90
	123	PFUS1568Z	BAR SPRING	
	124	PFDR1069Z	ROLLER	
	125	PNUS1223Z	COIL SPRING	SUS304-WPS
	126	PNUS1279Z	COIL SPRING	SUS304-WPS
	127	PNKV1204Y1	COVER (MB2230/2270/2515/2545/2575EU only)	PS-HB
	127	PNKV1204Y2	COVER (MB310EU only)	PS-HB
	128	PNQT1229Z	INDICATION PLATE-LABEL	

18.1.8. Switch_back Section

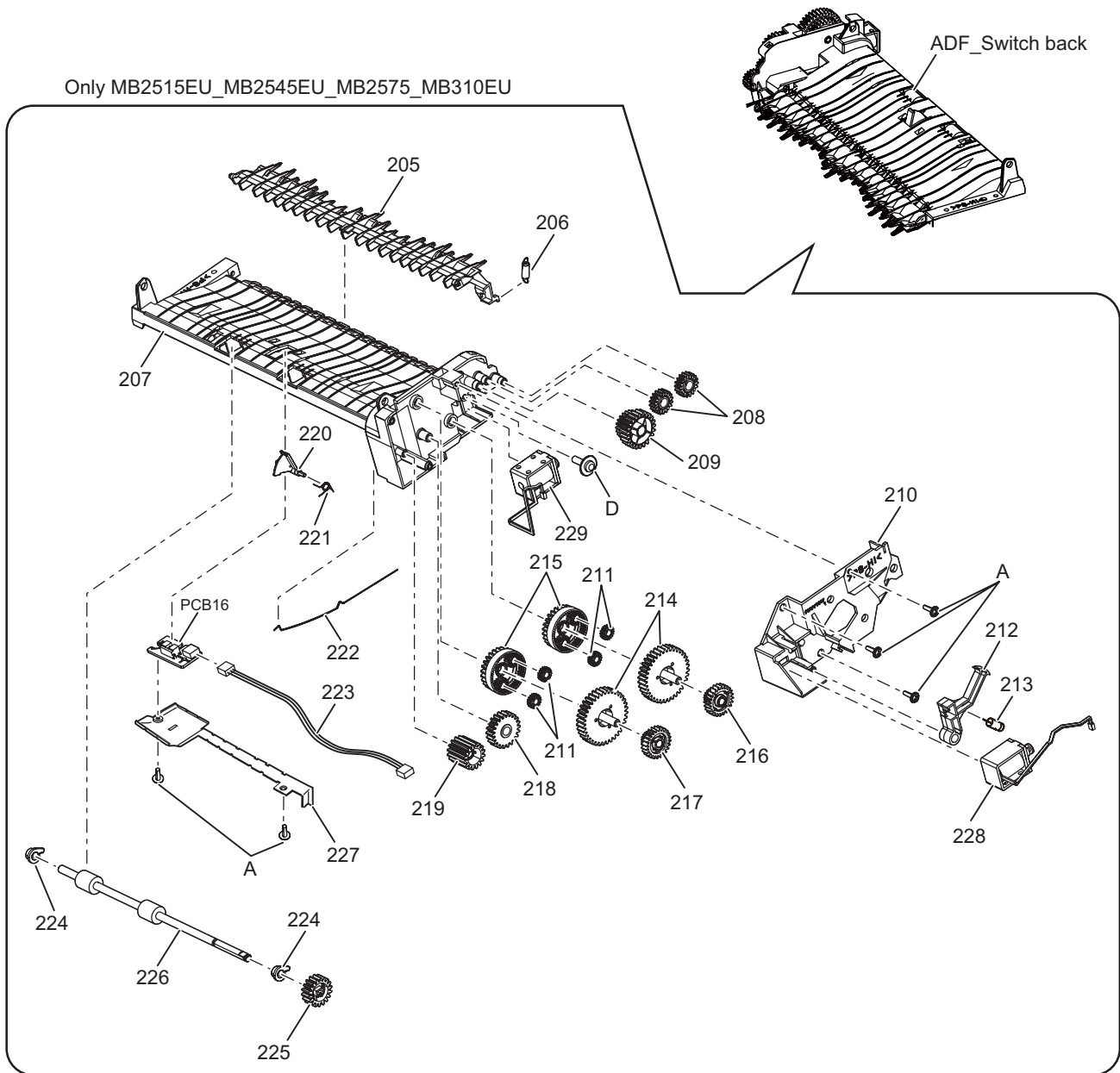

Safety	Ref. No.	Part No.	Part Name & Description	Remarks
	205	PNUG1025Z	GUIDE (MB2515/2545/2575/310EU only)	PS-HB
	206	PNUS1268Z	COIL SPRING (MB2515/2545/2575/310EU only)	SUS304WPB
	207	PNKE1279Z1	COVER (MB2515/2545/2575/310EU only)	PS-HB
	208	PNDG1038Z	GEAR (MB2515/2545/2575/310EU only)	
	209	PNDG1125Z	GEAR (MB2515/2545/2575/310EU only)	POM-M90
	210	PNUV1047Z	CASE/COVER (MB2515/2545/2575/310EU only)	PS-HB
	211	PFDG1606Z	GEAR (MB2515/2545/2575/310EU only)	POM-M90
	212	PNDE1057Z	LEVER (MB2515/2545/2575/310EU only)	
	213	PFUS1896Z	COIL SPRING (KX-MB2515/KX-MB2545/KX-MB2575 only)	
	214	PJDGB0168Z	GEAR (MB2515/2545/2575/310EU only)	
	215	PFDG1605Z	GEAR (MB2515/2545/2575/310EU only)	
	216	PJDGB0166Z	GEAR (MB2515/2545/2575/310EU only)	
	217	PJDGB0167Z	GEAR (MB2515/2545/2575/310EU only)	
	218	PFDG1622Z	GEAR (MB2515/2545/2575/310EU only)	
	219	PNDG1027Z	GEAR (MB2515/2545/2575/310EU only)	
	220	PFDE1308Y	LEVER (MB2515/2545/2575/310EU only)	
	221	PFUS1629Z	TORSION SPRING (MB2515/2545/2575/310EU only)	
	222	PNUS1234Y	COIL SPRING (MB2515/2545/2575/310EU only)	SUS304EPB
	223	PNJS031092Z	CONNECTOR (MB2515/2545/2575/310EU only)	
	224	PFDJ1116Z	SPACER (MB2515/2545/2575/310EU only)	POM-HB
	225	PNDG1126Z	GEAR (MB2515/2545/2575/310EU only)	POM-M90
	226	PFDR1104Y	ROLLER (MB2515/2545/2575/310EU only)	
	227	PNUV1059Z	CASE/COVER (MB2515/2545/2575/310EU only)	PS-HI-HB
	228	L9AAAYB0024	ERECTROMAGNETIC COIL (MB2515/2545/2575/310EU only)	
	229	L9AAAYB0001	ERECTROMAGNETIC COIL (MB2515/2545/2575/310EU only)	

18.1.9. ADF_BASE Section

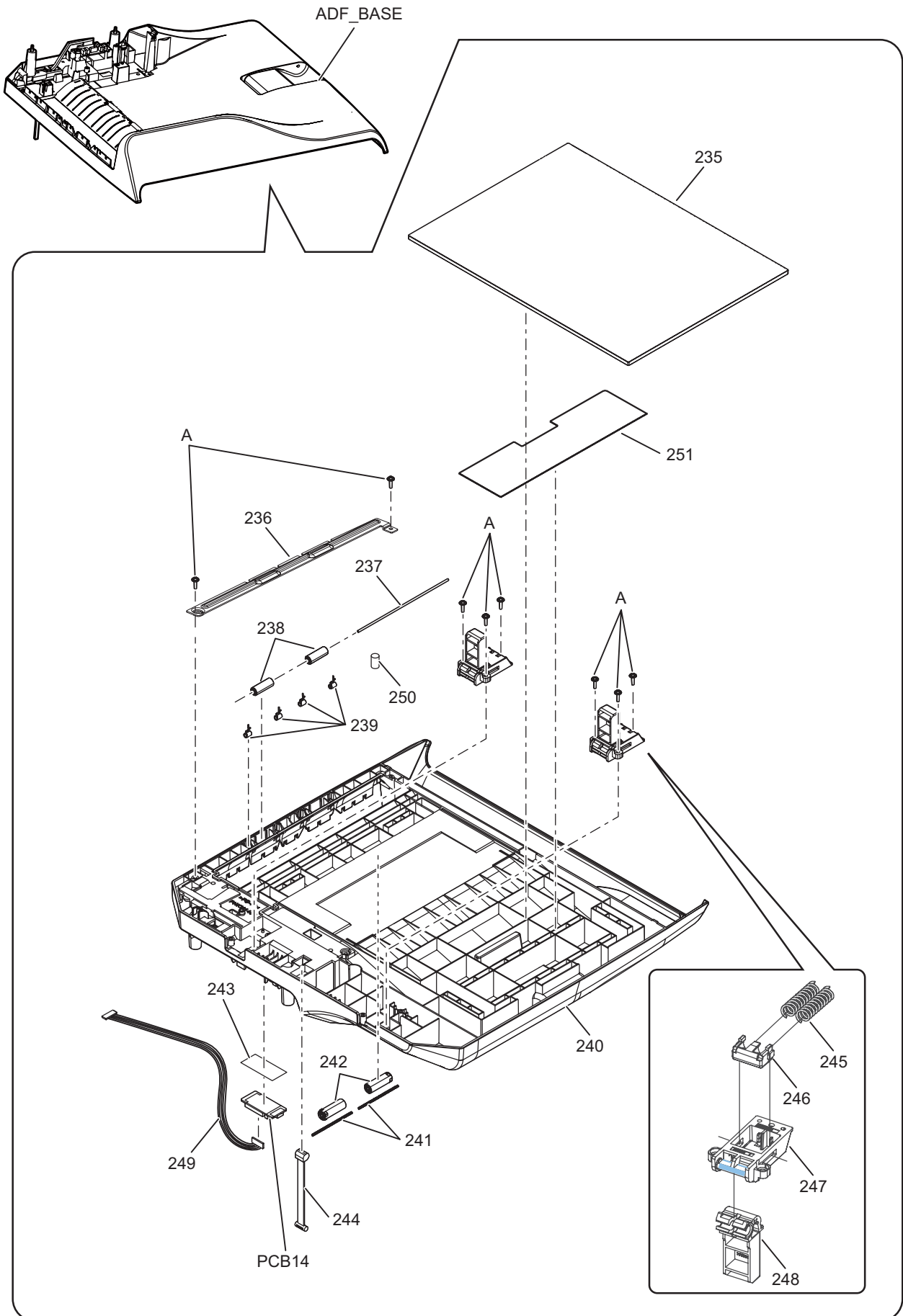

Safety	Ref. No.	Part No.	Part Name & Description	Remarks
	235	PNHX1359Z	PLASTIC PARTS	PET/VTM-2
	236	PNMH1270Z	METAL PARTS	SECC
	237	PNDF1066Z	SHAFT	
	238	PFDR1073Z	ROLLER	POM-HB
	239	PNUS1233Z	COIL SPRING	SUS304EPB
	240	PNKM1488X1	CABINET BODY	PS-HB
	241	PFUS1621Z	BAR SPRING	
	242	PFDR1066Z	ROLLER	
	243	PFHX2126Z	PLASTIC PARTS (MB2230/MB2270EU only)	
	243	PNHX1680Z	PLASTIC PARTS (MB2515/2545/2575/310EU only)	DS-45VP
	244	PNHR1070Z	HINGE-STAY	
	245	PFUS1350Z	COIL SPRING	
	246	PFHR1806Z	CASE/COVER	
	247	PFHR1804Z	CASE/COVER	
	248	PFHR1805V	HINGE-STAY	
	249	PNJS091023Z	CONNECTOR (MB2230/2270EU only)	
	249	PNJS121018Z	CONNECTOR (MB2515/2545/2575/310EU only)	
	250	PFUS1696Z	COIL SPRING	
	251	PNHX1539Z	PLASTIC PARTS	

18.1.10. FB Unit Section

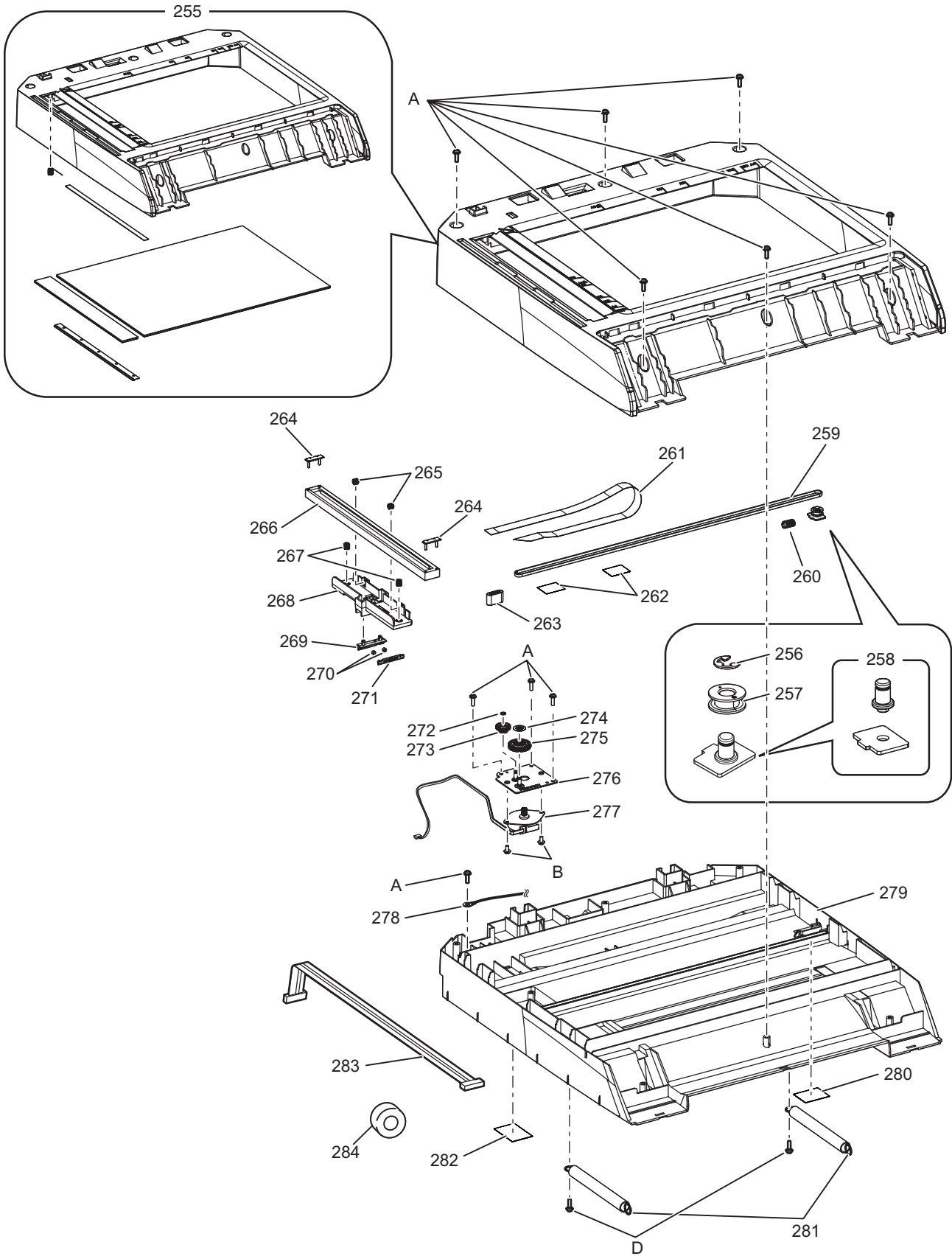

Safety	Ref. No.	Part No.	Part Name & Description	Remarks
	255	PNZXMB2230JT	SCANNER GLASS ASS'Y	
	256	XUC4FJP	RETAINING RING	
	257	PNDE1028Z	LEVER	POM-HB
	258	PNZF3B2230JT	PULLEY SHUFT ASS'Y	
	259	PNDV1005Z	ANGULAR BELT	
	260	PNUS1216Z	COIL SPRING	SUS304WPB
	261	PNJE1075Z	LEAD WIRE, FFC	
	262	PFHE1319Z	PLASTIC PARTS	
	263	PFLB1K002	INSULATOR, CORE	
	264	PNDE1065Z	SPACER	PE
	265	PFUS1344Z	COIL SPRING	
	266	N2GAYY000004	IMAGE SENSOR	
	267	PFUS1642Y	COIL SPRING	
	268	PNDC1002Y	MECHANISM CASE	ABS-HB
	269	PNDE1034Z	LEVER	
	270	PNUS1155Z	COIL SPRING	
	271	PNDE1035Z	LEVER	
	272	PFNPD031054C	WASHER	
	273	PNDG1056Y	GEAR	
	274	PNDE1030Z	LEVER	
	275	PNDG1057Y	GEAR	
	276	PNZF3B1500RU	FB MOTOR SHUFT ASS'Y	
	277	L6HAYYYK0052	DC MOTOR	
	278	PNVW1038Z	CONNECTOR	
	279	PNKM1486Y1	CABINET BODY (MB2230/2270/2515/2545/2575EU only)	PS-HB
	279	PNKM1486Y2	CABINET BODY (MB310EU only)	PS-HB
	280	PNHX1636Z	PLASTIC PARTS	PET
	281	PNUS1218Z	TORSION SPRING	SUS304WPB
	282	PNHX1637Z	PLASTIC PARTS	PET
	283	PNJS081096Z	CONNECTOR	
	284	J0KE00000115	INSULATOR	

18.1.11. Rear side and Fuser Unit Section

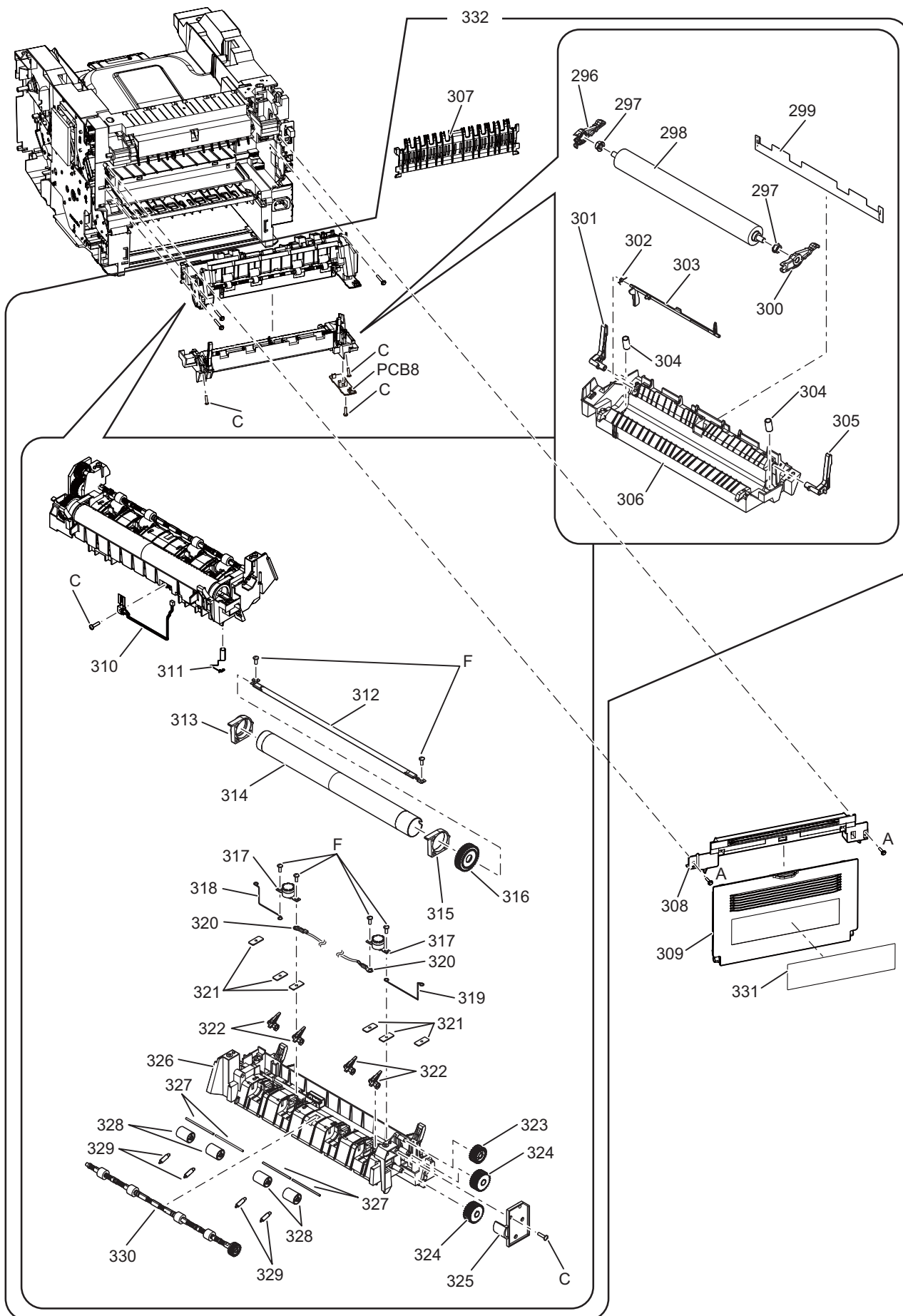

Safety	Ref. No.	Part No.	Part Name & Description	Remarks
	296	PNHR1785Z	GUIDE	PBTRG301A B
	297	PNDJ1021Z	SPACER	
	298	PNDS1038Z	ROLLER	
	299	PNQT2645Z	INDICATION PLATE-LABEL	
	300	PNHR1786Z	GUIDE	PBTRG301A B
	301	PNHR1373Z	PLASTIC PARTS	
	302	PNUS1271Z	TORSION SPRING	
	303	PNDE1050Y	LEVER	PBT
	304	PNUS1270Z	COIL SPRING	
	305	PNHR1372Z	PLASTIC PARTS	
	306	PNUA1044X	CHASSIS	PBTRG301A B
	307	PNUG1021Z	GUIDE	ABS
	308	PNKV1207Z1	COVER	PS-HB
	309	PNKK1081Y1	DOOR-LID	PS-HB
	310	L2AA00000110	THERMISTOR	
	311	PNUS1222Z	TORSION SPRING	
△	312	A4DYYY000004	COIL HEATER	
	313	PNDJ1031Z	SPACER	
	314	PNDS1036Z	ROLLER	
	315	PNDJ1032Z	SPACER	
	316	PFDG1421Y	GEAR	
△	317	K0BDB0000073	THERMOSTAT	
	318	PNJT1154Z	TERMINAL-TERMINAL PLATE	SFWC-F
	319	PNJT1155Z	TERMINAL-TERMINAL PLATE	SFWC-F
△	320	PNJS021097Z	CONNECTOR (MB2230/2270EU only)	
△	320	PNJS021100Z	CONNECTOR (MB2515/2545/2575/310EU only)	
	321	PFMH1085Y	METAL PARTS	
	322	PNHR1712Z	PLASTIC PARTS	
	323	PNDG1055Z	GEAR	
	324	PFDG1423Z	GEAR	
	325	PNUV1045Z	CASE/COVER	PBTRG301A B
	326	PNUA1043V	CHASSIS	PBTRG301A B
	327	PNUS1189Z	BAR SPRING	
	328	PFDR1069Z	ROLLER	
	329	PFUS1640Z	COIL SPRING	
	330	PNDR1038Y	ROLLER	
	331	PNGT7533Z	NAME PLATE, AL (MB2230EU only)	
	331	PNGT7534Z	NAME PLATE, AL (MB2270EU only)	
	331	PNGT7680Z-M	NAME PLATE, AL (MB2515EU only)	
	331	PNGT7683Z-M	NAME PLATE, AL (MB2545EU only)	
	331	PNGT7535Z-M	NAME PLATE, AL (MB2575EU only)	
	331	PNGT7536Z-M	NAME PLATE, AL (MB310EU only)	
	332	PNWEMB2230JT	FUSER UNIT (MB2230/2270EU only)	
	332	PNWEMB2575JT	FUSER UNIT (MB2515/2545/2575/310EU only)	

Safety	Ref. No.	Part No.	Part Name & Description	Remarks
	336	PNHR1818Z	GUIDE (MB310EU only)	POM-M90
	337	PNJS111083Z	CONNECTOR (MB2515/2545/2575/310EU only)	
	338	K1JF11D00002	CONNECTOR (MB2515/2545/2575/310EU only)	
	339	PNUS1275Y	TORSION SPRING (MB2515/2545/2575/310EU only)	SUS304WPB
	340	PNJV1014Z	BRUSH	
	341	PNUG1023Z	GUIDE	ABS
	342	PNUG1022Z	GUIDE	ABS
	343	PNUE1043Z	KEYLOCK	ABS+G10
	344	PNMD1096Y	FRAME	SECC
	345	PNDG1141Z	GEAR	POM-M90
	346	PNDJ1024Y	SPACER (MB2230/2270/2515/2545/2575EU only)	
	346	PNDJ1050Y	SPACER (MB310EU only)	POM-M90
	347	PNDJ1024Z	SPACER (MB2230/2270/2515/2545/2575EU only)	
	347	PNDJ1050Z	SPACER (MB310EU only)	POM-EB
	348	PFDG1627Z	GEAR	
	349	XUC5FJP	RETAINING RING	
	350	PFDJ1044Z	SPACER	
	351	PFDJ1044X	SPACER	
	352	PNHR1846Z	LEVER	POM-M90
	353	PNDR1032Y	ROLLER	
	354	PNHR1845Z	GUIDE	ABS-HB
	355	PNJS031096Z	CONNECTOR	
	356	PNUA1045X	CHASSIS	PS-V0
	357	PNHR1809Y	LEVER	ABS-HB
	358	PNHR1807Z	LEVER	ABS-HB
	359	PNHR1817Y	LEVER	ABS-HB
	360	PNUS1242Z	TORSION SPRING	SUS304WPB
	361	PFDR1069Z	ROLLER	
	362	PFUS1568Z	BAR SPRING	
	363	PNDR1024Z	ROLLER	
	364	PNDJ1017Z	SPACER	
	365	PNDJ1017Y	SPACER	
	366	PNDF1050Z	SHAFT	
	367	PNDV1008Z	ANGULAR BELT	
	368	PNDG1122Z	GEAR	POM-M90
	369	PFDJ1116Z	SPACER	
	370	PNDT1005Z	LEVER	POM-M90
	371	PFNPD041065C	SPACER	
	372	PNUE1041Z	KEYLOCK	PS-HB
	373	PNMH1273Y	METAL PARTS	SECC
	374	PNMD1094Z	FRAME	SECC
	375	PNMH1272Z	METAL PARTS	SECC
	376	PFNPD052080	SPACER	
	377	PNDJ1052Z	SPACER	POM-M90
	378	PFNPD062095	SPACER (MB2230/2270/2515/2545/2575EU only)	
	379	PNJV1012Z	BRUSH	
	380	PNHG1218Z	RUBBER PARTS	EPDM
	381	PNDR1054Z	ROLLER	POM-M90
	382	PNHG1218Z	RUBBER PARTS	
	383	PNDR1055Z	ROLLER	POM-M90
	384	PNUS1273Z	COIL SPRING	
	385	PNHR1870Y	LEVER	POM-M90
	386	PNUS1274Y	TORSION SPRING	SUS304WPB
	387	PNHS1508Z	FELT PARTS	YPB-430
	388	PNDR1051Y	ROLLER	SUM23+EPDM
	389	PNQT2754Z	INDICATION PLATE-LABEL (MB2230/2270EU only)	
	389	PNQT2744Z	INDICATION PLATE-LABEL (MB2515/2545/2575EU only)	
	389	PNQT2755Z	INDICATION PLATE-LABEL (MB310EU only)	
	390	PNQT2743Y	INDICATION PLATE-LABEL	
	391	PFHA1001Z	RUBBER PARTS	
	392	PNUS1154Z	TORSION SPRING	
	393	PFUS1269Y	COIL SPRING	
	394	PNDR1059Z	ROLLER	

18.1.13. LSU Section

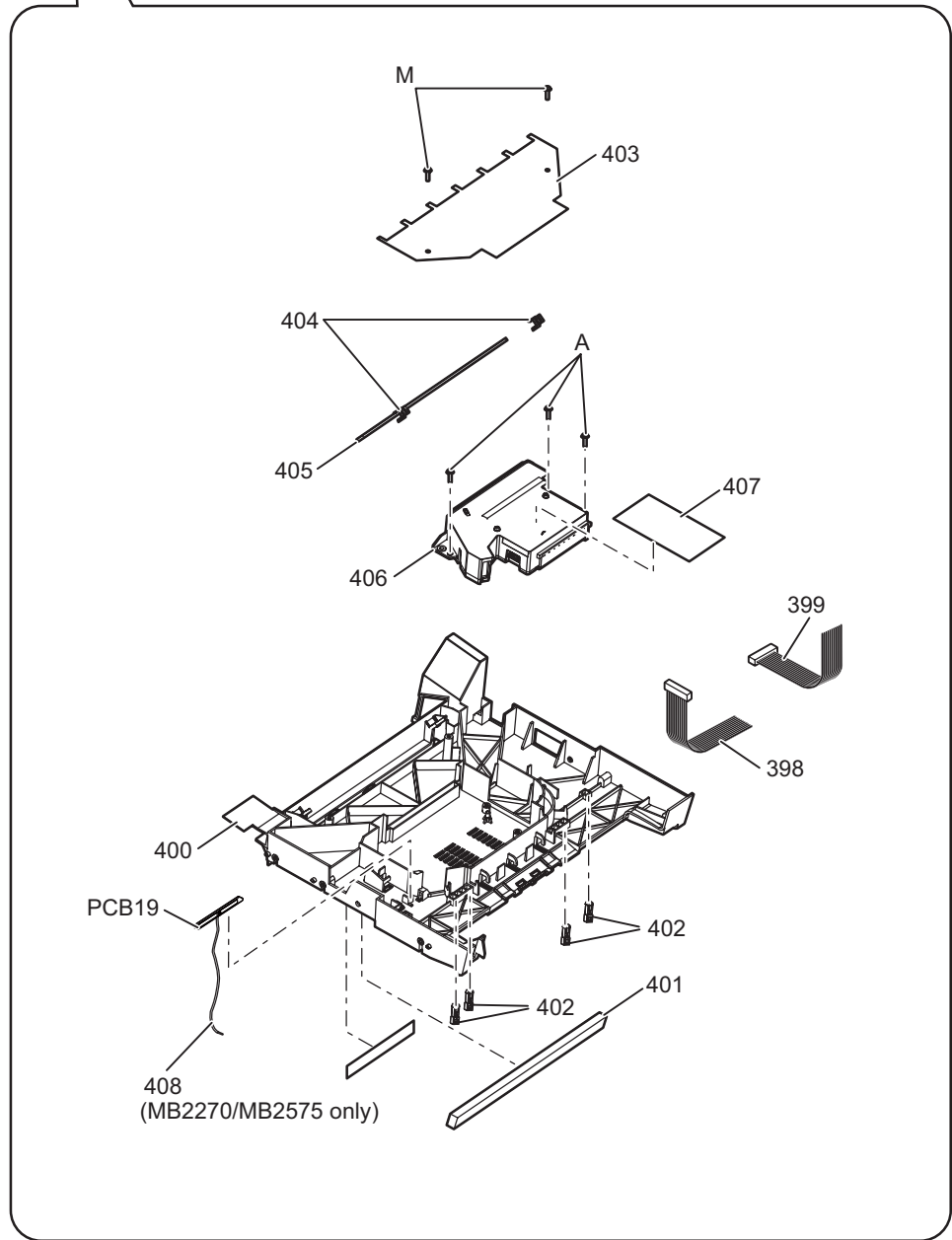
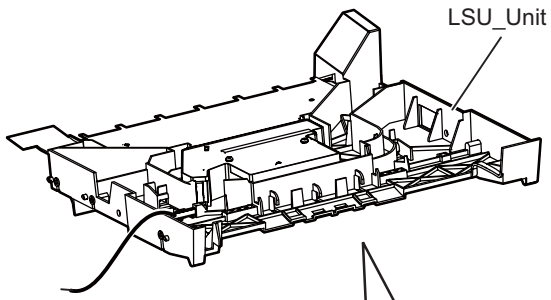

Safety	Ref. No.	Part No.	Part Name & Description	Remarks
	398	PNJS051027Z	CONNECTOR	
	399	PNJS091022Z	CONNECTOR	
	400	PNUE1042Y	KEYLOCK	ABS+GF10
	401	PNHE1011Z	SPACER	
	402	PNUE1027Z	PLASTIC PARTS	
	403	PNHX1665Z	PLASTIC PARTS	PET
	404	PFUS1028Z	LEAF SPRING	
	405	PN0M1003Z	MIRROR	
△	406	LPA1608K	LASER (LASER SCANNING UNIT)	
	407	PNQT1506Z	INDICATION PLATE-LABEL	
	408	PNJS011016Z	CONNECTOR (MB2270/2575EU only)	

18.1.14. Pick-Up Block Section

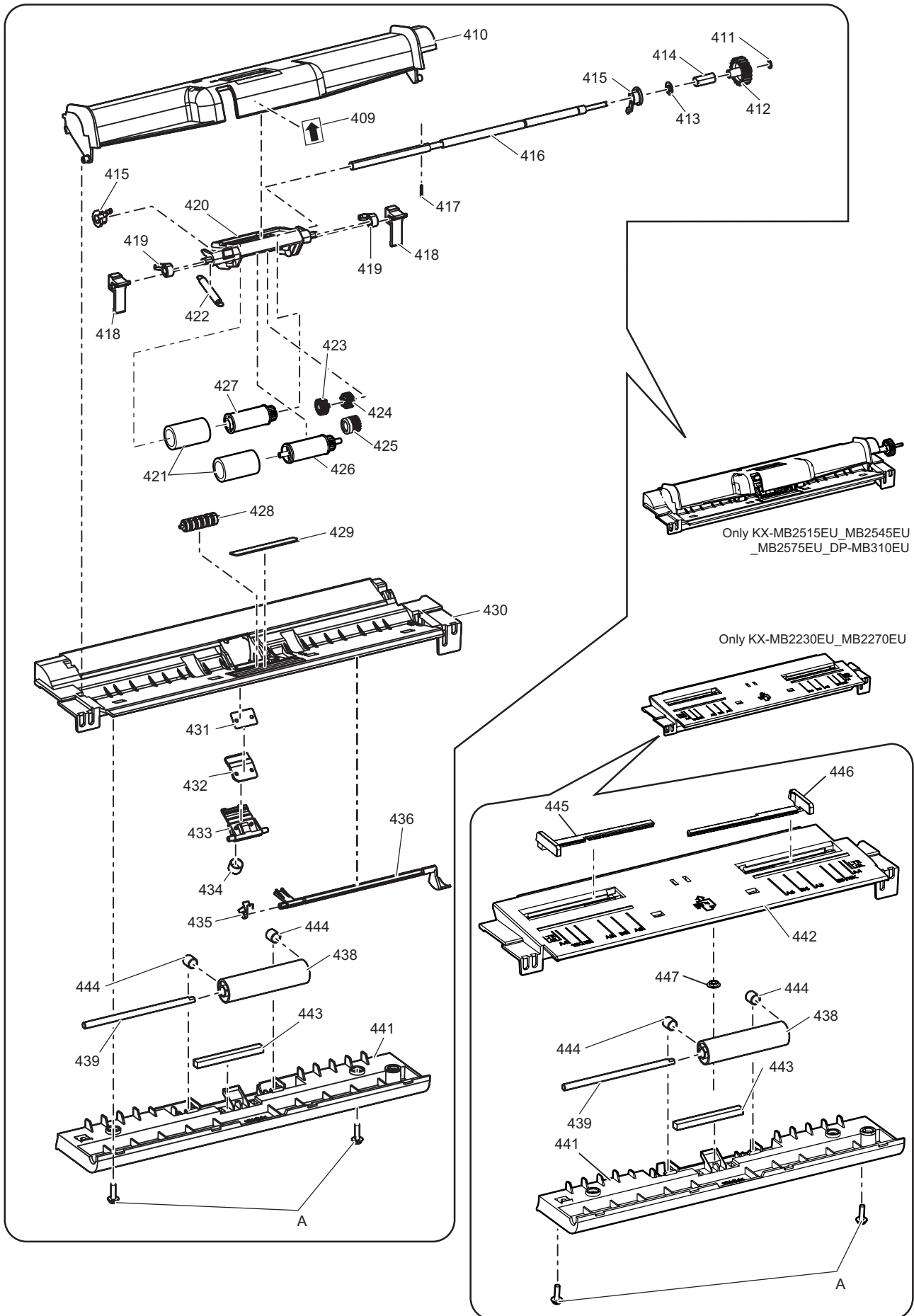

Safety	Ref. No.	Part No.	Part Name & Description	Remarks
	409	PNQT1111Z	INDICATION PLATE-LABEL (MB2515/2545/2575/310EU only)	
	410	PNUG1026Y	GUIDE (MB2515/2545/2575/310EU only)	PS-HB
	411	XUC2FJ	RETAINING RING (MB2515/2545/2575/310EU only)	
	412	PNDG1132Z	GEAR (MB2515/2545/2575/310EU only)	POM-M90
	413	PNNPD041080C	WASHER (MB2515/2545/2575/310EU only)	
	414	PFUS1325Z	COIL SPRING (MB2515/2545/2575/310EU only)	
	415	PFDJ1116Z	SPACER (MB2515/2545/2575/310EU only)	
	416	PNDF1103Z	SHAFT (MB2515/2545/2575/310EU only)	
	417	XPL12A8WUW	KEY-PIN (MB2515/2545/2575/310EU only)	
	418	PFDE1247X	LEVER (MB2515/2545/2575/310EU only)	
	419	PFDE1244Z	LEVER (MB2515/2545/2575/310EU only)	
	420	PNHR1795Y	GUIDE (MB2515/2545/2575/310EU only)	ABS-HB
	421	PNDR1046Z	ROLLER (MB2515/2545/2575/310EU only)	
	422	PNUS1263Z	COIL SPRING (MB2515/2545/2575/310EU only)	
	423	PNDG1129Z	GEAR (MB2515/2545/2575/310EU only)	POM-M90
	424	PNDG1131Z	GEAR (MB2515/2545/2575/310EU only)	POM-M90
	425	PNDG1130Z	GEAR (MB2515/2545/2575/310EU only)	POM-M90
	426	PNDG1128Z	GEAR (MB2515/2545/2575/310EU only)	POM-M90
	427	PNDG1127Z	GEAR (MB2515/2545/2575/310EU only)	POM-M90
	428	PFDR1062Z	ROLLER (MB2515/2545/2575/310EU only)	
	429	PFHG1245Z	RUBBER PARTS (MB2515/2545/2575/310EU only)	
	430	PNUV1048Y	CASE/COVER (MB2515/2545/2575/310EU only)	PS-HB
	431	PNHX1693Z	PLASTIC PARTS (MB2515/2545/2575/310EU only)	
	432	PNHG1242Z	RUBBER PARTS (MB2515/2545/2575/310EU only)	
	433	PNHR1798Z	GUIDE (MB2515/2545/2575/310EU only)	ABS-HB
	434	PNUS1282Z	COIL SPRING (MB2515/2545/2575/310EU only)	
	435	PNUS1264Z	TORSION SPRING (MB2515/2545/2575/310EU only)	
	436	PNDE1059Y	LEVER (MB2515/2545/2575/310EU only)	POM-M90
	437	not used		
	438	PNDR1020Z	ROLLER	
	439	PNDF1038Z	SHAFT	
	440	not used		
	441	PNUE1055X	KEYLOCK	PS-HB
	442	PNUV1050Z1	CASE/COVER (KX-MB2230/KX-MB2270 only)	ABS-H
	443	PFHE1178Z	SPACER	
	444	PNUS1265Z	COIL SPRING	SUS304WPB
	445	PFKR1079Z2	GUIDE (MB2230/2270EU only)	
	446	PFKR1080Z2	GUIDE (MB2230/2270EU only)	
	447	PFDG1015Y	GEAR (MB2230/2270EU only)	

18.1.15. Paper Feed Section

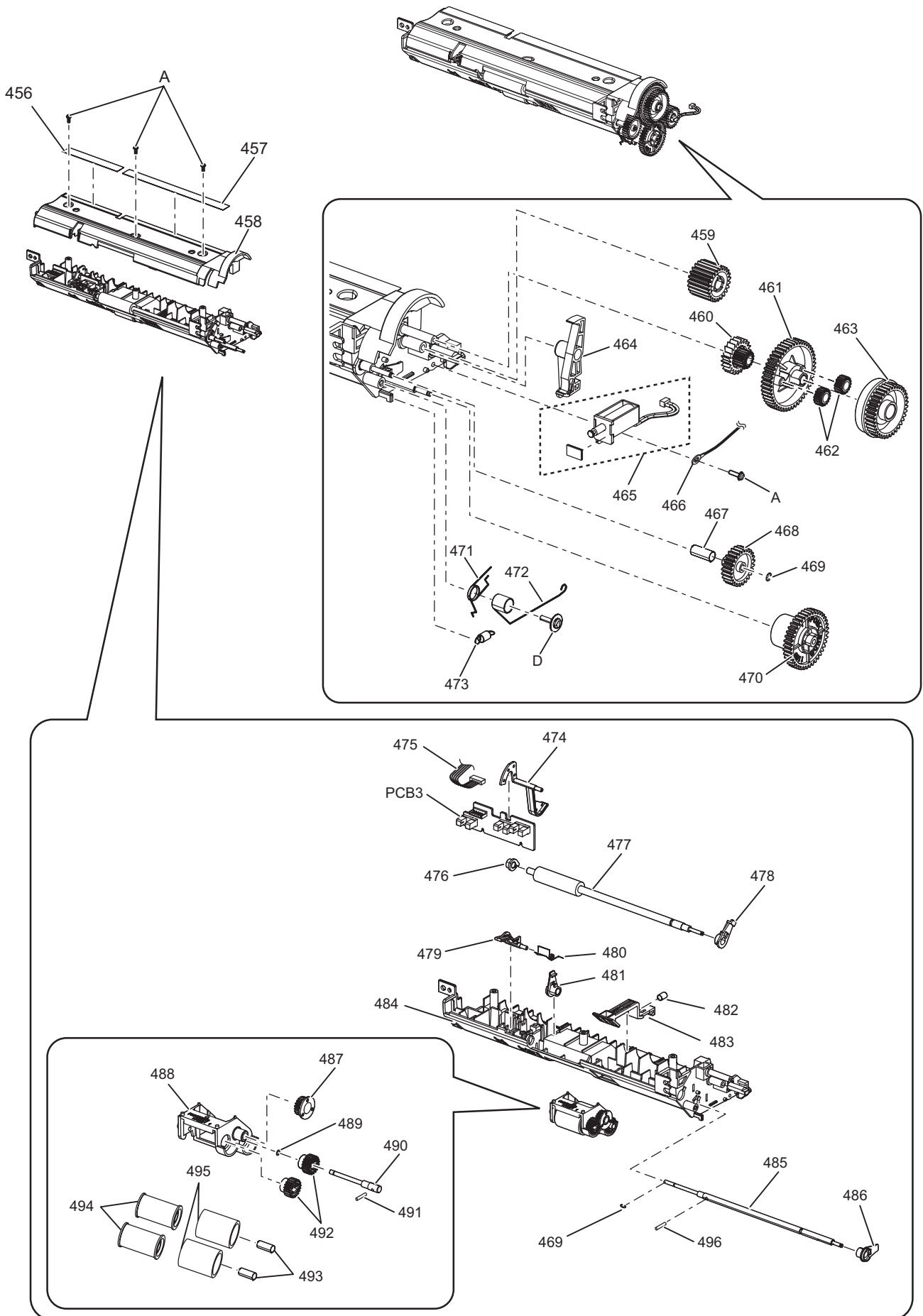

Safety	Ref. No.	Part No.	Part Name & Description	Remarks
	456	PNHX1639Z	PLASTIC PARTS	
	457	PNHX1638Z	PLASTIC PARTS	
	458	PNUV1058Y	CASE/COVER	PS-HB
	459	PNDG1142Z	GEAR	POM-M90
	460	PNDG1146Y	GEAR	POM-M90
	461	PNDG1120Z	GEAR	POM-M90
	462	PFDG1576Z	GEAR	
	463	PNDG1121Z	GEAR	POM-M90
	464	PNDE1061Y	LEVER	POM-M90
	465	PNWXMB2230JT	SOLENOID ASS'Y	
	466	PNVW1041Z	CONNECTOR	
	467	PQUS10038Z	COIL SPRING	
	468	PNDG1119Z	GEAR	POM-M90
	469	XUC2FJ	RETAINING RING	
	470	PNDG1108Y	GEAR	POM-M90
	471	PNUS1237Z	TORSION SPRING	
	472	PNUS1238Z	BAR SPRING	
	473	PNUS1240Y	COIL SPRING	
	474	PNHR1792Z	LEVER	POM-M90
	475	PNJS061019Z	CONNECTOR	
	476	PFDJ1116Z	SPACER	
	477	PNDR1052X	ROLLER	EPDM/ SUM23
	478	PFDJ1044X	SPACER	
	479	PNHR1791Z	LEVER	POM-M90
	480	PNUS1239Z	TORSION SPRING	SUS304WPB
	481	PFDJ1084Z	SPACER	
	482	PNUS1236Z	COIL SPRING	SUS304WPB
	483	PNHR1805Y	LEVER	ABS-HB
	484	PNUG1031Y	GUIDE (MB2230/2270EU only)	PS-HB
	484	PNUG1031X	GUIDE (MB2515/2545/2575/310EU only)	
	485	PNDF1111Y	SHAFT	SUM23
	486	PFDJ1084X	SPACER	
	487	PNDG1111Z	GEAR	POM-M90
	488	PNHR1790Z	GUIDE	ABS-HB
	489	XUC2FJ	RETAINING RING	
	490	PNDF1112Y	SHAFT	SUM23
	491	XPJ2A8VWM2	KEY-PIN	
	492	PNDG1110Y	GEAR	POM-M90
	493	PFUS1812Z	COIL SPRING	
	494	PNDR1058Z	ROLLER	PS-HB
	495	PNDV1007Z	ANGULAR BELT	EPDM Rub- ber
	496	XPJ2A8VWM2	KEY-PIN	

Safety	Ref. No.	Part No.	Part Name & Description	Remarks
	503	PNMD1095Z	FRAME	SECC
	504	PFUS1502Z	TORSION SPRING (MB2230/2270/2545/2575/310EU only)	
	505	PNUS1252Z	BAR SPRING	SUS304WPB
	506	PNUS1262Z	BAR SPRING	SUS304WPB
	507	PNUS1251Z	BAR SPRING	SUS304WPB
	508	PNHR1810Z	GUIDE	PS-V0
	509	PNMC1093Y	MAGNETIC SHIELD	SECC
	510	PNMC1092Z	MAGNETIC SHIELD	SECC
	511	PNKV1206Y1	COVER (MB2230/2270/2545/2575/310EU only)	PS-HB
	511	PNKV1206W1	COVER (MB2515EU only)	
	512	PNUS1256Z	COIL SPRING	SUS304WPB
	513	PNUS1257Z	COIL SPRING	SUS304WPB
	514	PNUS1253Z	COIL SPRING	SUS304WPB
	515	PNUS1250Z	COIL SPRING	SUS304WPB
	516	PNUS1243Z	TORSION SPRING	SUS304WPB
	517	PNUS1249Z	COIL SPRING	SUS304WPB
	518	PNUS1247Z	COIL SPRING	SUS304WPB
	519	PNUS1254Z	TORSION SPRING	SUS304WPB
	520	PNUS1248Z	COIL SPRING	SUS304WPB
	521	L0AA05A00048	SPEAKER (MB2230/2270/2545/2575/310EU only)	
	522	PNJS021092Z	CONNECTOR (MB2230/2270/2545/2575/310EU only)	
△	523	K2AHYG000007	JACK/SOCKET	
	524	PQMX10010Z	CASE/COVER	
	525	JOKE00000114	INSULATOR	
△	526	PNVW1014Z	CONNECTOR	
△	527	PNWLCC17GGXX	LEAD WIRE	
△	528	PNWLCAL8GGXX	LEAD WIRE	
	529	PQHR945Z	BAND	
	530	not used		
	531	XWC4BFJ	WASHER	
	532	PNHR1808Z	PLATE	PS-V0
	533	PQHR945Z	BAND	
	534	PNJS021094Z	CONNECTOR	
	535	PNJS021095Z	CONNECTOR	
	536	PNJS061021Z	CONNECTOR	
	537	PNJS061020Z	CONNECTOR	
	538	PNJS041046Z	CONNECTOR	
	539	not used		
	540	PNJS061023Z	CONNECTOR	
	541	PNJS101015Z	CONNECTOR	
	542	PNVW1044Z	CONNECTOR	
	543	PNHX1647Y	PLASTIC PARTS	PC/VTM-0
	544	JOKE00000115	INSULATOR, CORE	
	545	PNKV1219Z1	COVER	PS-HB
	546	PNKV1208Z1	COVER (MB2230/2270EU only)	PS-HB
	546	PNKV1222Z1	COVER (MB2515/2545/2575EU only)	PS-HB
	546	PNKV1222Z2	COVER (MB310EU only)	PS-HB
	547	PNBC1503Z1	PUSH BUTTON, ON OFF KEY (MB2230/2270/2515/2545/2575EU only)	ABS-HB
	547	PNBC1503Z2	PUSH BUTTON, ON OFF KEY (MB310EU only)	ABS-HB
	548	PNJS021093Z	CONNECTOR	
	549	PNMH1268Z	METAL PARTS (MB2515/2545/2575/310EU only)	SECC
	550	PNJS051028Z	CONNECTOR (MB2515/2545/2575/310EU only)	
	551	PNJS011015Z	CONNECTOR (MB2270/2575EU only)	
△	552	PNJS021099Z	CONNECTOR (MB2515/2545/2575/310EU only)	
	553	PQHR945Z	BAND (MB2515/2545/2575/310EU only)	

18.1.17. Right Side Cabinet Section (1)

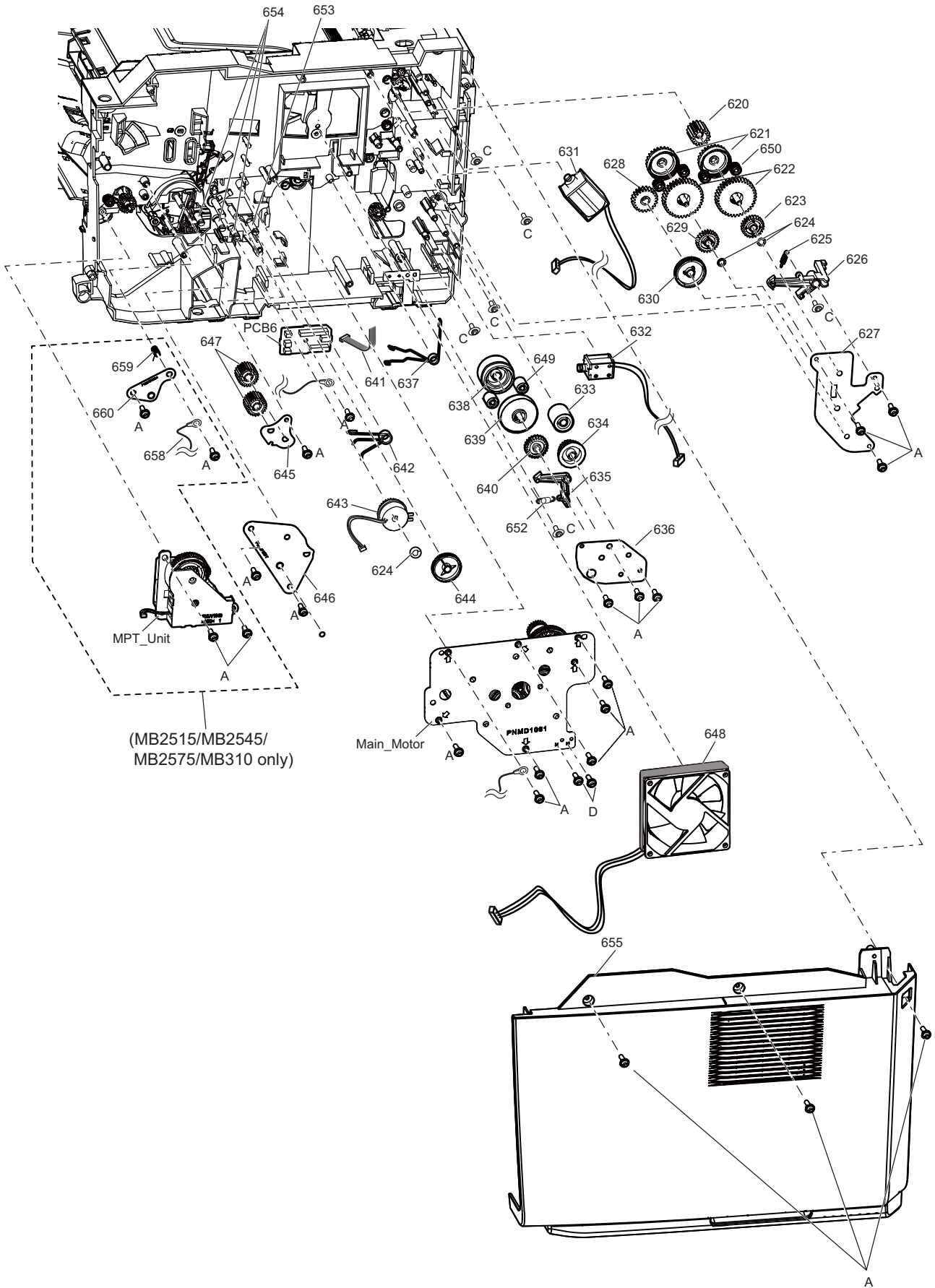

Safety	Ref. No.	Part No.	Part Name & Description	Remarks
	620	PNDG1027Z	GEAR	
	621	PFDG1605Z	GEAR	
	622	PJDGB0168Z	GEAR	
	623	PJDGB0167Z	GEAR	
	624	PFNPD052080	SPACER	
	625	PNUS1227Z	COIL SPRING	SUS304WPB
	626	PNDE1053Z	LEVER	POM-M90
	627	PNHX1641Z	PLASTIC PARTS	PC
	628	PFDG1622Z	GEAR	
	629	PJDGB0166Z	GEAR	
	630	PNDG1118Z	GEAR	POM-M90
	631	L9AAAYB0025	ERECTROMAGNETIC COIL	
	632	L9AAAYB0023	ERECTROMAGNETIC COIL	
	633	PFDG1391Z	GEAR	
	634	PNDG1117Z	GEAR	POM-M90
	635	PNDE1052Z	LEVER	POM-M90
	636	PNHX1640Y	PLASTIC PARTS	PS-HB
	637	PNUS1244Z	TORSION SPRING	SUS304WPB
	638	PFDG1404Z	GEAR	
	639	PFDG1402Z	GEAR	
	640	PFDG1547Z	GEAR	
	641	PNJS081094Z	CONNECTOR	
	642	PNUS1255Z	TORSION SPRING	SUS304WPB
	643	L9EAAY000002	CLUTCH	
	644	PNDG1116Z	GEAR	POM-M90
	645	PNMH1283Z	METAL PARTS	SECC
	646	PNMH1277Z	METAL PARTS	SECC
	647	PNDG1142Z	GEAR	
	648	PNWQMB2230JT	FAN	
	649	PFDG1403Z	GEAR	
	650	PFDG1606Z	GEAR	
	651	not used		
	652	PFUS1896Z	COIL SPRING	
	653	PNDF1110Z	SHAFT	SUM23+Ni
	654	PNDF1054Z	SHAFT	
	655	PNKV1205Z1	COVER	PS-HB
	656	not used		
	657	not used		
	658	PNVW1042Z	CONNECTOR (MB2515/2545/2757/310EU only)	
	659	PNUS1272Z	TORSION SPRING (MB2515/2545/2757/310EU only)	
	660	PNMH1284Z	METAL PARTS (MB2515/2545/2757/310EU only)	

18.1.18. Right Side Cabinet Section (2)

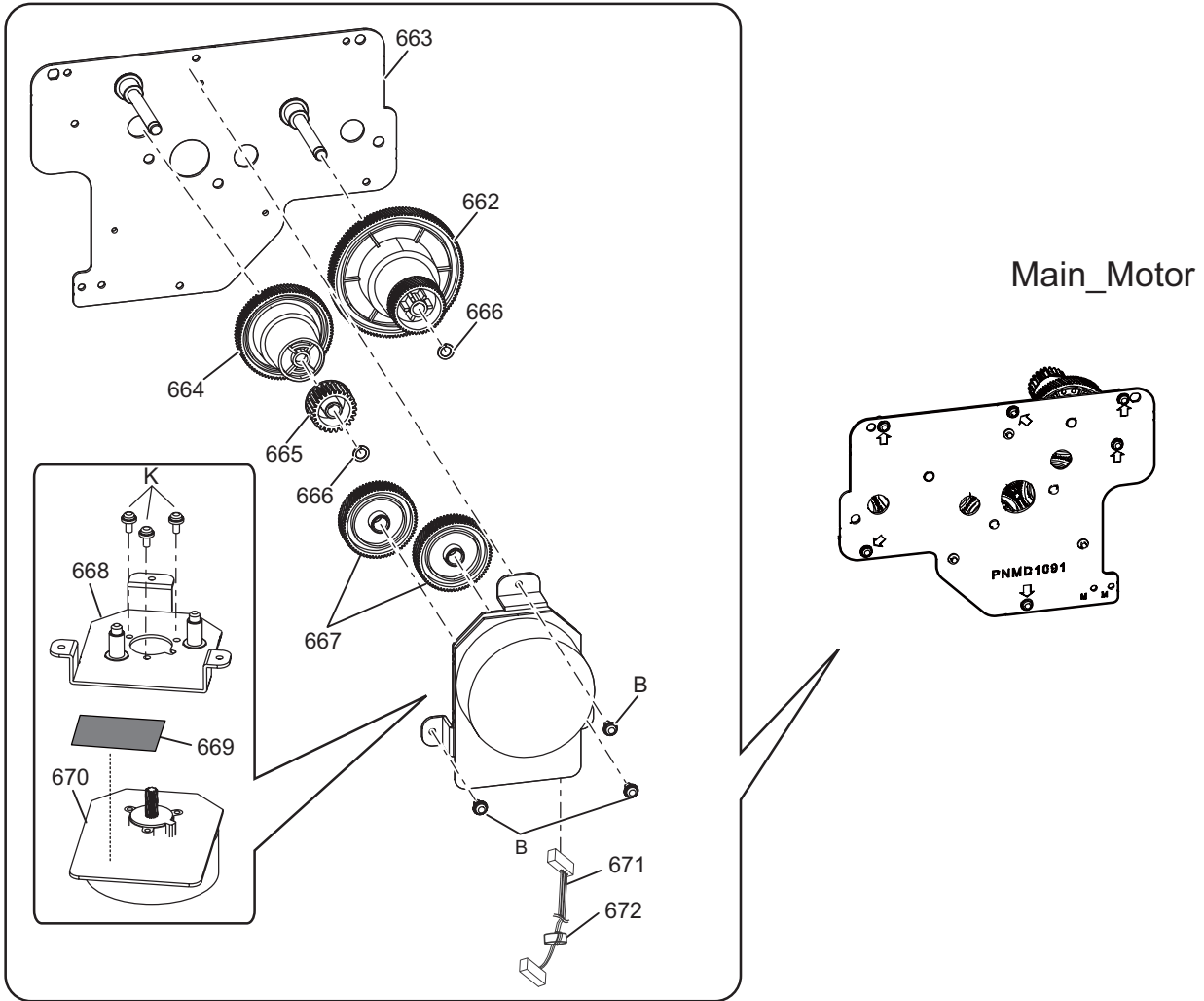

MPT-Unit

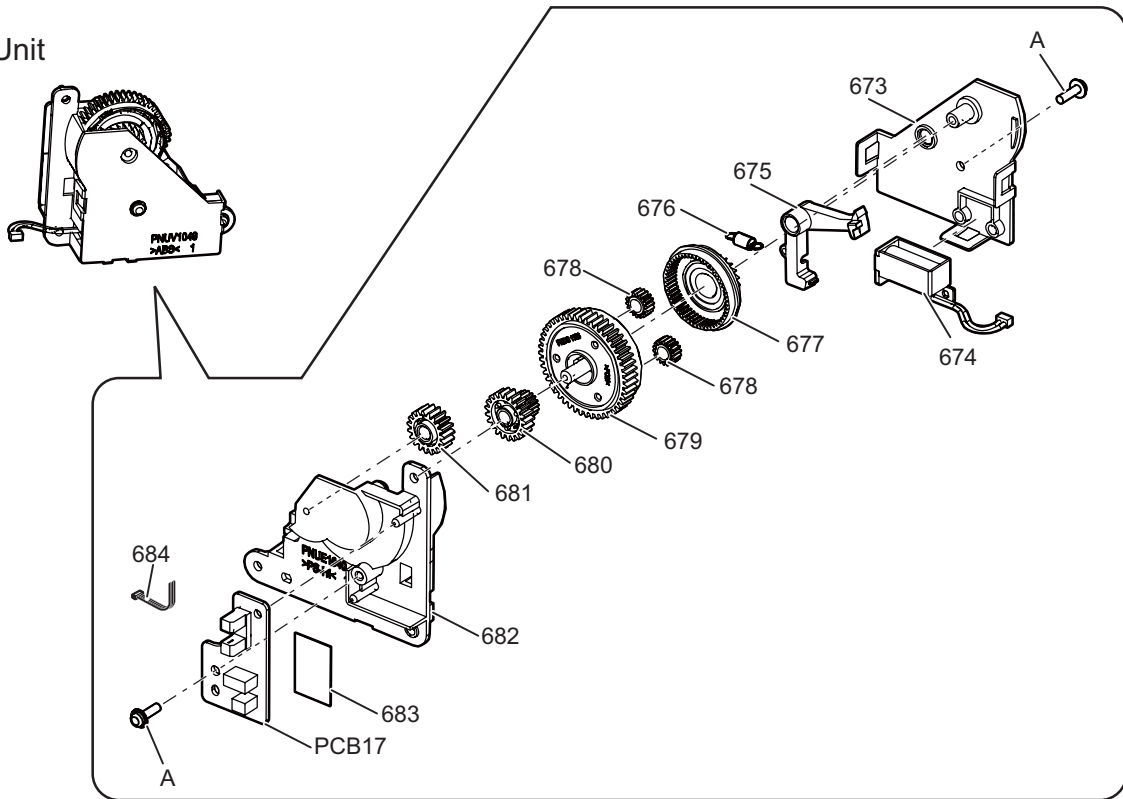

Only MB2515EU_MB2545EU_MB2575EU_MB310EU

Safety	Ref. No.	Part No.	Part Name & Description	Remarks
	662	PNDG1112Z	GEAR	POM-M90
	663	PNZF2B2230JT	MAIN DRIVE SHUFT ASS'Y	
	664	PNDG1114Z	GEAR	POM-M90
	665	PNDG1115Z	GEAR	Polyamide
	666	PFNPD052080	SPACER	
	667	PNDG1113Z	GEAR	POM-M90
	668	PNZF1B2230JT	MAIN MOTOR SHUFT ASS'Y	
	669	PFHX2126Z	PLASTIC PARTS	
	670	L6CCYYK0008	DC MOTOR	
	671	PNJS081097Z	CONNECTOR	
	672	J0KE00000114	INSULATOR CORE	
	673	PNUV1049Z	CASE/COVER (MB2515/2545/2575/310EU only)	ABS-HB
	674	L9AAAYB0027	ERECTROMAGNETIC COIL (MB2515/2545/2575/310EU only)	
	675	PNDE1060Y	LEVER (MB2515/2545/2575/310EU only)	POM-M90
	676	PNUS1281Z	COIL SPRING (MB2515/2545/2575/310EU only)	
	677	PNDG1134Z	GEAR (MB2515/2545/2575/310EU only)	POM-M90
	678	PFDG1576Z	GEAR (MB2515/2545/2575/310EU only)	
	679	PNDG1133Z	GEAR (MB2515/2545/2575/310EU only)	POM-M90
	680	PNDG1135Z	GEAR (MB2515/2545/2575/310EU only)	POM-M90
	681	PNDG1136Z	GEAR (MB2515/2545/2575/310EU only)	POM-M90
	682	PNUE1040Z	KEYLOCK (MB2515/2545/2575/310EU only)	PS-HB
	683	PNHX1658Z	PLASTIC PARTS (MB2515/2545/2575/310EU only)	PET
	684	PNJS041047Z	CONNECTOR (MB2515/2545/2575/310EU only)	

18.1.19. Standard Input Tray Section

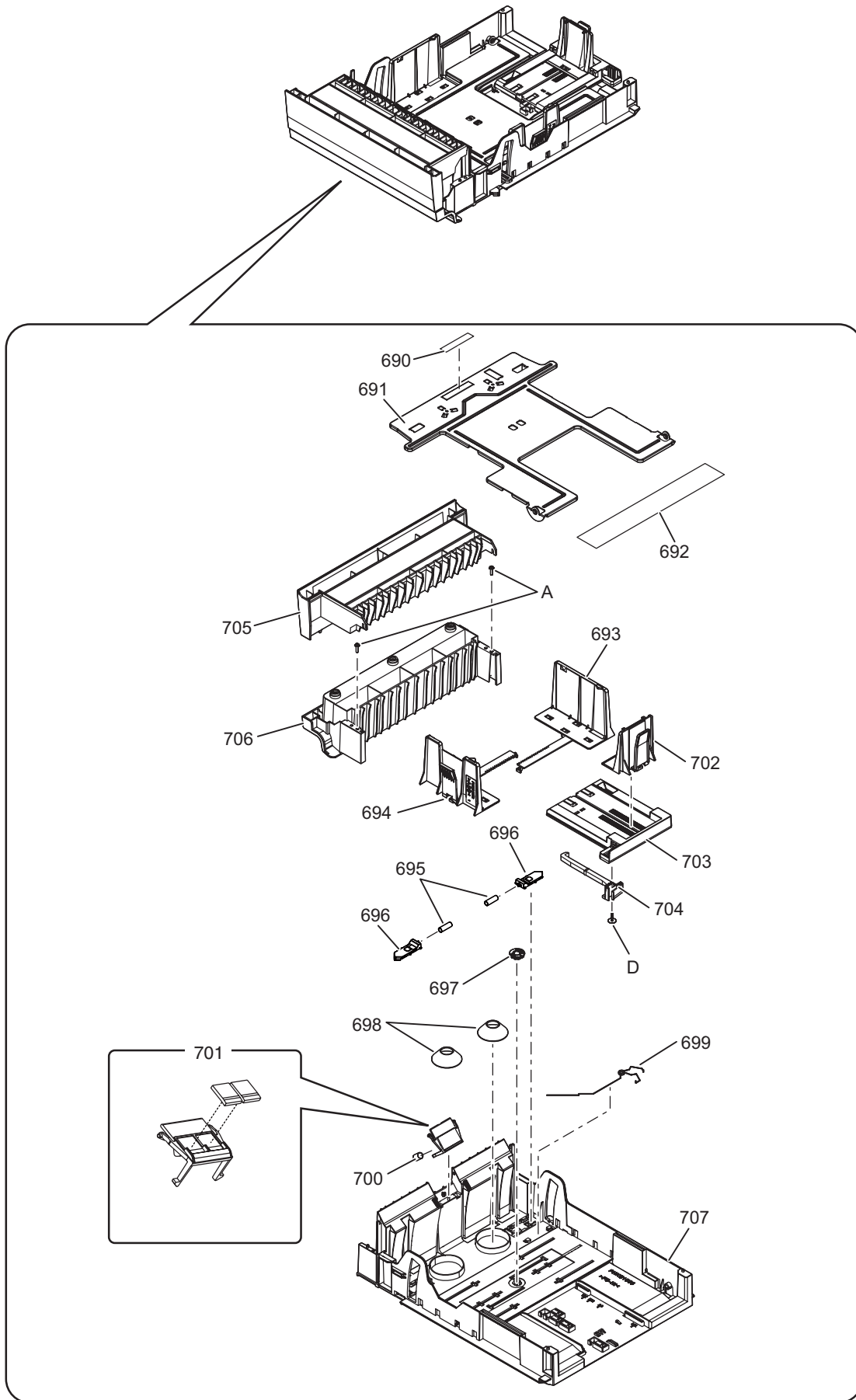

Safety	Ref. No.	Part No.	Part Name & Description	Remarks
	690	PFHG1245Z	RUBBER PARTS	
	691	PNMD1093X	FRAME	SECC
	692	PNQT2647Z	INDICATION PLATE-LABEL	
	693	PNKR1031Z	GUIDE	ABS-HB
	694	PNKR1032Z	GUIDE	ABS-HB
	695	PNUS1241Z	COIL SPRING	SUS304WPB
	696	PNHR1368Z	PLASTIC PARTS	
	697	PFDG1569Z	GEAR	
	698	PNUS1226Y	LEAF SPRING	SUS304WPB
	699	PNUS1225Z	TORSION SPRING	SUS304WPB
	700	PFUS1620Z	COIL SPRING	
	701	PNYC2B2230JT	FRAME	
	702	PNKR1028Z	GUIDE	ABS-HB
	703	PNHR1796Z	TRAY	ABS-HB
	704	PNHR1801Y	LEVER	ABS-HB
	705	PNKV1212Y1	COVER (MB2230/2270/2515/2545/2575EU only)	PS-HB
	705	PNKV1212Y2	COVER (MB310EU only)	PS-HB
	706	PNKV1209Z1	COVER	PS-HB
	707	PNKS1033V	TRAY	

18.1.20. Front Cover Section

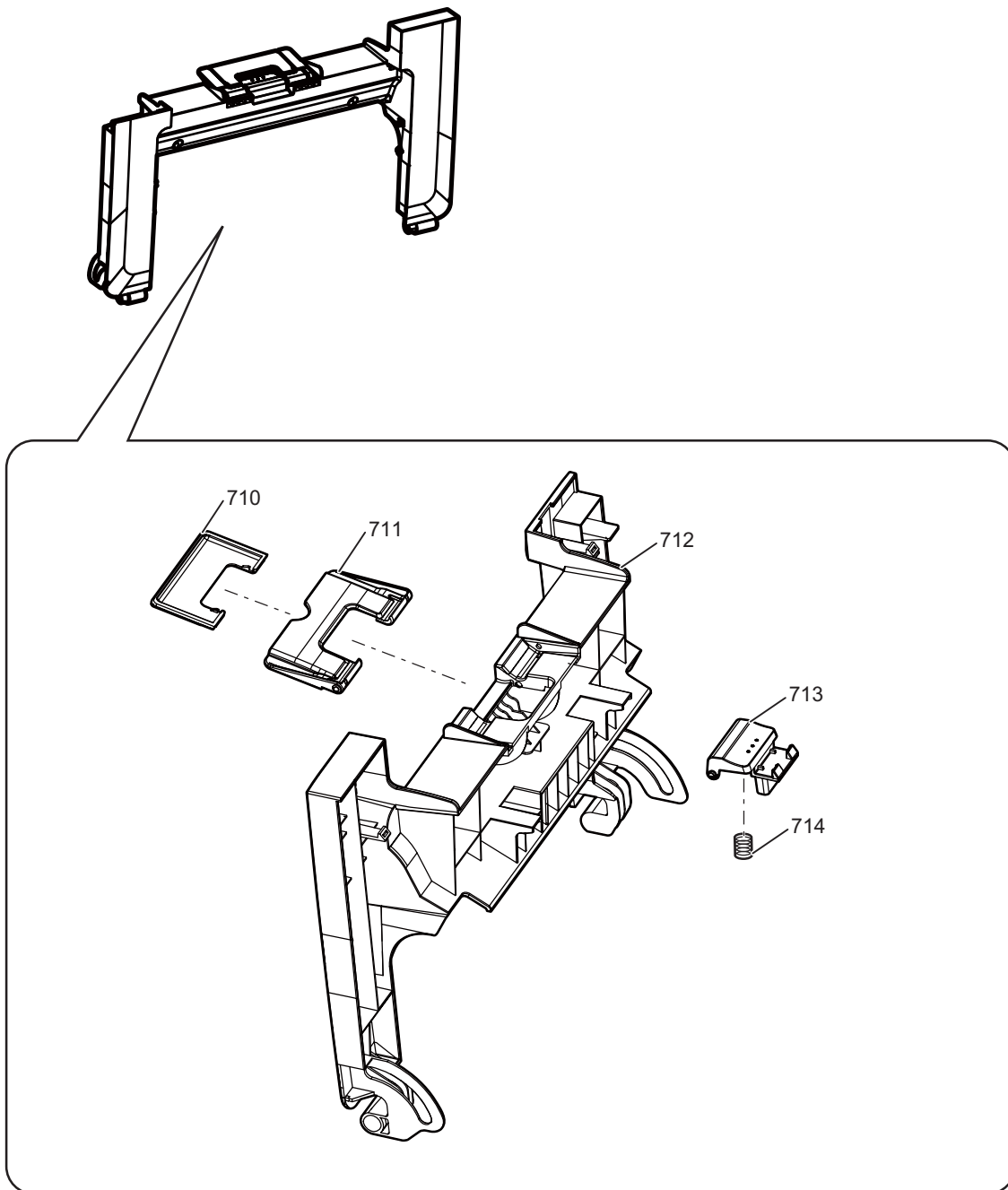

Safety	Ref. No.	Part No.	Part Name & Description	Remarks
	710	PNKS1039Z1	TRAY (MB2230/2270/2515/2545/2575EU only)	PS-HI-HB
	710	PNKS1039Z2	TRAY (MB310EU only)	PS-HI-HB
	711	PNKS1038Y1	TRAY (MB2230/2270/2515/2545/2575EU only)	PS-HI-HB
	711	PNKS1038Y2	TRAY (MB310EU only)	PS-HI-HB
	712	PNKK1080Z1	DOOR-LID (MB2230/2270/2515/2545/2575EU only)	PS-HB
	712	PNKK1080Z2	DOOR-LID (MB310EU only)	PS-HB
	713	PNHR1787Z1	LEVER	ABS-HB
	714	PNUS1034Z	COIL SPRING	

18.1.21. Manual Tray Section

Manual Tray(Single) Section

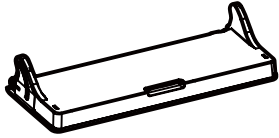

Only MB2230EU_MB2270EU

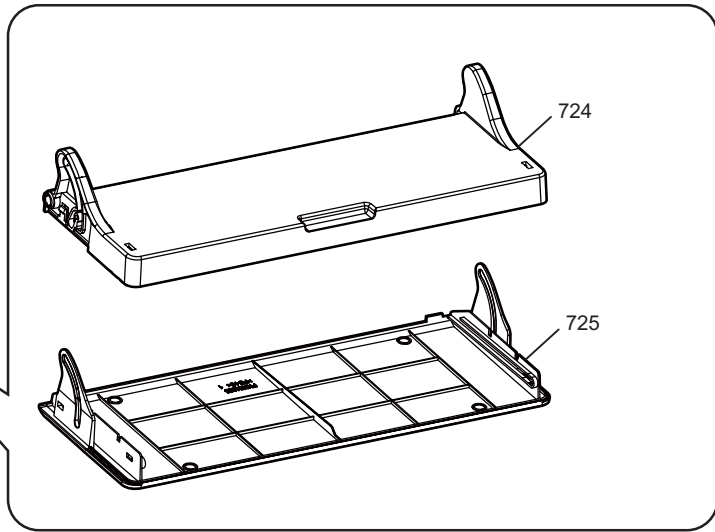

Manual Tray(Multi) Section

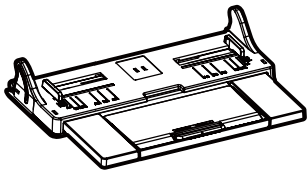



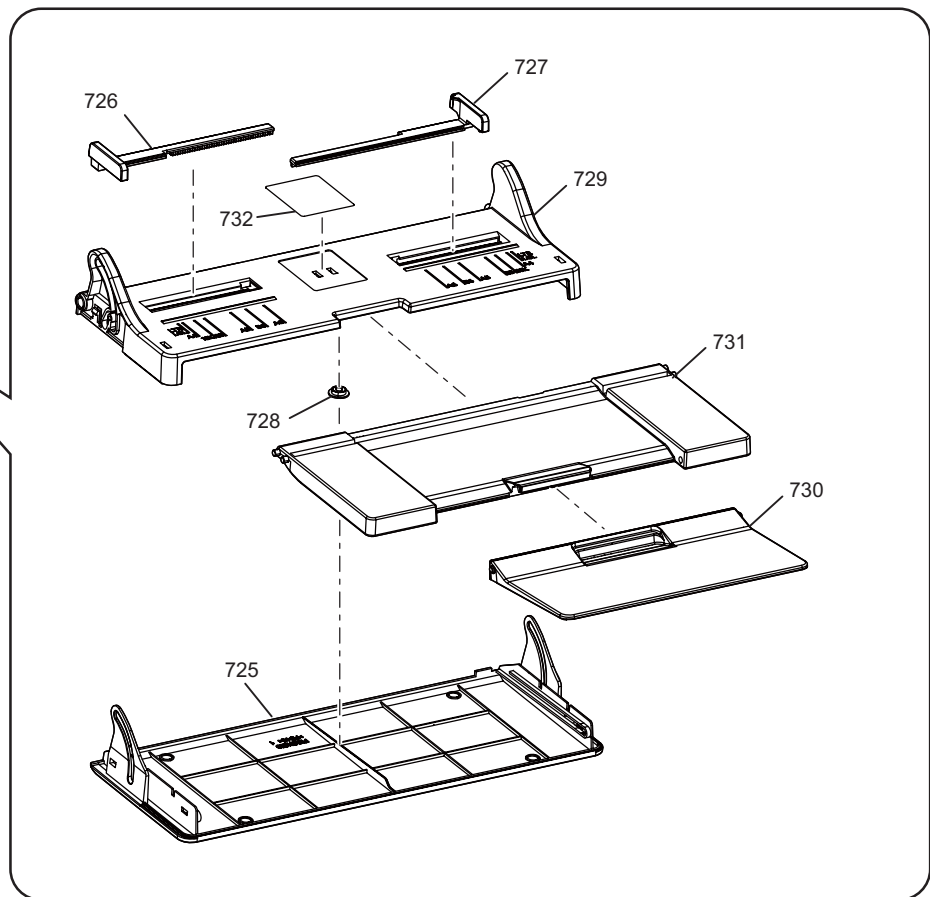



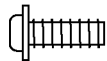

Only MB2515EU_MB2545EU_MB2575EU_MB310EU

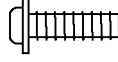
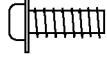

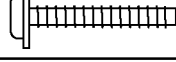
Safety	Ref. No.	Part No.	Part Name & Description	Remarks
	724	PNKS1037Z	TRAY (MB2230/2270EU only)	PS-HB
	725	PNKE1283Z1	COVER (MB2230/2270/2515/2545/2575EU only)	PS-HB
	725	PNKE1283Z2	COVER (MB310EU only)	PS-HB
	726	PFKR1080Z2	GUIDE (MB2515/2545/2575EU only)	
	726	PFKR1080Z3	GUIDE (MB310EU only)	
	727	PFKR1079Z2	GUIDE (MB2515/2545/2575EU only)	
	727	PFKR1079Z3	GUIDE (MB310EU only)	
	728	PFDG1015Y	GEAR (MB2515/2545/2575/310EU only)	
	729	PNKE1284Z2	COVER (MB2515/2545/2757/310EU only)	PS-HB
	730	PNKS1036Z1	TRAY (MB2515/2545/2757EU only)	PS-HB
	730	PNKS1036Z2	TRAY (MB310EU only)	PS-HB
	731	PNKS1035Z1	TRAY (MB2515/2545/2757EU only)	PS-HB
	731	PNKS1035Z2	TRAY (MB310EU only)	PS-HB
	732	PNQT2696Z	INDICATION PLATE-LABEL (MB2515/2545/2757EU only)	
	732	PNQT2697Z	INDICATION PLATE-LABEL (MB310EU only)	

18.1.22. Actual Size of Screws and Washer

		Illustration
Ⓐ	XTW3+10PFJ7	
Ⓑ	XTW3+6LFJ7	
Ⓒ	XTW3+12PFJ7	
Ⓓ	XTW3+W10PFJ	
Ⓔ	XSB4+6FJ	
Ⓕ	XYN3+F8FJ	
Ⓖ	XTW3+20PFJ	
Ⓗ	XYC3+FF8FJ	
Ⓚ	XYN3+F6FJ	
Ⓛ	XYC3+CF5FJ	
Ⓜ	XTB3+6GFJM3	

Safety	Ref. No.	Part No.	Part Name & Description	Remarks
	A	XTW3+10PFJ7	TAPPING SCREW, STEEL	
	B	XTW3+6LFJ7	TAPPING SCREW, STEEL	
	C	XTW3+12PFJ7	TAPPING SCREW, STEEL	
	D	XTW3+W10PFJ	TAPPING SCREW, STEEL	
	E	XSB4+6FJ	SMALL SCREW, STEEL	
	F	XYN3+F8FJ	SCREW WITH WASHER, STEEL	
	G	XTW3+20PFJ	TAPPING SCREW, STEEL	
	H	XYC3+FF8FJ	SCREW WITH WASHER, STEEL	
	K	XYN3+F6FJ	TAPPING SCREW, STEEL	
	L	XYC3+CF5FJ	SCREW WITH WASHER, STEEL	
	M	XTB3+6GFJM3	TAPPING SCREW, STEEL	

18.1.23. Accessories and Packing Materials

(MB2515/MB2545/MB2575/MB310 only)

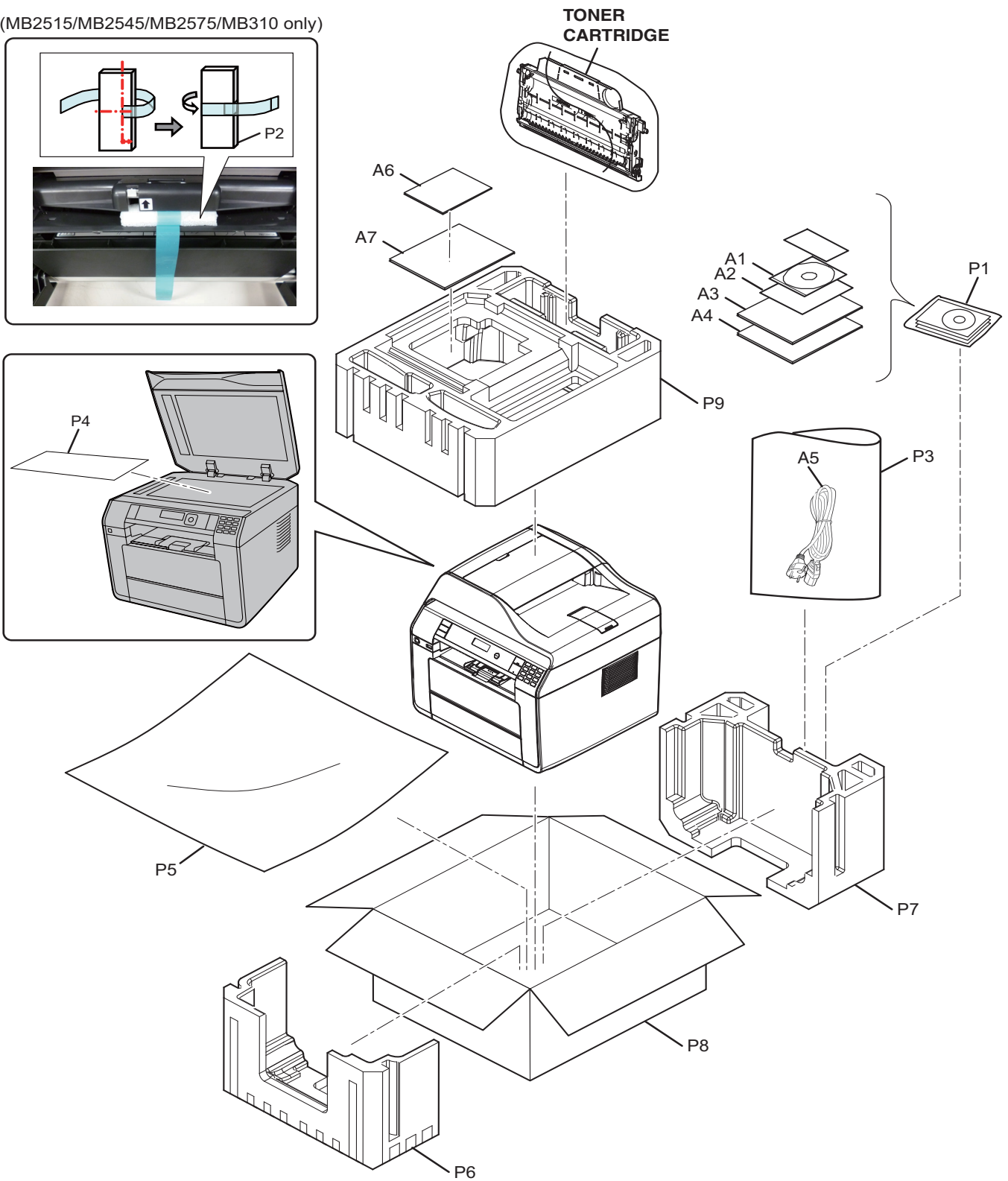

Safety	Ref. No.	Part No.	Part Name & Description	Remarks
	A1	PNJKMB2230Z	MEMORY PARTS (for KX-MB2230/KX-MB2270)	
	A1	PNJKMB2575Z	MEMORY PARTS (for KX-MB2515/KX-MB2545/KX-MB2575/DP-MB310)	
	A2	PNQW3207Z	LEAFLET, Lot4	
	A3	PNQW3647Z	LEAFLET, IIG(English for EU)	
	A4	PNQW3722Z	LEAFLET, Operation panel guide	
△	A5	PNJA1094Z	POWER CORD	
	A6	PNQW3830Z	LEAFLET	
	A7	PNQW3721Z	LEAFLET, QIG	
	P1	PNPP1100Z	PROTECTION COVER	
	P2	PFPB1001Z	CUSHION (KX-MB2515/KX-MB2545/KX-MB2575/DP-MB310 only)	
	P3	PNPP1119Z	PROTECTION COVER	
	P4	PNPH1027X	PACKING SHEET	
	P5	PNPP1149Z	PROTECTION COVER	
	P6	PNPN1378X	CUSHION	
	P7	PNPN1379X	CUSHION	
	P8	PNPK3704002Y	GIFT BOX (for KX-MB2230)	
	P8	PNPK3704004Z	GIFT BOX (for KX-MB2270)	
	P8	PNPK3704006Z	GIFT BOX (for KX-MB2515)	
	P8	PNPK3704005Z	GIFT BOX (for KX-MB2545)	
	P8	PNPK3704001Z	GIFT BOX (for KX-MB2575)	
	P8	PNPK3704030Z	GIFT BOX (for DP-MB310)	
	P9	PNPN1377X	CUSHION	

18.2. Electrical Parts List

18.2.1. Main Board (For KX-MB2230EU)

Safety	Ref. No.	Part No.	Part Name & Description	Remarks
	PCB1	PNWP1B2230EU	MAIN BOARD ASS'Y (RTL)	
			(ICs)	
	IC100	C1CB00002689	IC	
	IC101	C1CB00002690	IC	
	IC201	C1CB00001769	IC	
	IC203	C1AB00002556	IC	
	IC300	C1ZBZ0004649	IC	
	IC301	C0EBY0000665	IC	
	IC302	C0ZBZ0001747	IC	
	IC303	C0DBGYY03947	IC	
	IC400	C3ABRY000078	IC	
	IC401	C3ABRY000078	IC	
	IC402	PNWI2230EU	IC (ROM)	
	IC403	C0JBAZ001466	IC	
	IC404	C0JBAZ001466	IC	
	IC405	C0JBAZ001539	IC	
	IC406	C0JBAZ001539	IC	
	IC407	C0JBAA000362	IC	
	IC500	C1ZBZ0003879	IC	
	IC502	AN44071A	IC	
	IC503	C0FBAY000092	IC	
	IC504	C0BBBA000024	IC	
	IC750	C1CB00003704	IC	
	IC800	C0DBAYY01433	IC	
	IC801	C0DBAYY01433	IC	
	IC802	C0DBAYY00932	IC	
	IC803	C0DBEYY00102	IC	
			(TRANSISTORS)	
	Q100	DSC710100L	TRANSISTOR (SI)	
	Q101	DSC710100L	TRANSISTOR (SI)	
	Q102	B1ABDP000005	TRANSISTOR (SI)	
	Q103	B1ABDP000005	TRANSISTOR (SI)	
	Q104	B1ADGP000008	TRANSISTOR (SI)	
	Q105	DRC9123J0L	TRANSISTOR (SI)	
	Q200	B1GBCFGN0005	TRANSISTOR (SI)	
	Q500	DSC9001R0L	TRANSISTOR (SI)	
	Q501	B1GBCFGN0005	TRANSISTOR (SI)	
	Q502	B1GBCFGN0005	TRANSISTOR (SI)	
	Q503	B1GBCFGN0005	TRANSISTOR (SI)	
	Q504	B1GBCFGN0005	TRANSISTOR (SI)	
	Q505	B1GBCFGN0005	TRANSISTOR (SI)	
	Q506	B1GBCFGN0005	TRANSISTOR (SI)	
	Q507	B1ABGE000014	TRANSISTOR (SI)	
	Q509	B1ADKE000002	TRANSISTOR (SI)	
	Q510	B1ABGE000014	TRANSISTOR (SI)	
	Q511	B1ABGE000014	TRANSISTOR (SI)	
	Q513	B1GBCFGN0005	TRANSISTOR (SI)	
	Q514	B1ABGE000011	TRANSISTOR (SI)	
	Q516	B1ABGE000011	TRANSISTOR (SI)	
	Q517	B1ABGE000011	TRANSISTOR (SI)	
	Q518	B1ADGE000012	TRANSISTOR (SI)	
	Q520	B1GBCFGN0005	TRANSISTOR (SI)	
	Q525	B1GBCFGN0005	TRANSISTOR (SI)	
	Q526	B1GBCFGN0005	TRANSISTOR (SI)	
	Q527	DRC9123J0L	TRANSISTOR (SI)	
	Q528	DSC9001R0L	TRANSISTOR (SI)	
	Q529	B1GBCFGN0005	TRANSISTOR (SI)	
	Q530	DSC9001R0L	TRANSISTOR (SI)	
	Q600	B1ADGE000012	TRANSISTOR (SI)	
	Q601	B1ADGE000012	TRANSISTOR (SI)	
	Q602	B1GBCFGN0005	TRANSISTOR (SI)	
	Q603	B1ADGE000012	TRANSISTOR (SI)	
	Q604	B1ADCF000020	TRANSISTOR (SI)	
	Q605	DRA9143Z0L	TRANSISTOR (SI)	
	Q607	DSC9001R0L	TRANSISTOR (SI)	
	Q608	B1ADGE000012	TRANSISTOR (SI)	
	Q609	B1ADGE000012	TRANSISTOR (SI)	
	Q610	B1GBCFGN0005	TRANSISTOR (SI)	

Safety	Ref. No.	Part No.	Part Name & Description	Remarks
	Q611	B1GBCFGN0005	TRANSISTOR (SI)	
	Q612	B1GBCFGN0005	TRANSISTOR (SI)	
	Q613	B1ADCF000020	TRANSISTOR (SI)	
	Q614	DRA9143Z0L	TRANSISTOR (SI)	
	Q650	B1ADCF000020	TRANSISTOR (SI)	
	Q651	DSC9001R0L	TRANSISTOR (SI)	
	Q702	B1GBCFGN0005	TRANSISTOR (SI)	
	Q703	DRA9143Z0L	TRANSISTOR (SI)	
	Q800	B1CHND000004	TRANSISTOR (SI)	
	Q801	B1GBCFGN0005	TRANSISTOR (SI)	
	Q802	B1CHND000004	TRANSISTOR (SI)	
	Q803	DRA9143Z0L	TRANSISTOR (SI)	
	Q804	DSC9001R0L	TRANSISTOR (SI)	
	Q805	DSC9001R0L	TRANSISTOR (SI)	
	Q806	B1GBCFGN0005	TRANSISTOR (SI)	
	Q807	B1CHQD000018	TRANSISTOR (SI)	
	Q808	B1CHQD000018	TRANSISTOR (SI)	
	Q809	B1ADCF000020	TRANSISTOR (SI)	
	Q810	DSC9001R0L	TRANSISTOR (SI)	
	Q812	B1GBCFGN0005	TRANSISTOR (SI)	
	Q813	B1CHQD000018	TRANSISTOR (SI)	
	Q814	B1ADCF000020	TRANSISTOR (SI)	
	Q815	B1GBCFGN0005	TRANSISTOR (SI)	
			(DIODES)	
	D100	DZ2W30000L	DIODE (SI)	
	D101	B0EDER000009	DIODE (SI)	
	D102	DA2J10100L	DIODE (SI)	
	D103	DZ2J056M0L	DIODE (SI)	
	D104	DZ2J056M0L	DIODE (SI)	
	D306	B0ZBZ0000146	DIODE (SI)	
	D600	DA2J10100L	DIODE (SI)	
	D601	DA2J10100L	DIODE (SI)	
	D801	DZ2W05600L	DIODE (SI)	S
	D803	DZ2W05600L	DIODE (SI)	S
	D804	B0JCN0000031	DIODE (SI)	
	D805	B0BC6R5A0541	DIODE (SI)	
	D806	PJVDJADAN202	DIODE (SI)	S
	D807	DA2J10100L	DIODE (SI)	
	DA300	B0ADEJ000025	DIODE (SI)	
	LED750	B3ABB0000331	DIODE (SI)	
			(BATTERY)	
	BAT300	BR2032/1HF1	BATTERY	S
			(CAPACITORS)	
	C100	ECUE1C103KBQ	0.01	S
	C101	ECUE1A104KBQ	0.1	S
	C102	ECUE1A104KBQ	0.1	S
⚠	C103	F1BAF330A048	33p	
⚠	C104	F1BAF330A048	33p	
	C105	EEE1HA010SR	1	
	C106	ECUE1A104KBQ	0.1	S
	C107	ECUE1A104KBQ	0.1	S
	C108	F1J2E121A023	0.00012	
	C109	F1J2E121A023	0.00012	
	C110	F1G1H272A571	0.0027	
	C111	ECUE1C103KBQ	0.01	S
	C112	ECUE1C103KBQ	0.01	S
	C113	F1J2E1030004	0.01	
	C114	F1G1H101A557	0.0001	
	C115	F0C2E1050004	1	
⚠	C116	F1BAF471A049	470p	
⚠	C117	F1BAF471A049	470p	
⚠	C119	F1BAF330A048	33p	
	C203	ECUE1C103KBQ	0.01	S
	C204	ECUE1A104KBQ	0.1	S
	C206	ECUE1C223KBQ	0.022	S
	C207	ECUE1A104KBQ	0.1	S
	C209	ECUE1A104KBQ	0.1	S
	C211	ECUE1A104KBQ	0.1	S
	C212	ECUE1C223KBQ	0.022	S
	C226	F1G0J105A007	10	
	C227	F1G0J105A007	10	
	C229	ECJ0EB1H392K	0.0039	
	C232	F1J0J2260004	220	

Safety	Ref. No.	Part No.	Part Name & Description	Remarks
	C300	ECUE1A104KBQ	0.1	S
	C301	ECUE1C103KBQ	0.01	S
	C302	ECUE1A104KBQ	0.1	S
	C303	ECUE1A104KBQ	0.1	S
	C304	ECUE1A104KBQ	0.1	S
	C305	ECUE1A104KBQ	0.1	S
	C306	ECUE1A104KBQ	0.1	S
	C307	ECUE1A104KBQ	0.1	S
	C308	FIG0J105A007	10	
	C309	FIG1A273A032	0.27	
	C310	FIG1H100A565	1p	
	C311	FIG1H180A565	18p	
	C312	ECUE1A104KBQ	0.1	S
	C313	FIG1H180A565	18p	
	C314	FIG1H180A565	18p	
	C319	FIG0J105A007	10	
	C322	ECUE1A104KBQ	0.1	S
	C325	FIG0J105A007	10	
	C326	ECUE1C103KBQ	0.01	S
	C327	ECUE1A104KBQ	0.1	S
	C328	FIG0J224A044	0.22	
	C329	FIG0J224A044	0.22	
	C330	FIG0J105A037	1	
	C331	FIG0J105A037	1	
	C340	ECUE1A104KBQ	0.1	S
	C341	ECUE1A104KBQ	0.1	S
	C342	ECUE1A104KBQ	0.1	S
	C343	ECUE1A104KBQ	0.1	S
	C344	ECUE1C103KBQ	0.01	S
	C351	FIG1H101A557	0.0001	
	C356	ECUE1A104KBQ	0.1	S
	C357	ECUE1A104KBQ	0.1	S
	C358	ECUE1A104KBQ	0.1	S
	C359	ECUE1A104KBQ	0.1	S
	C360	ECUE1A104KBQ	0.1	S
	C361	ECUE1A104KBQ	0.1	S
	C362	ECUE1A104KBQ	0.1	S
	C363	ECUE1A104KBQ	0.1	S
	C364	ECUE1A104KBQ	0.1	S
	C365	ECUE1H102KBQ	0.001	S
	C366	ECUE1A104KBQ	0.1	S
	C367	FIG0J105A007	10	
	C368	FIG0J105A007	10	
	C369	FIG0J105A007	10	
	C400	FIG0J105A037	1	
	C401	FIG0J105A037	1	
	C402	FIG0J105A037	1	
	C403	FIG0J105A037	1	
	C404	FIG0J105A037	1	
	C405	FIG0J105A037	1	
	C406	FIG0J105A037	1	
	C407	FIG0J105A037	1	
	C408	ECUE1A104KBQ	0.1	S
	C409	ECUE1A104KBQ	0.1	S
	C410	ECUE1A104KBQ	0.1	S
	C411	ECUE1A104KBQ	0.1	S
	C412	ECUE1A104KBQ	0.1	S
	C413	ECUE1A104KBQ	0.1	S
	C414	ECUE1A104KBQ	0.1	S
	C440	ECUE1A104KBQ	0.1	S
	C441	ECUE1A104KBQ	0.1	S
	C442	ECUE1A104KBQ	0.1	S
	C443	ECUE1A104KBQ	0.1	S
	C444	ECUE1A104KBQ	0.1	S
	C445	ECUE1A104KBQ	0.1	S
	C446	ECUE1A104KBQ	0.1	S
	C447	ECUE1A104KBQ	0.1	S
	C448	ECUE1A104KBQ	0.1	S
	C449	ECUE1A104KBQ	0.1	S
	C450	ECUE1A104KBQ	0.1	S
	C451	ECUE1A104KBQ	0.1	S
	C452	ECUE1A104KBQ	0.1	S
	C453	ECUE1A104KBQ	0.1	S

Safety	Ref. No.	Part No.	Part Name & Description	Remarks
	C454	ECUE1A104KBQ	0.1	S
	C455	ECUE1A104KBQ	0.1	S
	C456	ECUE1A104KBQ	0.1	S
	C457	ECUE1A104KBQ	0.1	S
	C458	ECUE1A104KBQ	0.1	S
	C459	ECUE1A104KBQ	0.1	S
	C460	ECUE1A104KBQ	0.1	S
	C461	ECUE1A104KBQ	0.1	S
	C462	ECUE1A104KBQ	0.1	S
	C463	ECUE1A104KBQ	0.1	S
	C464	ECUE1A104KBQ	0.1	S
	C465	ECUE1A104KBQ	0.1	S
	C466	ECUE1A104KBQ	0.1	S
	C467	ECUE1A104KBQ	0.1	S
	C468	ECUE1A104KBQ	0.1	S
	C469	ECUE1A104KBQ	0.1	S
	C470	ECUE1A104KBQ	0.1	S
	C471	ECUE1A104KBQ	0.1	S
	C472	ECUE1A104KBQ	0.1	S
	C473	ECUE1A104KBQ	0.1	S
	C474	ECUE1A104KBQ	0.1	S
	C475	ECUE1A104KBQ	0.1	S
	C476	ECUE1A104KBQ	0.1	S
	C477	ECUE1A104KBQ	0.1	S
	C478	ECUE1A104KBQ	0.1	S
	C479	ECUE1A104KBQ	0.1	S
	C485	FIG1H104A220	0.1	
	C486	FIG1H104A220	0.1	
	C487	FIG1H104A220	0.1	
	C488	FIG1H104A220	0.1	
	C489	FIG1H104A220	0.1	
	C490	FIG1H104A220	0.1	
	C491	FIG1H104A220	0.1	
	C492	FIG1H104A220	0.1	
	C493	FIG1H104A220	0.1	
	C494	FIG1H104A220	0.1	
	C495	FIG1H104A220	0.1	
	C496	FIG1H104A220	0.1	
	C497	FIG1H104A220	0.1	
	C498	FIG1H104A220	0.1	
	C499	FIG1H104A220	0.1	
	C500	ECUE1H8R0DCQ	8	
	C501	FIG1H220A565	22p	
	C503	ECUE1A104KBQ	0.1	S
	C504	ECUE1C103KBQ	0.01	S
	C505	ECUE1H181JCQ	180p	S
	C506	ECUE1H181JCQ	180p	S
	C507	ECUE1H102KBQ	0.001	S
	C508	ECJOEB1A473K	0.047	S
	C509	ECUE1H181JCQ	180p	S
	C510	ECUE1A104KBQ	0.1	S
	C511	ECUE1A104KBQ	0.1	S
	C512	ECUE1A104KBQ	0.1	S
	C513	ECUE1A104KBQ	0.1	S
	C514	ECUE1A104KBQ	0.1	S
	C515	ECUE1H181JCQ	180p	S
	C516	ECUE1H102KBQ	0.001	S
	C517	ECUE1A104KBQ	0.1	S
	C518	FIG1H104A220	0.1	
	C519	ECUE1A104KBQ	0.1	S
	C520	ECUE1H181JCQ	180p	S
	C522	ECUE1A104KBQ	0.1	S
	C523	ECUE1H181JCQ	180p	S
	C524	FIG1H220A565	22p	
	C525	ECUE1H102KBQ	0.001	S
	C526	ECUE1H102KBQ	0.001	S
	C527	ECUE1H102KBQ	0.001	S
	C528	ECUE1H102KBQ	0.001	S
	C529	ECUE1H102KBQ	0.001	S
	C530	ECUE1A104KBQ	0.1	S
	C531	FIG1A106A024	10	
	C532	ECUE1H181JCQ	180p	S
	C533	ECUE1A104KBQ	0.1	S

Safety	Ref. No.	Part No.	Part Name & Description	Remarks
	C534	ECUE1A104KBQ	0.1	S
	C535	ECUE1H102KBQ	0.001	S
	C536	ECUE1A104KBQ	0.1	S
	C537	ECUE1A104KBQ	0.1	S
	C538	F1G0J105A007	10	
	C539	ECUE1H102KBQ	0.001	S
	C540	ECUE1A104KBQ	0.1	S
	C541	ECUE1H102KBQ	0.001	S
	C542	ECUE1H181JCQ	180p	S
	C543	ECUE1A104KBQ	0.1	S
	C544	ECUE1C103KBQ	0.01	S
	C545	F1G0J105A007	10	
	C546	ECUE1C103KBQ	0.01	S
	C548	ECUE1H102KBQ	0.001	S
	C549	EEEEJA101WR	100	
	C551	ECUE1H102KBQ	0.001	S
	C552	F1H1H104A220	0.1	
	C553	ECUE1H102KBQ	0.001	S
	C554	ECUE1H102KBQ	0.001	S
	C555	ECUE1A104KBQ	0.1	S
	C556	ECUV0J474KBV	0.47	
	C557	ECUE1H181JCQ	180p	S
	C558	ECUE1H102KBQ	0.001	S
	C559	ECUE1H102KBQ	0.001	S
	C561	ECUE1H102KBQ	0.001	S
	C562	ECUE1H102KBQ	0.001	S
	C565	ECJ0EB1A473K	0.047	S
	C569	ECJ0EB1A473K	0.047	S
	C571	ECUE1A104KBQ	0.1	S
	C572	F1G0J105A007	10	
	C576	ECUE1A104KBQ	0.1	S
	C577	ECUE1H102KBQ	0.001	S
	C600	ECUE1H102KBQ	0.001	S
	C601	ECUE1H102KBQ	0.001	S
	C613	F2G1V1010021	100	
	C615	F1G1H101A557	0.0001	
	C618	F1G0J105A007	10	
	C619	ECUE1H102KBQ	0.001	S
	C650	ECUE1C103KBQ	0.01	S
	C652	F1G0J105A007	10	
	C654	ECUE1A104KBQ	0.1	S
	C655	ECUE1H103ZFO	0.01	S
	C656	ECUE1H103ZFO	0.01	S
	C657	ECUE1A104KBQ	0.1	S
	C700	ECUE1C103KBQ	0.01	S
	C701	ECUE1H102KBQ	0.001	S
	C702	ECUE1H102KBQ	0.001	S
	C709	ECUE1H222KBQ	0.0022	S
	C710	ECUE1H222KBQ	0.0022	S
	C711	ECUE1H222KBQ	0.0022	S
	C712	ECUE1H222KBQ	0.0022	S
	C751	ECUE1A104KBQ	0.1	S
	C752	F1J1C106A191	10	
	C753	ECUE1A104KBQ	0.1	S
	C754	ECUE1C103KBQ	0.01	S
	C755	ECUE1C103KBQ	0.01	S
	C756	ECUE1H070DCQ	7p	S
	C757	ECJ0EC1H120J	12p	S
	C758	ECUE1A104KBQ	0.1	S
	C759	ECUE1A104KBQ	0.1	S
	C760	ECUE1A104KBQ	0.1	S
	C761	ECUE1A104KBQ	0.1	S
	C762	F1J1C106A191	10	
	C763	ECUE1A104KBQ	0.1	S
	C764	ECUE1A104KBQ	0.1	S
	C765	ECUE1A104KBQ	0.1	S
	C766	ECUE1A104KBQ	0.1	S
	C767	ECUE1A104KBQ	0.1	S
	C768	F1G1H100A565	1p	
	C800	F1G0J105A007	10	
	C801	F1K1E1060004	10	
	C802	F1H1H104A220	0.1	
	C803	ECUE1A104KBQ	0.1	S

Safety	Ref. No.	Part No.	Part Name & Description	Remarks
	C804	F1G0J105A007	10	
	C805	F1G1E472A086	0.0047	
	C806	F1G1H100A565	1p	
	C807	F1K0J476A009	47	
	C808	F1K1E1060004	10	
	C809	F1H1H104A220	0.1	
	C810	ECUE1A104KBQ	0.1	S
	C811	F1H1H104A220	0.1	
	C813	F1G0J105A007	10	
	C814	F1G1E472A086	0.0047	
	C815	F2G1V4700028	47	
	C816	F1K0J476A009	47	
	C817	F1H1C105A118	1	
	C818	F1H1C105A118	1	
	C819	F1K1E1060004	10	
	C820	F1H1H104A220	0.1	
	C822	F1J1C475A059	4.7	
	C823	ECUE1H102KBQ	0.001	S
	C824	ECUE1H102KBQ	0.001	S
	C826	ECUE1H102KBQ	0.001	S
	C829	F1J1A106A024	10	
	C830	F1G0J105A007	10	
	C831	F1J1A106A024	10	
	C832	F1J1C475A059	4.7	
	C833	F1H1H104A220	0.1	
	C834	F2G1V4700028	47	
	C835	F1J1A106A024	10	
	C836	F1J1A106A024	10	
	C837	F1H1H104A748	0.1	
	C863	ECUE1H471KBQ	470p	S
			(CONNECTORS AND JACKS)	
	CN100	K2LB106B0053	JACK/SOCKET	
	CN101	K2LB106B0053	JACK/SOCKET	
	CN750	K2LC108B0112	JACK/SOCKET	
	CN201	K1KA02A00587	CONNECTOR, 2PIN	
	CN300	K1FY104B0015	CONNECTOR, 4PIN	
	CN500	K1KA09A00236	CONNECTOR, 9PIN	
	CN501	K1KA05A00364	CONNECTOR, 5PIN	
	CN503	K1KA04A00527	CONNECTOR, 4PIN	
	CN504	K1KA10A00412	CONNECTOR, 10PIN	
	CN505	K1KA07A00257	CONNECTOR, 7PIN	
	CN506	K1KA02A00587	CONNECTOR, 2PIN	
	CN507	K1KA06A00428	CONNECTOR, 6PIN	
	CN508	K1KA02A00745	CONNECTOR, 2PIN	
	CN509	K1KA06A00499	CONNECTOR, 6PIN	
	CN511	K1KA06A00428	CONNECTOR, 6PIN	
	CN513	K1MY12AA0238	CONNECTOR, 12PIN	
	CN515	K1KA08A00440	CONNECTOR, 8PIN	
	CN516	K1KA04AA0193	CONNECTOR, 4PIN	
	CN517	K1KA08A00440	CONNECTOR, 8PIN	
	CN518	K1KA08AA0193	CONNECTOR, 8PIN	
	CN519	K1KA03A00612	CONNECTOR, 3PIN	
	CN700	K1KA09A00204	CONNECTOR, 9PIN	
	CN800	K1KA03A00495	CONNECTOR, 3PIN	
			(COILS)	
	L104	PQLQR2BT	COIL	S
	L105	PQLQR2BT	COIL	S
	L106	PQLQR2BT	COIL	S
	L107	PQLQR2BT	COIL	S
	L108	PQLQR2BT	COIL	S
	L109	PQLQR2BT	COIL	S
	L110	G0B862C00003	COIL	
	L300	G1BYYYYC00026	COIL	
	L372	J0JCC00000278	COIL	
	L508	PFVFP2P221SG	COIL	S
	L511	PQLQR2KB113T	COIL	S
	L752	G1BYYYY00010	COIL	
	L753	G1BYYYY00010	COIL	
	L800	G1C4R7MA0445	COIL	
	L801	G1C2R2MA0395	COIL	
	L802	G1C4R7MA0445	COIL	
			(IC FILTERS)	
	L100	J0JCC0000002	CERAMIC FILTER	

Safety	Ref. No.	Part No.	Part Name & Description	Remarks
	L101	J0JCC0000002	CERAMIC FILTER	
	L102	J0JBC0000040	IC FILTER	
	L103	J0JBC0000040	IC FILTER	
	L210	J0JCC0000288	IC FILTER	
	L211	J0JCC0000288	IC FILTER	
	L214	J0JCC0000276	IC FILTER	
	L302	J0JCC0000308	IC FILTER	
	L303	J0JCC0000308	IC FILTER	
	L304	J0JAC0000059	IC FILTER	
	L344	J0JCC0000286	IC FILTER	
	L345	J0JCC0000286	IC FILTER	
	L346	J0JCC0000286	IC FILTER	
	L347	J0JCC0000286	IC FILTER	
	L348	J0JCC0000277	IC FILTER	
	L349	J0JCC0000277	IC FILTER	
	L350	J0JCC0000277	IC FILTER	
	L351	J0JCC0000277	IC FILTER	
	L352	J0JCC0000277	IC FILTER	
	L353	J0JCC0000277	IC FILTER	
	L354	J0JCC0000277	IC FILTER	
	L355	J0JCC0000277	IC FILTER	
	L356	J0JCC0000413	IC FILTER	
	L357	J0MAB0000144	IC FILTER	
	L358	J0JCC0000277	IC FILTER	
	L359	J0JCC0000277	IC FILTER	
	L360	J0JCC0000276	IC FILTER	
	L361	J0JCC0000275	IC FILTER	
	L362	J0JCC0000276	IC FILTER	
	L364	J0JCC0000274	IC FILTER	
	L365	J0JCC0000286	IC FILTER	
	L504	J0HAA0000002	IC FILTER	
	L506	J0JCC0000276	IC FILTER	
	L507	J0JCC0000276	IC FILTER	
	L509	J0JAC0000059	IC FILTER	
	L510	J0JCC0000276	IC FILTER	
	L750	J0JCC0000276	IC FILTER	
	L751	J0JCC0000251	IC FILTER	
	R559	J0JCC0000276	IC FILTER	
			(RESISTORS)	
	R100	D0GA473JA021	47k	
	R102	D0GB560JA057	56	
	R103	D0GB560JA057	56	
	R104	ERJ2RKF1004	1m	
	R105	ERJ12SF1071	1m	
	R106	ERJ6GEYJ515	5.1m	
	R107	ERJ6GEYJ515	5.1m	
	R108	ERJ12SF3651	3.65k	
	R109	D0GF156JA051	15m	
	R110	D0GF156JA051	15m	
	R111	D0GA151JA021	150	
	R112	ERJ8ENF5360	536	
	R113	ERJ12SF73R2	73.2	
	R114	ERJ12SF2491	2.49k	
	R115	D0GA104JA021	100k	
	R116	D0GA104JA021	100k	
	R117	ERDS1TJ223	22k	S
	R119	ERG1SJ120E	12	
	R121	D0GA103JA021	10k	
	R122	PQ4R18XJ100	10	S
	R200	D0YBR0000020	0	
	R204	D0YBR0000020	0	
	R205	D0YBR0000020	0	
	R206	D0GA473JA021	47k	
	R207	D0GA332JA015	3.3k	
	R212	D0GA472JA021	4.7k	
	R213	D0GA103JA021	10k	
	R215	D0GA105JA021	1m	
	R216	D0GA472JA021	4.7k	
	R227	D0GA102JA021	1k	
	R229	D0GA273JA015	27k	
	R233	PQ4R18XJ100	10	S
	R234	ERJ2GEYJ154	150k	S
	R235	D0GA124JA015	120k	

Safety	Ref. No.	Part No.	Part Name & Description	Remarks
	R302	D0GA103JA021	10k	
	R303	D0GA103JA021	10k	
	R304	ERJ2GEJ101	100	S
	R305	D0GA103JA021	10k	
	R306	D0GA102JA021	1k	
	R307	D0GA103JA021	10k	
	R309	ERJ2RKF3301	3.3k	
	R310	ERJ2RKF6801	6.8k	
	R311	ERJ2GE0R00	0	S
	R312	ERJ2GE0R00	0	S
	R313	ERJ2GE0R00	0	S
	R314	ERJ2GE0R00	0	S
	R315	D0GA103JA021	10k	
	R316	D0GA103JA021	10k	
	R317	D0GA470JA021	47	
	R318	D0GA470JA021	47	
	R319	D0GA104JA021	100k	
	R320	ERJ2RKF1212	12.1k	
	R321	D0GA103JA021	10k	
	R322	D0GA103JA021	10k	
	R323	D0GA103JA021	10k	
	R324	D0GA103JA021	10k	
	R325	D0GA103JA021	10k	
	R327	ERJ2GE0R00	0	S
	R329	ERJ2GE0R00	0	S
	R331	ERJ2GE0R00	0	S
	R332	ERJ2GE0R00	0	S
	R335	ERJ2GE0R00	0	S
	R338	D0GA103JA021	10k	
	R339	ERJ2GEJ823	82k	S
	R345	D0GA103JA021	10k	
	R346	D0GA152JA021	1.5k	
	R352	D0GA103JA021	10k	
	R354	D0GA103JA021	10k	
	R355	D0GA103JA021	10k	
	R356	ERJ3GEYJ6R8	6.8	
	R357	ERJ3GEYJ6R8	6.8	
	R360	D0GA103JA021	10k	
	R363	D0GA103JA021	10k	
	R365	D0GA103JA021	10k	
	R366	D0GA470JA021	47	
	R367	D0GA151JA021	150	
	R368	D0GA151JA021	150	
	R369	D0GA151JA021	150	
	R370	D0GA104JA021	100k	
	R371	D0GA103JA021	10k	
	R372	D0GA103JA021	10k	
	R373	D0GA103JA021	10k	
	R377	D0GA103JA021	10k	
	R379	D0GA470JA021	47	
	R382	ERJ2GE0R00	0	S
	R383	ERJ2GE0R00	0	S
	R384	ERJ2GEJ101	100	S
	R385	D0GA105JA021	1m	
	R386	D0GA151JA021	150	
	R387	D0GA470JA021	47	
	R388	ERJ2GEYJ683	68k	S
	R389	D0GA102JA021	1k	
	R391	D0GA103JA021	10k	
	R399	D0GA103JA021	10k	
	R400	D0GA470JA021	47	
	R401	D0GA680JA015	68	
	R402	D0GA470JA021	47	
	R403	D0GA470JA021	47	
	R404	D0GA470JA021	47	
	R405	D0GA470JA021	47	
	R406	D0GA470JA021	47	
	R407	D0GA470JA021	47	
	R408	D0GA470JA021	47	
	R409	D0GA560JA015	56	
	R410	D0GA680JA015	68	
	R411	D0GA680JA015	68	
	R412	D0GA470JA021	47	

Safety	Ref. No.	Part No.	Part Name & Description	Remarks
	R413	D0GA470JA021	47	
	R414	D0GA470JA021	47	
	R415	D0GA470JA021	47	
	R416	D0GA470JA021	47	
	R417	D0GA470JA021	47	
	R418	D0GA470JA021	47	
	R419	D0GA560JA015	56	
	R420	D0GA680JA015	68	
	R421	D0GA470JA021	47	
	R422	D0GA330JA015	33	
	R423	D0GA103JA021	10k	
	R424	D0GA103JA021	10k	
	R425	ERJ2GEJ820	82	S
	R450	D0GA103JA021	10k	
	R451	D0GA103JA021	10k	
	R495	D0YBR0000020	0	
	R496	D0YBR0000020	0	
	R497	D0YBR0000020	0	
	R498	D0YBR0000020	0	
	R500	D0GA220JA021	22	
	R501	ERJ2GEJ101	100	S
	R502	ERJ2GEJ101	100	S
	R503	ERJ2RKF1502	15k	
	R504	D0GA473JA021	47k	
	R505	ERJ2RKF3012	30.1k	
	R506	D0GA223JA015	22k	
	R507	D0GA221JA021	220	
	R508	D0GA330JA015	33	
	R509	D0GA102JA021	1k	
	R510	D0GA562JA021	5.6k	
	R511	D0GA105JA021	1m	
	R512	ERJ2GEJ563	56k	S
	R515	D0GA102JA021	1k	
	R516	ERJ2GEJ622X	6.2k	
	R517	D0GA103JA021	10k	
	R518	D0GA472JA021	4.7k	
	R519	D0GA103JA021	10k	
	R520	D0GA103JA021	10k	
	R521	D0GA470JA021	47	
	R522	ERJ3GEYJ6R8	6.8	
	R523	ERJ2GEJ563	56k	S
	R524	ERJ2GEOR00	0	S
	R525	ERJ2GEOR00	0	S
	R526	D0GA330JA015	33	
	R527	D0GA562JA021	5.6k	
	R528	D0GA330JA015	33	
	R529	ERJ2GEOR00	0	S
	R530	ERJ2GEJ471	470	S
	R531	D0GA330JA015	33	
	R533	D0GA473JA021	47k	
	R534	D0GA222JA021	2.2k	
	R535	D0GA473JA021	47k	
	R536	D0GA474JA021	470k	
	R537	D0GA473JA021	47k	
	R538	D0GA152JA021	1.5k	
	R539	D0GA182JA015	1.8k	
	R541	ERJ2GEYJ331	330	S
	R542	D0GA681JA021	680	
	R543	ERJ3GEYJ390	39	
	R544	ERJ2GEYJ331	330	S
	R545	D0GA330JA015	33	
	R546	D0GA681JA021	680	
	R547	D0GA330JA015	33	
	R548	D0GA330JA015	33	
	R549	D0GB560JA057	56	
	R550	ERJ2GEYJ331	330	S
	R551	D0GA473JA021	47k	
	R552	D0GA102JA021	1k	
	R553	D0GA181JA021	180	
	R554	D0GA681JA021	680	
	R555	D0GA472JA021	4.7k	
	R556	ERJ3GEYJ680	68	S
	R557	D0GA473JA021	47k	

Safety	Ref. No.	Part No.	Part Name & Description	Remarks
	R558	D0GA102JA021	1k	
	R560	D0GA181JA021	180	
	R561	D0GA102JA021	1k	
	R562	D0GA102JA021	1k	
	R563	ERJ2GEJ101	100	S
	R564	ERJ2RKF1802	18k	
	R566	ERJ2GEJ563	56k	S
	R567	D0GA103JA021	10k	
	R568	ERJ2RKF3902	39k	
	R569	D0GA473JA021	47k	
	R570	D0GA102JA021	1k	
	R571	ERJ2GEJ563	56k	S
	R575	ERJ2GEJ564	560k	
	R576	D0GA104JA021	100k	
	R577	D0GA472JA021	4.7k	
	R578	D0GA473JA021	47k	
	R579	ERJ2GEJ471	470	S
	R580	D0GA102JA021	1k	
	R581	ERJ2RKF2551	2.55k	
	R582	D0GA473JA021	47k	
	R583	D0GA104JA021	100k	
	R584	ERJ2RKF1502	15k	
	R585	D0GA562JA021	5.6k	
	R586	ERJ2GEJ563	56k	S
	R587	D0GA223JA015	22k	
	R588	D0GA223JA015	22k	
	R591	D0GA473JA021	47k	
	R592	D0GA473JA021	47k	
	R593	PQ4R10XJ332	3.3k	S
	R594	D0GA102JA021	1k	
	R595	D0GA562JA021	5.6k	
	R596	D0GA562JA021	5.6k	
	R598	D0GA562JA021	5.6k	
	R599	D0GA562JA021	5.6k	
	R600	ERJ12YJ680	68	
	R601	ERJ12YJ680	68	
	R602	D0GA473JA021	47k	
	R603	D0GA473JA021	47k	
	R604	D0GA472JA021	4.7k	
	R605	D0GB222JA057	2.2k	
	R607	D0GB222JA057	2.2k	
	R608	D0GA473JA021	47k	
	R609	PQ4R18XJ121	120	S
	R611	D0GA183JA015	18k	
	R612	D0GA333JA015	33k	
	R616	ERJ12YJ390H	39	S
	R619	D0GA103JA021	10k	
	R622	D0GA473JA021	47k	
	R623	ERJ2RKF1503	150k	
	R624	ERJ2RKF2202X	22k	
	R627	PQ4R18XJ472	4.7k	S
	R629	D0GA102JA021	1k	
	R630	ERJ2RKF1503	150k	
	R633	D0GA223JA015	22k	
	R634	D0GA562JA021	5.6k	
	R636	ERJ2GEYJ683	68k	S
	R637	D0GA103JA021	10k	
	R638	D0GA472JA021	4.7k	
	R641	D0GA562JA021	5.6k	
	R642	ERJ2GEJ563	56k	S
	R644	D0GA102JA021	1k	
	R646	ERJ2GEJ563	56k	S
	R647	D0GA562JA021	5.6k	
	R649	D0GA472JA021	4.7k	
	R650	D0GA472JA021	4.7k	
	R652	D0GA103JA021	10k	
	R655	ERJ2GEJ823	82k	S
	R656	D0GA473JA021	47k	
	R657	ERJ8GEYJ2R7	2.7	
	R658	ERJ8GEYJ2R7	2.7	
	R659	D0GA103JA021	10k	
	R660	D0GA183JA015	18k	
	R661	D0GA472JA021	4.7k	

Safety	Ref. No.	Part No.	Part Name & Description	Remarks
	R662	D0GA183JA015	18k	
	R663	D0GA472JA021	4.7k	
	R664	D0GA103JA021	10k	
	R665	D0GA473JA021	47k	
	R666	ERJ8RQFR56V	0.56	
	R667	ERJ8RQFR22	0.22	
	R669	ERJ8RQFR22	0.22	
	R670	ERJ8RQFR56V	0.56	
	R671	ERJ2GEYJ154	150k	S
	R672	ERJ2GEJ184	180k	S
	R673	D0GA473JA021	47k	
	R674	ERJ2GEJ101	100	S
	R683	D0GA103JA021	10k	
	R687	ERJ12YJ680	68	
	R688	ERJ12YJ680	68	
	R689	D0GA473JA021	47k	
	R690	D0GA473JA021	47k	
	R691	D0GB222JA057	2.2k	
	R692	D0GB222JA057	2.2k	
	R693	PQ4R18XJ121	120	S
	R694	D0GA472JA021	4.7k	
	R695	D0GA473JA021	47k	
	R696	D0GA183JA015	18k	
	R697	D0GA333JA015	33k	
	R701	ERJ2GEJ563	56k	S
	R702	ERJ2GEJ563	56k	S
	R705	D0GA562JA021	5.6k	
	R706	D0GA562JA021	5.6k	
	R750	J0JCC0000308	IC FILTER	
	R751	ERJ2RKF2491X	2.49k	
	R752	D0GA472JA021	4.7k	
	R755	D0GA472JA021	4.7k	
	R756	D0GA221JA021	220	
	R757	D0GA472JA021	4.7k	
	R758	D0GA472JA021	4.7k	
	R759	D0GA103JA021	10k	
	R767	D0GA220JA021	22	
	R771	D0GA472JA021	4.7k	
	R772	D0GA472JA021	4.7k	
	R773	D0GA472JA021	4.7k	
	R800	D0YBR0000020	0	
	R801	D0YBR0000020	0	
	R802	D0YBR0000020	0	
	R803	ERJ2RKF2212	22.1k	
	R804	ERJ2RKF2212	22.1k	
	R805	D0GB103JA057	10k	
	R806	ERJ2RKF7322	73.2k	
	R807	ERJ2GEJ512	5.1k	
	R808	ERJ2RKF1201	1.2k	
	R809	D0GA103JA021	10k	
	R810	D0YBR0000020	0	
	R811	ERJ2RKF1272	12.7k	
	R812	D0YBR0000020	0	
	R813	D0YBR0000020	0	
	R814	D0GA472JA021	4.7k	
	R815	D0GA103JA021	10k	
	R816	D0GA102JA021	1k	
	R817	D0GA103JA021	10k	
	R818	D0GA104JA021	100k	
	R819	D0GA102JA021	1k	
	R820	D0GA102JA021	1k	
	R821	D0GA273JA015	27k	
	R822	D0GA473JA021	47k	
	R823	D0YBR0000020	0	
	R825	D0GA273JA015	27k	
	R826	D0GA473JA021	47k	
	R828	ERJ2GEJ564	560k	
	R829	D0GA473JA021	47k	
	R830	D0GA474JA021	470k	
	R831	D0GA474JA021	470k	
	R832	D0GA474JA021	470k	
	R833	D0GA104JA021	100k	
	R834	D0GA104JA021	100k	

Safety	Ref. No.	Part No.	Part Name & Description	Remarks
	R835	D0GA103JA021	10k	
	R836	D0GA392JA015	3.9k	
	R837	D0GA472JA021	4.7k	
	R838	ERJ2GEJ471	470	S
	R839	D0GA104JA021	100k	
	R840	ERJ2RKF6341X	6.34k	
	R841	ERJ3GEYJ4R7	4.7	S
	R843	ERJ2RKF2200	220	
	R844	ERJ2RKF2200	220	
	R845	ERJ3GEYJ510	51	
	R846	ERJ2GEJ471	470	S
	R847	ERJ2GEJ471	470	S
	R851	D0GA103JA021	10k	
	R853	D0GA330JA015	33	
	R854	D0GA330JA015	33	
	L363	D0GA151JA021	150	
	L369	D0GA221JA021	220	
	L370	D0GA221JA021	220	
	L371	D0GA221JA021	220	
			(COMPONENTS PARTS)	
	RA305	EXB28V220JX	RESISTOR ARRAY	
	RA316	EXB28V470JX	RESISTOR ARRAY	
	RA321	EXB28V220JX	RESISTOR ARRAY	
	RA322	EXB28V220JX	RESISTOR ARRAY	
	RA323	EXB28V220JX	RESISTOR ARRAY	
	RA324	EXB28V220JX	RESISTOR ARRAY	
	RA400	EXB28V220JX	RESISTOR ARRAY	
	RA401	EXB28V220JX	RESISTOR ARRAY	
	RA402	EXB28V220JX	RESISTOR ARRAY	
	RA403	EXB28V220JX	RESISTOR ARRAY	
	RA404	EXB28V470JX	RESISTOR ARRAY	
	RA405	EXB28V470JX	RESISTOR ARRAY	
	RA406	EXB28V470JX	RESISTOR ARRAY	
	RA407	EXB28V220JX	RESISTOR ARRAY	
	RA408	EXB28V220JX	RESISTOR ARRAY	
	RA409	EXB28V220JX	RESISTOR ARRAY	
	RA410	EXB28V220JX	RESISTOR ARRAY	
	RA411	EXB28V470JX	RESISTOR ARRAY	
	RA412	EXB28V470JX	RESISTOR ARRAY	
	RA413	EXB28V470JX	RESISTOR ARRAY	
	RA414	EXB28V330	RESISTOR ARRAY	
	RA415	EXB28V330	RESISTOR ARRAY	
	RA416	EXB28V330	RESISTOR ARRAY	
	RA417	EXB28V330	RESISTOR ARRAY	
	RA418	EXB28V330	RESISTOR ARRAY	
	RA419	EXB28V330	RESISTOR ARRAY	
	RA420	EXB28V330	RESISTOR ARRAY	
	RA421	EXB28V330	RESISTOR ARRAY	
	RA422	EXB28V330	RESISTOR ARRAY	
	RA423	EXB28V330	RESISTOR ARRAY	
	RA424	EXB28V330	RESISTOR ARRAY	
	RA425	EXB28V103JX	RESISTOR ARRAY	
	RA426	EXB28V103JX	RESISTOR ARRAY	
	RA427	EXB28V103JX	RESISTOR ARRAY	
	RA428	EXB28V103JX	RESISTOR ARRAY	
	RA500	EXB28V470JX	RESISTOR ARRAY	
	RA501	EXB28V470JX	RESISTOR ARRAY	
	RA502	EXB28V470JX	RESISTOR ARRAY	
			(RELAY)	
	△	RLY100	K6B1CYY00005	RELAY
			(VARISTORS)	
	△	SA100	PFRZRA102P6T	VARISTOR (SURGE ABSORBER) S
	△	SA101	PFRZRA102P6T	VARISTOR (SURGE ABSORBER) S
		SA102	J0LY00000157	VARISTOR (SURGE ABSORBER)
			(FUSES)	
		F100	K5G102A00041	FUSE S
	△	F600	K5H202Y00003	FUSE
			(CRYSTAL OSCILLATOR)	
		X300	H0J240500074	CRYSTAL OSCILLATOR
		X301	H0J245500124	CRYSTAL OSCILLATOR
		X303	H0A327200186	CRYSTAL OSCILLATOR
		X500	H0J300500039	CRYSTAL OSCILLATOR
		X750	H0J250500097	CRYSTAL OSCILLATOR

18.2.2. Main Board (For KX-MB2270EU)

Safety	Ref. No.	Part No.	Part Name & Description	Remarks
	PCB1	PNWP1B2270EU	MAIN BOARD ASS'Y (RTL) (ICs)	
	IC100	C1CB00002689	IC	
	IC101	C1CB00002690	IC	
	IC201	C1CB00001769	IC	
	IC203	C1AB00002556	IC	
	IC300	C1ZBZ0004649	IC	
	IC301	C0EBY0000665	IC	
	IC302	C0ZBZ0001747	IC	
	IC303	C0DBGYY03947	IC	
	IC400	C3ABRY000078	IC	
	IC401	C3ABRY000078	IC	
	IC402	PNWI2270EU	IC (ROM)	
	IC403	C0JBAZ001466	IC	
	IC404	C0JBAZ001466	IC	
	IC405	C0JBAZ001539	IC	
	IC406	C0JBAZ001539	IC	
	IC407	C0JBAA000362	IC	
	IC500	C1ZBZ0003879	IC	
	IC502	AN44071A	IC	
	IC503	C0FBAY000092	IC	
	IC504	C0BBBA000024	IC	
	IC750	C1CB00003704	IC	
	IC800	C0DBAYY01433	IC	
	IC801	C0DBAYY01433	IC	
	IC802	C0DBAYY00932	IC	
	IC803	C0DBEYY00102	IC	
	IC850	C5ZBZ0000133	IC	
	IC851	C0ZBZ0001182	IC	
			(TRANSISTORS)	
	Q100	DSC710100L	TRANSISTOR (SI)	
	Q101	DSC710100L	TRANSISTOR (SI)	
	Q102	B1ABDP000005	TRANSISTOR (SI)	
	Q103	B1ABDP000005	TRANSISTOR (SI)	
	Q104	B1ADGP000008	TRANSISTOR (SI)	
	Q105	DRC9123J0L	TRANSISTOR (SI)	
	Q200	B1GBCFGN0005	TRANSISTOR (SI)	
	Q500	DSC9001R0L	TRANSISTOR (SI)	
	Q501	B1GBCFGN0005	TRANSISTOR (SI)	
	Q502	B1GBCFGN0005	TRANSISTOR (SI)	
	Q503	B1GBCFGN0005	TRANSISTOR (SI)	
	Q504	B1GBCFGN0005	TRANSISTOR (SI)	
	Q505	B1GBCFGN0005	TRANSISTOR (SI)	
	Q506	B1GBCFGN0005	TRANSISTOR (SI)	
	Q507	B1ABGE000014	TRANSISTOR (SI)	
	Q509	B1ADKE000002	TRANSISTOR (SI)	
	Q510	B1ABGE000014	TRANSISTOR (SI)	
	Q511	B1ABGE000014	TRANSISTOR (SI)	
	Q513	B1GBCFGN0005	TRANSISTOR (SI)	
	Q514	B1ABGE000011	TRANSISTOR (SI)	
	Q516	B1ABGE000011	TRANSISTOR (SI)	
	Q517	B1ABGE000011	TRANSISTOR (SI)	
	Q518	B1ADGE000012	TRANSISTOR (SI)	
	Q520	B1GBCFGN0005	TRANSISTOR (SI)	
	Q525	B1GBCFGN0005	TRANSISTOR (SI)	
	Q526	B1GBCFGN0005	TRANSISTOR (SI)	
	Q527	DRC9123J0L	TRANSISTOR (SI)	
	Q528	DSC9001R0L	TRANSISTOR (SI)	
	Q529	B1GBCFGN0005	TRANSISTOR (SI)	
	Q530	DSC9001R0L	TRANSISTOR (SI)	
	Q600	B1ADGE000012	TRANSISTOR (SI)	
	Q601	B1ADGE000012	TRANSISTOR (SI)	
	Q602	B1GBCFGN0005	TRANSISTOR (SI)	
	Q603	B1ADGE000012	TRANSISTOR (SI)	
	Q604	B1ADCF000020	TRANSISTOR (SI)	
	Q605	DRA9143Z0L	TRANSISTOR (SI)	
	Q607	DSC9001R0L	TRANSISTOR (SI)	
	Q608	B1ADGE000012	TRANSISTOR (SI)	
	Q609	B1ADGE000012	TRANSISTOR (SI)	
	Q610	B1GBCFGN0005	TRANSISTOR (SI)	

Safety	Ref. No.	Part No.	Part Name & Description	Remarks
	Q611	B1GBCFGN0005	TRANSISTOR (SI)	
	Q612	B1GBCFGN0005	TRANSISTOR (SI)	
	Q613	B1ADCF000020	TRANSISTOR (SI)	
	Q614	DRA9143Z0L	TRANSISTOR (SI)	
	Q650	B1ADCF000020	TRANSISTOR (SI)	
	Q651	DSC9001R0L	TRANSISTOR (SI)	
	Q702	B1GBCFGN0005	TRANSISTOR (SI)	
	Q703	DRA9143Z0L	TRANSISTOR (SI)	
	Q800	B1CHND000004	TRANSISTOR (SI)	
	Q801	B1GBCFGN0005	TRANSISTOR (SI)	
	Q802	B1CHND000004	TRANSISTOR (SI)	
	Q803	DRA9143Z0L	TRANSISTOR (SI)	
	Q804	DSC9001R0L	TRANSISTOR (SI)	
	Q805	DSC9001R0L	TRANSISTOR (SI)	
	Q806	B1GBCFGN0005	TRANSISTOR (SI)	
	Q807	B1CHQD000018	TRANSISTOR (SI)	
	Q808	B1CHQD000018	TRANSISTOR (SI)	
	Q809	B1ADCF000020	TRANSISTOR (SI)	
	Q810	DSC9001R0L	TRANSISTOR (SI)	
	Q812	B1GBCFGN0005	TRANSISTOR (SI)	
	Q813	B1CHQD000018	TRANSISTOR (SI)	
	Q814	B1ADCF000020	TRANSISTOR (SI)	
	Q815	B1GBCFGN0005	TRANSISTOR (SI)	
	Q850	B1GBCFGN0005	TRANSISTOR (SI)	
			(DIODES)	
	D100	DZ2W30000L	DIODE (SI)	
	D101	B0EDER000009	DIODE (SI)	
	D102	DA2J10100L	DIODE (SI)	
	D103	DZ2J056M0L	DIODE (SI)	
	D104	DZ2J056M0L	DIODE (SI)	
	D306	B0ZBZ0000146	DIODE (SI)	
	D600	DA2J10100L	DIODE (SI)	
	D601	DA2J10100L	DIODE (SI)	
	D801	DZ2W05600L	DIODE (SI)	S
	D803	DZ2W05600L	DIODE (SI)	S
	D804	B0JCND000031	DIODE (SI)	
	D805	B0BC6R5A0541	DIODE (SI)	
	D806	PJVDJADAN202	DIODE (SI)	S
	D807	DA2J10100L	DIODE (SI)	
	DA300	B0ADEJ000025	DIODE (SI)	
	LED750	B3ABB0000331	DIODE (SI)	
			(BATTERY)	
	BAT300	BR2032/1HF1	BATTERY	S
			(CAPACITORS)	
	C100	ECUE1C103KBQ	0.01	S
	C101	ECUE1A104KBQ	0.1	S
	C102	ECUE1A104KBQ	0.1	S
⚠	C103	F1BAF330A048	33p	
⚠	C104	F1BAF330A048	33p	
	C105	EEE1HA010SR	1	
	C106	ECUE1A104KBQ	0.1	S
	C107	ECUE1A104KBQ	0.1	S
	C108	F1J2E121A023	0.00012	
	C109	F1J2E121A023	0.00012	
	C110	ECUE1H272KBQ	0.0027	
	C111	ECUE1C103KBQ	0.01	S
	C112	ECUE1C103KBQ	0.01	S
	C113	F1J2E1030004	0.01	
	C114	F1G1H101A557	0.0001	
	C115	F0C2E1050004	1	
⚠	C116	F1BAF471A049	470p	
⚠	C117	F1BAF471A049	470p	
⚠	C119	F1BAF330A048	33p	
	C203	ECUE1C103KBQ	0.01	S
	C204	ECUE1A104KBQ	0.1	S
	C206	ECUE1C223KBQ	0.022	S
	C207	ECUE1A104KBQ	0.1	S
	C209	ECUE1A104KBQ	0.1	S
	C211	ECUE1A104KBQ	0.1	S
	C212	ECUE1C223KBQ	0.022	S
	C226	ECJ0EB0J105K	1	
	C227	ECJ0EB0J105K	1	
	C229	ECJ0EB1H392K	0.0039	

Safety	Ref. No.	Part No.	Part Name & Description	Remarks
	C232	FIJ0J2260004	220	
	C300	ECUE1A104KBQ	0.1	S
	C301	ECUE1C103KBQ	0.01	S
	C302	ECUE1A104KBQ	0.1	S
	C303	ECUE1A104KBQ	0.1	S
	C304	ECUE1A104KBQ	0.1	S
	C305	ECUE1A104KBQ	0.1	S
	C306	ECUE1A104KBQ	0.1	S
	C307	ECUE1A104KBQ	0.1	S
	C308	ECJ0EB0J105K	1	
	C309	ECJ0EB1A273K	0.027	
	C310	FIG1H100A565	1p	
	C311	FIG1H180A565	18p	
	C312	ECUE1A104KBQ	0.1	S
	C313	FIG1H180A565	18p	
	C314	FIG1H180A565	18p	
	C319	ECJ0EB0J105K	1	
	C322	ECUE1A104KBQ	0.1	S
	C325	ECJ0EB0J105K	1	
	C326	ECUE1C103KBQ	0.01	S
	C327	ECUE1A104KBQ	0.1	S
	C328	FIG0J224A044	0.22	
	C329	FIG0J224A044	0.22	
	C330	FIH0J105A037	1	
	C331	FIH0J105A037	1	
	C340	ECUE1A104KBQ	0.1	S
	C341	ECUE1A104KBQ	0.1	S
	C342	ECUE1A104KBQ	0.1	S
	C343	ECUE1A104KBQ	0.1	S
	C344	ECUE1C103KBQ	0.01	S
	C351	FIG1H101A557	0.0001	
	C356	ECUE1A104KBQ	0.1	S
	C357	ECUE1A104KBQ	0.1	S
	C358	ECUE1A104KBQ	0.1	S
	C359	ECUE1A104KBQ	0.1	S
	C360	ECUE1A104KBQ	0.1	S
	C361	ECUE1A104KBQ	0.1	S
	C362	ECUE1A104KBQ	0.1	S
	C363	ECUE1A104KBQ	0.1	S
	C364	ECUE1A104KBQ	0.1	S
	C365	ECUE1H102KBQ	0.001	S
	C366	ECUE1A104KBQ	0.1	S
	C367	ECJ0EB0J105K	1	
	C368	ECJ0EB0J105K	1	
	C369	ECJ0EB0J105K	1	
	C400	FIH0J105A037	1	
	C401	FIH0J105A037	1	
	C402	FIH0J105A037	1	
	C403	FIH0J105A037	1	
	C404	FIH0J105A037	1	
	C405	FIH0J105A037	1	
	C406	FIH0J105A037	1	
	C407	FIH0J105A037	1	
	C408	ECUE1A104KBQ	0.1	S
	C409	ECUE1A104KBQ	0.1	S
	C410	ECUE1A104KBQ	0.1	S
	C411	ECUE1A104KBQ	0.1	S
	C412	ECUE1A104KBQ	0.1	S
	C413	ECUE1A104KBQ	0.1	S
	C414	ECUE1A104KBQ	0.1	S
	C440	ECUE1A104KBQ	0.1	S
	C441	ECUE1A104KBQ	0.1	S
	C442	ECUE1A104KBQ	0.1	S
	C443	ECUE1A104KBQ	0.1	S
	C444	ECUE1A104KBQ	0.1	S
	C445	ECUE1A104KBQ	0.1	S
	C446	ECUE1A104KBQ	0.1	S
	C447	ECUE1A104KBQ	0.1	S
	C448	ECUE1A104KBQ	0.1	S
	C449	ECUE1A104KBQ	0.1	S
	C450	ECUE1A104KBQ	0.1	S
	C451	ECUE1A104KBQ	0.1	S
	C452	ECUE1A104KBQ	0.1	S

Safety	Ref. No.	Part No.	Part Name & Description	Remarks
	C453	ECUE1A104KBQ	0.1	S
	C454	ECUE1A104KBQ	0.1	S
	C455	ECUE1A104KBQ	0.1	S
	C456	ECUE1A104KBQ	0.1	S
	C457	ECUE1A104KBQ	0.1	S
	C458	ECUE1A104KBQ	0.1	S
	C459	ECUE1A104KBQ	0.1	S
	C460	ECUE1A104KBQ	0.1	S
	C461	ECUE1A104KBQ	0.1	S
	C462	ECUE1A104KBQ	0.1	S
	C463	ECUE1A104KBQ	0.1	S
	C464	ECUE1A104KBQ	0.1	S
	C465	ECUE1A104KBQ	0.1	S
	C466	ECUE1A104KBQ	0.1	S
	C467	ECUE1A104KBQ	0.1	S
	C468	ECUE1A104KBQ	0.1	S
	C469	ECUE1A104KBQ	0.1	S
	C470	ECUE1A104KBQ	0.1	S
	C471	ECUE1A104KBQ	0.1	S
	C472	ECUE1A104KBQ	0.1	S
	C473	ECUE1A104KBQ	0.1	S
	C474	ECUE1A104KBQ	0.1	S
	C475	ECUE1A104KBQ	0.1	S
	C476	ECUE1A104KBQ	0.1	S
	C477	ECUE1A104KBQ	0.1	S
	C478	ECUE1A104KBQ	0.1	S
	C479	ECUE1A104KBQ	0.1	S
	C485	FIH1H104A220	0.1	
	C486	FIH1H104A220	0.1	
	C487	FIH1H104A220	0.1	
	C488	FIH1H104A220	0.1	
	C489	FIH1H104A220	0.1	
	C490	FIH1H104A220	0.1	
	C491	FIH1H104A220	0.1	
	C492	FIH1H104A220	0.1	
	C493	FIH1H104A220	0.1	
	C494	FIH1H104A220	0.1	
	C495	FIH1H104A220	0.1	
	C496	FIH1H104A220	0.1	
	C497	FIH1H104A220	0.1	
	C498	FIH1H104A220	0.1	
	C499	FIH1H104A220	0.1	
	C500	ECUE1H8R0DCQ	8	
	C501	FIG1H220A565	22p	
	C503	ECUE1A104KBQ	0.1	S
	C504	ECUE1C103KBQ	0.01	S
	C505	ECUE1H181JCQ	180p	S
	C506	ECUE1H181JCQ	180p	S
	C507	ECUE1H102KBQ	0.001	S
	C508	ECJ0EB1A473K	0.047	S
	C509	ECUE1H181JCQ	180p	S
	C510	ECUE1A104KBQ	0.1	S
	C511	ECUE1A104KBQ	0.1	S
	C512	ECUE1A104KBQ	0.1	S
	C513	ECUE1A104KBQ	0.1	S
	C514	ECUE1A104KBQ	0.1	S
	C515	ECUE1H181JCQ	180p	S
	C516	ECUE1H102KBQ	0.001	S
	C517	ECUE1A104KBQ	0.1	S
	C518	FIH1H104A220	0.1	
	C519	ECUE1A104KBQ	0.1	S
	C520	ECUE1H181JCQ	180p	S
	C522	ECUE1A104KBQ	0.1	S
	C523	ECUE1H181JCQ	180p	S
	C524	FIG1H220A565	22p	
	C525	ECUE1H102KBQ	0.001	S
	C526	ECUE1H102KBQ	0.001	S
	C527	ECUE1H102KBQ	0.001	S
	C528	ECUE1H102KBQ	0.001	S
	C529	ECUE1H102KBQ	0.001	S
	C530	ECUE1A104KBQ	0.1	S
	C531	FIJ1A106A024	10	
	C532	ECUE1H181JCQ	180p	S

Safety	Ref. No.	Part No.	Part Name & Description	Remarks
	C533	ECUE1A104KBQ	0.1	S
	C534	ECUE1A104KBQ	0.1	S
	C535	ECUE1H102KBQ	0.001	S
	C536	ECUE1A104KBQ	0.1	S
	C537	ECUE1A104KBQ	0.1	S
	C538	ECJ0EB0J105K	1	
	C539	ECUE1H102KBQ	0.001	S
	C540	ECUE1A104KBQ	0.1	S
	C541	ECUE1H102KBQ	0.001	S
	C542	ECUE1H181JCQ	180p	S
	C543	ECUE1A104KBQ	0.1	S
	C544	ECUE1C103KBQ	0.01	S
	C545	ECJ0EB0J105K	1	
	C546	ECUE1C103KBQ	0.01	S
	C548	ECUE1H102KBQ	0.001	S
	C549	EEEE0JA101WR	100	
	C551	ECUE1H102KBQ	0.001	S
	C552	F1H1H104A220	0.1	
	C553	ECUE1H102KBQ	0.001	S
	C554	ECUE1H102KBQ	0.001	S
	C555	ECUE1A104KBQ	0.1	S
	C556	ECUV0J474KBV	0.47	
	C557	ECUE1H181JCQ	180p	S
	C558	ECUE1H102KBQ	0.001	S
	C559	ECUE1H102KBQ	0.001	S
	C561	ECUE1H102KBQ	0.001	S
	C562	ECUE1H102KBQ	0.001	S
	C565	ECJ0EB1A473K	0.047	S
	C569	ECJ0EB1A473K	0.047	S
	C571	ECUE1A104KBQ	0.1	S
	C572	ECJ0EB0J105K	1	
	C576	ECUE1A104KBQ	0.1	S
	C577	ECUE1H102KBQ	0.001	S
	C600	ECUE1H102KBQ	0.001	S
	C601	ECUE1H102KBQ	0.001	S
	C613	F2G1V1010021	100	
	C615	F1G1H101A557	0.0001	
	C618	ECJ0EB0J105K	1	
	C619	ECUE1H102KBQ	0.001	S
	C650	ECUE1C103KBQ	0.01	S
	C652	ECJ0EB0J105K	1	
	C654	ECUE1A104KBQ	0.1	S
	C655	ECUE1H103ZFQ	0.01	S
	C656	ECUE1H103ZFQ	0.01	S
	C657	ECUE1A104KBQ	0.1	S
	C700	ECUE1C103KBQ	0.01	S
	C701	ECUE1H102KBQ	0.001	S
	C702	ECUE1H102KBQ	0.001	S
	C709	ECUE1H222KBQ	0.0022	S
	C710	ECUE1H222KBQ	0.0022	S
	C711	ECUE1H222KBQ	0.0022	S
	C712	ECUE1H222KBQ	0.0022	S
	C751	ECUE1A104KBQ	0.1	S
	C752	F1J1C106A191	10	
	C753	ECUE1A104KBQ	0.1	S
	C754	ECUE1C103KBQ	0.01	S
	C755	ECUE1C103KBQ	0.01	S
	C756	ECUE1H070DCQ	7p	S
	C757	ECJ0EC1H120J	12p	S
	C758	ECUE1A104KBQ	0.1	S
	C759	ECUE1A104KBQ	0.1	S
	C760	ECUE1A104KBQ	0.1	S
	C761	ECUE1A104KBQ	0.1	S
	C762	F1J1C106A191	10	
	C763	ECUE1A104KBQ	0.1	S
	C764	ECUE1A104KBQ	0.1	S
	C765	ECUE1A104KBQ	0.1	S
	C766	ECUE1A104KBQ	0.1	S
	C767	ECUE1A104KBQ	0.1	S
	C768	F1G1H100A565	1p	
	C800	ECJ0EB0J105K	1	
	C801	F1K1E1060004	10	
	C802	F1H1H104A220	0.1	

Safety	Ref. No.	Part No.	Part Name & Description	Remarks
	C803	ECUE1A104KBQ	0.1	S
	C804	ECJ0EB0J105K	1	
	C805	F1G1E472A086	0.0047	
	C806	F1G1H100A565	1p	
	C807	F1K0J476A009	47	
	C808	F1K1E1060004	10	
	C809	F1H1H104A220	0.1	
	C810	ECUE1A104KBQ	0.1	S
	C811	F1H1H104A220	0.1	
	C813	ECJ0EB0J105K	1	
	C814	F1G1E472A086	0.0047	
	C815	F2G1V4700028	47	
	C816	F1K0J476A009	47	
	C817	ECUV1C105KBV	1	
	C818	ECUV1C105KBV	1	
	C819	F1K1E1060004	10	
	C820	F1H1H104A220	0.1	
	C822	F1J1C475A059	4.7	
	C823	ECUE1H102KBQ	0.001	S
	C824	ECUE1H102KBQ	0.001	S
	C826	ECUE1H102KBQ	0.001	S
	C829	F1J1A106A024	10	
	C830	ECJ0EB0J105K	1	
	C831	F1J1A106A024	10	
	C832	F1J1C475A059	4.7	
	C833	F1H1H104A220	0.1	
	C834	F2G1V4700028	47	
	C835	F1J1A106A024	10	
	C836	F1J1A106A024	10	
	C837	ECUV1H104KBV	0.1	
	C853	F1L0J476A017	47	
	C854	F1G1H101A557	0.0001	
	C855	F1J0J2260004	220	
	C856	F1J0J2260004	220	
	C857	ECUE1A104KBQ	0.1	S
	C858	F1J0J2260004	220	
	C859	ECUE1H102KBQ	0.001	S
	C860	ECUE1H102KBQ	0.001	S
	C861	F1G1H101A557	0.0001	
	C862	F1G1H101A557	0.0001	
	C863	ECUE1H471KBQ	470p	S
			(CONNECTORS AND JACKS)	
	CN100	K2LB106B0053	JACK/SOCKET	
	CN101	K2LB106B0053	JACK/SOCKET	
	CN201	K1KA02A00587	CONNECTOR, 2PIN	
	CN300	K1FY104B0015	CONNECTOR, 4PIN	
	CN500	K1KA09A00236	CONNECTOR, 9PIN	
	CN501	K1KA05A00364	CONNECTOR, 5PIN	
	CN503	K1KA04A00527	CONNECTOR, 4PIN	
	CN504	K1KA10A00412	CONNECTOR, 10PIN	
	CN505	K1KA07A00257	CONNECTOR, 7PIN	
	CN506	K1KA02A00587	CONNECTOR, 2PIN	
	CN507	K1KA06A00428	CONNECTOR, 6PIN	
	CN508	K1KA02A00745	CONNECTOR, 2PIN	
	CN509	K1KA06A00499	CONNECTOR, 6PIN	
	CN511	K1KA06A00428	CONNECTOR, 6PIN	
	CN513	K1MY12AA0238	CONNECTOR, 12PIN	
	CN515	K1KA08A00440	CONNECTOR, 8PIN	
	CN516	K1KA04AA0193	CONNECTOR, 4PIN	
	CN517	K1KA08A00440	CONNECTOR, 8PIN	
	CN518	K1KA08AA0193	CONNECTOR, 8PIN	
	CN519	K1KA03A00612	CONNECTOR, 3PIN	
	CN700	K1KA09A00204	CONNECTOR, 9PIN	
	CN750	K2LC108B0112	JACK/SOCKET	
	CN800	K1KA03A00495	CONNECTOR, 3PIN	
			(COILS)	
	L104	PQLQR2BT	COIL	S
	L105	PQLQR2BT	COIL	S
	L106	PQLQR2BT	COIL	S
	L107	PQLQR2BT	COIL	S
	L108	PQLQR2BT	COIL	S
	L109	PQLQR2BT	COIL	S
	L110	G0B862C00003	COIL	

Safety	Ref. No.	Part No.	Part Name & Description	Remarks
	L300	G1BYYC00026	COIL	
	L301	G1BYYC00026	COIL	
	L372	J0JCC0000278	COIL	
	L508	PFVFP2P221SG	COIL	s
	L511	PQLQR2KB113T	COIL	s
	L752	G1BYYYY00010	COIL	
	L753	G1BYYYY00010	COIL	
	L800	G1C4R7MA0445	COIL	
	L801	G1C2R2MA0395	COIL	
	L802	G1C4R7MA0445	COIL	
			(IC FILTERS)	
	L100	J0JCC0000002	IC FILTER	
	L101	J0JCC0000002	IC FILTER	
	L102	J0JBC0000040	IC FILTER	
	L103	J0JBC0000040	IC FILTER	
	L210	J0JCC0000288	IC FILTER	
	L211	J0JCC0000288	IC FILTER	
	L214	J0JCC0000276	IC FILTER	
	L302	J0JCC0000308	IC FILTER	
	L303	J0JCC0000308	IC FILTER	
	L304	J0JAC0000059	IC FILTER	
	L344	J0JCC0000286	IC FILTER	
	L345	J0JCC0000286	IC FILTER	
	L346	J0JCC0000286	IC FILTER	
	L347	J0JCC0000286	IC FILTER	
	L348	J0JCC0000277	IC FILTER	
	L349	J0JCC0000277	IC FILTER	
	L350	J0JCC0000277	IC FILTER	
	L351	J0JCC0000277	IC FILTER	
	L352	J0JCC0000277	IC FILTER	
	L353	J0JCC0000277	IC FILTER	
	L354	J0JCC0000277	IC FILTER	
	L355	J0JCC0000277	IC FILTER	
	L356	J0JCC0000413	IC FILTER	
	L357	J0MAB0000144	IC FILTER	
	L358	J0JCC0000277	IC FILTER	
	L359	J0JCC0000277	IC FILTER	
	L360	J0JCC0000276	IC FILTER	
	L361	J0JCC0000275	IC FILTER	
	L362	J0JCC0000276	IC FILTER	
	L364	J0JCC0000274	IC FILTER	
	L365	J0JCC0000286	IC FILTER	
	L504	J0HAB0000002	IC FILTER	
	L506	J0JCC0000276	IC FILTER	
	L507	J0JCC0000276	IC FILTER	
	L509	J0JAC0000059	IC FILTER	
	L510	J0JCC0000276	IC FILTER	
	L750	J0JCC0000276	IC FILTER	
	L751	J0JCC0000251	IC FILTER	
	R559	J0JCC0000276	IC FILTER	
	R750	J0JCC0000308	IC FILTER	
			(RESISTORS)	
	R100	D0GA473JA021	47k	
	R102	D0GB560JA057	56	
	R103	D0GB560JA057	56	
	R104	ERJ2RKF1004	1m	
	R105	ERJ12SF1071	1m	
	R106	ERJ6GEYJ515	5.1m	
	R107	ERJ6GEYJ515	5.1m	
	R108	ERJ12SF3651	3.65k	
	R109	D0GF156JA051	15m	
	R110	D0GF156JA051	15m	
	R111	D0GA151JA021	150	
	R112	ERJ8ENF5360	536	
	R113	ERJ12SF73R2	73.2	
	R114	ERJ12SF2491	2.49k	
	R115	D0GA104JA021	100k	
	R116	D0GA104JA021	100k	
	R117	ERDS1TJ223	22k	s
	R119	ERG1SJ120E	12	
	R121	D0GA103JA021	10k	
	R122	PQ4R18XJ100	10	s
	R200	D0YBR0000020	0	

Safety	Ref. No.	Part No.	Part Name & Description	Remarks
	R204	D0YBR0000020	0	
	R205	D0YBR0000020	0	
	R206	D0GA473JA021	47k	
	R207	D0GA332JA015	3.3k	
	R212	D0GA472JA021	4.7k	
	R213	D0GA103JA021	10k	
	R215	D0GA105JA021	1m	
	R216	D0GA472JA021	4.7k	
	R227	D0GA102JA021	1k	
	R229	D0GA273JA015	27k	
	R233	PQ4R18XJ100	10	s
	R234	ERJ2GEYJ154	150k	s
	R235	D0GA124JA015	120k	
	R302	D0GA103JA021	10k	
	R303	D0GA103JA021	10k	
	R304	ERJ2GEJ101	100	s
	R305	D0GA103JA021	10k	
	R306	D0GA102JA021	1k	
	R307	D0GA103JA021	10k	
	R309	ERJ2RKF3301	3.3k	
	R310	ERJ2RKF6801	6.8k	
	R311	ERJ2GE0R00	0	s
	R312	ERJ2GE0R00	0	s
	R313	ERJ2GE0R00	0	s
	R314	ERJ2GE0R00	0	s
	R315	D0GA103JA021	10k	
	R316	D0GA103JA021	10k	
	R317	D0GA470JA021	47	
	R318	D0GA470JA021	47	
	R319	D0GA104JA021	100k	
	R320	ERJ2RKF1212	12.1k	
	R321	D0GA103JA021	10k	
	R322	ERJ2RKF1212	12.1k	
	R323	D0GA103JA021	10k	
	R324	D0GA103JA021	10k	
	R325	D0GA103JA021	10k	
	R327	ERJ2GE0R00	0	s
	R329	ERJ2GE0R00	0	s
	R331	ERJ2GE0R00	0	s
	R332	ERJ2GE0R00	0	s
	R335	ERJ2GE0R00	0	s
	R338	D0GA103JA021	10k	
	R339	ERJ2GEJ823	82k	s
	R345	D0GA103JA021	10k	
	R346	D0GA152JA021	1.5k	
	R352	D0GA103JA021	10k	
	R354	D0GA103JA021	10k	
	R355	D0GA103JA021	10k	
	R356	ERJ3GEYJ6R8	6.8	
	R357	ERJ3GEYJ6R8	6.8	
	R360	D0GA103JA021	10k	
	R362	D0GA103JA021	10k	
	R365	D0GA103JA021	10k	
	R366	D0GA470JA021	47	
	R367	D0GA151JA021	150	
	R368	D0GA151JA021	150	
	R369	D0GA151JA021	150	
	R370	D0GA104JA021	100k	
	R371	D0GA103JA021	10k	
	R372	D0GA103JA021	10k	
	R373	D0GA103JA021	10k	
	R377	D0GA103JA021	10k	
	R379	D0GA470JA021	47	
	R382	ERJ2GE0R00	0	s
	R383	ERJ2GE0R00	0	s
	R384	ERJ2GEJ101	100	s
	R385	D0GA105JA021	1m	
	R386	D0GA151JA021	150	
	R387	D0GA470JA021	47	
	R388	ERJ2GEYJ683	68k	s
	R389	D0GA102JA021	1k	
	R391	D0GA103JA021	10k	
	R399	D0GA103JA021	10k	

Safety	Ref. No.	Part No.	Part Name & Description	Remarks
	R400	D0GA470JA021	47	
	R401	D0GA680JA015	68	
	R402	D0GA470JA021	47	
	R403	D0GA470JA021	47	
	R404	D0GA470JA021	47	
	R405	D0GA470JA021	47	
	R406	D0GA470JA021	47	
	R407	D0GA470JA021	47	
	R408	D0GA470JA021	47	
	R409	D0GA560JA015	56	
	R410	D0GA680JA015	68	
	R411	D0GA680JA015	68	
	R412	D0GA470JA021	47	
	R413	D0GA470JA021	47	
	R414	D0GA470JA021	47	
	R415	D0GA470JA021	47	
	R416	D0GA470JA021	47	
	R417	D0GA470JA021	47	
	R418	D0GA470JA021	47	
	R419	D0GA560JA015	56	
	R420	D0GA680JA015	68	
	R421	D0GA470JA021	47	
	R422	D0GA330JA015	33	
	R423	D0GA103JA021	10k	
	R424	D0GA103JA021	10k	
	R425	ERJ2GEJ820	82	S
	R450	D0GA103JA021	10k	
	R451	D0GA103JA021	10k	
	R495	D0YBR0000020	0	
	R496	D0YBR0000020	0	
	R497	D0YBR0000020	0	
	R498	D0YBR0000020	0	
	R500	D0GA220JA021	22	
	R501	ERJ2GEJ101	100	S
	R502	ERJ2GEJ101	100	S
	R503	ERJ2RKF1502	15k	
	R504	D0GA473JA021	47k	
	R505	ERJ2RKF3012	30.1k	
	R506	D0GA223JA015	22k	
	R507	D0GA221JA021	220	
	R508	D0GA330JA015	33	
	R509	D0GA102JA021	1k	
	R510	D0GA562JA021	5.6k	
	R511	D0GA105JA021	1m	
	R512	ERJ2GEJ563	56k	S
	R515	D0GA102JA021	1k	
	R516	ERJ2GEJ622X	6.2k	
	R517	D0GA103JA021	10k	
	R518	D0GA472JA021	4.7k	
	R519	D0GA103JA021	10k	
	R520	D0GA103JA021	10k	
	R521	D0GA470JA021	47	
	R522	ERJ3GEYJ6R8	6.8	
	R523	ERJ2GEJ563	56k	S
	R524	ERJ2GEOR00	0	S
	R525	ERJ2GEOR00	0	S
	R526	D0GA330JA015	33	
	R527	D0GA562JA021	5.6k	
	R528	D0GA330JA015	33	
	R529	ERJ2GEOR00	0	S
	R530	ERJ2GEJ471	470	S
	R531	D0GA330JA015	33	
	R533	D0GA473JA021	47k	
	R534	D0GA222JA021	2.2k	
	R535	D0GA473JA021	47k	
	R536	D0GA474JA021	470k	
	R537	D0GA473JA021	47k	
	R538	D0GA152JA021	1.5k	
	R539	D0GA182JA015	1.8k	
	R541	ERJ2GEYJ331	330	S
	R542	D0GA681JA021	680	
	R543	ERJ3GEYJ390	39	
	R544	ERJ2GEYJ331	330	S

Safety	Ref. No.	Part No.	Part Name & Description	Remarks
	R545	D0GA330JA015	33	
	R546	D0GA681JA021	680	
	R547	D0GA330JA015	33	
	R548	D0GA330JA015	33	
	R549	D0GB560JA057	56	
	R550	ERJ2GEYJ331	330	S
	R551	D0GA473JA021	47k	
	R552	D0GA102JA021	1k	
	R553	D0GA181JA021	180	
	R554	D0GA681JA021	680	
	R555	D0GA472JA021	4.7k	
	R556	ERJ3GEYJ680	68	S
	R557	D0GA473JA021	47k	
	R558	D0GA102JA021	1k	
	R560	D0GA181JA021	180	
	R561	D0GA102JA021	1k	
	R562	D0GA102JA021	1k	
	R563	ERJ2GEJ101	100	S
	R564	ERJ2RKF1802	18k	
	R566	ERJ2GEJ563	56k	S
	R567	D0GA103JA021	10k	
	R568	ERJ2RKF3902	39k	
	R569	D0GA473JA021	47k	
	R570	D0GA102JA021	1k	
	R571	ERJ2GEJ563	56k	S
	R575	ERJ2GEJ564	560k	
	R576	D0GA104JA021	100k	
	R577	D0GA472JA021	4.7k	
	R578	D0GA473JA021	47k	
	R579	ERJ2GEJ471	470	S
	R580	D0GA102JA021	1k	
	R581	ERJ2RKF2551	2.55k	
	R582	D0GA473JA021	47k	
	R583	D0GA104JA021	100k	
	R584	ERJ2RKF1502	15k	
	R585	D0GA562JA021	5.6k	
	R586	ERJ2GEJ563	56k	S
	R587	D0GA223JA015	22k	
	R588	D0GA223JA015	22k	
	R591	D0GA473JA021	47k	
	R592	D0GA473JA021	47k	
	R593	PQ4R10XJ332	3.3k	S
	R594	D0GA102JA021	1k	
	R595	D0GA562JA021	5.6k	
	R596	D0GA562JA021	5.6k	
	R598	D0GA562JA021	5.6k	
	R599	D0GA562JA021	5.6k	
	R600	ERJ12YJ680	68	
	R601	ERJ12YJ680	68	
	R602	D0GA473JA021	47k	
	R603	D0GA473JA021	47k	
	R604	D0GA472JA021	4.7k	
	R605	D0GB222JA057	2.2k	
	R607	D0GB222JA057	2.2k	
	R608	D0GA473JA021	47k	
	R609	PQ4R18XJ121	120	S
	R611	D0GA183JA015	18k	
	R612	D0GA333JA015	33k	
	R616	ERJ12YJ390H	39	S
	R619	D0GA103JA021	10k	
	R622	D0GA473JA021	47k	
	R623	ERJ2RKF1503	150k	
	R624	ERJ2RKF2202X	22k	
	R627	PQ4R18XJ472	4.7k	S
	R629	D0GA102JA021	1k	
	R630	ERJ2RKF1503	150k	
	R633	D0GA223JA015	22k	
	R634	D0GA562JA021	5.6k	
	R636	ERJ2GEYJ683	68k	S
	R637	D0GA103JA021	10k	
	R638	D0GA472JA021	4.7k	
	R641	D0GA562JA021	5.6k	
	R642	ERJ2GEJ563	56k	S

Safety	Ref. No.	Part No.	Part Name & Description	Remarks
	R644	D0GA102JA021	1k	
	R646	ERJ2GEJ563	56k	S
	R647	D0GA562JA021	5.6k	
	R649	D0GA472JA021	4.7k	
	R650	D0GA472JA021	4.7k	
	R652	D0GA103JA021	10k	
	R655	ERJ2GEJ823	82k	S
	R656	D0GA473JA021	47k	
	R657	ERJ8GEYJ2R7	2.7	
	R658	ERJ8GEYJ2R7	2.7	
	R659	D0GA103JA021	10k	
	R660	D0GA183JA015	18k	
	R661	D0GA472JA021	4.7k	
	R662	D0GA183JA015	18k	
	R663	D0GA472JA021	4.7k	
	R664	D0GA103JA021	10k	
	R665	D0GA473JA021	47k	
	R666	ERJ8RQFR56V	0.56	
	R667	ERJ8RQFR22	0.22	
	R669	ERJ8RQFR22	0.22	
	R670	ERJ8RQFR56V	0.56	
	R671	ERJ2GEYJ154	150k	S
	R672	ERJ2GEJ184	180k	S
	R673	D0GA473JA021	47k	
	R674	ERJ2GEJ101	100	S
	R683	D0GA103JA021	10k	
	R687	ERJ12YJ680	68	
	R688	ERJ12YJ680	68	
	R689	D0GA473JA021	47k	
	R690	D0GA473JA021	47k	
	R691	D0GB222JA057	2.2k	
	R692	D0GB222JA057	2.2k	
	R693	PQ4R18XJ121	120	S
	R694	D0GA472JA021	4.7k	
	R695	D0GA473JA021	47k	
	R696	D0GA183JA015	18k	
	R697	D0GA333JA015	33k	
	R701	ERJ2GEJ563	56k	S
	R702	ERJ2GEJ563	56k	S
	R705	D0GA562JA021	5.6k	
	R706	D0GA562JA021	5.6k	
	R751	ERJ2RKF2491X	2.49k	
	R752	D0GA472JA021	4.7k	
	R755	D0GA472JA021	4.7k	
	R756	D0GA221JA021	220	
	R757	D0GA472JA021	4.7k	
	R758	D0GA472JA021	4.7k	
	R759	D0GA103JA021	10k	
	R767	D0GA220JA021	22	
	R771	D0GA472JA021	4.7k	
	R772	D0GA472JA021	4.7k	
	R773	D0GA472JA021	4.7k	
	R800	D0YBR0000020	0	
	R801	D0YBR0000020	0	
	R802	D0YBR0000020	0	
	R803	ERJ2RKF2212	22.1k	
	R804	ERJ2RKF2212	22.1k	
	R805	D0GB103JA057	10k	
	R806	ERJ2RKF7322	73.2k	
	R807	ERJ2GEJ512	5.1k	
	R808	ERJ2RKF1201	1.2k	
	R809	D0GA103JA021	10k	
	R810	D0YBR0000020	0	
	R811	ERJ2RKF1272	12.7k	
	R812	D0YBR0000020	0	
	R813	D0YBR0000020	0	
	R814	D0GA472JA021	4.7k	
	R815	D0GA103JA021	10k	
	R816	D0GA102JA021	1k	
	R817	D0GA103JA021	10k	
	R818	D0GA104JA021	100k	
	R819	D0GA102JA021	1k	
	R820	D0GA102JA021	1k	

Safety	Ref. No.	Part No.	Part Name & Description	Remarks
	R821	D0GA273JA015	27k	
	R822	D0GA473JA021	47k	
	R823	D0YBR0000020	0	
	R825	D0GA273JA015	27k	
	R826	D0GA473JA021	47k	
	R828	ERJ2GEJ564	560k	
	R829	D0GA473JA021	47k	
	R830	D0GA474JA021	470k	
	R831	D0GA474JA021	470k	
	R832	D0GA474JA021	470k	
	R833	D0GA104JA021	100k	
	R834	D0GA104JA021	100k	
	R835	D0GA103JA021	10k	
	R836	D0GA392JA015	3.9k	
	R837	D0GA472JA021	4.7k	
	R838	ERJ2GEJ471	470	S
	R839	D0GA104JA021	100k	
	R840	ERJ2RKF6341X	6.34k	
	R841	ERJ3GEYJ4R7	4.7	S
	R843	ERJ2RKF2200	220	
	R844	ERJ2RKF2200	220	
	R845	D0GB510JA057	51	
	R846	ERJ2GEJ471	470	S
	R847	ERJ2GEJ471	470	S
	R851	D0GA103JA021	10k	
	R853	D0GA330JA015	33	
	R854	D0GA330JA015	33	
	L363	D0GA151JA021	150	
	L369	D0GA221JA021	220	
	L370	D0GA221JA021	220	
	L371	D0GA221JA021	220	
			(COMPONENTS PARTS)	
	RA305	EXB28V220JX	RESISTOR ARRAY	
	RA316	EXB28V470JX	RESISTOR ARRAY	
	RA321	EXB28V220JX	RESISTOR ARRAY	
	RA322	EXB28V220JX	RESISTOR ARRAY	
	RA323	EXB28V220JX	RESISTOR ARRAY	
	RA324	EXB28V220JX	RESISTOR ARRAY	
	RA400	EXB28V220JX	RESISTOR ARRAY	
	RA401	EXB28V220JX	RESISTOR ARRAY	
	RA402	EXB28V220JX	RESISTOR ARRAY	
	RA403	EXB28V220JX	RESISTOR ARRAY	
	RA404	EXB28V470JX	RESISTOR ARRAY	
	RA405	EXB28V470JX	RESISTOR ARRAY	
	RA406	EXB28V470JX	RESISTOR ARRAY	
	RA407	EXB28V220JX	RESISTOR ARRAY	
	RA408	EXB28V220JX	RESISTOR ARRAY	
	RA409	EXB28V220JX	RESISTOR ARRAY	
	RA410	EXB28V220JX	RESISTOR ARRAY	
	RA411	EXB28V470JX	RESISTOR ARRAY	
	RA412	EXB28V470JX	RESISTOR ARRAY	
	RA413	EXB28V470JX	RESISTOR ARRAY	
	RA414	EXB28V330	RESISTOR ARRAY	
	RA415	EXB28V330	RESISTOR ARRAY	
	RA416	EXB28V330	RESISTOR ARRAY	
	RA417	EXB28V330	RESISTOR ARRAY	
	RA418	EXB28V330	RESISTOR ARRAY	
	RA419	EXB28V330	RESISTOR ARRAY	
	RA420	EXB28V330	RESISTOR ARRAY	
	RA421	EXB28V330	RESISTOR ARRAY	
	RA422	EXB28V330	RESISTOR ARRAY	
	RA423	EXB28V330	RESISTOR ARRAY	
	RA424	EXB28V330	RESISTOR ARRAY	
	RA425	EXB28V103JX	RESISTOR ARRAY	
	RA426	EXB28V103JX	RESISTOR ARRAY	
	RA427	EXB28V103JX	RESISTOR ARRAY	
	RA428	EXB28V103JX	RESISTOR ARRAY	
	RA500	EXB28V470JX	RESISTOR ARRAY	
	RA501	EXB28V470JX	RESISTOR ARRAY	
	RA502	EXB28V470JX	RESISTOR ARRAY	
			(RELAY)	
	△	RLY100	K6B1CYY00005	RELAY

Safety	Ref. No.	Part No.	Part Name & Description	Remarks
			(VARISTORS)	
△	SA100	PFRZRA102P6T	VARISTOR (SURGE ABSORBER)	S
△	SA101	PFRZRA102P6T	VARISTOR (SURGE ABSORBER)	S
	SA102	J0LY00000157	VARISTOR (SURGE ABSORBER)	
			(FUSES)	
	F100	K5G102A00041	FUSE	S
△	F600	K5H202Y00003	FUSE	
			(CRYSTAL OSCILLATORS)	
	X300	H0J240500074	CRYSTAL OSCILLATOR	
	X301	H0J245500124	CRYSTAL OSCILLATOR	
	X303	H0A327200186	CRYSTAL OSCILLATOR	
	X500	H0J300500039	CRYSTAL OSCILLATOR	
	X750	H0J250500097	CRYSTAL OSCILLATOR	

18.2.3. Main Board (For KX-MB2515EU)

Safety	Ref. No.	Part No.	Part Name & Description	Remarks
	PCB1	PNWP1B2515EU	MAIN BOARD ASS'Y (RTL)	
			(ICs)	
	IC300	C1ZBZ0004649	IC	
	IC301	C0EBY0000665	IC	
	IC302	C0ZBZ0001747	IC	
	IC303	C0DBGY03947	IC	
	IC304	C0DBZY00592	IC	
	IC400	C3ABRY000078	IC	
	IC401	C3ABRY000078	IC	
	IC402	PNWI2515EU	IC (ROM)	
	IC403	C0JBAZ001466	IC	
	IC404	C0JBAZ001466	IC	
	IC405	C0JBAZ001539	IC	
	IC406	C0JBAZ001539	IC	
	IC407	C0JBAA000362	IC	
	IC500	C1ZBZ0003879	IC	
	IC502	AN44071A	IC	
	IC503	C0FBAY000092	IC	
	IC504	C0BBBA000024	IC	
	IC750	C1CB00003704	IC	
	IC800	C0DBAY01433	IC	
	IC801	C0DBAY01433	IC	
	IC802	C0DBAY00932	IC	
	IC803	C0DBEY00102	IC	
			(TRANSISTORS)	
	Q500	DSC9001R0L	TRANSISTOR (SI)	
	Q501	B1GBCFGN0005	TRANSISTOR (SI)	
	Q502	B1GBCFGN0005	TRANSISTOR (SI)	
	Q503	B1GBCFGN0005	TRANSISTOR (SI)	
	Q504	B1GBCFGN0005	TRANSISTOR (SI)	
	Q505	B1GBCFGN0005	TRANSISTOR (SI)	
	Q506	B1GBCFGN0005	TRANSISTOR (SI)	
	Q507	B1ABGE000014	TRANSISTOR (SI)	
	Q508	B1ADKE000002	TRANSISTOR (SI)	
	Q509	B1ADKE000002	TRANSISTOR (SI)	
	Q510	B1ABGE000014	TRANSISTOR (SI)	
	Q511	B1ABGE000014	TRANSISTOR (SI)	
	Q512	B1GBCFGN0005	TRANSISTOR (SI)	
	Q513	B1GBCFGN0005	TRANSISTOR (SI)	
	Q514	B1ABGE000011	TRANSISTOR (SI)	
	Q516	B1ABGE000011	TRANSISTOR (SI)	
	Q517	B1ABGE000011	TRANSISTOR (SI)	
	Q518	B1ADGE000012	TRANSISTOR (SI)	
	Q520	B1GBCFGN0005	TRANSISTOR (SI)	
	Q525	B1GBCFGN0005	TRANSISTOR (SI)	
	Q526	B1GBCFGN0005	TRANSISTOR (SI)	
	Q527	DRC9123J0L	TRANSISTOR (SI)	
	Q528	DSC9001R0L	TRANSISTOR (SI)	
	Q529	B1GBCFGN0005	TRANSISTOR (SI)	
	Q530	DSC9001R0L	TRANSISTOR (SI)	
	Q600	B1ADGE000012	TRANSISTOR (SI)	
	Q601	B1ADGE000012	TRANSISTOR (SI)	
	Q602	B1GBCFGN0005	TRANSISTOR (SI)	
	Q603	B1ADGE000012	TRANSISTOR (SI)	

Safety	Ref. No.	Part No.	Part Name & Description	Remarks
	Q604	B1ADCF000020	TRANSISTOR (SI)	
	Q605	DRA9143Z0L	TRANSISTOR (SI)	
	Q607	DSC9001R0L	TRANSISTOR (SI)	
	Q608	B1ADGE000012	TRANSISTOR (SI)	
	Q609	B1ADGE000012	TRANSISTOR (SI)	
	Q610	B1GBCFGN0005	TRANSISTOR (SI)	
	Q611	B1GBCFGN0005	TRANSISTOR (SI)	
	Q612	B1GBCFGN0005	TRANSISTOR (SI)	
	Q613	B1ADCF000020	TRANSISTOR (SI)	
	Q614	DRA9143Z0L	TRANSISTOR (SI)	
	Q650	B1ADCF000020	TRANSISTOR (SI)	
	Q651	DSC9001R0L	TRANSISTOR (SI)	
	Q700	B1ABGE000014	TRANSISTOR (SI)	
	Q701	B1ABGE000014	TRANSISTOR (SI)	
	Q702	B1GBCFGN0005	TRANSISTOR (SI)	
	Q703	DRA9143Z0L	TRANSISTOR (SI)	
	Q800	B1CHND000004	TRANSISTOR (SI)	
	Q801	B1GBCFGN0005	TRANSISTOR (SI)	
	Q802	B1CHND000004	TRANSISTOR (SI)	
	Q803	DRA9143Z0L	TRANSISTOR (SI)	
	Q804	DSC9001R0L	TRANSISTOR (SI)	
	Q805	DSC9001R0L	TRANSISTOR (SI)	
	Q806	B1GBCFGN0005	TRANSISTOR (SI)	
	Q807	B1CHQD000018	TRANSISTOR (SI)	
	Q808	B1CHQD000018	TRANSISTOR (SI)	
	Q809	B1ADCF000020	TRANSISTOR (SI)	
	Q810	DSC9001R0L	TRANSISTOR (SI)	
	Q812	B1GBCFGN0005	TRANSISTOR (SI)	
	Q813	B1CHQD000018	TRANSISTOR (SI)	
	Q814	B1ADCF000020	TRANSISTOR (SI)	
	Q815	B1GBCFGN0005	TRANSISTOR (SI)	
			(DIODES)	
	D301	DD2S06200L	DIODE (SI)	
	D302	DD2S06200L	DIODE (SI)	
	D306	B0ZBZ0000146	DIODE (SI)	
	D600	DA2J10100L	DIODE (SI)	
	D601	DA2J10100L	DIODE (SI)	
	D801	DZ2W05600L	DIODE (SI)	S
	D803	DZ2W05600L	DIODE (SI)	S
	D804	B0JCND000031	DIODE (SI)	
	D805	B0BC6R5A0541	DIODE (SI)	
	D806	PJVDJADAN202	DIODE (SI)	S
	D807	DA2J10100L	DIODE (SI)	
	DA300	B0ADEJ000025	DIODE (SI)	
	LED750	B3ABB0000331	DIODE (SI)	
			(BATTERY)	
	BAT300	BR2032/1HF1	BATTERY	S
			(CAPACITORS)	
	C300	ECUE1A104KBQ	0.1	S
	C301	ECUE1C103KBQ	0.01	S
	C302	ECUE1A104KBQ	0.1	S
	C303	ECUE1A104KBQ	0.1	S
	C304	ECUE1A104KBQ	0.1	S
	C305	ECUE1A104KBQ	0.1	S
	C306	ECUE1A104KBQ	0.1	S
	C307	ECUE1A104KBQ	0.1	S
	C308	F1G0J105A007	10	
	C309	F1G1A273A032	0.27	
	C310	F1G1H100A565	1p	
	C311	F1G1H180A565	18p	
	C312	ECUE1A104KBQ	0.1	S
	C313	F1G1H180A565	18p	
	C314	F1G1H180A565	18p	
	C319	F1G0J105A007	10	
	C322	ECUE1A104KBQ	0.1	S
	C325	F1G0J105A007	10	
	C326	ECUE1C103KBQ	0.01	S
	C327	ECUE1A104KBQ	0.1	S
	C328	F1G0J224A044	0.22	
	C329	F1G0J224A044	0.22	
	C330	F1H0J105A037	1	
	C331	F1H0J105A037	1	
	C340	ECUE1A104KBQ	0.1	S

Safety	Ref. No.	Part No.	Part Name & Description	Remarks
	C341	ECUE1A104KBQ	0.1	S
	C342	ECUE1A104KBQ	0.1	S
	C343	ECUE1A104KBQ	0.1	S
	C344	ECUE1C103KBQ	0.01	S
	C351	FIG1H101A557	0.0001	
	C356	ECUE1A104KBQ	0.1	S
	C357	ECUE1A104KBQ	0.1	S
	C358	ECUE1A104KBQ	0.1	S
	C359	ECUE1A104KBQ	0.1	S
	C360	ECUE1A104KBQ	0.1	S
	C361	ECUE1A104KBQ	0.1	S
	C362	ECUE1A104KBQ	0.1	S
	C363	ECUE1A104KBQ	0.1	S
	C364	ECUE1A104KBQ	0.1	S
	C365	ECUE1H102KBQ	0.001	S
	C366	ECUE1A104KBQ	0.1	S
	C367	FIG0J105A007	10	
	C368	FIG0J105A007	10	
	C369	FIG0J105A007	10	
	C370	FIH1A105A025	1	
	C371	FIH0J1060006	10	
	C400	FIH0J105A037	1	
	C401	FIH0J105A037	1	
	C402	FIH0J105A037	1	
	C403	FIH0J105A037	1	
	C404	FIH0J105A037	1	
	C405	FIH0J105A037	1	
	C406	FIH0J105A037	1	
	C407	FIH0J105A037	1	
	C408	ECUE1A104KBQ	0.1	S
	C409	ECUE1A104KBQ	0.1	S
	C410	ECUE1A104KBQ	0.1	S
	C411	ECUE1A104KBQ	0.1	S
	C412	ECUE1A104KBQ	0.1	S
	C413	ECUE1A104KBQ	0.1	S
	C414	ECUE1A104KBQ	0.1	S
	C440	ECUE1A104KBQ	0.1	S
	C441	ECUE1A104KBQ	0.1	S
	C442	ECUE1A104KBQ	0.1	S
	C443	ECUE1A104KBQ	0.1	S
	C444	ECUE1A104KBQ	0.1	S
	C445	ECUE1A104KBQ	0.1	S
	C446	ECUE1A104KBQ	0.1	S
	C447	ECUE1A104KBQ	0.1	S
	C448	ECUE1A104KBQ	0.1	S
	C449	ECUE1A104KBQ	0.1	S
	C450	ECUE1A104KBQ	0.1	S
	C451	ECUE1A104KBQ	0.1	S
	C452	ECUE1A104KBQ	0.1	S
	C453	ECUE1A104KBQ	0.1	S
	C454	ECUE1A104KBQ	0.1	S
	C455	ECUE1A104KBQ	0.1	S
	C456	ECUE1A104KBQ	0.1	S
	C457	ECUE1A104KBQ	0.1	S
	C458	ECUE1A104KBQ	0.1	S
	C459	ECUE1A104KBQ	0.1	S
	C460	ECUE1A104KBQ	0.1	S
	C461	ECUE1A104KBQ	0.1	S
	C462	ECUE1A104KBQ	0.1	S
	C463	ECUE1A104KBQ	0.1	S
	C464	ECUE1C103KBQ	0.1	S
	C465	ECUE1A104KBQ	0.1	S
	C466	ECUE1A104KBQ	0.1	S
	C467	ECUE1A104KBQ	0.1	S
	C468	ECUE1A104KBQ	0.1	S
	C469	ECUE1A104KBQ	0.1	S
	C470	ECUE1A104KBQ	0.1	S
	C471	ECUE1A104KBQ	0.1	S
	C472	ECUE1A104KBQ	0.1	S
	C473	ECUE1A104KBQ	0.1	S
	C474	ECUE1A104KBQ	0.1	S
	C475	ECUE1A104KBQ	0.1	S
	C476	ECUE1A104KBQ	0.1	S

Safety	Ref. No.	Part No.	Part Name & Description	Remarks
	C477	ECUE1A104KBQ	0.1	S
	C478	ECUE1A104KBQ	0.1	S
	C479	ECUE1A104KBQ	0.1	S
	C485	FIH1H104A220	0.1	
	C486	FIH1H104A220	0.1	
	C487	FIH1H104A220	0.1	
	C488	FIH1H104A220	0.1	
	C489	FIH1H104A220	0.1	
	C490	FIH1H104A220	0.1	
	C491	FIH1H104A220	0.1	
	C492	FIH1H104A220	0.1	
	C493	FIH1H104A220	0.1	
	C494	FIH1H104A220	0.1	
	C495	FIH1H104A220	0.1	
	C496	FIH1H104A220	0.1	
	C497	FIH1H104A220	0.1	
	C498	FIH1H104A220	0.1	
	C499	FIH1H104A220	0.1	
	C500	ECUE1H8R0DCQ	8	
	C501	FIG1H220A565	22p	
	C503	ECUE1A104KBQ	0.1	S
	C504	ECUE1C103KBQ	0.01	S
	C505	ECUE1H181JCQ	180p	S
	C506	ECUE1H181JCQ	180p	S
	C507	ECUE1H102KBQ	0.001	S
	C508	ECJ0EB1A473K	0.047	S
	C509	ECUE1H181JCQ	180p	S
	C510	ECUE1A104KBQ	0.1	S
	C511	ECUE1A104KBQ	0.1	S
	C512	ECUE1A104KBQ	0.1	S
	C513	ECUE1A104KBQ	0.1	S
	C514	ECUE1A104KBQ	0.1	S
	C515	ECUE1H181JCQ	180p	S
	C516	ECUE1H102KBQ	0.001	S
	C517	ECUE1A104KBQ	0.1	S
	C518	FIH1H104A220	0.1	
	C519	ECUE1A104KBQ	0.1	S
	C520	ECUE1H181JCQ	180p	S
	C522	ECUE1A104KBQ	0.1	S
	C523	ECUE1H181JCQ	180p	S
	C524	FIG1H220A565	22p	
	C525	ECUE1H102KBQ	0.001	S
	C526	ECUE1H102KBQ	0.001	S
	C527	ECUE1H102KBQ	0.001	S
	C528	ECUE1H102KBQ	0.001	S
	C529	ECUE1H102KBQ	0.001	S
	C530	ECUE1A104KBQ	0.1	S
	C531	FIJ1A106A024	10	
	C532	ECUE1H181JCQ	180p	S
	C533	ECUE1A104KBQ	0.1	S
	C534	ECUE1A104KBQ	0.1	S
	C535	ECUE1H102KBQ	0.001	S
	C536	ECUE1A104KBQ	0.1	S
	C537	ECUE1A104KBQ	0.1	S
	C538	FIG0J105A007	10	
	C539	ECUE1H102KBQ	0.001	S
	C540	ECUE1A104KBQ	0.1	S
	C541	ECUE1H102KBQ	0.001	S
	C542	ECUE1H181JCQ	180p	S
	C543	ECUE1A104KBQ	0.1	S
	C544	ECUE1C103KBQ	0.01	S
	C545	FIG0J105A007	10	
	C546	ECUE1C103KBQ	0.01	S
	C548	ECUE1H102KBQ	0.001	S
	C549	EEE0JA101WR	100	
	C551	ECUE1H102KBQ	0.001	S
	C552	FIH1H104A220	0.1	
	C553	ECUE1H102KBQ	0.001	S
	C554	ECUE1H102KBQ	0.001	S
	C555	ECUE1A104KBQ	0.1	S
	C556	ECUV0J474KBV	0.47	
	C557	ECUE1H181JCQ	180p	S
	C558	ECUE1H102KBQ	0.001	S

Safety	Ref. No.	Part No.	Part Name & Description	Remarks
	C559	ECUE1H102KBQ	0.001	S
	C561	ECUE1H102KBQ	0.001	S
	C562	ECUE1H102KBQ	0.001	S
	C563	ECUE1H102KBQ	0.001	S
	C565	ECJ0EB1A473K	0.047	S
	C569	ECJ0EB1A473K	0.047	S
	C571	ECUE1A104KBQ	0.1	S
	C572	F1G0J105A007	10	
	C576	ECUE1A104KBQ	0.1	S
	C577	ECUE1H102KBQ	0.001	S
	C600	ECUE1H102KBQ	0.001	S
	C601	ECUE1H102KBQ	0.001	S
	C613	F2G1V1010021	100	
	C615	F1G1H101A557	0.0001	
	C618	F1G0J105A007	10	
	C619	ECUE1H102KBQ	0.001	S
	C620	ECUE1H102KBQ	0.001	S
	C621	ECUE1H102KBQ	0.001	S
	C622	ECUE1H102KBQ	0.001	S
	C623	ECUE1H102KBQ	0.001	S
	C624	ECUE1H102KBQ	0.001	S
	C625	ECUE1H102KBQ	0.001	S
	C626	F1H1H104A220	0.1	
	C627	ECUE1H102KBQ	0.001	S
	C628	ECUE1H102KBQ	0.001	S
	C650	ECUE1C103KBQ	0.01	S
	C652	F1G0J105A007	10	
	C654	ECUE1A104KBQ	0.1	S
	C655	ECUE1H103ZFQ	0.01	S
	C656	ECUE1H103ZFQ	0.01	S
	C657	ECUE1A104KBQ	0.1	S
	C700	ECUE1C103KBQ	0.01	S
	C701	ECUE1H102KBQ	0.001	S
	C702	ECUE1H102KBQ	0.001	S
	C703	ECUE1H102KBQ	0.001	S
	C709	ECUE1H222KBQ	0.0022	S
	C710	ECUE1H222KBQ	0.0022	S
	C711	ECUE1H222KBQ	0.0022	S
	C712	ECUE1H222KBQ	0.0022	S
	C751	ECUE1A104KBQ	0.1	S
	C752	F1J1C106A191	10	
	C753	ECUE1A104KBQ	0.1	S
	C754	ECUE1C103KBQ	0.01	S
	C755	ECUE1C103KBQ	0.01	S
	C756	ECUE1H070DCQ	7p	S
	C757	ECJ0EC1H120J	12p	S
	C758	ECUE1A104KBQ	0.1	S
	C759	ECUE1A104KBQ	0.1	S
	C760	ECUE1A104KBQ	0.1	S
	C761	ECUE1A104KBQ	0.1	S
	C762	F1J1C106A191	10	
	C763	ECUE1A104KBQ	0.1	S
	C764	ECUE1A104KBQ	0.1	S
	C765	ECUE1A104KBQ	0.1	S
	C766	ECUE1A104KBQ	0.1	S
	C767	ECUE1A104KBQ	0.1	S
	C768	F1G1H100A565	1p	
	C800	F1G0J105A007	10	
	C801	F1K1E1060004	10	
	C802	F1H1H104A220	0.1	
	C803	ECUE1A104KBQ	0.1	S
	C804	F1G0J105A007	10	
	C805	F1G1E472A086	0.0047	
	C806	F1G1H100A565	1p	
	C807	F1K0J476A009	47	
	C808	F1K1E1060004	10	
	C809	F1H1H104A220	0.1	
	C810	ECUE1A104KBQ	0.1	S
	C811	F1H1H104A220	0.1	
	C813	F1G0J105A007	10	
	C814	F1G1E472A086	0.0047	
	C815	F2G1V4700028	47	
	C816	F1K0J476A009	47	

Safety	Ref. No.	Part No.	Part Name & Description	Remarks
	C817	F1H1C105A118	1	
	C818	F1H1C105A118	1	
	C819	F1K1E1060004	10	
	C820	F1H1H104A220	0.1	
	C822	F1J1C475A059	4.7	
	C823	ECUE1H102KBQ	0.001	S
	C824	ECUE1H102KBQ	0.001	S
	C826	ECUE1H102KBQ	0.001	S
	C829	F1J1A106A024	10	
	C830	F1G0J105A007	10	
	C831	F1J1A106A024	10	
	C832	F1J1C475A059	4.7	
	C833	F1H1H104A220	0.1	
	C834	F2G1V4700028	47	
	C835	F1J1A106A024	10	
	C836	F1J1A106A024	10	
	C837	F1H1H104A748	0.1	
	C863	ECUE1H471KBQ	470p	S
			(CONNECTORS AND JACK)	
	CN300	K1FY104B0015	CONNECTOR, 4PIN	
	CN301	K1KA05AA0193	CONNECTOR, 5PIN	
	CN500	K1KA09A00236	CONNECTOR, 9PIN	
	CN501	K1KA05A00364	CONNECTOR, 5PIN	
	CN503	K1KA04A00527	CONNECTOR, 4PIN	
	CN504	K1KA10A00412	CONNECTOR, 10PIN	
	CN505	K1KA07A00257	CONNECTOR, 7PIN	
	CN506	K1KA02A00587	CONNECTOR, 2PIN	
	CN507	K1KA06A00428	CONNECTOR, 6PIN	
	CN508	K1KA02A00745	CONNECTOR, 2PIN	
	CN509	K1KA06A00499	CONNECTOR, 6PIN	
	CN510	K1KA04A00527	CONNECTOR, 4PIN	
	CN511	K1KA06A00428	CONNECTOR, 6PIN	
	CN513	K1MY12AA0238	CONNECTOR, 12PIN	
	CN514	K1KA11A00158	CONNECTOR, 11PIN	
	CN515	K1KA08A00440	CONNECTOR, 8PIN	
	CN516	K1KA04AA0193	CONNECTOR, 4PIN	
	CN517	K1KA08A00440	CONNECTOR, 8PIN	
	CN518	K1KA08AA0193	CONNECTOR, 8PIN	
	CN519	K1KA03A00612	CONNECTOR, 3PIN	
	CN700	K1KA12A00315	CONNECTOR, 12PIN	
	CN750	K2LC108B0112	JACK/SOCKET	
	CN800	K1KA03A00495	CONNECTOR, 3PIN	
			(COILS)	
	L300	G1BYYC00026	COIL	
	L305	G1BYYC00026	COIL	
	L306	G1BYYC00026	COIL	
	L372	J0JCC0000278	COIL	
	L508	PFVF2P221SG	COIL	S
	L511	PQLQR2KB113T	COIL	S
	L752	G1BYYYY00010	COIL	
	L753	G1BYYYY00010	COIL	
	L800	G1C4R7MA0445	COIL	
	L801	G1C2R2MA0395	COIL	
	L802	G1C4R7MA0445	COIL	
			(IC FILTERS)	
	L302	J0JCC0000308	IC FILTER	
	L303	J0JCC0000308	IC FILTER	
	L304	J0JAC0000059	IC FILTER	
	L307	J0JYC0000070	IC FILTER	
	L344	J0JCC0000286	IC FILTER	
	L345	J0JCC0000286	IC FILTER	
	L346	J0JCC0000286	IC FILTER	
	L347	J0JCC0000286	IC FILTER	
	L356	J0JCC0000413	IC FILTER	
	L360	J0JCC0000276	IC FILTER	
	L361	J0JCC0000275	IC FILTER	
	L362	J0JCC0000276	IC FILTER	
	L364	J0JCC0000274	IC FILTER	
	L365	J0JCC0000286	IC FILTER	
	L504	J0HAAB000002	IC FILTER	
	L506	J0JCC0000276	IC FILTER	
	L507	J0JCC0000276	IC FILTER	
	L509	J0JAC0000059	IC FILTER	

Safety	Ref. No.	Part No.	Part Name & Description	Remarks
	L510	J0JCC0000276	IC FILTER	
	L750	J0JCC0000276	IC FILTER	
	L751	J0JCC0000251	IC FILTER	
	R559	J0JCC0000276	IC FILTER	
	R750	J0JCC0000308	IC FILTER	
			(RESISTORS)	
	R302	D0GA103JA021	10k	
	R303	D0GA103JA021	10k	
	R304	ERJ2GEJ101	100	S
	R305	D0GA103JA021	10k	
	R306	D0GA102JA021	1k	
	R307	D0GA103JA021	10k	
	R309	ERJ2RKF3301	3.3k	
	R310	ERJ2RKF6801	6.8k	
	R311	ERJ2GE0R00	0	S
	R312	ERJ2GE0R00	0	S
	R313	ERJ2GE0R00	0	S
	R314	ERJ2GE0R00	0	S
	R315	D0GA103JA021	10k	
	R316	D0GA103JA021	10k	
	R317	D0GA470JA021	47	
	R318	D0GA470JA021	47	
	R319	D0GA104JA021	100k	
	R320	ERJ2RKF1212	12.1k	
	R321	D0GA103JA021	10k	
	R322	D0GA103JA021	10k	
	R323	D0GA103JA021	10k	
	R324	ERJ2RKF1212	12.1k	
	R325	D0GA103JA021	10k	
	R327	ERJ2GE0R00	0	S
	R329	ERJ2GE0R00	0	S
	R331	ERJ2GE0R00	0	S
	R332	ERJ2GE0R00	0	S
	R335	ERJ2GE0R00	0	S
	R338	D0GA103JA021	10k	
	R339	ERJ2GEJ823	82k	S
	R345	D0GA103JA021	10k	
	R346	D0GA152JA021	1.5k	
	R347	D0YBR0000020	0	
	R348	D0YBR0000020	0	
	R349	D0GA103JA021	10k	
	R350	D0GA103JA021	10k	
	R351	D0GA103JA021	10k	
	R352	D0GA103JA021	10k	
	R353	D0GA103JA021	10k	
	R354	D0GA103JA021	10k	
	R355	D0GA103JA021	10k	
	R356	ERJ3GEYJ6R8	6.8	
	R357	ERJ3GEYJ6R8	6.8	
	R359	D0GA104JA021	100k	
	R360	D0GA103JA021	10k	
	R363	D0GA103JA021	10k	
	R364	D0GA103JA021	10k	
	R366	D0GA470JA021	47	
	R367	D0GA151JA021	150	
	R368	D0GA151JA021	150	
	R369	D0GA151JA021	150	
	R370	D0GA104JA021	100k	
	R371	D0GA103JA021	10k	
	R372	D0GA103JA021	10k	
	R373	D0GA103JA021	10k	
	R377	D0GA103JA021	10k	
	R379	D0GA470JA021	47	
	R382	ERJ2GE0R00	0	S
	R383	ERJ2GE0R00	0	S
	R384	ERJ2GEJ101	100	S
	R385	D0GA105JA021	1m	
	R386	D0GA151JA021	150	
	R387	D0GA470JA021	47	
	R388	ERJ2GEYJ683	68k	S
	R389	D0GA102JA021	1k	
	R391	D0GA103JA021	10k	
	R395	D0GA470JA021	47	

Safety	Ref. No.	Part No.	Part Name & Description	Remarks
	R398	ERJ2GE0R00	0	S
	R399	D0GA103JA021	10k	
	R400	D0GA470JA021	47	
	R401	D0GA680JA015	68	
	R402	D0GA470JA021	47	
	R403	D0GA470JA021	47	
	R404	D0GA470JA021	47	
	R405	D0GA470JA021	47	
	R406	D0GA470JA021	47	
	R407	D0GA470JA021	47	
	R408	D0GA470JA021	47	
	R409	D0GA560JA015	56	
	R410	D0GA680JA015	68	
	R411	D0GA680JA015	68	
	R412	D0GA470JA021	47	
	R413	D0GA470JA021	47	
	R414	D0GA470JA021	47	
	R415	D0GA470JA021	47	
	R416	D0GA470JA021	47	
	R417	D0GA470JA021	47	
	R418	D0GA470JA021	47	
	R419	D0GA560JA015	56	
	R420	D0GA680JA015	68	
	R421	D0GA470JA021	47	
	R422	D0GA330JA015	33	
	R423	D0GA103JA021	10k	
	R424	D0GA103JA021	10k	
	R425	ERJ2GEJ820	82	S
	R450	D0GA103JA021	10k	
	R451	D0GA103JA021	10k	
	R495	D0YBR0000020	0	
	R496	D0YBR0000020	0	
	R497	D0YBR0000020	0	
	R498	D0YBR0000020	0	
	R500	D0GA220JA021	22	
	R501	ERJ2GEJ101	100	S
	R502	ERJ2GEJ101	100	S
	R503	ERJ2RKF1502	15k	
	R504	D0GA473JA021	47k	
	R505	ERJ2RKF3012	30.1k	
	R506	D0GA223JA015	22k	
	R507	D0GA221JA021	220	
	R508	D0GA330JA015	33	
	R509	D0GA102JA021	1k	
	R510	D0GA562JA021	5.6k	
	R511	D0GA105JA021	1m	
	R512	ERJ2GEJ563	56k	S
	R515	D0GA102JA021	1k	
	R516	ERJ2GEJ622X	6.2k	
	R517	D0GA103JA021	10k	
	R518	D0GA472JA021	4.7k	
	R519	D0GA103JA021	10k	
	R520	D0GA103JA021	10k	
	R521	D0GA470JA021	47	
	R522	ERJ3GEYJ6R8	6.8	
	R523	ERJ2GEJ563	56k	S
	R524	ERJ2GE0R00	0	S
	R525	ERJ2GE0R00	0	S
	R526	D0GA330JA015	33	
	R527	D0GA562JA021	5.6k	
	R528	D0GA330JA015	33	
	R529	ERJ2GE0R00	0	S
	R530	ERJ2GEJ471	470	S
	R531	D0GA330JA015	33	
	R533	D0GA473JA021	47k	
	R534	D0GA222JA021	2.2k	
	R535	D0GA473JA021	47k	
	R536	D0GA474JA021	470k	
	R537	D0GA473JA021	47k	
	R538	D0GA152JA021	1.5k	
	R539	D0GA182JA015	1.8k	
	R541	ERJ2GEYJ331	330	S
	R542	D0GA681JA021	680	

Safety	Ref. No.	Part No.	Part Name & Description	Remarks
	R543	ERJ3GEYJ390	39	
	R544	ERJ2GEYJ331	330	S
	R545	D0GA330JA015	33	
	R546	D0GA681JA021	680	
	R547	D0GA330JA015	33	
	R548	D0GA330JA015	33	
	R549	D0GB560JA057	56	
	R550	ERJ2GEYJ331	330	S
	R551	D0GA473JA021	47k	
	R552	D0GA102JA021	1k	
	R553	D0GA181JA021	180	
	R554	D0GA681JA021	680	
	R555	D0GA472JA021	4.7k	
	R556	ERJ3GEYJ680	68	S
	R557	D0GA473JA021	47k	
	R558	D0GA102JA021	1k	
	R560	D0GA181JA021	180	
	R561	D0GA102JA021	1k	
	R562	D0GA102JA021	1k	
	R563	ERJ2GEJ101	100	S
	R564	ERJ2RKF1802	18k	
	R566	ERJ2GEJ563	56k	S
	R567	D0GA103JA021	10k	
	R568	ERJ2RKF3902	39k	
	R569	D0GA473JA021	47k	
	R570	D0GA102JA021	1k	
	R571	ERJ2GEJ563	56k	S
	R574	D0GA103JA021	10k	
	R575	ERJ2GEJ564	560k	
	R576	D0GA104JA021	100k	
	R577	D0GA472JA021	4.7k	
	R578	D0GA473JA021	47k	
	R579	ERJ2GEJ471	470	S
	R580	D0GA102JA021	1k	
	R581	ERJ2RKF2551	2.55k	
	R582	D0GA473JA021	47k	
	R583	D0GA104JA021	100k	
	R584	ERJ2RKF1502	15k	
	R585	D0GA562JA021	5.6k	
	R586	ERJ2GEJ563	56k	S
	R587	D0GA223JA015	22k	
	R588	D0GA223JA015	22k	
	R589	PQ4R10XJ332	3.3k	S
	R590	ERJ2GEJ563	56k	S
	R591	D0GA473JA021	47k	
	R592	D0GA473JA021	47k	
	R593	PQ4R10XJ332	3.3k	S
	R594	D0GA102JA021	1k	
	R595	D0GA562JA021	5.6k	
	R596	D0GA562JA021	5.6k	
	R598	D0GA562JA021	5.6k	
	R599	D0GA562JA021	5.6k	
	R600	ERJ12YJ680	68	
	R601	ERJ12YJ680	68	
	R602	D0GA473JA021	47k	
	R603	D0GA473JA021	47k	
	R604	D0GA472JA021	4.7k	
	R605	D0GB222JA057	2.2k	
	R606	D0GA562JA021	5.6k	
	R607	D0GB222JA057	2.2k	
	R608	D0GA473JA021	47k	
	R609	PQ4R18XJ121	120	S
	R611	D0GA183JA015	18k	
	R612	D0GA333JA015	33k	
	R613	ERJ2GEJ564	560k	
	R616	ERJ12YJ390H	39	S
	R619	D0GA103JA021	10k	
	R620	ERJ2GEJ563	56k	S
	R621	D0GA562JA021	5.6k	
	R622	D0GA473JA021	47k	
	R623	ERJ2RKF1503	150k	
	R624	ERJ2RKF2202X	22k	
	R627	PQ4R18XJ472	4.7k	S

Safety	Ref. No.	Part No.	Part Name & Description	Remarks
	R629	D0GA102JA021	1k	
	R630	ERJ2RKF1503	150k	
	R632	D0GA562JA021	5.6k	
	R633	D0GA223JA015	22k	
	R634	D0GA562JA021	5.6k	
	R635	ERJ2GEJ563	56k	S
	R636	ERJ2GEYJ683	68k	S
	R637	D0GA103JA021	10k	
	R638	D0GA472JA021	4.7k	
	R640	ERJ2GEJ471	470	S
	R641	D0GA562JA021	5.6k	
	R642	ERJ2GEJ563	56k	S
	R643	ERJ2GEJ471	470	S
	R644	D0GA102JA021	1k	
	R645	ERJ2GEJ471	470	S
	R646	ERJ2GEJ563	56k	S
	R647	D0GA562JA021	5.6k	
	R648	ERJ2GEJ471	470	S
	R649	ERJ2GEJ471	470	S
	R650	ERJ2GEJ471	470	S
	R652	D0GA103JA021	10k	
	R655	ERJ2GEJ823	82k	S
	R656	D0GA473JA021	47k	
	R657	ERJ8GEYJ2R7	2.7	
	R658	ERJ8GEYJ2R7	2.7	
	R659	D0GA103JA021	10k	
	R660	D0GA183JA015	18k	
	R661	D0GA472JA021	4.7k	
	R662	D0GA183JA015	18k	
	R663	D0GA472JA021	4.7k	
	R664	D0GA103JA021	10k	
	R665	D0GA473JA021	47k	
	R666	ERJ8RQFR56V	0.56	
	R667	ERJ8RQFR22	0.22	
	R669	ERJ8RQFR22	0.22	
	R670	ERJ8RQFR56V	0.56	
	R671	ERJ2GEYJ154	150k	S
	R672	ERJ2GEJ184	180k	S
	R673	D0GA473JA021	47k	
	R674	ERJ2GEJ101	100	S
	R683	D0GA103JA021	10k	
	R687	ERJ12YJ680	68	
	R688	ERJ12YJ680	68	
	R689	D0GA473JA021	47k	
	R690	D0GA473JA021	47k	
	R691	D0GB222JA057	2.2k	
	R692	D0GB222JA057	2.2k	
	R693	PQ4R18XJ121	120	S
	R694	D0GA472JA021	4.7k	
	R695	D0GA473JA021	47k	
	R696	D0GA183JA015	18k	
	R697	D0GA333JA015	33k	
	R701	ERJ2GEJ563	56k	S
	R702	ERJ2GEJ563	56k	S
	R703	ERJ2GEJ563	56k	S
	R704	D0GA562JA021	5.6k	
	R705	D0GA562JA021	5.6k	
	R706	D0GA562JA021	5.6k	
	R707	D0GA102JA021	1k	
	R708	D0GA473JA021	47k	
	R711	D0GA102JA021	1k	
	R712	D0GA473JA021	47k	
	R751	ERJ2RKF2491X	2.49k	
	R752	D0GA472JA021	4.7k	
	R755	D0GA472JA021	4.7k	
	R756	D0GA221JA021	220	
	R757	D0GA472JA021	4.7k	
	R758	D0GA472JA021	4.7k	
	R759	D0GA103JA021	10k	
	R767	D0GA220JA021	22	
	R771	D0GA472JA021	4.7k	
	R772	D0GA472JA021	4.7k	
	R773	D0GA472JA021	4.7k	

Safety	Ref. No.	Part No.	Part Name & Description	Remarks
	R800	D0YBR0000020	0	
	R801	D0YBR0000020	0	
	R802	D0YBR0000020	0	
	R803	ERJ2RKF2212	22.1k	
	R804	ERJ2RKF2212	22.1k	
	R805	D0GB103JA057	10k	
	R806	ERJ2RKF7322	73.2k	
	R807	ERJ2GEJ512	5.1k	
	R808	ERJ2RKF1201	1.2k	
	R809	D0GA103JA021	10k	
	R810	D0YBR0000020	0	
	R811	ERJ2RKF1272	12.7k	
	R812	D0YBR0000020	0	
	R813	D0YBR0000020	0	
	R814	D0GA472JA021	4.7k	
	R815	D0GA103JA021	10k	
	R816	D0GA102JA021	1k	
	R817	D0GA103JA021	10k	
	R818	D0GA104JA021	100k	
	R819	D0GA102JA021	1k	
	R820	D0GA102JA021	1k	
	R821	D0GA273JA015	27k	
	R822	D0GA473JA021	47k	
	R823	D0YBR0000020	0	
	R825	D0GA273JA015	27k	
	R826	D0GA473JA021	47k	
	R828	ERJ2GEJ564	560k	
	R829	D0GA473JA021	47k	
	R830	D0GA474JA021	470k	
	R831	D0GA474JA021	470k	
	R832	D0GA474JA021	470k	
	R833	D0GA104JA021	100k	
	R834	D0GA104JA021	100k	
	R835	D0GA103JA021	10k	
	R836	D0GA392JA015	3.9k	
	R837	D0GA472JA021	4.7k	
	R838	ERJ2GEJ471	470	S
	R839	D0GA104JA021	100k	
	R840	ERJ2RKF6341X	6.34k	
	R841	ERJ3GEJ4R7	4.7	S
	R843	ERJ2RKF2200	220	
	R844	ERJ2RKF2200	220	
	R845	ERJ3GEJ510	51	
	R846	ERJ2GEJ471	470	S
	R847	ERJ2GEJ471	470	S
	R851	D0GA103JA021	10k	
	R853	D0GA330JA015	33	
	R854	D0GA330JA015	33	
	L363	D0GA151JA021	150	
	L369	D0GA221JA021	220	
	L370	D0GA221JA021	220	
	L371	D0GA221JA021	220	
			(COMPONENTS PARTS)	
	RA305	EXB28V220JX	RESISTOR ARRAY	
	RA316	EXB28V470JX	RESISTOR ARRAY	
	RA321	EXB28V220JX	RESISTOR ARRAY	
	RA322	EXB28V220JX	RESISTOR ARRAY	
	RA323	EXB28V220JX	RESISTOR ARRAY	
	RA324	EXB28V220JX	RESISTOR ARRAY	
	RA400	EXB28V220JX	RESISTOR ARRAY	
	RA401	EXB28V220JX	RESISTOR ARRAY	
	RA402	EXB28V220JX	RESISTOR ARRAY	
	RA403	EXB28V220JX	RESISTOR ARRAY	
	RA404	EXB28V470JX	RESISTOR ARRAY	
	RA405	EXB28V470JX	RESISTOR ARRAY	
	RA406	EXB28V470JX	RESISTOR ARRAY	
	RA407	EXB28V220JX	RESISTOR ARRAY	
	RA408	EXB28V220JX	RESISTOR ARRAY	
	RA409	EXB28V220JX	RESISTOR ARRAY	
	RA410	EXB28V220JX	RESISTOR ARRAY	
	RA411	EXB28V470JX	RESISTOR ARRAY	
	RA412	EXB28V470JX	RESISTOR ARRAY	
	RA413	EXB28V470JX	RESISTOR ARRAY	

Safety	Ref. No.	Part No.	Part Name & Description	Remarks
	RA414	EXB28V330	RESISTOR ARRAY	
	RA415	EXB28V330	RESISTOR ARRAY	
	RA416	EXB28V330	RESISTOR ARRAY	
	RA417	EXB28V330	RESISTOR ARRAY	
	RA418	EXB28V330	RESISTOR ARRAY	
	RA419	EXB28V330	RESISTOR ARRAY	
	RA420	EXB28V330	RESISTOR ARRAY	
	RA421	EXB28V330	RESISTOR ARRAY	
	RA422	EXB28V330	RESISTOR ARRAY	
	RA423	EXB28V330	RESISTOR ARRAY	
	RA424	EXB28V330	RESISTOR ARRAY	
	RA425	EXB28V103JX	RESISTOR ARRAY	
	RA426	EXB28V103JX	RESISTOR ARRAY	
	RA427	EXB28V103JX	RESISTOR ARRAY	
	RA428	EXB28V103JX	RESISTOR ARRAY	
	RA500	EXB28V470JX	RESISTOR ARRAY	
	RA501	EXB28V470JX	RESISTOR ARRAY	
	RA502	EXB28V470JX	RESISTOR ARRAY	
			(FUSE)	
△	F600	K5H202Y00003	FUSE	
			(CRYSTAL OSCILLATOR)	
	X300	H0J240500074	CRYSTAL OSCILLATOR	
	X301	H0J245500124	CRYSTAL OSCILLATOR	
	X303	H0A327200186	CRYSTAL OSCILLATOR	
	X500	H0J300500039	CRYSTAL OSCILLATOR	
	X750	H0J250500097	CRYSTAL OSCILLATOR	

18.2.4. Main Board (For KX-MB2545EU)

Safety	Ref. No.	Part No.	Part Name & Description	Remarks
	PCB1	PNWP1B2545EU	MAIN BOARD ASS'Y (RTL)	
			(ICs)	
	IC100	C1CB00002689	IC	
	IC101	C1CB00002690	IC	
	IC201	C1CB00001769	IC	
	IC203	C1AB00002556	IC	
	IC300	C1ZBZ0004649	IC	
	IC301	C0EBY0000665	IC	
	IC302	C0ZBZ0001747	IC	
	IC303	C0DBGY03947	IC	
	IC304	C0DBZY000592	IC	
	IC400	C3ABRY000078	IC	
	IC401	C3ABRY000078	IC	
	IC402	PNWI2545EU	IC (ROM)	
	IC403	C0JBAZ001466	IC	
	IC404	C0JBAZ001466	IC	
	IC405	C0JBAZ001539	IC	
	IC406	C0JBAZ001539	IC	
	IC407	C0JBAA000362	IC	
	IC500	C1ZBZ0003879	IC	
	IC502	AN44071A	IC	
	IC503	C0FBAY000092	IC	
	IC504	C0BBBA000024	IC	
	IC750	C1CB00003704	IC	
	IC800	C0DBAYY01433	IC	
	IC801	C0DBAYY01433	IC	
	IC802	C0DBAYY00932	IC	
	IC803	C0DBEYY00102	IC	
			(TRANSISTORS)	
	Q100	DSC710100L	TRANSISTOR (SI)	
	Q101	DSC710100L	TRANSISTOR (SI)	
	Q102	B1ABDP000005	TRANSISTOR (SI)	
	Q103	B1ABDP000005	TRANSISTOR (SI)	
	Q104	B1ADGF000008	TRANSISTOR (SI)	
	Q105	DRC9123J0L	TRANSISTOR (SI)	
	Q200	B1GBCFGN0005	TRANSISTOR (SI)	
	Q500	DSC9001R0L	TRANSISTOR (SI)	
	Q501	B1GBCFGN0005	TRANSISTOR (SI)	
	Q502	B1GBCFGN0005	TRANSISTOR (SI)	
	Q503	B1GBCFGN0005	TRANSISTOR (SI)	
	Q504	B1GBCFGN0005	TRANSISTOR (SI)	
	Q505	B1GBCFGN0005	TRANSISTOR (SI)	

Safety	Ref. No.	Part No.	Part Name & Description	Remarks
	Q506	B1GBCFGN0005	TRANSISTOR (SI)	
	Q507	B1ABGE000014	TRANSISTOR (SI)	
	Q508	B1ADKE000002	TRANSISTOR (SI)	
	Q509	B1ADKE000002	TRANSISTOR (SI)	
	Q510	B1ABGE000014	TRANSISTOR (SI)	
	Q511	B1ABGE000014	TRANSISTOR (SI)	
	Q512	B1GBCFGN0005	TRANSISTOR (SI)	
	Q513	B1GBCFGN0005	TRANSISTOR (SI)	
	Q514	B1ABGE000011	TRANSISTOR (SI)	
	Q516	B1ABGE000011	TRANSISTOR (SI)	
	Q517	B1ABGE000011	TRANSISTOR (SI)	
	Q518	B1ADGE000012	TRANSISTOR (SI)	
	Q520	B1GBCFGN0005	TRANSISTOR (SI)	
	Q525	B1GBCFGN0005	TRANSISTOR (SI)	
	Q526	B1GBCFGN0005	TRANSISTOR (SI)	
	Q527	DRC9123J0L	TRANSISTOR (SI)	
	Q528	DSC9001R0L	TRANSISTOR (SI)	
	Q529	B1GBCFGN0005	TRANSISTOR (SI)	
	Q530	DSC9001R0L	TRANSISTOR (SI)	
	Q600	B1ADGE000012	TRANSISTOR (SI)	
	Q601	B1ADGE000012	TRANSISTOR (SI)	
	Q602	B1GBCFGN0005	TRANSISTOR (SI)	
	Q603	B1ADGE000012	TRANSISTOR (SI)	
	Q604	B1ADCF000020	TRANSISTOR (SI)	
	Q605	DRA9143Z0L	TRANSISTOR (SI)	
	Q607	DSC9001R0L	TRANSISTOR (SI)	
	Q608	B1ADGE000012	TRANSISTOR (SI)	
	Q609	B1ADGE000012	TRANSISTOR (SI)	
	Q610	B1GBCFGN0005	TRANSISTOR (SI)	
	Q611	B1GBCFGN0005	TRANSISTOR (SI)	
	Q612	B1GBCFGN0005	TRANSISTOR (SI)	
	Q613	B1ADCF000020	TRANSISTOR (SI)	
	Q614	DRA9143Z0L	TRANSISTOR (SI)	
	Q650	B1ADCF000020	TRANSISTOR (SI)	
	Q651	DSC9001R0L	TRANSISTOR (SI)	
	Q700	B1ABGE000014	TRANSISTOR (SI)	
	Q701	B1ABGE000014	TRANSISTOR (SI)	
	Q702	B1GBCFGN0005	TRANSISTOR (SI)	
	Q703	DRA9143Z0L	TRANSISTOR (SI)	
	Q800	B1CHND000004	TRANSISTOR (SI)	
	Q801	B1GBCFGN0005	TRANSISTOR (SI)	
	Q802	B1CHND000004	TRANSISTOR (SI)	
	Q803	DRA9143Z0L	TRANSISTOR (SI)	
	Q804	DSC9001R0L	TRANSISTOR (SI)	
	Q805	DSC9001R0L	TRANSISTOR (SI)	
	Q806	B1GBCFGN0005	TRANSISTOR (SI)	
	Q807	B1CHQD000018	TRANSISTOR (SI)	
	Q808	B1CHQD000018	TRANSISTOR (SI)	
	Q809	B1ADCF000020	TRANSISTOR (SI)	
	Q810	DSC9001R0L	TRANSISTOR (SI)	
	Q812	B1GBCFGN0005	TRANSISTOR (SI)	
	Q813	B1CHQD000018	TRANSISTOR (SI)	
	Q814	B1ADCF000020	TRANSISTOR (SI)	
	Q815	B1GBCFGN0005	TRANSISTOR (SI)	
			(DIODES)	
	D100	DZ2W30000L	DIODE (SI)	
	D101	B0EDER000009	DIODE (SI)	
	D102	DA2J10100L	DIODE (SI)	
	D103	DZ2J056M0L	DIODE (SI)	
	D104	DZ2J056M0L	DIODE (SI)	
	D301	DD2S06200L	DIODE (SI)	
	D302	DD2S06200L	DIODE (SI)	
	D306	B0ZBZ0000146	DIODE (SI)	
	D600	DA2J10100L	DIODE (SI)	
	D601	DA2J10100L	DIODE (SI)	
	D801	DZ2W05600L	DIODE (SI)	S
	D803	DZ2W05600L	DIODE (SI)	S
	D804	B0JCND000031	DIODE (SI)	
	D805	B0BC6R5A0541	DIODE (SI)	
	D806	PJVDJADAN202	DIODE (SI)	S
	D807	DA2J10100L	DIODE (SI)	
	DA300	B0ADEJ000025	DIODE (SI)	
	LED750	B3ABB0000331	DIODE (SI)	

Safety	Ref. No.	Part No.	Part Name & Description	Remarks
			(BATTERY)	
	BAT300	BR2032/1HF1	BATTERY	S
			(CAPACITORS)	
		C100	ECUE1C103KBQ 0.01	S
		C101	ECUE1A104KBQ 0.1	S
		C102	ECUE1A104KBQ 0.1	S
	△	C103	F1BAF330A048 33p	
	△	C104	F1BAF330A048 33p	
		C105	EEE1HA010SR 1	
		C106	ECUE1A104KBQ 0.1	S
		C107	ECUE1A104KBQ 0.1	S
		C108	F1J2E121A023 0.00012	
		C109	F1J2E121A023 0.00012	
		C110	F1G1H272A571 0.0027	
		C111	ECUE1C103KBQ 0.01	S
		C112	ECUE1C103KBQ 0.01	S
		C113	F1J2E1030004 0.01	
		C114	F1G1H101A557 0.0001	
		C115	F0C2E1050004 1	
	△	C116	F1BAF471A049 470p	
	△	C117	F1BAF471A049 470p	
	△	C119	F1BAF330A048 33p	
		C203	ECUE1C103KBQ 0.01	S
		C204	ECUE1A104KBQ 0.1	S
		C206	ECUE1C223KBQ 0.022	S
		C207	ECUE1A104KBQ 0.1	S
		C209	ECUE1A104KBQ 0.1	S
		C211	ECUE1A104KBQ 0.1	S
		C212	ECUE1C223KBQ 0.022	S
		C226	F1G0J105A007 10	
		C227	F1G0J105A007 10	
		C229	ECJ0EB1H392K 0.0039	
		C232	F1J0J2260004 220	
		C300	ECUE1A104KBQ 0.1	S
		C301	ECUE1C103KBQ 0.01	S
		C302	ECUE1A104KBQ 0.1	S
		C303	ECUE1A104KBQ 0.1	S
		C304	ECUE1A104KBQ 0.1	S
		C305	ECUE1A104KBQ 0.1	S
		C306	ECUE1A104KBQ 0.1	S
		C307	ECUE1A104KBQ 0.1	S
		C308	F1G0J105A007 10	
		C309	F1G1A273A032 0.27	
		C310	F1G1H100A565 1p	
		C311	F1G1H180A565 18p	
		C312	ECUE1A104KBQ 0.1	S
		C313	F1G1H180A565 18p	
		C314	F1G1H180A565 18p	
		C319	F1G0J105A007 10	
		C322	ECUE1A104KBQ 0.1	S
		C325	F1G0J105A007 10	
		C326	ECUE1C103KBQ 0.01	S
		C327	ECUE1A104KBQ 0.1	S
		C328	F1G0J224A044 0.22	
		C329	F1G0J224A044 0.22	
		C330	F1H0J105A037 1	
		C331	F1H0J105A037 1	
		C340	ECUE1A104KBQ 0.1	S
		C341	ECUE1A104KBQ 0.1	S
		C342	ECUE1A104KBQ 0.1	S
		C343	ECUE1A104KBQ 0.1	S
		C344	ECUE1C103KBQ 0.01	S
		C351	F1G1H101A557 0.0001	
		C356	ECUE1A104KBQ 0.1	S
		C357	ECUE1A104KBQ 0.1	S
		C358	ECUE1A104KBQ 0.1	S
		C359	ECUE1A104KBQ 0.1	S
		C360	ECUE1A104KBQ 0.1	S
		C361	ECUE1A104KBQ 0.1	S
		C362	ECUE1A104KBQ 0.1	S
		C363	ECUE1A104KBQ 0.1	S
		C364	ECUE1A104KBQ 0.1	S
		C365	ECUE1H102KBQ 0.001	S

Safety	Ref. No.	Part No.	Part Name & Description	Remarks
	C366	ECUE1A104KBQ	0.1	S
	C367	FIG0J105A007	10	
	C368	FIG0J105A007	10	
	C369	FIG0J105A007	10	
	C370	FIH1A105A025	1	
	C371	FIH0J1060006	10	
	C400	FIH0J105A037	1	
	C401	FIH0J105A037	1	
	C402	FIH0J105A037	1	
	C403	FIH0J105A037	1	
	C404	FIH0J105A037	1	
	C405	FIH0J105A037	1	
	C406	FIH0J105A037	1	
	C407	FIH0J105A037	1	
	C408	ECUE1A104KBQ	0.1	S
	C409	ECUE1A104KBQ	0.1	S
	C410	ECUE1A104KBQ	0.1	S
	C411	ECUE1A104KBQ	0.1	S
	C412	ECUE1A104KBQ	0.1	S
	C413	ECUE1A104KBQ	0.1	S
	C414	ECUE1A104KBQ	0.1	S
	C440	ECUE1A104KBQ	0.1	S
	C441	ECUE1A104KBQ	0.1	S
	C442	ECUE1A104KBQ	0.1	S
	C443	ECUE1A104KBQ	0.1	S
	C444	ECUE1A104KBQ	0.1	S
	C445	ECUE1A104KBQ	0.1	S
	C446	ECUE1A104KBQ	0.1	S
	C447	ECUE1A104KBQ	0.1	S
	C448	ECUE1A104KBQ	0.1	S
	C449	ECUE1A104KBQ	0.1	S
	C450	ECUE1A104KBQ	0.1	S
	C451	ECUE1A104KBQ	0.1	S
	C452	ECUE1A104KBQ	0.1	S
	C453	ECUE1A104KBQ	0.1	S
	C454	ECUE1A104KBQ	0.1	S
	C455	ECUE1A104KBQ	0.1	S
	C456	ECUE1A104KBQ	0.1	S
	C457	ECUE1A104KBQ	0.1	S
	C458	ECUE1A104KBQ	0.1	S
	C459	ECUE1A104KBQ	0.1	S
	C460	ECUE1A104KBQ	0.1	S
	C461	ECUE1A104KBQ	0.1	S
	C462	ECUE1A104KBQ	0.1	S
	C463	ECUE1A104KBQ	0.1	S
	C464	ECUE1A104KBQ	0.1	S
	C465	ECUE1A104KBQ	0.1	S
	C466	ECUE1A104KBQ	0.1	S
	C467	ECUE1A104KBQ	0.1	S
	C468	ECUE1A104KBQ	0.1	S
	C469	ECUE1A104KBQ	0.1	S
	C470	ECUE1A104KBQ	0.1	S
	C471	ECUE1A104KBQ	0.1	S
	C472	ECUE1A104KBQ	0.1	S
	C473	ECUE1A104KBQ	0.1	S
	C474	ECUE1A104KBQ	0.1	S
	C475	ECUE1A104KBQ	0.1	S
	C476	ECUE1A104KBQ	0.1	S
	C477	ECUE1A104KBQ	0.1	S
	C478	ECUE1A104KBQ	0.1	S
	C479	ECUE1A104KBQ	0.1	S
	C485	FIH1H104A220	0.1	
	C486	FIH1H104A220	0.1	
	C487	FIH1H104A220	0.1	
	C488	FIH1H104A220	0.1	
	C489	FIH1H104A220	0.1	
	C490	FIH1H104A220	0.1	
	C491	FIH1H104A220	0.1	
	C492	FIH1H104A220	0.1	
	C493	FIH1H104A220	0.1	
	C494	FIH1H104A220	0.1	
	C495	FIH1H104A220	0.1	
	C496	FIH1H104A220	0.1	

Safety	Ref. No.	Part No.	Part Name & Description	Remarks
	C497	FIH1H104A220	0.1	
	C498	FIH1H104A220	0.1	
	C499	FIH1H104A220	0.1	
	C500	ECUE1H8R0DCQ	8	
	C501	FIG1H220A565	22p	
	C503	ECUE1A104KBQ	0.1	S
	C504	ECUE1C103KBQ	0.01	S
	C505	ECUE1H181JCQ	180p	S
	C506	ECUE1H181JCQ	180p	S
	C507	ECUE1H102KBQ	0.001	S
	C508	ECJ0EB1A473K	0.047	S
	C509	ECUE1H181JCQ	180p	S
	C510	ECUE1A104KBQ	0.1	S
	C511	ECUE1A104KBQ	0.1	S
	C512	ECUE1A104KBQ	0.1	S
	C513	ECUE1A104KBQ	0.1	S
	C514	ECUE1A104KBQ	0.1	S
	C515	ECUE1H181JCQ	180p	S
	C516	ECUE1H102KBQ	0.001	S
	C517	ECUE1A104KBQ	0.1	S
	C518	FIH1H104A220	0.1	
	C519	ECUE1A104KBQ	0.1	S
	C520	ECUE1H181JCQ	180p	S
	C522	ECUE1A104KBQ	0.1	S
	C523	ECUE1H181JCQ	180p	S
	C524	FIG1H220A565	22p	
	C525	ECUE1H102KBQ	0.001	S
	C526	ECUE1H102KBQ	0.001	S
	C527	ECUE1H102KBQ	0.001	S
	C528	ECUE1H102KBQ	0.001	S
	C529	ECUE1H102KBQ	0.001	S
	C530	ECUE1A104KBQ	0.1	S
	C531	FIJ1A106A024	10	
	C532	ECUE1H181JCQ	180p	S
	C533	ECUE1A104KBQ	0.1	S
	C534	ECUE1A104KBQ	0.1	S
	C535	ECUE1H102KBQ	0.001	S
	C536	ECUE1A104KBQ	0.1	S
	C537	ECUE1A104KBQ	0.1	S
	C538	FIG0J105A007	10	
	C539	ECUE1H102KBQ	0.001	S
	C540	ECUE1A104KBQ	0.1	S
	C541	ECUE1H102KBQ	0.001	S
	C542	ECUE1H181JCQ	180p	S
	C543	ECUE1A104KBQ	0.1	S
	C544	ECUE1C103KBQ	0.01	S
	C545	FIG0J105A007	10	
	C546	ECUE1C103KBQ	0.01	S
	C548	ECUE1H102KBQ	0.001	S
	C549	EEE0JA101WR	100	
	C551	ECUE1H102KBQ	0.001	S
	C552	FIH1H104A220	0.1	
	C553	ECUE1H102KBQ	0.001	S
	C554	ECUE1H102KBQ	0.001	S
	C555	ECUE1A104KBQ	0.1	S
	C556	ECUV0J474KBV	0.47	
	C557	ECUE1H181JCQ	180p	S
	C558	ECUE1H102KBQ	0.001	S
	C559	ECUE1H102KBQ	0.001	S
	C561	ECUE1H102KBQ	0.001	S
	C562	ECUE1H102KBQ	0.001	S
	C563	ECUE1H102KBQ	0.001	S
	C565	ECJ0EB1A473K	0.047	S
	C569	ECJ0EB1A473K	0.047	S
	C571	ECUE1A104KBQ	0.1	S
	C572	FIG0J105A007	10	
	C576	ECUE1A104KBQ	0.1	S
	C577	ECUE1H102KBQ	0.001	S
	C600	ECUE1H102KBQ	0.001	S
	C601	ECUE1H102KBQ	0.001	S
	C613	F2G1V1010021	100	
	C615	FIG1H101A557	0.0001	
	C618	FIG0J105A007	10	

Safety	Ref. No.	Part No.	Part Name & Description	Remarks
	C619	ECUE1H102KBQ	0.001	S
	C620	ECUE1H102KBQ	0.001	S
	C621	ECUE1H102KBQ	0.001	S
	C622	ECUE1H102KBQ	0.001	S
	C623	ECUE1H102KBQ	0.001	S
	C624	ECUE1H102KBQ	0.001	S
	C625	ECUE1H102KBQ	0.001	S
	C626	F1H1H104A220	0.1	
	C627	ECUE1H102KBQ	0.001	S
	C628	ECUE1H102KBQ	0.001	S
	C650	ECUE1C103KBQ	0.01	S
	C652	F1G0J105A007	10	
	C654	ECUE1A104KBQ	0.1	S
	C655	ECUE1H103ZFQ	0.01	S
	C656	ECUE1H103ZFQ	0.01	S
	C657	ECUE1A104KBQ	0.1	S
	C700	ECUE1C103KBQ	0.01	S
	C701	ECUE1H102KBQ	0.001	S
	C702	ECUE1H102KBQ	0.001	S
	C703	ECUE1H102KBQ	0.001	S
	C709	ECUE1H222KBQ	0.0022	S
	C710	ECUE1H222KBQ	0.0022	S
	C711	ECUE1H222KBQ	0.0022	S
	C712	ECUE1H222KBQ	0.0022	S
	C751	ECUE1A104KBQ	0.1	S
	C752	F1J1C106A191	10	
	C753	ECUE1A104KBQ	0.1	S
	C754	ECUE1C103KBQ	0.01	S
	C755	ECUE1C103KBQ	0.01	S
	C756	ECUE1H070DCQ	7p	S
	C757	ECJ0EC1H120J	12p	S
	C758	ECUE1A104KBQ	0.1	S
	C759	ECUE1A104KBQ	0.1	S
	C760	ECUE1A104KBQ	0.1	S
	C761	ECUE1A104KBQ	0.1	S
	C762	F1J1C106A191	10	
	C763	ECUE1A104KBQ	0.1	S
	C764	ECUE1A104KBQ	0.1	S
	C765	ECUE1A104KBQ	0.1	S
	C766	ECUE1A104KBQ	0.1	S
	C767	ECUE1A104KBQ	0.1	S
	C768	F1G1H100A565	1p	
	C800	F1G0J105A007	10	
	C801	F1K1E1060004	10	
	C802	F1H1H104A220	0.1	
	C803	ECUE1A104KBQ	0.1	S
	C804	F1G0J105A007	10	
	C805	F1G1E472A086	0.0047	
	C806	F1G1H100A565	1p	
	C807	F1K0J476A009	47	
	C808	F1K1E1060004	10	
	C809	F1H1H104A220	0.1	
	C810	ECUE1A104KBQ	0.1	S
	C811	F1H1H104A220	0.1	
	C813	F1G0J105A007	10	
	C814	F1G1E472A086	0.0047	
	C815	F2G1V4700028	47	
	C816	F1K0J476A009	47	
	C817	F1H1C105A118	1	
	C818	F1H1C105A118	1	
	C819	F1K1E1060004	10	
	C820	F1H1H104A220	0.1	
	C822	F1J1C475A059	4.7	
	C823	ECUE1H102KBQ	0.001	S
	C824	ECUE1H102KBQ	0.001	S
	C826	ECUE1H102KBQ	0.001	S
	C829	F1J1A106A024	10	
	C830	F1G0J105A007	10	
	C831	F1J1A106A024	10	
	C832	F1J1C475A059	4.7	
	C833	F1H1H104A220	0.1	
	C834	F2G1V4700028	47	
	C835	F1J1A106A024	10	

Safety	Ref. No.	Part No.	Part Name & Description	Remarks
	C836	F1J1A106A024	10	
	C837	F1H1H104A748	0.1	
	C863	ECUE1H471KBQ	470p	S
			(CONNECTORS AND JACKS)	
	CN100	K2LB106B0053	JACK/SOCKET	
	CN101	K2LB106B0053	JACK/SOCKET	
	CN201	K1KA02A00587	CONNECTOR, 2PIN	
	CN300	K1FY104B0015	CONNECTOR, 4PIN	
	CN301	K1KA05AA0193	CONNECTOR, 5PIN	
	CN500	K1KA09A00236	CONNECTOR, 9PIN	
	CN501	K1KA05A00364	CONNECTOR, 5PIN	
	CN503	K1KA04A00527	CONNECTOR, 4PIN	
	CN504	K1KA10A00412	CONNECTOR, 10PIN	
	CN505	K1KA07A00257	CONNECTOR, 7PIN	
	CN506	K1KA02A00587	CONNECTOR, 2PIN	
	CN507	K1KA06A00428	CONNECTOR, 6PIN	
	CN508	K1KA02A00745	CONNECTOR, 2PIN	
	CN509	K1KA06A00499	CONNECTOR, 6PIN	
	CN510	K1KA04A00527	CONNECTOR, 4PIN	
	CN511	K1KA06A00428	CONNECTOR, 6PIN	
	CN513	K1MY12AA0238	CONNECTOR, 12PIN	
	CN514	K1KA11A00158	CONNECTOR, 11PIN	
	CN515	K1KA08A00440	CONNECTOR, 8PIN	
	CN516	K1KA04AA0193	CONNECTOR, 4PIN	
	CN517	K1KA08A00440	CONNECTOR, 8PIN	
	CN518	K1KA08AA0193	CONNECTOR, 8PIN	
	CN519	K1KA03A00612	CONNECTOR, 3PIN	
	CN700	K1KA12A00315	CONNECTOR, 12PIN	
	CN750	K2LC108B0112	JACK/SOCKET	
	CN800	K1KA03A00495	CONNECTOR, 3PIN	
			(COILS)	
	L104	PQLQR2BT	COIL	S
	L105	PQLQR2BT	COIL	S
	L106	PQLQR2BT	COIL	S
	L107	PQLQR2BT	COIL	S
	L108	PQLQR2BT	COIL	S
	L109	PQLQR2BT	COIL	S
	L110	G0B862C00003	COIL	
	L300	G1BYYC00026	COIL	
	L305	G1BYYC00026	COIL	
	L306	G1BYYC00026	COIL	
	L372	J0JCC0000278	COIL	
	L508	PFVF2P221SG	COIL	S
	L511	PQLQR2KB113T	COIL	S
	L752	G1BYYYY00010	COIL	
	L753	G1BYYYY00010	COIL	
	L800	G1C4R7MA0445	COIL	
	L801	G1C2R2MA0395	COIL	
	L802	G1C4R7MA0445	COIL	
			(IC FILTERS)	
	L100	J0JCC0000002	IC FILTER	
	L101	J0JCC0000002	IC FILTER	
	L102	J0JBC0000040	IC FILTER	
	L103	J0JBC0000040	IC FILTER	
	L210	J0JCC0000288	IC FILTER	
	L211	J0JCC0000288	IC FILTER	
	L214	J0JCC0000276	IC FILTER	
	L302	J0JCC0000308	IC FILTER	
	L303	J0JCC0000308	IC FILTER	
	L304	J0JAC0000059	IC FILTER	
	L307	J0JYC0000070	IC FILTER	
	L344	J0JCC0000286	IC FILTER	
	L345	J0JCC0000286	IC FILTER	
	L346	J0JCC0000286	IC FILTER	
	L347	J0JCC0000286	IC FILTER	
	L348	J0JCC0000277	IC FILTER	
	L349	J0JCC0000277	IC FILTER	
	L350	J0JCC0000277	IC FILTER	
	L351	J0JCC0000277	IC FILTER	
	L352	J0JCC0000277	IC FILTER	
	L353	J0JCC0000277	IC FILTER	
	L354	J0JCC0000277	IC FILTER	
	L355	J0JCC0000277	IC FILTER	

Safety	Ref. No.	Part No.	Part Name & Description	Remarks
	L356	J0JCC0000413	IC FILTER	
	L357	J0MAB0000144	IC FILTER	
	L358	J0JCC0000277	IC FILTER	
	L359	J0JCC0000277	IC FILTER	
	L360	J0JCC0000276	IC FILTER	
	L361	J0JCC0000275	IC FILTER	
	L362	J0JCC0000276	IC FILTER	
	L364	J0JCC0000274	IC FILTER	
	L365	J0JCC0000286	IC FILTER	
	L504	J0HAAB000002	IC FILTER	
	L506	J0JCC0000276	IC FILTER	
	L507	J0JCC0000276	IC FILTER	
	L509	J0JAC0000059	IC FILTER	
	L510	J0JCC0000276	IC FILTER	
	L750	J0JCC0000276	IC FILTER	
	L751	J0JCC0000251	IC FILTER	
	R559	J0JCC0000276	IC FILTER	
	R750	J0JCC0000308	IC FILTER	
			(RESISTORS)	
	R100	D0GA473JA021	47k	
	R102	D0GB560JA057	56	
	R103	D0GB560JA057	56	
	R104	ERJ2RKF1004	1m	
	R105	ERJ12SF1071	1m	
	R106	ERJ6GEYJ515	5.1m	
	R107	ERJ6GEYJ515	5.1m	
	R108	ERJ12SF3651	3.65k	
	R109	D0GF156JA051	15m	
	R110	D0GF156JA051	15m	
	R111	D0GA151JA021	150	
	R112	ERJ8ENF5360	536	
	R113	ERJ12SF73R2	73.2	
	R114	ERJ12SF2491	2.49k	
	R115	D0GA104JA021	100k	
	R116	D0GA104JA021	100k	
	R117	ERDS1TJ223	22k	S
	R119	ERG1SJ120E	12	
	R121	D0GA103JA021	10k	
	R122	PQ4R18XJ100	10	S
	R200	D0YBR0000020	0	
	R204	D0YBR0000020	0	
	R205	D0YBR0000020	0	
	R206	D0GA473JA021	47k	
	R207	D0GA332JA015	3.3k	
	R212	D0GA472JA021	4.7k	
	R213	D0GA103JA021	10k	
	R215	D0GA105JA021	1m	
	R216	D0GA472JA021	4.7k	
	R227	D0GA102JA021	1k	
	R229	D0GA273JA015	27k	
	R233	PQ4R18XJ100	10	S
	R234	ERJ2GEYJ154	150k	S
	R235	D0GA124JA015	120k	
	R302	D0GA103JA021	10k	
	R303	D0GA103JA021	10k	
	R304	ERJ2GEJ101	100	S
	R305	D0GA103JA021	10k	
	R306	D0GA102JA021	1k	
	R307	D0GA103JA021	10k	
	R309	ERJ2RKF3301	3.3k	
	R310	ERJ2RKF6801	6.8k	
	R311	ERJ2GE0R00	0	S
	R312	ERJ2GE0R00	0	S
	R313	ERJ2GE0R00	0	S
	R314	ERJ2GE0R00	0	S
	R315	D0GA103JA021	10k	
	R316	D0GA103JA021	10k	
	R317	D0GA470JA021	47	
	R318	D0GA470JA021	47	
	R319	D0GA104JA021	100k	
	R320	ERJ2RKF1212	12.1k	
	R321	D0GA103JA021	10k	
	R322	D0GA103JA021	10k	

Safety	Ref. No.	Part No.	Part Name & Description	Remarks
	R323	D0GA103JA021	10k	
	R324	ERJ2RKF1212	12.1k	
	R325	D0GA103JA021	10k	
	R327	ERJ2GE0R00	0	S
	R329	ERJ2GE0R00	0	S
	R331	ERJ2GE0R00	0	S
	R332	ERJ2GE0R00	0	S
	R335	ERJ2GE0R00	0	S
	R338	D0GA103JA021	10k	
	R339	ERJ2GEJ823	82k	S
	R345	D0GA103JA021	10k	
	R346	D0GA152JA021	1.5k	
	R347	D0YBR0000020	0	
	R348	D0YBR0000020	0	
	R352	D0GA103JA021	10k	
	R354	D0GA103JA021	10k	
	R355	D0GA103JA021	10k	
	R356	ERJ3GEYJ6R8	6.8	
	R357	ERJ3GEYJ6R8	6.8	
	R359	D0GA104JA021	100k	
	R361	D0GA103JA021	10k	
	R362	D0GA103JA021	10k	
	R364	D0GA103JA021	10k	
	R366	D0GA470JA021	47	
	R367	D0GA151JA021	150	
	R368	D0GA151JA021	150	
	R369	D0GA151JA021	150	
	R370	D0GA104JA021	100k	
	R371	D0GA103JA021	10k	
	R372	D0GA103JA021	10k	
	R373	D0GA103JA021	10k	
	R377	D0GA103JA021	10k	
	R379	D0GA470JA021	47	
	R382	ERJ2GE0R00	0	S
	R383	ERJ2GE0R00	0	S
	R384	ERJ2GEJ101	100	S
	R385	D0GA105JA021	1m	
	R386	D0GA151JA021	150	
	R387	D0GA470JA021	47	
	R388	ERJ2GEYJ683	68k	S
	R389	D0GA102JA021	1k	
	R391	D0GA103JA021	10k	
	R395	D0GA470JA021	47	
	R399	D0GA103JA021	10k	
	R400	D0GA470JA021	47	
	R401	D0GA680JA015	68	
	R402	D0GA470JA021	47	
	R403	D0GA470JA021	47	
	R404	D0GA470JA021	47	
	R405	D0GA470JA021	47	
	R406	D0GA470JA021	47	
	R407	D0GA470JA021	47	
	R408	D0GA470JA021	47	
	R409	D0GA560JA015	56	
	R410	D0GA680JA015	68	
	R411	D0GA680JA015	68	
	R412	D0GA470JA021	47	
	R413	D0GA470JA021	47	
	R414	D0GA470JA021	47	
	R415	D0GA470JA021	47	
	R416	D0GA470JA021	47	
	R417	D0GA470JA021	47	
	R418	D0GA470JA021	47	
	R419	D0GA560JA015	56	
	R420	D0GA680JA015	68	
	R421	D0GA470JA021	47	
	R422	D0GA330JA015	33	
	R423	D0GA103JA021	10k	
	R424	D0GA103JA021	10k	
	R425	ERJ2GEJ820	82	S
	R450	D0GA103JA021	10k	
	R451	D0GA103JA021	10k	
	R495	D0YBR0000020	0	

Safety	Ref. No.	Part No.	Part Name & Description	Remarks
	R496	D0YBR0000020	0	
	R497	D0YBR0000020	0	
	R498	D0YBR0000020	0	
	R500	D0GA220JA021	22	
	R501	ERJ2GEJ101	100	S
	R502	ERJ2GEJ101	100	S
	R503	ERJ2RKF1502	15k	
	R504	D0GA473JA021	47k	
	R505	ERJ2RKF3012	30.1k	
	R506	D0GA223JA015	22k	
	R507	D0GA221JA021	220	
	R508	D0GA330JA015	33	
	R509	D0GA102JA021	1k	
	R510	D0GA562JA021	5.6k	
	R511	D0GA105JA021	1m	
	R512	ERJ2GEJ563	56k	S
	R515	D0GA102JA021	1k	
	R516	ERJ2GEJ622X	6.2k	
	R517	D0GA103JA021	10k	
	R518	D0GA472JA021	4.7k	
	R519	D0GA103JA021	10k	
	R520	D0GA103JA021	10k	
	R521	D0GA470JA021	47	
	R522	ERJ3GEYJ6R8	6.8	
	R523	ERJ2GEJ563	56k	S
	R524	ERJ2GEOR00	0	S
	R525	ERJ2GEOR00	0	S
	R526	D0GA330JA015	33	
	R527	D0GA562JA021	5.6k	
	R528	D0GA330JA015	33	
	R529	ERJ2GEOR00	0	S
	R530	ERJ2GEJ471	470	S
	R531	D0GA330JA015	33	
	R533	D0GA473JA021	47k	
	R534	D0GA222JA021	2.2k	
	R535	D0GA473JA021	47k	
	R536	D0GA474JA021	470k	
	R537	D0GA473JA021	47k	
	R538	D0GA152JA021	1.5k	
	R539	D0GA182JA015	1.8k	
	R541	ERJ2GEYJ331	330	S
	R542	D0GA681JA021	680	
	R543	ERJ3GEYJ390	39	
	R544	ERJ2GEYJ331	330	S
	R545	D0GA330JA015	33	
	R546	D0GA681JA021	680	
	R547	D0GA330JA015	33	
	R548	D0GA330JA015	33	
	R549	D0GB560JA057	56	
	R550	ERJ2GEYJ331	330	S
	R551	D0GA473JA021	47k	
	R552	D0GA102JA021	1k	
	R553	D0GA181JA021	180	
	R554	D0GA681JA021	680	
	R555	D0GA472JA021	4.7k	
	R556	ERJ3GEYJ680	68	S
	R557	D0GA473JA021	47k	
	R558	D0GA102JA021	1k	
	R560	D0GA181JA021	180	
	R561	D0GA102JA021	1k	
	R562	D0GA102JA021	1k	
	R563	ERJ2GEJ101	100	S
	R564	ERJ2RKF1802	18k	
	R566	ERJ2GEJ563	56k	S
	R567	D0GA103JA021	10k	
	R568	ERJ2RKF3902	39k	
	R569	D0GA473JA021	47k	
	R570	D0GA102JA021	1k	
	R571	ERJ2GEJ563	56k	S
	R574	D0GA103JA021	10k	
	R575	ERJ2GEJ564	560k	
	R576	D0GA104JA021	100k	
	R577	D0GA472JA021	4.7k	

Safety	Ref. No.	Part No.	Part Name & Description	Remarks
	R578	D0GA473JA021	47k	
	R579	ERJ2GEJ471	470	S
	R580	D0GA102JA021	1k	
	R581	ERJ2RKF2551	2.55k	
	R582	D0GA473JA021	47k	
	R583	D0GA104JA021	100k	
	R584	ERJ2RKF1502	15k	
	R585	D0GA562JA021	5.6k	
	R586	ERJ2GEJ563	56k	S
	R587	D0GA223JA015	22k	
	R588	D0GA223JA015	22k	
	R589	PQ4R10XJ332	3.3k	S
	R590	ERJ2GEJ563	56k	S
	R591	D0GA473JA021	47k	
	R592	D0GA473JA021	47k	
	R593	PQ4R10XJ332	3.3k	S
	R594	D0GA102JA021	1k	
	R595	D0GA562JA021	5.6k	
	R596	D0GA562JA021	5.6k	
	R598	D0GA562JA021	5.6k	
	R599	D0GA562JA021	5.6k	
	R600	ERJ12YJ680	68	
	R601	ERJ12YJ680	68	
	R602	D0GA473JA021	47k	
	R603	D0GA473JA021	47k	
	R604	D0GA472JA021	4.7k	
	R605	D0GB222JA057	2.2k	
	R606	D0GA562JA021	5.6k	
	R607	D0GB222JA057	2.2k	
	R608	D0GA473JA021	47k	
	R609	PQ4R18XJ121	120	S
	R611	D0GA183JA015	18k	
	R612	D0GA333JA015	33k	
	R613	ERJ2GEJ564	560k	
	R616	ERJ12YJ390H	39	S
	R619	D0GA103JA021	10k	
	R620	ERJ2GEJ563	56k	S
	R621	D0GA562JA021	5.6k	
	R622	D0GA473JA021	47k	
	R623	ERJ2RKF1503	150k	
	R624	ERJ2RKF2202X	22k	
	R627	PQ4R18XJ472	4.7k	S
	R629	D0GA102JA021	1k	
	R630	ERJ2RKF1503	150k	
	R632	D0GA562JA021	5.6k	
	R633	D0GA223JA015	22k	
	R634	D0GA562JA021	5.6k	
	R635	ERJ2GEJ563	56k	S
	R636	ERJ2GEYJ683	68k	S
	R637	D0GA103JA021	10k	
	R638	D0GA472JA021	4.7k	
	R640	ERJ2GEJ471	470	S
	R641	D0GA562JA021	5.6k	
	R642	ERJ2GEJ563	56k	S
	R643	ERJ2GEJ471	470	S
	R644	D0GA102JA021	1k	
	R645	ERJ2GEJ471	470	S
	R646	ERJ2GEJ563	56k	S
	R647	D0GA562JA021	5.6k	
	R648	ERJ2GEJ471	470	S
	R649	ERJ2GEJ471	470	S
	R650	ERJ2GEJ471	470	S
	R652	D0GA103JA021	10k	
	R655	ERJ2GEJ823	82k	S
	R656	D0GA473JA021	47k	
	R657	ERJ8GEYJ2R7	2.7	
	R658	ERJ8GEYJ2R7	2.7	
	R659	D0GA103JA021	10k	
	R660	D0GA183JA015	18k	
	R661	D0GA472JA021	4.7k	
	R662	D0GA183JA015	18k	
	R663	D0GA472JA021	4.7k	
	R664	D0GA103JA021	10k	

Safety	Ref. No.	Part No.	Part Name & Description	Remarks
	R665	D0GA473JA021	47k	
	R666	ERJ8RQFR56V	0.56	
	R667	ERJ8RQFR22	0.22	
	R669	ERJ8RQFR22	0.22	
	R670	ERJ8RQFR56V	0.56	
	R671	ERJ2GEYJ154	150k	S
	R672	ERJ2GEJ184	180k	S
	R673	D0GA473JA021	47k	
	R674	ERJ2GEJ101	100	S
	R683	D0GA103JA021	10k	
	R687	ERJ12YJ680	68	
	R688	ERJ12YJ680	68	
	R689	D0GA473JA021	47k	
	R690	D0GA473JA021	47k	
	R691	D0GB222JA057	2.2k	
	R692	D0GB222JA057	2.2k	
	R693	PQ4R18XJ121	120	S
	R694	D0GA472JA021	4.7k	
	R695	D0GA473JA021	47k	
	R696	D0GA183JA015	18k	
	R697	D0GA333JA015	33k	
	R701	ERJ2GEJ563	56k	S
	R702	ERJ2GEJ563	56k	S
	R703	ERJ2GEJ563	56k	S
	R704	D0GA562JA021	5.6k	
	R705	D0GA562JA021	5.6k	
	R706	D0GA562JA021	5.6k	
	R707	D0GA102JA021	1k	
	R708	D0GA473JA021	47k	
	R711	D0GA102JA021	1k	
	R712	D0GA473JA021	47k	
	R751	ERJ2RKF2491X	2.49k	
	R752	D0GA472JA021	4.7k	
	R755	D0GA472JA021	4.7k	
	R756	D0GA221JA021	220	
	R757	D0GA472JA021	4.7k	
	R758	D0GA472JA021	4.7k	
	R759	D0GA103JA021	10k	
	R767	D0GA220JA021	22	
	R771	D0GA472JA021	4.7k	
	R772	D0GA472JA021	4.7k	
	R773	D0GA472JA021	4.7k	
	R800	D0YBR0000020	0	
	R801	D0YBR0000020	0	
	R802	D0YBR0000020	0	
	R803	ERJ2RKF2212	22.1k	
	R804	ERJ2RKF2212	22.1k	
	R805	D0GB103JA057	10k	
	R806	ERJ2RKF7322	73.2k	
	R807	ERJ2GEJ512	5.1k	
	R808	ERJ2RKF1201	1.2k	
	R809	D0GA103JA021	10k	
	R810	D0YBR0000020	0	
	R811	ERJ2RKF1272	12.7k	
	R812	D0YBR0000020	0	
	R813	D0YBR0000020	0	
	R814	D0GA472JA021	4.7k	
	R815	D0GA103JA021	10k	
	R816	D0GA102JA021	1k	
	R817	D0GA103JA021	10k	
	R818	D0GA104JA021	100k	
	R819	D0GA102JA021	1k	
	R820	D0GA102JA021	1k	
	R821	D0GA273JA015	27k	
	R822	D0GA473JA021	47k	
	R823	D0YBR0000020	0	
	R825	D0GA273JA015	27k	
	R826	D0GA473JA021	47k	
	R828	ERJ2GEJ564	560k	
	R829	D0GA473JA021	47k	
	R830	D0GA474JA021	470k	
	R831	D0GA474JA021	470k	
	R832	D0GA474JA021	470k	

Safety	Ref. No.	Part No.	Part Name & Description	Remarks
	R833	D0GA104JA021	100k	
	R834	D0GA104JA021	100k	
	R835	D0GA103JA021	10k	
	R836	D0GA392JA015	3.9k	
	R837	D0GA472JA021	4.7k	
	R838	ERJ2GEJ471	470	S
	R839	D0GA104JA021	100k	
	R840	ERJ2RKF6341X	6.34k	
	R841	ERJ3GEYJ4R7	4.7	S
	R843	ERJ2RKF2200	220	
	R844	ERJ2RKF2200	220	
	R845	ERJ3GEYJ510	51	
	R846	ERJ2GEJ471	470	S
	R847	ERJ2GEJ471	470	S
	R851	D0GA103JA021	10k	
	R853	D0GA330JA015	33	
	R854	D0GA330JA015	33	
	L363	D0GA151JA021	150	
	L369	D0GA221JA021	220	
	L370	D0GA221JA021	220	
	L371	D0GA221JA021	220	
			(COMPONENTS PARTS)	
	RA305	EXB28V220JX	RESISTOR ARRAY	
	RA316	EXB28V470JX	RESISTOR ARRAY	
	RA321	EXB28V220JX	RESISTOR ARRAY	
	RA322	EXB28V220JX	RESISTOR ARRAY	
	RA323	EXB28V220JX	RESISTOR ARRAY	
	RA324	EXB28V220JX	RESISTOR ARRAY	
	RA400	EXB28V220JX	RESISTOR ARRAY	
	RA401	EXB28V220JX	RESISTOR ARRAY	
	RA402	EXB28V220JX	RESISTOR ARRAY	
	RA403	EXB28V220JX	RESISTOR ARRAY	
	RA404	EXB28V470JX	RESISTOR ARRAY	
	RA405	EXB28V470JX	RESISTOR ARRAY	
	RA406	EXB28V470JX	RESISTOR ARRAY	
	RA407	EXB28V220JX	RESISTOR ARRAY	
	RA408	EXB28V220JX	RESISTOR ARRAY	
	RA409	EXB28V220JX	RESISTOR ARRAY	
	RA410	EXB28V220JX	RESISTOR ARRAY	
	RA411	EXB28V470JX	RESISTOR ARRAY	
	RA412	EXB28V470JX	RESISTOR ARRAY	
	RA413	EXB28V470JX	RESISTOR ARRAY	
	RA414	EXB28V330	RESISTOR ARRAY	
	RA415	EXB28V330	RESISTOR ARRAY	
	RA416	EXB28V330	RESISTOR ARRAY	
	RA417	EXB28V330	RESISTOR ARRAY	
	RA418	EXB28V330	RESISTOR ARRAY	
	RA419	EXB28V330	RESISTOR ARRAY	
	RA420	EXB28V330	RESISTOR ARRAY	
	RA421	EXB28V330	RESISTOR ARRAY	
	RA422	EXB28V330	RESISTOR ARRAY	
	RA423	EXB28V330	RESISTOR ARRAY	
	RA424	EXB28V330	RESISTOR ARRAY	
	RA425	EXB28V103JX	RESISTOR ARRAY	
	RA426	EXB28V103JX	RESISTOR ARRAY	
	RA427	EXB28V103JX	RESISTOR ARRAY	
	RA428	EXB28V103JX	RESISTOR ARRAY	
	RA500	EXB28V470JX	RESISTOR ARRAY	
	RA501	EXB28V470JX	RESISTOR ARRAY	
	RA502	EXB28V470JX	RESISTOR ARRAY	
			(RELAY)	
△	RLY100	K6B1CYY00005	RELAY	
			(VARISTORS)	
△	SA100	PFRZRA102P6T	VARISTOR (SURGE ABSORBER)	S
△	SA101	PFRZRA102P6T	VARISTOR (SURGE ABSORBER)	S
	SA102	J0LY00000157	VARISTOR (SURGE ABSORBER)	
			(FUSES)	
	F100	K5G102A00041	FUSE	S
△	F600	K5H202Y00003	FUSE	
			(CRYSTAL OSCILLATORS)	
	X300	H0J240500074	CRYSTAL OSCILLATOR	
	X301	H0J245500124	CRYSTAL OSCILLATOR	
	X303	H0A327200186	CRYSTAL OSCILLATOR	

Safety	Ref. No.	Part No.	Part Name & Description	Remarks
	X500	H0J300500039	CRYSTAL OSCILLATOR	
	X750	H0J250500097	CRYSTAL OSCILLATOR	

18.2.5. Main Board (For KX-MB2575EU)

Safety	Ref. No.	Part No.	Part Name & Description	Remarks
	PCB1	PNWP1B2575EU	MAIN BOARD ASS'Y (RTL)	
			(ICs)	
	IC100	C1CB00002689	IC	
	IC101	C1CB00002690	IC	
	IC201	C1CB00001769	IC	
	IC203	C1AB00002556	IC	
	IC300	C1ZBZ0004649	IC	
	IC301	C0EBY0000665	IC	
	IC302	C0ZBZ0001747	IC	
	IC303	C0DBGY03947	IC	
	IC304	C0DBZY000592	IC	
	IC400	C3ABRY000078	IC	
	IC401	C3ABRY000078	IC	
	IC402	PNWI2575EU	IC (ROM)	
	IC403	C0JBAZ001466	IC	
	IC404	C0JBAZ001466	IC	
	IC405	C0JBAZ001539	IC	
	IC406	C0JBAZ001539	IC	
	IC407	C0JBAA000362	IC	
	IC500	C1ZBZ0003879	IC	
	IC502	AN44071A	IC	
	IC503	C0FBAY000092	IC	
	IC504	C0BBBA000024	IC	
	IC750	C1CB00003704	IC	
	IC800	C0DBAY01433	IC	
	IC801	C0DBAY01433	IC	
	IC802	C0DBAY00932	IC	
	IC803	C0DBEY00102	IC	
	IC850	C5ZBZ0000133	IC	
	IC851	C0ZBZ0001182	IC	
			(TRANSISTORS)	
	Q100	DSC710100L	TRANSISTOR (SI)	
	Q101	DSC710100L	TRANSISTOR (SI)	
	Q102	B1ABDP000005	TRANSISTOR (SI)	
	Q103	B1ABDP000005	TRANSISTOR (SI)	
	Q104	B1ADGP000008	TRANSISTOR (SI)	
	Q105	DRC9123J0L	TRANSISTOR (SI)	
	Q200	B1GBCFGN0005	TRANSISTOR (SI)	
	Q500	DSC9001R0L	TRANSISTOR (SI)	
	Q501	B1GBCFGN0005	TRANSISTOR (SI)	
	Q502	B1GBCFGN0005	TRANSISTOR (SI)	
	Q503	B1GBCFGN0005	TRANSISTOR (SI)	
	Q504	B1GBCFGN0005	TRANSISTOR (SI)	
	Q505	B1GBCFGN0005	TRANSISTOR (SI)	
	Q506	B1GBCFGN0005	TRANSISTOR (SI)	
	Q507	B1ABGE000014	TRANSISTOR (SI)	
	Q508	B1ADKE000002	TRANSISTOR (SI)	
	Q509	B1ADKE000002	TRANSISTOR (SI)	
	Q510	B1ABGE000014	TRANSISTOR (SI)	
	Q511	B1ABGE000014	TRANSISTOR (SI)	
	Q512	B1GBCFGN0005	TRANSISTOR (SI)	
	Q513	B1GBCFGN0005	TRANSISTOR (SI)	
	Q514	B1ABGE000011	TRANSISTOR (SI)	
	Q516	B1ABGE000011	TRANSISTOR (SI)	
	Q517	B1ABGE000011	TRANSISTOR (SI)	
	Q518	B1ADGE000012	TRANSISTOR (SI)	
	Q520	B1GBCFGN0005	TRANSISTOR (SI)	
	Q525	B1GBCFGN0005	TRANSISTOR (SI)	
	Q526	B1GBCFGN0005	TRANSISTOR (SI)	
	Q527	DRC9123J0L	TRANSISTOR (SI)	
	Q528	DSC9001R0L	TRANSISTOR (SI)	
	Q529	B1GBCFGN0005	TRANSISTOR (SI)	
	Q530	DSC9001R0L	TRANSISTOR (SI)	
	Q600	B1ADGE000012	TRANSISTOR (SI)	
	Q601	B1ADGE000012	TRANSISTOR (SI)	
	Q602	B1GBCFGN0005	TRANSISTOR (SI)	

Safety	Ref. No.	Part No.	Part Name & Description	Remarks
	Q603	B1ADGE000012	TRANSISTOR (SI)	
	Q604	B1ADCF000020	TRANSISTOR (SI)	
	Q605	DRA9143Z0L	TRANSISTOR (SI)	
	Q607	DSC9001R0L	TRANSISTOR (SI)	
	Q608	B1ADGE000012	TRANSISTOR (SI)	
	Q609	B1ADGE000012	TRANSISTOR (SI)	
	Q610	B1GBCFGN0005	TRANSISTOR (SI)	
	Q611	B1GBCFGN0005	TRANSISTOR (SI)	
	Q612	B1GBCFGN0005	TRANSISTOR (SI)	
	Q613	B1ADCF000020	TRANSISTOR (SI)	
	Q614	DRA9143Z0L	TRANSISTOR (SI)	
	Q650	B1ADCF000020	TRANSISTOR (SI)	
	Q651	DSC9001R0L	TRANSISTOR (SI)	
	Q700	B1ABGE000014	TRANSISTOR (SI)	
	Q701	B1ABGE000014	TRANSISTOR (SI)	
	Q702	B1GBCFGN0005	TRANSISTOR (SI)	
	Q703	DRA9143Z0L	TRANSISTOR (SI)	
	Q800	B1CHND000004	TRANSISTOR (SI)	
	Q801	B1GBCFGN0005	TRANSISTOR (SI)	
	Q802	B1CHND000004	TRANSISTOR (SI)	
	Q803	DRA9143Z0L	TRANSISTOR (SI)	
	Q804	DSC9001R0L	TRANSISTOR (SI)	
	Q805	DSC9001R0L	TRANSISTOR (SI)	
	Q806	B1GBCFGN0005	TRANSISTOR (SI)	
	Q807	B1CHQD000018	TRANSISTOR (SI)	
	Q808	B1CHQD000018	TRANSISTOR (SI)	
	Q809	B1ADCF000020	TRANSISTOR (SI)	
	Q810	DSC9001R0L	TRANSISTOR (SI)	
	Q812	B1GBCFGN0005	TRANSISTOR (SI)	
	Q813	B1CHQD000018	TRANSISTOR (SI)	
	Q814	B1ADCF000020	TRANSISTOR (SI)	
	Q815	B1GBCFGN0005	TRANSISTOR (SI)	
	Q850	B1GBCFGN0005	TRANSISTOR (SI)	
			(DIODES)	
	D100	DZ2W30000L	DIODE (SI)	
	D101	B0EDER000009	DIODE (SI)	
	D102	DA2J10100L	DIODE (SI)	
	D103	DZ2J056M0L	DIODE (SI)	
	D104	DZ2J056M0L	DIODE (SI)	
	D301	DD2S06200L	DIODE (SI)	
	D302	DD2S06200L	DIODE (SI)	
	D306	B0ZBZ0000146	DIODE (SI)	
	D600	DA2J10100L	DIODE (SI)	
	D601	DA2J10100L	DIODE (SI)	
	D801	DZ2W05600L	DIODE (SI)	S
	D803	DZ2W05600L	DIODE (SI)	S
	D804	B0JCND000031	DIODE (SI)	
	D805	B0BC6R5A0541	DIODE (SI)	
	D806	FJVDJADAN202	DIODE (SI)	S
	D807	DA2J10100L	DIODE (SI)	
	DA300	B0ADEJ000025	DIODE (SI)	
	LED750	B3ABB0000331	DIODE (SI)	
			(BATTERY)	
	BAT300	BR2032/1HF1	BATTERY	S
			(CAPACITORS)	
	C100	ECUE1C103KBQ	0.01	S
	C101	ECUE1A104KBQ	0.1	S
	C102	ECUE1A104KBQ	0.1	S
⚠	C103	F1BAF330A048	33p	
⚠	C104	F1BAF330A048	33p	
	C105	EEE1HA010SR	1	
	C106	ECUE1A104KBQ	0.1	S
	C107	ECUE1A104KBQ	0.1	S
	C108	F1J2E121A023	0.00012	
	C109	F1J2E121A023	0.00012	
	C110	F1G1H272A571	0.0027	
	C111	ECUE1C103KBQ	0.01	S
	C112	ECUE1C103KBQ	0.01	S
	C113	F1J2E1030004	0.01	
	C114	F1G1H101A557	0.0001	
	C115	F0C2E1050004	1	
⚠	C116	F1BAF471A049	470p	
⚠	C117	F1BAF471A049	470	

Safety	Ref. No.	Part No.	Part Name & Description	Remarks
△	C119	F1BAF330A048	33p	
	C203	ECUE1C103KBQ	0.01	s
	C204	ECUE1A104KBQ	0.1	s
	C206	ECUE1C223KBQ	0.022	s
	C207	ECUE1A104KBQ	0.1	s
	C209	ECUE1A104KBQ	0.1	s
	C211	ECUE1A104KBQ	0.1	s
	C212	ECUE1C223KBQ	0.022	s
	C226	FIG0J105A007	10	
	C227	FIG0J105A007	10	
	C229	ECJ0EB1H392K	0.0039	
	C232	FLJ0J2260004	220	
	C300	ECUE1A104KBQ	0.1	s
	C301	ECUE1C103KBQ	0.01	s
	C302	ECUE1A104KBQ	0.1	s
	C303	ECUE1A104KBQ	0.1	s
	C304	ECUE1A104KBQ	0.1	s
	C305	ECUE1A104KBQ	0.1	s
	C306	ECUE1A104KBQ	0.1	s
	C307	ECUE1A104KBQ	0.1	s
	C308	FIG0J105A007	10	
	C309	FIG1A273A032	0.27	
	C310	FIG1H100A565	1p	
	C311	FIG1H180A565	18p	
	C312	ECUE1A104KBQ	0.1	s
	C313	FIG1H180A565	18p	
	C314	FIG1H180A565	18p	
	C319	FIG0J105A007	10	
	C322	ECUE1A104KBQ	0.1	s
	C325	FIG0J105A007	10	
	C326	ECUE1C103KBQ	0.01	s
	C327	ECUE1A104KBQ	0.1	s
	C328	FIG0J224A044	0.22	
	C329	FIG0J224A044	0.22	
	C330	FIH0J105A037	1	
	C331	FIH0J105A037	1	
	C340	ECUE1A104KBQ	0.1	s
	C341	ECUE1A104KBQ	0.1	s
	C342	ECUE1A104KBQ	0.1	s
	C343	ECUE1A104KBQ	0.1	s
	C344	ECUE1C103KBQ	0.01	s
	C351	FIG1H101A557	0.0001	
	C356	ECUE1A104KBQ	0.1	s
	C357	ECUE1A104KBQ	0.1	s
	C358	ECUE1A104KBQ	0.1	s
	C359	ECUE1A104KBQ	0.1	s
	C360	ECUE1A104KBQ	0.1	s
	C361	ECUE1A104KBQ	0.1	s
	C362	ECUE1A104KBQ	0.1	s
	C363	ECUE1A104KBQ	0.1	s
	C364	ECUE1A104KBQ	0.1	s
	C365	ECUE1H102KBQ	0.001	s
	C366	ECUE1A104KBQ	0.1	s
	C367	FIG0J105A007	10	
	C368	FIG0J105A007	10	
	C369	FIG0J105A007	10	
	C370	FIH1A105A025	1	
	C371	FIH0J1060006	10	
	C400	FIH0J105A037	1	
	C401	FIH0J105A037	1	
	C402	FIH0J105A037	1	
	C403	FIH0J105A037	1	
	C404	FIH0J105A037	1	
	C405	FIH0J105A037	1	
	C406	FIH0J105A037	1	
	C407	FIH0J105A037	1	
	C408	ECUE1A104KBQ	0.1	s
	C409	ECUE1A104KBQ	0.1	s
	C410	ECUE1A104KBQ	0.1	s
	C411	ECUE1A104KBQ	0.1	s
	C412	ECUE1A104KBQ	0.1	s
	C413	ECUE1A104KBQ	0.1	s
	C414	ECUE1A104KBQ	0.1	s

Safety	Ref. No.	Part No.	Part Name & Description	Remarks
	C440	ECUE1A104KBQ	0.1	s
	C441	ECUE1A104KBQ	0.1	s
	C442	ECUE1A104KBQ	0.1	s
	C443	ECUE1A104KBQ	0.1	s
	C444	ECUE1A104KBQ	0.1	s
	C445	ECUE1A104KBQ	0.1	s
	C446	ECUE1A104KBQ	0.1	s
	C447	ECUE1A104KBQ	0.1	s
	C448	ECUE1A104KBQ	0.1	s
	C449	ECUE1A104KBQ	0.1	s
	C450	ECUE1A104KBQ	0.1	s
	C451	ECUE1A104KBQ	0.1	s
	C452	ECUE1A104KBQ	0.1	s
	C453	ECUE1A104KBQ	0.1	s
	C454	ECUE1A104KBQ	0.1	s
	C455	ECUE1A104KBQ	0.1	s
	C456	ECUE1A104KBQ	0.1	s
	C457	ECUE1A104KBQ	0.1	s
	C458	ECUE1A104KBQ	0.1	s
	C459	ECUE1A104KBQ	0.1	s
	C460	ECUE1A104KBQ	0.1	s
	C461	ECUE1A104KBQ	0.1	s
	C462	ECUE1A104KBQ	0.1	s
	C463	ECUE1A104KBQ	0.1	s
	C464	ECUE1A104KBQ	0.1	s
	C465	ECUE1A104KBQ	0.1	s
	C466	ECUE1A104KBQ	0.1	s
	C467	ECUE1A104KBQ	0.1	s
	C468	ECUE1A104KBQ	0.1	s
	C469	ECUE1A104KBQ	0.1	s
	C470	ECUE1A104KBQ	0.1	s
	C471	ECUE1A104KBQ	0.1	s
	C472	ECUE1A104KBQ	0.1	s
	C473	ECUE1A104KBQ	0.1	s
	C474	ECUE1A104KBQ	0.1	s
	C475	ECUE1A104KBQ	0.1	s
	C476	ECUE1A104KBQ	0.1	s
	C477	ECUE1A104KBQ	0.1	s
	C478	ECUE1A104KBQ	0.1	s
	C479	ECUE1A104KBQ	0.1	s
	C485	FIH1H104A220	0.1	
	C486	FIH1H104A220	0.1	
	C487	FIH1H104A220	0.1	
	C488	FIH1H104A220	0.1	
	C489	FIH1H104A220	0.1	
	C490	FIH1H104A220	0.1	
	C491	FIH1H104A220	0.1	
	C492	FIH1H104A220	0.1	
	C493	FIH1H104A220	0.1	
	C494	FIH1H104A220	0.1	
	C495	FIH1H104A220	0.1	
	C496	FIH1H104A220	0.1	
	C497	FIH1H104A220	0.1	
	C498	FIH1H104A220	0.1	
	C499	FIH1H104A220	0.1	
	C500	ECUE1H8R0DCQ	8	
	C501	FIG1H220A565	22p	
	C503	ECUE1A104KBQ	0.1	s
	C504	ECUE1C103KBQ	0.01	s
	C505	ECUE1H181JCQ	180p	s
	C506	ECUE1H181JCQ	180p	s
	C507	ECUE1H102KBQ	0.001	s
	C508	ECJ0EB1A473K	0.047	s
	C509	ECUE1H181JCQ	180p	s
	C510	ECUE1A104KBQ	0.1	s
	C511	ECUE1A104KBQ	0.1	s
	C512	ECUE1A104KBQ	0.1	s
	C513	ECUE1A104KBQ	0.1	s
	C514	ECUE1A104KBQ	0.1	s
	C515	ECUE1H181JCQ	180p	s
	C516	ECUE1H102KBQ	0.001	s
	C517	ECUE1A104KBQ	0.1	s
	C518	FIH1H104A220	0.1	

Safety	Ref. No.	Part No.	Part Name & Description	Remarks
	C519	ECUE1A104KBQ	0.1	S
	C520	ECUE1H181JCQ	180p	S
	C522	ECUE1A104KBQ	0.1	S
	C523	ECUE1H181JCQ	180p	S
	C524	F1G1H220A565	22p	
	C525	ECUE1H102KBQ	0.001	S
	C526	ECUE1H102KBQ	0.001	S
	C527	ECUE1H102KBQ	0.001	S
	C528	ECUE1H102KBQ	0.001	S
	C529	ECUE1H102KBQ	0.001	S
	C530	ECUE1A104KBQ	0.1	S
	C531	F1J1A106A024	10	
	C532	ECUE1H181JCQ	180p	S
	C533	ECUE1A104KBQ	0.1	S
	C534	ECUE1A104KBQ	0.1	S
	C535	ECUE1H102KBQ	0.001	S
	C536	ECUE1A104KBQ	0.1	S
	C537	ECUE1A104KBQ	0.1	S
	C538	F1G0J105A007	10	
	C539	ECUE1H102KBQ	0.001	S
	C540	ECUE1A104KBQ	0.1	S
	C541	ECUE1H102KBQ	0.001	S
	C542	ECUE1H181JCQ	180p	S
	C543	ECUE1A104KBQ	0.1	S
	C544	ECUE1C103KBQ	0.01	S
	C545	F1G0J105A007	10	
	C546	ECUE1C103KBQ	0.01	S
	C548	ECUE1H102KBQ	0.001	S
	C549	EEEEJA101WR	100	
	C551	ECUE1H102KBQ	0.001	S
	C552	F1H1H104A220	0.1	
	C553	ECUE1H102KBQ	0.001	S
	C554	ECUE1H102KBQ	0.001	S
	C555	ECUE1A104KBQ	0.1	S
	C556	ECUV0J474KBV	0.47	
	C557	ECUE1H181JCQ	180p	S
	C558	ECUE1H102KBQ	0.001	S
	C559	ECUE1H102KBQ	0.001	S
	C561	ECUE1H102KBQ	0.001	S
	C562	ECUE1H102KBQ	0.001	S
	C563	ECUE1H102KBQ	0.001	S
	C565	ECJOEB1A473K	0.047	S
	C569	ECJOEB1A473K	0.047	S
	C571	ECUE1A104KBQ	0.1	S
	C572	F1G0J105A007	10	
	C576	ECUE1A104KBQ	0.1	S
	C577	ECUE1H102KBQ	0.001	S
	C600	ECUE1H102KBQ	0.001	S
	C601	ECUE1H102KBQ	0.001	S
	C613	F2G1V1010021	100	
	C615	F1G1H101A557	0.0001	
	C618	F1G0J105A007	10	
	C619	ECUE1H102KBQ	0.001	S
	C620	ECUE1H102KBQ	0.001	S
	C621	ECUE1H102KBQ	0.001	S
	C622	ECUE1H102KBQ	0.001	S
	C623	ECUE1H102KBQ	0.001	S
	C624	ECUE1H102KBQ	0.001	S
	C625	ECUE1H102KBQ	0.001	S
	C626	F1H1H104A220	0.1	
	C627	ECUE1H102KBQ	0.001	S
	C628	ECUE1H102KBQ	0.001	S
	C650	ECUE1C103KBQ	0.01	S
	C652	F1G0J105A007	10	
	C654	ECUE1A104KBQ	0.1	S
	C655	ECUE1H103ZFQ	0.01	S
	C656	ECUE1H103ZFQ	0.01	S
	C657	ECUE1A104KBQ	0.1	S
	C700	ECUE1C103KBQ	0.01	S
	C701	ECUE1H102KBQ	0.001	S
	C702	ECUE1H102KBQ	0.001	S
	C703	ECUE1H102KBQ	0.001	S
	C709	ECUE1H222KBQ	0.0022	S

Safety	Ref. No.	Part No.	Part Name & Description	Remarks
	C710	ECUE1H222KBQ	0.0022	S
	C711	ECUE1H222KBQ	0.0022	S
	C712	ECUE1H222KBQ	0.0022	S
	C751	ECUE1A104KBQ	0.1	S
	C752	F1J1C106A191	10	
	C753	ECUE1A104KBQ	0.1	S
	C754	ECUE1C103KBQ	0.01	S
	C755	ECUE1C103KBQ	0.01	S
	C756	ECUE1H070DCQ	7p	S
	C757	ECJ0EC1H120J	12p	S
	C758	ECUE1A104KBQ	0.1	S
	C759	ECUE1A104KBQ	0.1	S
	C760	ECUE1A104KBQ	0.1	S
	C761	ECUE1A104KBQ	0.1	S
	C762	F1J1C106A191	10	
	C763	ECUE1A104KBQ	0.1	S
	C764	ECUE1A104KBQ	0.1	S
	C765	ECUE1A104KBQ	0.1	S
	C766	ECUE1A104KBQ	0.1	S
	C767	ECUE1A104KBQ	0.1	S
	C768	F1G1H100A565	1p	
	C800	F1G0J105A007	10	
	C801	F1K1E1060004	10	
	C802	F1H1H104A220	0.1	
	C803	ECUE1A104KBQ	0.1	S
	C804	F1G0J105A007	10	
	C805	F1G1E472A086	0.0047	
	C806	F1G1H100A565	1p	
	C807	F1K0J476A009	47	
	C808	F1K1E1060004	10	
	C809	F1H1H104A220	0.1	
	C810	ECUE1A104KBQ	0.1	S
	C811	F1H1H104A220	0.1	
	C813	F1G0J105A007	10	
	C814	F1G1E472A086	0.0047	
	C815	F2G1V4700028	47	
	C816	F1K0J476A009	47	
	C817	F1H1C105A118	1	
	C818	F1H1C105A118	1	
	C819	F1K1E1060004	10	
	C820	F1H1H104A220	0.1	
	C822	F1J1C475A059	4.7	
	C823	ECUE1H102KBQ	0.001	S
	C824	ECUE1H102KBQ	0.001	S
	C826	ECUE1H102KBQ	0.001	S
	C829	F1J1A106A024	10	
	C830	F1G0J105A007	10	
	C831	F1J1A106A024	10	
	C832	F1J1C475A059	4.7	
	C833	F1H1H104A220	0.1	
	C834	F2G1V4700028	47	
	C835	F1J1A106A024	10	
	C836	F1J1A106A024	10	
	C837	F1H1H104A748	0.1	
	C853	F1L0J476A017	47	
	C854	F1G1H101A557	0.0001	
	C855	F1J0J2260004	220	
	C856	F1J0J2260004	220	
	C857	ECUE1A104KBQ	0.1	S
	C858	F1J0J2260004	220	
	C859	ECUE1H102KBQ	0.001	S
	C860	ECUE1H102KBQ	0.001	S
	C861	F1G1H101A557	0.0001	
	C862	F1G1H101A557	0.0001	
	C863	ECUE1H471KBQ	470p	S
			(CONNECTORS AND JACKS)	
	CN100	K2LB106B0053	JACK/SOCKET	
	CN101	K2LB106B0053	JACK/SOCKET	
	CN201	K1KA02A00587	CONNECTOR, 2PIN	
	CN300	K1FY104B0015	CONNECTOR, 4PIN	
	CN301	K1KA05AA0193	CONNECTOR, 5PIN	
	CN500	K1KA09A00236	CONNECTOR, 9PIN	
	CN501	K1KA05A00364	CONNECTOR, 5PIN	

Safety	Ref. No.	Part No.	Part Name & Description	Remarks
	CN503	K1KA04A00527	CONNECTOR, 4PIN	
	CN504	K1KA10A00412	CONNECTOR, 10PIN	
	CN505	K1KA07A00257	CONNECTOR, 7PIN	
	CN506	K1KA02A00587	CONNECTOR, 2PIN	
	CN507	K1KA06A00428	CONNECTOR, 6PIN	
	CN508	K1KA02A00745	CONNECTOR, 2PIN	
	CN509	K1KA06A00499	CONNECTOR, 4PIN	
	CN510	K1KA04A00527	CONNECTOR, 4PIN	
	CN511	K1KA06A00428	CONNECTOR, 6PIN	
	CN513	K1MY12AA0238	CONNECTOR, 12PIN	
	CN514	K1KA11A00158	CONNECTOR, 11PIN	
	CN515	K1KA08A00440	CONNECTOR, 8PIN	
	CN516	K1KA04AA0193	CONNECTOR, 4PIN	
	CN517	K1KA08A00440	CONNECTOR, 8PIN	
	CN518	K1KA08AA0193	CONNECTOR, 8PIN	
	CN519	K1KA03A00612	CONNECTOR, 3PIN	
	CN700	K1KA12A00315	CONNECTOR, 12PIN	
	CN750	K2LC108B0112	JACK/SOCKET	
	CN800	K1KA03A00495	CONNECTOR, 3PIN	
			(COILS)	
	L104	PQLQR2BT	COIL	S
	L105	PQLQR2BT	COIL	S
	L106	PQLQR2BT	COIL	S
	L107	PQLQR2BT	COIL	S
	L108	PQLQR2BT	COIL	S
	L109	PQLQR2BT	COIL	S
	L110	G0B862C00003	COIL	
	L300	G1BYYC00026	COIL	
	L301	G1BYYC00026	COIL	
	L305	G1BYYC00026	COIL	
	L306	G1BYYC00026	COIL	
	L372	J0JCC0000278	COIL	
	L508	PFVF2P221SG	COIL	S
	L511	PQLQR2KB113T	COIL	S
	L752	G1BYYYY00010	COIL	
	L753	G1BYYYY00010	COIL	
	L800	G1C4R7MA0445	COIL	
	L801	G1C2R2MA0395	COIL	
	L802	G1C4R7MA0445	COIL	
			(IC FILTERS)	
	L100	J0JCC0000002	IC FILTER	
	L101	J0JCC0000002	IC FILTER	
	L102	J0JBC0000040	IC FILTER	
	L103	J0JBC0000040	IC FILTER	
	L210	J0JCC0000288	IC FILTER	
	L211	J0JCC0000288	IC FILTER	
	L214	J0JCC0000276	IC FILTER	
	L302	J0JCC0000308	IC FILTER	
	L303	J0JCC0000308	IC FILTER	
	L304	J0JAC0000059	IC FILTER	
	L307	J0JYC0000070	IC FILTER	
	L344	J0JCC0000286	IC FILTER	
	L345	J0JCC0000286	IC FILTER	
	L346	J0JCC0000286	IC FILTER	
	L347	J0JCC0000286	IC FILTER	
	L348	J0JCC0000277	IC FILTER	
	L349	J0JCC0000277	IC FILTER	
	L350	J0JCC0000277	IC FILTER	
	L351	J0JCC0000277	IC FILTER	
	L352	J0JCC0000277	IC FILTER	
	L353	J0JCC0000277	IC FILTER	
	L354	J0JCC0000277	IC FILTER	
	L355	J0JCC0000277	IC FILTER	
	L356	J0JCC0000413	IC FILTER	
	L357	J0MAB0000144	IC FILTER	
	L358	J0JCC0000277	IC FILTER	
	L359	J0JCC0000277	IC FILTER	
	L360	J0JCC0000276	IC FILTER	
	L361	J0JCC0000275	IC FILTER	
	L362	J0JCC0000276	IC FILTER	
	L364	J0JCC0000274	IC FILTER	
	L365	J0JCC0000286	IC FILTER	
	L504	J0HAAB000002	IC FILTER	

Safety	Ref. No.	Part No.	Part Name & Description	Remarks
	L506	J0JCC0000276	IC FILTER	
	L507	J0JCC0000276	IC FILTER	
	L509	J0JAC0000059	IC FILTER	
	L510	J0JCC0000276	IC FILTER	
	L750	J0JCC0000276	IC FILTER	
	L751	J0JCC0000251	IC FILTER	
	R559	J0JCC0000276	IC FILTER	
	R750	J0JCC0000308	IC FILTER	
			(RESISTORS)	
	R100	D0GA473JA021	47k	
	R102	D0GB560JA057	56	
	R103	D0GB560JA057	56	
	R104	ERJ2RKF1004	1m	
	R105	ERJ12SF1071	1m	
	R106	ERJ6GEYJ515	5.1m	
	R107	ERJ6GEYJ515	5.1m	
	R108	ERJ12SF3651	3.65k	
	R109	D0GF156JA051	15m	
	R110	D0GF156JA051	15m	
	R111	D0GA151JA021	150	
	R112	ERJ8ENF5360	536	
	R113	ERJ12SF73R2	73.2	
	R114	ERJ12SF2491	2.49k	
	R115	D0GA104JA021	100k	
	R116	D0GA104JA021	100k	
	R117	ERDS1TJ223	22k	S
	R119	ERG1SJ120E	12	
	R121	D0GA103JA021	10k	
	R122	PQ4R18XJ100	10	S
	R200	D0YBR0000020	0	
	R204	D0YBR0000020	0	
	R205	D0YBR0000020	0	
	R206	D0GA473JA021	47k	
	R207	D0GA332JA015	3.3k	
	R212	D0GA472JA021	4.7k	
	R213	D0GA103JA021	10k	
	R215	D0GA105JA021	1m	
	R216	D0GA472JA021	4.7k	
	R227	D0GA102JA021	1k	
	R229	D0GA273JA015	27k	
	R233	PQ4R18XJ100	10	S
	R234	ERJ2GEYJ154	150k	S
	R235	D0GA124JA015	120k	
	R302	D0GA103JA021	10k	
	R303	D0GA103JA021	10k	
	R304	ERJ2GEJ101	100	S
	R305	D0GA103JA021	10k	
	R306	D0GA102JA021	1k	
	R307	D0GA103JA021	10k	
	R309	ERJ2RKF3301	3.3k	
	R310	ERJ2RKF6801	6.8k	
	R311	ERJ2GE0R00	0	S
	R312	ERJ2GE0R00	0	S
	R313	ERJ2GE0R00	0	S
	R314	ERJ2GE0R00	0	S
	R315	D0GA103JA021	10k	
	R316	D0GA103JA021	10k	
	R317	D0GA470JA021	47	
	R318	D0GA470JA021	47	
	R319	D0GA104JA021	100k	
	R320	ERJ2RKF1212	12.1k	
	R321	D0GA103JA021	10k	
	R322	ERJ2RKF1212	12.1k	
	R323	D0GA103JA021	10k	
	R324	ERJ2RKF1212	12.1k	
	R325	D0GA103JA021	10k	
	R327	ERJ2GE0R00	0	S
	R329	ERJ2GE0R00	0	S
	R331	ERJ2GE0R00	0	S
	R332	ERJ2GE0R00	0	S
	R335	ERJ2GE0R00	0	S
	R338	D0GA103JA021	10k	
	R339	ERJ2GEJ823	82k	S

Safety	Ref. No.	Part No.	Part Name & Description	Remarks
	R345	D0GA103JA021	10k	
	R346	D0GA152JA021	1.5k	
	R347	D0YBR0000020	0	
	R348	D0YBR0000020	0	
	R352	D0GA103JA021	10k	
	R354	D0GA103JA021	10k	
	R355	D0GA103JA021	10k	
	R356	ERJ3GEYJ6R8	6.8	
	R357	ERJ3GEYJ6R8	6.8	
	R359	D0GA104JA021	100k	
	R360	D0GA103JA021	10k	
	R362	D0GA103JA021	10k	
	R364	D0GA103JA021	10k	
	R366	D0GA470JA021	47	
	R367	D0GA151JA021	150	
	R368	D0GA151JA021	150	
	R369	D0GA151JA021	150	
	R370	D0GA104JA021	100k	
	R371	D0GA103JA021	10k	
	R372	D0GA103JA021	10k	
	R373	D0GA103JA021	10k	
	R377	D0GA103JA021	10k	
	R379	D0GA470JA021	47	
	R382	ERJ2GEOR00	0	S
	R383	ERJ2GEOR00	0	S
	R384	ERJ2GEJ101	100	S
	R385	D0GA105JA021	1m	
	R386	D0GA151JA021	150	
	R387	D0GA470JA021	47	
	R388	ERJ2GEYJ683	68k	S
	R389	D0GA102JA021	1k	
	R391	D0GA103JA021	10k	
	R395	D0GA470JA021	47	
	R399	D0GA103JA021	10k	
	R400	D0GA470JA021	47	
	R401	D0GA680JA015	68	
	R402	D0GA470JA021	47	
	R403	D0GA470JA021	47	
	R404	D0GA470JA021	47	
	R405	D0GA470JA021	47	
	R406	D0GA470JA021	47	
	R407	D0GA470JA021	47	
	R408	D0GA470JA021	47	
	R409	D0GA560JA015	56	
	R410	D0GA680JA015	68	
	R411	D0GA680JA015	68	
	R412	D0GA470JA021	47	
	R413	D0GA470JA021	47	
	R414	D0GA470JA021	47	
	R415	D0GA470JA021	47	
	R416	D0GA470JA021	47	
	R417	D0GA470JA021	47	
	R418	D0GA470JA021	47	
	R419	D0GA560JA015	56	
	R420	D0GA680JA015	68	
	R421	D0GA470JA021	47	
	R422	D0GA330JA015	33	
	R423	D0GA103JA021	10k	
	R424	D0GA103JA021	10k	
	R425	ERJ2GEJ820	82	S
	R450	D0GA103JA021	10k	
	R451	D0GA103JA021	10k	
	R495	D0YBR0000020	0	
	R496	D0YBR0000020	0	
	R497	D0YBR0000020	0	
	R498	D0YBR0000020	0	
	R500	D0GA220JA021	22	
	R501	ERJ2GEJ101	100	S
	R502	ERJ2GEJ101	100	S
	R503	ERJ2RKF1502	15k	
	R504	D0GA473JA021	47k	
	R505	ERJ2RKF3012	30.1k	
	R506	D0GA223JA015	22k	

Safety	Ref. No.	Part No.	Part Name & Description	Remarks
	R507	D0GA221JA021	220	
	R508	D0GA330JA015	33	
	R509	D0GA102JA021	1k	
	R510	D0GA562JA021	5.6k	
	R511	D0GA105JA021	1m	
	R512	ERJ2GEJ563	56k	S
	R515	D0GA102JA021	1k	
	R516	ERJ2GEJ622X	6.2k	
	R517	D0GA103JA021	10k	
	R518	D0GA472JA021	4.7k	
	R519	D0GA103JA021	10k	
	R520	D0GA103JA021	10k	
	R521	D0GA470JA021	47	
	R522	ERJ3GEYJ6R8	6.8	
	R523	ERJ2GEJ563	56k	S
	R524	ERJ2GEOR00	0	S
	R525	ERJ2GEOR00	0	S
	R526	D0GA330JA015	33	
	R527	D0GA562JA021	5.6k	
	R528	D0GA330JA015	33	
	R529	ERJ2GEOR00	0	S
	R530	ERJ2GEJ471	470	S
	R531	D0GA330JA015	33	
	R533	D0GA473JA021	47k	
	R534	D0GA222JA021	2.2k	
	R535	D0GA473JA021	47k	
	R536	D0GA474JA021	470k	
	R537	D0GA473JA021	47k	
	R538	D0GA152JA021	1.5k	
	R539	D0GA182JA015	1.8k	
	R541	ERJ2GEYJ331	330	S
	R542	D0GA681JA021	680	
	R543	ERJ3GEYJ390	39	
	R544	ERJ2GEYJ331	330	S
	R545	D0GA330JA015	33	
	R546	D0GA681JA021	680	
	R547	D0GA330JA015	33	
	R548	D0GA330JA015	33	
	R549	D0GB560JA057	56	
	R550	ERJ2GEYJ331	330	S
	R551	D0GA473JA021	47k	
	R552	D0GA102JA021	1k	
	R553	D0GA181JA021	180	
	R554	D0GA681JA021	680	
	R555	D0GA472JA021	4.7k	
	R556	ERJ3GEYJ680	68	S
	R557	D0GA473JA021	47k	
	R558	D0GA102JA021	1k	
	R560	D0GA181JA021	180	
	R561	D0GA102JA021	1k	
	R562	D0GA102JA021	1k	
	R563	ERJ2GEJ101	100	S
	R564	ERJ2RKF1802	18k	
	R566	ERJ2GEJ563	56k	S
	R567	D0GA103JA021	10k	
	R568	ERJ2RKF3902	39k	
	R569	D0GA473JA021	47k	
	R570	D0GA102JA021	1k	
	R571	ERJ2GEJ563	56k	S
	R574	D0GA103JA021	10k	
	R575	ERJ2GEJ564	560k	
	R576	D0GA104JA021	100k	
	R577	D0GA472JA021	4.7k	
	R578	D0GA473JA021	47k	
	R579	ERJ2GEJ471	470	S
	R580	D0GA102JA021	1k	
	R581	ERJ2RKF2551	2.55k	
	R582	D0GA473JA021	47k	
	R583	D0GA104JA021	100k	
	R584	ERJ2RKF1502	15k	
	R585	D0GA562JA021	5.6k	
	R586	ERJ2GEJ563	56k	S
	R587	D0GA223JA015	22k	

Safety	Ref. No.	Part No.	Part Name & Description	Remarks
	R588	D0GA223JA015	22k	
	R589	PQ4R10XJ332	3.3k	S
	R590	ERJ2GEJ563	56k	S
	R591	D0GA473JA021	47k	
	R592	D0GA473JA021	47k	
	R593	PQ4R10XJ332	3.3k	S
	R594	D0GA102JA021	1k	
	R595	D0GA562JA021	5.6k	
	R596	D0GA562JA021	5.6k	
	R598	D0GA562JA021	5.6k	
	R599	D0GA562JA021	5.6k	
	R600	ERJ12YJ680	68	
	R601	ERJ12YJ680	68	
	R602	D0GA473JA021	47k	
	R603	D0GA473JA021	47k	
	R604	D0GA472JA021	4.7k	
	R605	D0GB222JA057	2.2k	
	R606	D0GA562JA021	5.6k	
	R607	D0GB222JA057	2.2k	
	R608	D0GA473JA021	47k	
	R609	PQ4R18XJ121	120	S
	R611	D0GA183JA015	18k	
	R612	D0GA333JA015	33k	
	R613	ERJ2GEJ564	560k	
	R616	ERJ12YJ390H	39	S
	R619	D0GA103JA021	10k	
	R620	ERJ2GEJ563	56k	S
	R621	D0GA562JA021	5.6k	
	R622	D0GA473JA021	47k	
	R623	ERJ2RKF1503	150k	
	R624	ERJ2RKF2202X	22k	
	R627	PQ4R18XJ472	4.7k	S
	R629	D0GA102JA021	1k	
	R630	ERJ2RKF1503	150k	
	R632	D0GA562JA021	5.6k	
	R633	D0GA223JA015	22k	
	R634	D0GA562JA021	5.6k	
	R635	ERJ2GEJ563	56k	S
	R636	ERJ2GEYJ683	68k	S
	R637	D0GA103JA021	10k	
	R638	D0GA472JA021	4.7k	
	R640	ERJ2GEJ471	470	S
	R641	D0GA562JA021	5.6k	
	R642	ERJ2GEJ563	56k	S
	R643	ERJ2GEJ471	470	S
	R644	D0GA102JA021	1k	
	R645	ERJ2GEJ471	470	S
	R646	ERJ2GEJ563	56k	S
	R647	D0GA562JA021	5.6k	
	R648	ERJ2GEJ471	470	S
	R649	ERJ2GEJ471	470	S
	R650	ERJ2GEJ471	470	S
	R652	D0GA103JA021	10k	
	R655	ERJ2GEJ823	82k	S
	R656	D0GA473JA021	47k	
	R657	ERJ8GEYJ2R7	2.7	
	R658	ERJ8GEYJ2R7	2.7	
	R659	D0GA103JA021	10k	
	R660	D0GA183JA015	18k	
	R661	D0GA472JA021	4.7k	
	R662	D0GA183JA015	18k	
	R663	D0GA472JA021	4.7k	
	R664	D0GA103JA021	10k	
	R665	D0GA473JA021	47k	
	R666	ERJ8RQFR56V	0.56	
	R667	ERJ8RQFR22	0.22	
	R669	ERJ8RQFR22	0.22	
	R670	ERJ8RQFR56V	0.56	
	R671	ERJ2GEYJ154	150k	S
	R672	ERJ2GEJ184	180k	S
	R673	D0GA473JA021	47k	
	R674	ERJ2GEJ101	100	S
	R683	D0GA103JA021	10k	

Safety	Ref. No.	Part No.	Part Name & Description	Remarks
	R687	ERJ12YJ680	68	
	R688	ERJ12YJ680	68	
	R689	D0GA473JA021	47k	
	R690	D0GA473JA021	47k	
	R691	D0GB222JA057	2.2k	
	R692	D0GB222JA057	2.2k	
	R693	PQ4R18XJ121	120	S
	R694	D0GA472JA021	4.7k	
	R695	D0GA473JA021	47k	
	R696	D0GA183JA015	18k	
	R697	D0GA333JA015	33k	
	R701	ERJ2GEJ563	56k	S
	R702	ERJ2GEJ563	56k	S
	R703	ERJ2GEJ563	56k	S
	R704	D0GA562JA021	5.6k	
	R705	D0GA562JA021	5.6k	
	R706	D0GA562JA021	5.6k	
	R707	D0GA102JA021	1k	
	R708	D0GA473JA021	47k	
	R711	D0GA102JA021	1k	
	R712	D0GA473JA021	47k	
	R751	ERJ2RKF2491X	2.49k	
	R752	D0GA472JA021	4.7k	
	R755	D0GA472JA021	4.7k	
	R756	D0GA221JA021	220	
	R757	D0GA472JA021	4.7k	
	R758	D0GA472JA021	4.7k	
	R759	D0GA103JA021	10k	
	R767	D0GA220JA021	22	
	R771	D0GA472JA021	4.7k	
	R772	D0GA472JA021	4.7k	
	R773	D0GA472JA021	4.7k	
	R800	D0YBR0000020	0	
	R801	D0YBR0000020	0	
	R802	D0YBR0000020	0	
	R803	ERJ2RKF2212	22.1k	
	R804	ERJ2RKF2212	22.1k	
	R805	D0GB103JA057	10k	
	R806	ERJ2RKF7322	73.2k	
	R807	ERJ2GEJ512	5.1k	
	R808	ERJ2RKF1201	1.2k	
	R809	D0GA103JA021	10k	
	R810	D0YBR0000020	0	
	R811	ERJ2RKF1272	12.7k	
	R812	D0YBR0000020	0	
	R813	D0YBR0000020	0	
	R814	D0GA472JA021	4.7k	
	R815	D0GA103JA021	10k	
	R816	D0GA102JA021	1k	
	R817	D0GA103JA021	10k	
	R818	D0GA104JA021	100k	
	R819	D0GA102JA021	1k	
	R820	D0GA102JA021	1k	
	R821	D0GA273JA015	27k	
	R822	D0GA473JA021	47k	
	R823	D0YBR0000020	0	
	R825	D0GA273JA015	27k	
	R826	D0GA473JA021	47k	
	R828	ERJ2GEJ564	560k	
	R829	D0GA473JA021	47k	
	R830	D0GA474JA021	470k	
	R831	D0GA474JA021	470k	
	R832	D0GA474JA021	470k	
	R833	D0GA104JA021	100k	
	R834	D0GA104JA021	100k	
	R835	D0GA103JA021	10k	
	R836	D0GA392JA015	3.9k	
	R837	D0GA472JA021	4.7k	
	R838	ERJ2GEJ471	470	S
	R839	D0GA104JA021	100k	
	R840	ERJ2RKF6341X	6.34k	
	R841	ERJ3GEYJ4R7	4.7	S
	R843	ERJ2RKF2200	220	

18.2.6. Main Board (For DP-MB310EU)

Safety	Ref. No.	Part No.	Part Name & Description	Remarks
	R844	ERJ2RKF2200	220	
	R845	ERJ3GEYJ510	51	
	R846	ERJ2GEJ471	470	S
	R847	ERJ2GEJ471	470	S
	R851	D0GA103JA021	10k	
	R853	D0GA330JA015	33	
	R854	D0GA330JA015	33	
	L363	D0GA151JA021	150	
	L369	D0GA221JA021	220	
	L370	D0GA221JA021	220	
	L371	D0GA221JA021	220	
			(COMPONENTS PARTS)	
	RA305	EXB28V220JX	RESISTOR ARRAY	
	RA316	EXB28V470JX	RESISTOR ARRAY	
	RA321	EXB28V220JX	RESISTOR ARRAY	
	RA322	EXB28V220JX	RESISTOR ARRAY	
	RA323	EXB28V220JX	RESISTOR ARRAY	
	RA324	EXB28V220JX	RESISTOR ARRAY	
	RA400	EXB28V220JX	RESISTOR ARRAY	
	RA401	EXB28V220JX	RESISTOR ARRAY	
	RA402	EXB28V220JX	RESISTOR ARRAY	
	RA403	EXB28V220JX	RESISTOR ARRAY	
	RA404	EXB28V470JX	RESISTOR ARRAY	
	RA405	EXB28V470JX	RESISTOR ARRAY	
	RA406	EXB28V470JX	RESISTOR ARRAY	
	RA407	EXB28V220JX	RESISTOR ARRAY	
	RA408	EXB28V220JX	RESISTOR ARRAY	
	RA409	EXB28V220JX	RESISTOR ARRAY	
	RA410	EXB28V220JX	RESISTOR ARRAY	
	RA411	EXB28V470JX	RESISTOR ARRAY	
	RA412	EXB28V470JX	RESISTOR ARRAY	
	RA413	EXB28V470JX	RESISTOR ARRAY	
	RA414	EXB28V330	RESISTOR ARRAY	
	RA415	EXB28V330	RESISTOR ARRAY	
	RA416	EXB28V330	RESISTOR ARRAY	
	RA417	EXB28V330	RESISTOR ARRAY	
	RA418	EXB28V330	RESISTOR ARRAY	
	RA419	EXB28V330	RESISTOR ARRAY	
	RA420	EXB28V330	RESISTOR ARRAY	
	RA421	EXB28V330	RESISTOR ARRAY	
	RA422	EXB28V330	RESISTOR ARRAY	
	RA423	EXB28V330	RESISTOR ARRAY	
	RA424	EXB28V330	RESISTOR ARRAY	
	RA425	EXB28V103JX	RESISTOR ARRAY	
	RA426	EXB28V103JX	RESISTOR ARRAY	
	RA427	EXB28V103JX	RESISTOR ARRAY	
	RA428	EXB28V103JX	RESISTOR ARRAY	
	RA500	EXB28V470JX	RESISTOR ARRAY	
	RA501	EXB28V470JX	RESISTOR ARRAY	
	RA502	EXB28V470JX	RESISTOR ARRAY	
			(RELAY)	
△	RLY100	K6B1CY00005	RELAY	
			(VARISTORS)	
△	SA100	PFRZRA102P6T	VARISTOR (SURGE ABSORBER)	S
△	SA101	PFRZRA102P6T	VARISTOR (SURGE ABSORBER)	S
	SA102	J0LY00000157	VARISTOR (SURGE ABSORBER)	
			(FUSES)	
	F100	K5G102A00041	FUSE	S
△	F600	K5H202Y00003	FUSE	
			(CRYSTAL OSCILLATOR)	
	X300	H0J240500074	CRYSTAL OSCILLATOR	
	X301	H0J245500124	CRYSTAL OSCILLATOR	
	X303	H0A327200186	CRYSTAL OSCILLATOR	
	X500	H0J300500039	CRYSTAL OSCILLATOR	
	X750	H0J250500097	CRYSTAL OSCILLATOR	

Safety	Ref. No.	Part No.	Part Name & Description	Remarks
	PCB1	PNWP1MB310EU	MAIN BOARD ASS'Y (RTL)	
			(ICs)	
	IC100	C1CB00002689	IC	
	IC101	C1CB00002690	IC	
	IC201	C1CB00001769	IC	
	IC203	C1AB00002556	IC	
	IC300	C1ZBZ0004649	IC	
	IC301	C0EBY0000665	IC	
	IC302	C0ZBZ0001747	IC	
	IC303	C0DBGYY03947	IC	
	IC304	C0DBZYY00592	IC	
	IC400	C3ABRY000078	IC	
	IC401	C3ABRY000078	IC	
	IC402	PNWI310EU	IC (ROM)	
	IC403	C0JBAZ001466	IC	
	IC404	C0JBAZ001466	IC	
	IC405	C0JBAZ001539	IC	
	IC406	C0JBAZ001539	IC	
	IC407	C0JBAA000362	IC	
	IC500	C1ZBZ0003879	IC	
	IC502	AN44071A	IC	
	IC503	C0FBAY000092	IC	
	IC504	C0BBBA000024	IC	
	IC750	C1CB00003704	IC	
	IC800	C0DBAYY01433	IC	
	IC801	C0DBAYY01433	IC	
	IC802	C0DBAYY00932	IC	
	IC803	C0DBEYY00102	IC	
			(TRANSISTORS)	
	Q100	DSC710100L	TRANSISTOR (SI)	
	Q101	DSC710100L	TRANSISTOR (SI)	
	Q102	B1ABDP000005	TRANSISTOR (SI)	
	Q103	B1ABDP000005	TRANSISTOR (SI)	
	Q104	B1ADGP000008	TRANSISTOR (SI)	
	Q105	DRC9123J0L	TRANSISTOR (SI)	
	Q200	B1GBCFGN0005	TRANSISTOR (SI)	
	Q500	DSC9001R0L	TRANSISTOR (SI)	
	Q501	B1GBCFGN0005	TRANSISTOR (SI)	
	Q502	B1GBCFGN0005	TRANSISTOR (SI)	
	Q503	B1GBCFGN0005	TRANSISTOR (SI)	
	Q504	B1GBCFGN0005	TRANSISTOR (SI)	
	Q505	B1GBCFGN0005	TRANSISTOR (SI)	
	Q506	B1GBCFGN0005	TRANSISTOR (SI)	
	Q507	B1ABGE000014	TRANSISTOR (SI)	
	Q508	B1ADKE000002	TRANSISTOR (SI)	
	Q509	B1ADKE000002	TRANSISTOR (SI)	
	Q510	B1ABGE000014	TRANSISTOR (SI)	
	Q511	B1ABGE000014	TRANSISTOR (SI)	
	Q512	B1GBCFGN0005	TRANSISTOR (SI)	
	Q513	B1GBCFGN0005	TRANSISTOR (SI)	
	Q514	B1ABGE000011	TRANSISTOR (SI)	
	Q516	B1ABGE000011	TRANSISTOR (SI)	
	Q517	B1ABGE000011	TRANSISTOR (SI)	
	Q518	B1ADGE000012	TRANSISTOR (SI)	
	Q520	B1GBCFGN0005	TRANSISTOR (SI)	
	Q525	B1GBCFGN0005	TRANSISTOR (SI)	
	Q526	B1GBCFGN0005	TRANSISTOR (SI)	
	Q527	DRC9123J0L	TRANSISTOR (SI)	
	Q528	DSC9001R0L	TRANSISTOR (SI)	
	Q529	B1GBCFGN0005	TRANSISTOR (SI)	
	Q530	DSC9001R0L	TRANSISTOR (SI)	
	Q600	B1ADGE000012	TRANSISTOR (SI)	
	Q601	B1ADGE000012	TRANSISTOR (SI)	
	Q602	B1GBCFGN0005	TRANSISTOR (SI)	
	Q603	B1ADGE000012	TRANSISTOR (SI)	
	Q604	B1ADCF000020	TRANSISTOR (SI)	
	Q605	DRA9143Z0L	TRANSISTOR (SI)	
	Q607	DSC9001R0L	TRANSISTOR (SI)	
	Q608	B1ADGE000012	TRANSISTOR (SI)	
	Q609	B1ADGE000012	TRANSISTOR (SI)	

Safety	Ref. No.	Part No.	Part Name & Description	Remarks
	Q610	B1GBCFGN0005	TRANSISTOR (SI)	
	Q611	B1GBCFGN0005	TRANSISTOR (SI)	
	Q612	B1GBCFGN0005	TRANSISTOR (SI)	
	Q613	B1ADCF000020	TRANSISTOR (SI)	
	Q614	DRA9143Z0L	TRANSISTOR (SI)	
	Q650	B1ADCF000020	TRANSISTOR (SI)	
	Q651	DSC9001R0L	TRANSISTOR (SI)	
	Q700	B1ABGE000014	TRANSISTOR (SI)	
	Q701	B1ABGE000014	TRANSISTOR (SI)	
	Q702	B1GBCFGN0005	TRANSISTOR (SI)	
	Q703	DRA9143Z0L	TRANSISTOR (SI)	
	Q800	B1CHND000004	TRANSISTOR (SI)	
	Q801	B1GBCFGN0005	TRANSISTOR (SI)	
	Q802	B1CHND000004	TRANSISTOR (SI)	
	Q803	DRA9143Z0L	TRANSISTOR (SI)	
	Q804	DSC9001R0L	TRANSISTOR (SI)	
	Q805	DSC9001R0L	TRANSISTOR (SI)	
	Q806	B1GBCFGN0005	TRANSISTOR (SI)	
	Q807	B1CHQD000018	TRANSISTOR (SI)	
	Q808	B1CHQD000018	TRANSISTOR (SI)	
	Q809	B1ADCF000020	TRANSISTOR (SI)	
	Q810	DSC9001R0L	TRANSISTOR (SI)	
	Q812	B1GBCFGN0005	TRANSISTOR (SI)	
	Q813	B1CHQD000018	TRANSISTOR (SI)	
	Q814	B1ADCF000020	TRANSISTOR (SI)	
	Q815	B1GBCFGN0005	TRANSISTOR (SI)	
			(DIODES)	
	D100	DZ2W30000L	DIODE (SI)	
	D101	BOEDER000009	DIODE (SI)	
	D102	DA2J10100L	DIODE (SI)	
	D103	DZ2J056M0L	DIODE (SI)	
	D104	DZ2J056M0L	DIODE (SI)	
	D301	DD2S06200L	DIODE (SI)	
	D302	DD2S06200L	DIODE (SI)	
	D306	BOZBZ0000146	DIODE (SI)	
	D600	DA2J10100L	DIODE (SI)	
	D601	DA2J10100L	DIODE (SI)	
	D801	DZ2W05600L	DIODE (SI)	S
	D803	DZ2W05600L	DIODE (SI)	S
	D804	BOJCN0000031	DIODE (SI)	
	D805	BOBC6R5A0541	DIODE (SI)	
	D806	PJVDJADAN202	DIODE (SI)	S
	D807	DA2J10100L	DIODE (SI)	
	DA300	BOADEJ000025	DIODE (SI)	
	LED750	B3ABB0000331	DIODE (SI)	
			(BATTERY)	
	BAT300	BR2032/1HF1	BATTERY	S
			(CAPACITORS)	
	C100	ECUE1C103KBQ	0.01	S
	C101	ECUE1A104KBQ	0.1	S
	C102	ECUE1A104KBQ	0.1	S
⚠	C103	F1BAF330A048	33p	
⚠	C104	F1BAF330A048	33p	
	C105	EEE1HA010SR	1	
	C106	ECUE1A104KBQ	0.1	S
	C107	ECUE1A104KBQ	0.1	S
	C108	F1J2E121A023	0.00012	
	C109	F1J2E121A023	0.00012	
	C110	F1G1H272A571	0.0027	
	C111	ECUE1C103KBQ	0.01	S
	C112	ECUE1C103KBQ	0.01	S
	C113	F1J2E1030004	0.01	
	C114	F1G1H101A557	0.0001	
	C115	F0C2E1050004	1	
⚠	C116	F1BAF471A049	470p	
⚠	C117	F1BAF471A049	470p	
⚠	C119	F1BAF330A048	33p	
	C203	ECUE1C103KBQ	0.01	S
	C204	ECUE1A104KBQ	0.1	S
	C206	ECUE1C223KBQ	0.022	S
	C207	ECUE1A104KBQ	0.1	S
	C209	ECUE1A104KBQ	0.1	S
	C211	ECUE1A104KBQ	0.1	S

Safety	Ref. No.	Part No.	Part Name & Description	Remarks
	C212	ECUE1C223KBQ	0.022	S
	C226	F1G0J105A007	10	
	C227	F1G0J105A007	10	
	C229	ECJOEB1H392K	0.0039	
	C232	F1J0J2260004	220	
	C300	ECUE1A104KBQ	0.1	S
	C301	ECUE1C103KBQ	0.01	S
	C302	ECUE1A104KBQ	0.1	S
	C303	ECUE1A104KBQ	0.1	S
	C304	ECUE1A104KBQ	0.1	S
	C305	ECUE1A104KBQ	0.1	S
	C306	ECUE1A104KBQ	0.1	S
	C307	ECUE1A104KBQ	0.1	S
	C308	F1G0J105A007	10	
	C309	F1G1A273A032	0.27	
	C310	F1G1H100A565	1p	
	C311	F1G1H180A565	18p	
	C312	ECUE1A104KBQ	0.1	S
	C313	F1G1H180A565	18p	
	C314	F1G1H180A565	18p	
	C319	F1G0J105A007	10	
	C322	ECUE1A104KBQ	0.1	S
	C325	F1G0J105A007	10	
	C326	ECUE1C103KBQ	0.01	S
	C327	ECUE1A104KBQ	0.1	S
	C328	F1G0J224A044	0.22	
	C329	F1G0J224A044	0.22	
	C330	F1H0J105A037	1	
	C331	F1H0J105A037	1	
	C340	ECUE1A104KBQ	0.1	S
	C341	ECUE1A104KBQ	0.1	S
	C342	ECUE1A104KBQ	0.1	S
	C343	ECUE1A104KBQ	0.1	S
	C344	ECUE1C103KBQ	0.01	S
	C351	F1G1H101A557	0.0001	
	C356	ECUE1A104KBQ	0.1	S
	C357	ECUE1A104KBQ	0.1	S
	C358	ECUE1A104KBQ	0.1	S
	C359	ECUE1A104KBQ	0.1	S
	C360	ECUE1A104KBQ	0.1	S
	C361	ECUE1A104KBQ	0.1	S
	C362	ECUE1A104KBQ	0.1	S
	C363	ECUE1A104KBQ	0.1	S
	C364	ECUE1A104KBQ	0.1	S
	C365	ECUE1H102KBQ	0.001	S
	C366	ECUE1A104KBQ	0.1	S
	C367	F1G0J105A007	10	
	C368	F1G0J105A007	10	
	C369	F1G0J105A007	10	
	C370	F1H1A105A025	1	
	C371	F1H0J1060006	10	
	C400	F1H0J105A037	1	
	C401	F1H0J105A037	1	
	C402	F1H0J105A037	1	
	C403	F1H0J105A037	1	
	C404	F1H0J105A037	1	
	C405	F1H0J105A037	1	
	C406	F1H0J105A037	1	
	C407	F1H0J105A037	1	
	C408	ECUE1A104KBQ	0.1	S
	C409	ECUE1A104KBQ	0.1	S
	C410	ECUE1A104KBQ	0.1	S
	C411	ECUE1A104KBQ	0.1	S
	C412	ECUE1A104KBQ	0.1	S
	C413	ECUE1A104KBQ	0.1	S
	C414	ECUE1A104KBQ	0.1	S
	C440	ECUE1A104KBQ	0.1	S
	C441	ECUE1A104KBQ	0.1	S
	C442	ECUE1A104KBQ	0.1	S
	C443	ECUE1A104KBQ	0.1	S
	C444	ECUE1A104KBQ	0.1	S
	C445	ECUE1A104KBQ	0.1	S
	C446	ECUE1A104KBQ	0.1	S

Safety	Ref. No.	Part No.	Part Name & Description	Remarks
	C447	ECUE1A104KBQ	0.1	S
	C448	ECUE1A104KBQ	0.1	S
	C449	ECUE1A104KBQ	0.1	S
	C450	ECUE1A104KBQ	0.1	S
	C451	ECUE1A104KBQ	0.1	S
	C452	ECUE1A104KBQ	0.1	S
	C453	ECUE1A104KBQ	0.1	S
	C454	ECUE1A104KBQ	0.1	S
	C455	ECUE1A104KBQ	0.1	S
	C456	ECUE1A104KBQ	0.1	S
	C457	ECUE1A104KBQ	0.1	S
	C458	ECUE1A104KBQ	0.1	S
	C459	ECUE1A104KBQ	0.1	S
	C460	ECUE1A104KBQ	0.1	S
	C461	ECUE1A104KBQ	0.1	S
	C462	ECUE1A104KBQ	0.1	S
	C463	ECUE1A104KBQ	0.1	S
	C464	ECUE1A104KBQ	0.1	S
	C465	ECUE1A104KBQ	0.1	S
	C466	ECUE1A104KBQ	0.1	S
	C467	ECUE1A104KBQ	0.1	S
	C468	ECUE1A104KBQ	0.1	S
	C469	ECUE1A104KBQ	0.1	S
	C470	ECUE1A104KBQ	0.1	S
	C471	ECUE1A104KBQ	0.1	S
	C472	ECUE1A104KBQ	0.1	S
	C473	ECUE1A104KBQ	0.1	S
	C474	ECUE1A104KBQ	0.1	S
	C475	ECUE1A104KBQ	0.1	S
	C476	ECUE1A104KBQ	0.1	S
	C477	ECUE1A104KBQ	0.1	S
	C478	ECUE1A104KBQ	0.1	S
	C479	ECUE1A104KBQ	0.1	S
	C485	F1H1H104A220	0.1	
	C486	F1H1H104A220	0.1	
	C487	F1H1H104A220	0.1	
	C488	F1H1H104A220	0.1	
	C489	F1H1H104A220	0.1	
	C490	F1H1H104A220	0.1	
	C491	F1H1H104A220	0.1	
	C492	F1H1H104A220	0.1	
	C493	F1H1H104A220	0.1	
	C494	F1H1H104A220	0.1	
	C495	F1H1H104A220	0.1	
	C496	F1H1H104A220	0.1	
	C497	F1H1H104A220	0.1	
	C498	F1H1H104A220	0.1	
	C499	F1H1H104A220	0.1	
	C500	ECUE1H8R0DCQ	8	
	C501	F1G1H220A565	22p	
	C503	ECUE1A104KBQ	0.1	S
	C504	ECUE1C103KBQ	0.01	S
	C505	ECUE1H181JCQ	180p	S
	C506	ECUE1H181JCQ	180p	S
	C507	ECUE1H102KBQ	0.001	S
	C508	ECJ0EB1A473K	0.047	S
	C509	ECUE1H181JCQ	180p	S
	C510	ECUE1A104KBQ	0.1	S
	C511	ECUE1A104KBQ	0.1	S
	C512	ECUE1A104KBQ	0.1	S
	C513	ECUE1A104KBQ	0.1	S
	C514	ECUE1A104KBQ	0.1	S
	C515	ECUE1H181JCQ	180p	S
	C516	ECUE1H102KBQ	0.001	S
	C517	ECUE1A104KBQ	0.1	S
	C518	F1H1H104A220	0.1	S
	C519	ECUE1A104KBQ	0.1	S
	C520	ECUE1H181JCQ	180p	S
	C522	ECUE1A104KBQ	0.1	S
	C523	ECUE1H181JCQ	180p	S
	C524	F1G1H220A565	22p	
	C525	ECUE1H102KBQ	0.001	S
	C526	ECUE1H102KBQ	0.001	S

Safety	Ref. No.	Part No.	Part Name & Description	Remarks
	C527	ECUE1H102KBQ	0.001	S
	C528	ECUE1H102KBQ	0.001	S
	C529	ECUE1H102KBQ	0.001	S
	C530	ECUE1A104KBQ	0.1	S
	C531	F1J1A106A024	10	
	C532	ECUE1H181JCQ	180p	S
	C533	ECUE1A104KBQ	0.1	S
	C534	ECUE1A104KBQ	0.1	S
	C535	ECUE1H102KBQ	0.001	S
	C536	ECUE1A104KBQ	0.1	S
	C537	ECUE1A104KBQ	0.1	S
	C538	F1G0J105A007	10	
	C539	ECUE1H102KBQ	0.001	S
	C540	ECUE1A104KBQ	0.1	S
	C541	ECUE1H102KBQ	0.001	S
	C542	ECUE1H181JCQ	180p	S
	C543	ECUE1A104KBQ	0.1	S
	C544	ECUE1C103KBQ	0.01	S
	C545	F1G0J105A007	10	
	C546	ECUE1C103KBQ	0.01	S
	C548	ECUE1H102KBQ	0.001	S
	C549	EEE0JA101WR	100	
	C551	ECUE1H102KBQ	0.001	S
	C552	F1H1H104A220	0.1	
	C553	ECUE1H102KBQ	0.001	S
	C554	ECUE1H102KBQ	0.001	S
	C555	ECUE1A104KBQ	0.1	S
	C556	ECUV0J474KBV	0.47	
	C557	ECUE1H181JCQ	180p	S
	C558	ECUE1H102KBQ	0.001	S
	C559	ECUE1H102KBQ	0.001	S
	C561	ECUE1H102KBQ	0.001	S
	C562	ECUE1H102KBQ	0.001	S
	C563	ECUE1H102KBQ	0.001	S
	C565	ECJ0EB1A473K	0.047	S
	C569	ECJ0EB1A473K	0.047	S
	C571	ECUE1A104KBQ	0.1	S
	C572	F1G0J105A007	10	
	C576	ECUE1A104KBQ	0.1	S
	C577	ECUE1H102KBQ	0.001	S
	C600	ECUE1H102KBQ	0.001	S
	C601	ECUE1H102KBQ	0.001	S
	C613	F2G1V1010021	100	
	C615	F1G1H101A557	0.0001	
	C618	F1G0J105A007	10	
	C619	ECUE1H102KBQ	0.001	S
	C620	ECUE1H102KBQ	0.001	S
	C621	ECUE1H102KBQ	0.001	S
	C622	ECUE1H102KBQ	0.001	S
	C623	ECUE1H102KBQ	0.001	S
	C624	ECUE1H102KBQ	0.001	S
	C625	ECUE1H102KBQ	0.001	S
	C626	F1H1H104A220	0.1	
	C627	ECUE1H102KBQ	0.001	S
	C628	ECUE1H102KBQ	0.001	S
	C650	ECUE1C103KBQ	0.01	S
	C652	F1G0J105A007	10	
	C654	ECUE1A104KBQ	0.1	S
	C655	ECUE1H103ZFQ	0.01	S
	C656	ECUE1H103ZFQ	0.01	S
	C657	ECUE1A104KBQ	0.1	S
	C700	ECUE1C103KBQ	0.01	S
	C701	ECUE1H102KBQ	0.001	S
	C702	ECUE1H102KBQ	0.001	S
	C703	ECUE1H102KBQ	0.001	S
	C709	ECUE1H222KBQ	0.0022	S
	C710	ECUE1H222KBQ	0.0022	S
	C711	ECUE1H222KBQ	0.0022	S
	C712	ECUE1H222KBQ	0.0022	S
	C751	ECUE1A104KBQ	0.1	S
	C752	F1J1C106A191	10	
	C753	ECUE1A104KBQ	0.1	S
	C754	ECUE1C103KBQ	0.01	S

Safety	Ref. No.	Part No.	Part Name & Description	Remarks
	C755	ECUE1C103KBQ	0.01	S
	C756	ECUE1H070DCQ	7p	S
	C757	ECJ0EC1H120J	12p	S
	C758	ECUE1A104KBQ	0.1	S
	C759	ECUE1A104KBQ	0.1	S
	C760	ECUE1A104KBQ	0.1	S
	C761	ECUE1A104KBQ	0.1	S
	C762	FLJ1C106A191	10	
	C763	ECUE1A104KBQ	0.1	S
	C764	ECUE1A104KBQ	0.1	S
	C765	ECUE1A104KBQ	0.1	S
	C766	ECUE1A104KBQ	0.1	S
	C767	ECUE1A104KBQ	0.1	S
	C768	FLG1H100A565	1p	
	C800	FLG0J105A007	10	
	C801	FLK1E1060004	10	
	C802	FLH1H104A220	0.1	
	C803	ECUE1A104KBQ	0.1	S
	C804	FLG0J105A007	10	
	C805	FLG1E472A086	0.0047	
	C806	FLG1H100A565	1p	
	C807	FLK0J476A009	47	
	C808	FLK1E1060004	10	
	C809	FLH1H104A220	0.1	
	C810	ECUE1A104KBQ	0.1	S
	C811	FLH1H104A220	0.1	
	C813	FLG0J105A007	10	
	C814	FLG1E472A086	0.0047	
	C815	F2G1V4700028	47	
	C816	FLK0J476A009	47	
	C817	FLH1C105A118	1	
	C818	FLH1C105A118	1	
	C819	FLK1E1060004	10	
	C820	FLH1H104A220	0.1	
	C822	FLJ1C475A059	4.7	
	C823	ECUE1H102KBQ	0.001	S
	C824	ECUE1H102KBQ	0.001	S
	C826	ECUE1H102KBQ	0.001	S
	C829	FLJ1A106A024	10	
	C830	FLG0J105A007	10	
	C831	FLJ1A106A024	10	
	C832	FLJ1C475A059	4.7	
	C833	FLH1H104A220	0.1	
	C834	F2G1V4700028	47	
	C835	FLJ1A106A024	10	
	C836	FLJ1A106A024	10	
	C837	FLH1H104A748	0.1	
	C863	ECUE1H471KBQ	470p	S
			(CONNECTORS AND JACKS)	
	CN100	K2LB106B0053	JACK/SOCKET	
	CN101	K2LB106B0053	JACK/SOCKET	
	CN201	K1KA02A00587	CONNECTOR, 2PIN	
	CN300	K1FY104B0015	CONNECTOR, 4PIN	
	CN301	K1KA05AA0193	CONNECTOR, 5PIN	
	CN500	K1KA09A00236	CONNECTOR, 9PIN	
	CN501	K1KA05A00364	CONNECTOR, 5PIN	
	CN503	K1KA04A00527	CONNECTOR, 4PIN	
	CN504	K1KA10A00412	CONNECTOR, 10PIN	
	CN505	K1KA07A00257	CONNECTOR, 7PIN	
	CN506	K1KA02A00587	CONNECTOR, 2PIN	
	CN507	K1KA06A00428	CONNECTOR, 6PIN	
	CN508	K1KA02A00745	CONNECTOR, 2PIN	
	CN509	K1KA06A00499	CONNECTOR, 4PIN	
	CN510	K1KA04A00527	CONNECTOR, 4PIN	
	CN511	K1KA06A00428	CONNECTOR, 6PIN	
	CN513	K1MY12AA0238	CONNECTOR, 12PIN	
	CN514	K1KA11A00158	CONNECTOR, 11PIN	
	CN515	K1KA08A00440	CONNECTOR, 8PIN	
	CN516	K1KA04AA0193	CONNECTOR, 4PIN	
	CN517	K1KA08A00440	CONNECTOR, 8PIN	
	CN518	K1KA08AA0193	CONNECTOR, 8PIN	
	CN519	K1KA03A00612	CONNECTOR, 3PIN	
	CN700	K1KA12A00315	CONNECTOR, 12PIN	

Safety	Ref. No.	Part No.	Part Name & Description	Remarks
	CN750	K2LC108B0112	JACK/SOCKET	
	CN800	K1KA03A00495	CONNECTOR, 3PIN	
			(COILS)	
	L104	PQLQR2BT	COIL	S
	L105	PQLQR2BT	COIL	S
	L106	PQLQR2BT	COIL	S
	L107	PQLQR2BT	COIL	S
	L108	PQLQR2BT	COIL	S
	L109	PQLQR2BT	COIL	S
	L110	G0B862C00003	COIL	
	L300	G1BYYC00026	COIL	
	L301	G1BYYC00026	COIL	
	L305	G1BYYC00026	COIL	
	L306	G1BYYC00026	COIL	
	L372	J0JCC0000278	COIL	
	L508	PFVF2P221SG	COIL	S
	L511	PQLQR2KB113T	COIL	S
	L752	G1BYYYY00010	COIL	
	L753	G1BYYYY00010	COIL	
	L800	G1C4R7MA0445	COIL	
	L801	G1C2R2MA0395	COIL	
	L802	G1C4R7MA0445	COIL	
			(IC FILTERS)	
	L100	J0JCC0000002	IC FILTER	
	L101	J0JCC0000002	IC FILTER	
	L102	J0JBC0000040	IC FILTER	
	L103	J0JBC0000040	IC FILTER	
	L210	J0JCC0000288	IC FILTER	
	L211	J0JCC0000288	IC FILTER	
	L214	J0JCC0000276	IC FILTER	
	L302	J0JCC0000308	IC FILTER	
	L303	J0JCC0000308	IC FILTER	
	L304	J0JAC0000059	IC FILTER	
	L307	J0JYC0000070	IC FILTER	
	L344	J0JCC0000286	IC FILTER	
	L345	J0JCC0000286	IC FILTER	
	L346	J0JCC0000286	IC FILTER	
	L347	J0JCC0000286	IC FILTER	
	L348	J0JCC0000277	IC FILTER	
	L349	J0JCC0000277	IC FILTER	
	L350	J0JCC0000277	IC FILTER	
	L351	J0JCC0000277	IC FILTER	
	L352	J0JCC0000277	IC FILTER	
	L353	J0JCC0000277	IC FILTER	
	L354	J0JCC0000277	IC FILTER	
	L355	J0JCC0000277	IC FILTER	
	L356	J0JCC0000413	IC FILTER	
	L357	J0MAB0000144	IC FILTER	
	L358	J0JCC0000277	IC FILTER	
	L359	J0JCC0000277	IC FILTER	
	L360	J0JCC0000276	IC FILTER	
	L361	J0JCC0000275	IC FILTER	
	L362	J0JCC0000276	IC FILTER	
	L364	J0JCC0000274	IC FILTER	
	L365	J0JCC0000286	IC FILTER	
	L504	J0HAAB000002	IC FILTER	
	L506	J0JCC0000276	IC FILTER	
	L507	J0JCC0000276	IC FILTER	
	L509	J0JAC0000059	IC FILTER	
	L510	J0JCC0000276	IC FILTER	
	L750	J0JCC0000276	IC FILTER	
	L751	J0JCC0000251	IC FILTER	
	R559	J0JCC0000276	IC FILTER	
	R750	J0JCC0000308	IC FILTER	
			(RESISTORS)	
	R100	D0GA473JA021	47k	
	R102	D0GB560JA057	56	
	R103	D0GB560JA057	56	
	R104	ERJ2RKF1004	1m	
	R105	ERJ12SF1071	1m	
	R106	ERJ6GEYJ515	5.1m	
	R107	ERJ6GEYJ515	5.1m	
	R108	ERJ12SF3651	3.65k	

Safety	Ref. No.	Part No.	Part Name & Description	Remarks
	R109	D0GF156JA051	15m	
	R110	D0GF156JA051	15m	
	R111	D0GA151JA021	150	
	R112	ERJ8ENF5360	536	
	R113	ERJ12SF73R2	73.2	
	R114	ERJ12SF2491	2.49k	
	R115	D0GA104JA021	100k	
	R116	D0GA104JA021	100k	
	R117	ERDS1TJ223	22k	S
	R119	ERG1SJ120E	12	
	R121	D0GA103JA021	10k	
	R122	PQ4R18XJ100	10	S
	R200	D0YBR0000020	0	
	R204	D0YBR0000020	0	
	R205	D0YBR0000020	0	
	R206	D0GA473JA021	47k	
	R207	D0GA332JA015	3.3k	
	R212	D0GA472JA021	4.7k	
	R213	D0GA103JA021	10k	
	R215	D0GA105JA021	1m	
	R216	D0GA472JA021	4.7k	
	R227	D0GA102JA021	1k	
	R229	D0GA273JA015	27k	
	R233	PQ4R18XJ100	10	S
	R234	ERJ2GEYJ154	150k	S
	R235	D0GA124JA015	120k	
	R302	D0GA103JA021	10k	
	R303	D0GA103JA021	10k	
	R304	ERJ2GEJ101	100	S
	R305	D0GA103JA021	10k	
	R306	D0GA102JA021	1k	
	R307	D0GA103JA021	10k	
	R309	ERJ2RKF3301	3.3k	
	R310	ERJ2RKF6801	6.8k	
	R311	ERJ2GEOR00	0	S
	R312	ERJ2GEOR00	0	S
	R313	ERJ2GEOR00	0	S
	R314	ERJ2GEOR00	0	S
	R315	D0GA103JA021	10k	
	R316	D0GA103JA021	10k	
	R317	D0GA470JA021	47	
	R318	D0GA470JA021	47	
	R319	D0GA104JA021	100k	
	R320	ERJ2RKF1212	12.1k	
	R321	D0GA103JA021	10k	
	R322	D0GA103JA021	10k	
	R323	D0GA103JA021	10k	
	R324	ERJ2RKF1212	12.1k	
	R325	D0GA103JA021	10k	
	R327	ERJ2GEOR00	0	S
	R329	ERJ2GEOR00	0	S
	R331	ERJ2GEOR00	0	S
	R332	ERJ2GEOR00	0	S
	R335	ERJ2GEOR00	0	S
	R338	D0GA103JA021	10k	
	R339	ERJ2GEJ823	82k	S
	R345	D0GA103JA021	10k	
	R346	D0GA152JA021	1.5k	
	R347	D0YBR0000020	0	
	R348	D0YBR0000020	0	
	R352	D0GA103JA021	10k	
	R354	D0GA103JA021	10k	
	R355	D0GA103JA021	10k	
	R356	ERJ3GEYJ6R8	6.8	
	R357	ERJ3GEYJ6R8	6.8	
	R359	D0GA104JA021	100k	
	R361	D0GA103JA021	10k	
	R362	D0GA103JA021	10k	
	R364	D0GA103JA021	10k	
	R366	D0GA470JA021	47	
	R367	D0GA151JA021	150	
	R368	D0GA151JA021	150	
	R369	D0GA151JA021	150	

Safety	Ref. No.	Part No.	Part Name & Description	Remarks
	R370	D0GA104JA021	100k	
	R371	D0GA103JA021	10k	
	R372	D0GA103JA021	10k	
	R373	D0GA103JA021	10k	
	R377	D0GA103JA021	10k	
	R379	D0GA470JA021	47	
	R382	ERJ2GEOR00	0	S
	R383	ERJ2GEOR00	0	S
	R384	ERJ2GEJ101	100	S
	R385	D0GA105JA021	1m	
	R386	D0GA151JA021	150	
	R387	D0GA470JA021	47	
	R388	ERJ2GEYJ683	68k	S
	R389	D0GA102JA021	1k	
	R391	D0GA103JA021	10k	
	R395	D0GA470JA021	47	
	R399	D0GA103JA021	10k	
	R400	D0GA470JA021	47	
	R401	D0GA680JA015	68	
	R402	D0GA470JA021	47	
	R403	D0GA470JA021	47	
	R404	D0GA470JA021	47	
	R405	D0GA470JA021	47	
	R406	D0GA470JA021	47	
	R407	D0GA470JA021	47	
	R408	D0GA470JA021	47	
	R409	D0GA560JA015	56	
	R410	D0GA680JA015	68	
	R411	D0GA680JA015	68	
	R412	D0GA470JA021	47	
	R413	D0GA470JA021	47	
	R414	D0GA470JA021	47	
	R415	D0GA470JA021	47	
	R416	D0GA470JA021	47	
	R417	D0GA470JA021	47	
	R418	D0GA470JA021	47	
	R419	D0GA560JA015	56	
	R420	D0GA680JA015	68	
	R421	D0GA470JA021	47	
	R422	D0GA330JA015	33	
	R423	D0GA103JA021	10k	
	R424	D0GA103JA021	10k	
	R425	ERJ2GEJ820	82	S
	R450	D0GA103JA021	10k	
	R451	D0GA103JA021	10k	
	R495	D0YBR0000020	0	
	R496	D0YBR0000020	0	
	R497	D0YBR0000020	0	
	R498	D0YBR0000020	0	
	R500	D0GA220JA021	22	
	R501	ERJ2GEJ101	100	S
	R502	ERJ2GEJ101	100	S
	R503	ERJ2RKF1502	15k	
	R504	D0GA473JA021	47k	
	R505	ERJ2RKF3012	30.1k	
	R506	D0GA223JA015	22k	
	R507	D0GA221JA021	220	
	R508	D0GA330JA015	33	
	R509	D0GA102JA021	1k	
	R510	D0GA562JA021	5.6k	
	R511	D0GA105JA021	1m	
	R512	ERJ2GEJ563	56k	S
	R515	D0GA102JA021	1k	
	R516	ERJ2GEJ622X	6.2k	
	R517	D0GA103JA021	10k	
	R518	D0GA472JA021	4.7k	
	R519	D0GA103JA021	10k	
	R520	D0GA103JA021	10k	
	R521	D0GA470JA021	47	
	R522	ERJ3GEYJ6R8	6.8	
	R523	ERJ2GEJ563	56k	S
	R524	ERJ2GEOR00	0	S
	R525	ERJ2GEOR00	0	S

Safety	Ref. No.	Part No.	Part Name & Description	Remarks
	R526	D0GA330JA015	33	
	R527	D0GA562JA021	5.6k	
	R528	D0GA330JA015	33	
	R529	ERJ2GE0R00	0	s
	R530	ERJ2GEJ471	470	s
	R531	D0GA330JA015	33	
	R533	D0GA473JA021	47k	
	R534	D0GA222JA021	2.2k	
	R535	D0GA473JA021	47k	
	R536	D0GA474JA021	470k	
	R537	D0GA473JA021	47k	
	R538	D0GA152JA021	1.5k	
	R539	D0GA182JA015	1.8k	
	R541	ERJ2GEYJ331	330	s
	R542	D0GA681JA021	680	
	R543	ERJ3GEYJ390	39	
	R544	ERJ2GEYJ331	330	s
	R545	D0GA330JA015	33	
	R546	D0GA681JA021	680	
	R547	D0GA330JA015	33	
	R548	D0GA330JA015	33	
	R549	D0GB560JA057	56	
	R550	ERJ2GEYJ331	330	s
	R551	D0GA473JA021	47k	
	R552	D0GA102JA021	1k	
	R553	D0GA181JA021	180	
	R554	D0GA681JA021	680	
	R555	D0GA472JA021	4.7k	
	R556	ERJ3GEYJ680	68	s
	R557	D0GA473JA021	47k	
	R558	D0GA102JA021	1k	
	R560	D0GA181JA021	180	
	R561	D0GA102JA021	1k	
	R562	D0GA102JA021	1k	
	R563	ERJ2GEJ101	100	s
	R564	ERJ2RKF1802	18k	
	R566	ERJ2GEJ563	56k	s
	R567	D0GA103JA021	10k	
	R568	ERJ2RKF3902	39k	
	R569	D0GA473JA021	47k	
	R570	D0GA102JA021	1k	
	R571	ERJ2GEJ563	56k	s
	R574	D0GA103JA021	10k	
	R575	ERJ2GEJ564	560k	
	R576	D0GA104JA021	100k	
	R577	D0GA472JA021	4.7k	
	R578	D0GA473JA021	47k	
	R579	ERJ2GEJ471	470	s
	R580	D0GA102JA021	1k	
	R581	ERJ2RKF2551	2.55k	
	R582	D0GA473JA021	47k	
	R583	D0GA104JA021	100k	
	R584	ERJ2RKF1502	15k	
	R585	D0GA562JA021	5.6k	
	R586	ERJ2GEJ563	56k	s
	R587	D0GA223JA015	22k	
	R588	D0GA223JA015	22k	
	R589	PQ4R10XJ332	3.3k	s
	R590	ERJ2GEJ563	56k	s
	R591	D0GA473JA021	47k	
	R592	D0GA473JA021	47k	
	R593	PQ4R10XJ332	3.3k	s
	R594	D0GA102JA021	1k	
	R595	D0GA562JA021	5.6k	
	R596	D0GA562JA021	5.6k	
	R598	D0GA562JA021	5.6k	
	R599	D0GA562JA021	5.6k	
	R600	ERJ12YJ680	68	
	R601	ERJ12YJ680	68	
	R602	D0GA473JA021	47k	
	R603	D0GA473JA021	47k	
	R604	D0GA472JA021	4.7k	
	R605	D0GB222JA057	2.2k	

Safety	Ref. No.	Part No.	Part Name & Description	Remarks
	R606	D0GA562JA021	5.6k	
	R607	D0GB222JA057	2.2k	
	R608	D0GA473JA021	47k	
	R609	PQ4R18XJ121	120	s
	R611	D0GA183JA015	18k	
	R612	D0GA333JA015	33k	
	R613	ERJ2GEJ564	560k	
	R616	ERJ12YJ390H	39	s
	R619	D0GA103JA021	10k	
	R620	ERJ2GEJ563	56k	s
	R621	D0GA562JA021	5.6k	
	R622	D0GA473JA021	47k	
	R623	ERJ2RKF1503	150k	
	R624	ERJ2RKF2202X	22k	
	R627	PQ4R18XJ472	4.7k	s
	R629	D0GA102JA021	1k	
	R630	ERJ2RKF1503	150k	
	R632	D0GA562JA021	5.6k	
	R633	D0GA223JA015	22k	
	R634	D0GA562JA021	5.6k	
	R635	ERJ2GEJ563	56k	s
	R636	ERJ2GEYJ683	68k	s
	R637	D0GA103JA021	10k	
	R638	D0GA472JA021	4.7k	
	R640	ERJ2GEJ471	470	s
	R641	D0GA562JA021	5.6k	
	R642	ERJ2GEJ563	56k	s
	R643	ERJ2GEJ471	470	s
	R644	D0GA102JA021	1k	
	R645	ERJ2GEJ471	470	s
	R646	ERJ2GEJ563	56k	s
	R647	D0GA562JA021	5.6k	
	R648	ERJ2GEJ471	470	s
	R649	ERJ2GEJ471	470	s
	R650	ERJ2GEJ471	470	s
	R652	D0GA103JA021	10k	
	R655	ERJ2GEJ823	82k	s
	R656	D0GA473JA021	47k	
	R657	ERJ8GEYJ2R7	2.7	
	R658	ERJ8GEYJ2R7	2.7	
	R659	D0GA103JA021	10k	
	R660	D0GA183JA015	18k	
	R661	D0GA472JA021	4.7k	
	R662	D0GA183JA015	18k	
	R663	D0GA472JA021	4.7k	
	R664	D0GA103JA021	10k	
	R665	D0GA473JA021	47k	
	R666	ERJ8RQFR56V	0.56	
	R667	ERJ8RQFR22	0.22	
	R669	ERJ8RQFR22	0.22	
	R670	ERJ8RQFR56V	0.56	
	R671	ERJ2GEYJ154	150k	s
	R672	ERJ2GEJ184	180k	s
	R673	D0GA473JA021	47k	
	R674	ERJ2GEJ101	100	s
	R683	D0GA103JA021	10k	
	R687	ERJ12YJ680	68	
	R688	ERJ12YJ680	68	
	R689	D0GA473JA021	47k	
	R690	D0GA473JA021	47k	
	R691	D0GB222JA057	2.2k	
	R692	D0GB222JA057	2.2k	
	R693	PQ4R18XJ121	120	s
	R694	D0GA472JA021	4.7k	
	R695	D0GA473JA021	47k	
	R696	D0GA183JA015	18k	
	R697	D0GA333JA015	33k	
	R701	ERJ2GEJ563	56k	s
	R702	ERJ2GEJ563	56k	s
	R703	ERJ2GEJ563	56k	s
	R704	D0GA562JA021	5.6k	
	R705	D0GA562JA021	5.6k	
	R706	D0GA562JA021	5.6k	

Safety	Ref. No.	Part No.	Part Name & Description	Remarks
	R707	D0GA102JA021	1k	
	R708	D0GA473JA021	47k	
	R711	D0GA102JA021	1k	
	R712	D0GA473JA021	47k	
	R751	ERJ2RKF2491X	2.49k	
	R752	D0GA472JA021	4.7k	
	R755	D0GA472JA021	4.7k	
	R756	D0GA221JA021	220	
	R757	D0GA472JA021	4.7k	
	R758	D0GA472JA021	4.7k	
	R759	D0GA103JA021	10k	
	R767	D0GA220JA021	22	
	R771	D0GA472JA021	4.7k	
	R772	D0GA472JA021	4.7k	
	R773	D0GA472JA021	4.7k	
	R800	D0YBR0000020	0	
	R801	D0YBR0000020	0	
	R802	D0YBR0000020	0	
	R803	ERJ2RKF2212	22.1k	
	R804	ERJ2RKF2212	22.1k	
	R805	D0GB103JA057	10k	
	R806	ERJ2RKF7322	73.2k	
	R807	ERJ2GEJ512	5.1k	
	R808	ERJ2RKF1201	1.2k	
	R809	D0GA103JA021	10k	
	R810	D0YBR0000020	0	
	R811	ERJ2RKF1272	12.7k	
	R812	D0YBR0000020	0	
	R813	D0YBR0000020	0	
	R814	D0GA472JA021	4.7k	
	R815	D0GA103JA021	10k	
	R816	D0GA102JA021	1k	
	R817	D0GA103JA021	10k	
	R818	D0GA104JA021	100k	
	R819	D0GA102JA021	1k	
	R820	D0GA102JA021	1k	
	R821	D0GA273JA015	27k	
	R822	D0GA473JA021	47k	
	R823	D0YBR0000020	0	
	R825	D0GA273JA015	27k	
	R826	D0GA473JA021	47k	
	R828	ERJ2GEJ564	560k	
	R829	D0GA473JA021	47k	
	R830	D0GA474JA021	470k	
	R831	D0GA474JA021	470k	
	R832	D0GA474JA021	470k	
	R833	D0GA104JA021	100k	
	R834	D0GA104JA021	100k	
	R835	D0GA103JA021	10k	
	R836	D0GA392JA015	3.9k	
	R837	D0GA472JA021	4.7k	
	R838	ERJ2GEJ471	470	S
	R839	D0GA104JA021	100k	
	R840	ERJ2RKF6341X	6.34k	
	R841	ERJ3GEYJ4R7	4.7	S
	R843	ERJ2RKF2200	220	
	R844	ERJ2RKF2200	220	
	R845	ERJ3GEYJ510	51	
	R846	ERJ2GEJ471	470	S
	R847	ERJ2GEJ471	470	S
	R851	D0GA103JA021	10k	
	R853	D0GA330JA015	33	
	R854	D0GA330JA015	33	
	L363	D0GA151JA021	150	
	L369	D0GA221JA021	220	
	L370	D0GA221JA021	220	
	L371	D0GA221JA021	220	
			(COMPONENTS PARTS)	
	RA305	EXB28V220JX	RESISTOR ARRAY	
	RA316	EXB28V470JX	RESISTOR ARRAY	
	RA321	EXB28V220JX	RESISTOR ARRAY	
	RA322	EXB28V220JX	RESISTOR ARRAY	
	RA323	EXB28V220JX	RESISTOR ARRAY	

Safety	Ref. No.	Part No.	Part Name & Description	Remarks
	RA324	EXB28V220JX	RESISTOR ARRAY	
	RA400	EXB28V220JX	RESISTOR ARRAY	
	RA401	EXB28V220JX	RESISTOR ARRAY	
	RA402	EXB28V220JX	RESISTOR ARRAY	
	RA403	EXB28V220JX	RESISTOR ARRAY	
	RA404	EXB28V470JX	RESISTOR ARRAY	
	RA405	EXB28V470JX	RESISTOR ARRAY	
	RA406	EXB28V470JX	RESISTOR ARRAY	
	RA407	EXB28V220JX	RESISTOR ARRAY	
	RA408	EXB28V220JX	RESISTOR ARRAY	
	RA409	EXB28V220JX	RESISTOR ARRAY	
	RA410	EXB28V220JX	RESISTOR ARRAY	
	RA411	EXB28V470JX	RESISTOR ARRAY	
	RA412	EXB28V470JX	RESISTOR ARRAY	
	RA413	EXB28V470JX	RESISTOR ARRAY	
	RA414	EXB28V330	RESISTOR ARRAY	
	RA415	EXB28V330	RESISTOR ARRAY	
	RA416	EXB28V330	RESISTOR ARRAY	
	RA417	EXB28V330	RESISTOR ARRAY	
	RA418	EXB28V330	RESISTOR ARRAY	
	RA419	EXB28V330	RESISTOR ARRAY	
	RA420	EXB28V330	RESISTOR ARRAY	
	RA421	EXB28V330	RESISTOR ARRAY	
	RA422	EXB28V330	RESISTOR ARRAY	
	RA423	EXB28V330	RESISTOR ARRAY	
	RA424	EXB28V330	RESISTOR ARRAY	
	RA425	EXB28V103JX	RESISTOR ARRAY	
	RA426	EXB28V103JX	RESISTOR ARRAY	
	RA427	EXB28V103JX	RESISTOR ARRAY	
	RA428	EXB28V103JX	RESISTOR ARRAY	
	RA500	EXB28V470JX	RESISTOR ARRAY	
	RA501	EXB28V470JX	RESISTOR ARRAY	
	RA502	EXB28V470JX	RESISTOR ARRAY	
			(RELAY)	
△	RLY100	K6B1CYY00005	RELAY	
			(VARISTORS)	
△	SA100	PFRZRA102P6T	VARISTOR (SURGE ABSORBER)	S
△	SA101	PFRZRA102P6T	VARISTOR (SURGE ABSORBER)	S
	SA102	J0LY00000157	VARISTOR (SURGE ABSORBER)	
			(FUSES)	
	F100	K5G102A00041	FUSE	S
△	F600	K5H202Y00003	FUSE	
			(CRYSTAL OSCILLATOR)	
	X300	H0J240500074	CRYSTAL OSCILLATOR	
	X301	H0J245500124	CRYSTAL OSCILLATOR	
	X303	H0A327200186	CRYSTAL OSCILLATOR	
	X500	H0J300500039	CRYSTAL OSCILLATOR	
	X750	H0J250500097	CRYSTAL OSCILLATOR	

18.2.7. Sensor Board

18.2.7.1. Operation Board (For MB2230EU)

Safety	Ref. No.	Part No.	Part Name & Description	Remarks
	PCB2	PNLPB223JT-A	OPERATION BOARD ASS'Y (RTL)	
			(IC)	
	IC1	C1ZBZ0004019	IC	
			(DIODES)	
	LED1	B3ABA0000633	DIODE (SI)	
	LED2	B3ABA0000633	DIODE (SI)	
	LED3	B3ABA0000633	DIODE (SI)	
	LED4	B3AAA0000534	DIODE (SI)	
	LED9	B3ABA0000633	DIODE (SI)	
			(CAPACITORS)	
	C1	F1H1C104A107	0.1	
	C2	F1H1C104A107	0.1	
	C3	F1H1C104A107	0.1	
	C4	ECJ1VB1H561K	560p	
	C6	ECUV1H101JCV	100p	S
	C7	F1H1H151A004	560p	

Safety	Ref. No.	Part No.	Part Name & Description	Remarks
	C8	ECUV1H102KBV	100p	S
	C10	F1H1C104A107	0.1	
	C11	F1H1C104A107	0.1	
	C12	ECJ1VB1H391K	390p	
	C13	ECUV1H101JCV	100p	S
	C14	ECUV1H101JCV	390p	
	C20	ECUV1H272KBV	100p	S
	C21	ECUV1H152KBV	100p	S
	C22	ECUV1H152KBV	0.0027	S
			(LCD)	
	CN1	PNWLMB1500RU	LIQUID CRYSTAL DISPLAY (CONNECTOR)	
	CN2	K1KA08B00243	CONNECTOR, 8PIN (RESISTORS)	
	J1	D0YBR0000020	METAL FILM OXIDE RESISTOR	
	J2	D0YBR0000020	METAL FILM OXIDE RESISTOR	
	J3	D0YBR0000020	METAL FILM OXIDE RESISTOR	
	J4	D0YBR0000020	METAL FILM OXIDE RESISTOR	
	J5	D0YBR0000020	12k	
	R1	ERJ3GSYJ101	100	S
	R2	ERJ3GSYJ101	100	S
	R3	ERJ3GSYJ101	100	S
	R4	D0GB151JA057	150	
	R5	ERJ3GSYJ123	12k	S
	R6	D0GB102JA057	1k	
	R7	D0GB102JA057	1k	
	R8	ERJ3GEYJ4R7	4.7	S
	R10	ERJ3GSYJ470	47	S
	R11	ERJ3GSYJ101	100	S
	R12	ERJ3GSYJ122	1.2k	S
	R13	ERJ3GSYJ101	100	S
	R14	ERJ3GSYJ332	3.3k	S
	R15	D0GB222JA057	2.2k	
	R20	ERJ3GSYJ181	180	S
	R21	ERJ3GSYJ181	180	S
	R22	ERJ3GSYJ181	180	S
	R23	ERJ3GSYJ181	180	S
	R24	ERJ3GSYJ181	180	S
	R25	ERJ3GSYJ181	180	S
	R26	ERJ3GSYJ181	180	S
	R27	ERJ3GSYJ181	180	S
	R28	PQ4R18XJ000	0	S
	R33	D0GB102JA057	1k	
	R36	ERJ3GSYJ101	100	S
	R38	D0YBR0000020	0	
			(SWITCHES)	
	SW1	K0H1BA000259	SPECIAL SWITCH	
	SW2	K0H1BA000259	SPECIAL SWITCH	
	SW3	K0H1BA000259	SPECIAL SWITCH	
	SW4	K0H1BA000259	SPECIAL SWITCH	
	SW5	K0H1BA000259	SPECIAL SWITCH	
	SW6	K0H1BA000259	SPECIAL SWITCH	
	SW8	K0H1BA000259	SPECIAL SWITCH	
	SW9	K0H1BA000259	SPECIAL SWITCH	
	SW10	K0H1BA000259	SPECIAL SWITCH	
	SW11	K0H1BA000259	SPECIAL SWITCH	
	SW12	K0H1BA000259	SPECIAL SWITCH	
	SW13	K0H1BA000259	SPECIAL SWITCH	
	SW14	K0H1BA000259	SPECIAL SWITCH	
	SW15	K0H1BA000259	SPECIAL SWITCH	
	SW16	K0H1BA000259	SPECIAL SWITCH	
	SW17	K0H1BA000259	SPECIAL SWITCH	
	SW18	K0H1BA000259	SPECIAL SWITCH	
	SW19	K0H1BA000259	SPECIAL SWITCH	
	SW20	K0H1BA000259	SPECIAL SWITCH	
	SW21	K0H1BA000259	SPECIAL SWITCH	
	SW22	K0H1BA000259	SPECIAL SWITCH	
	SW23	K0H1BA000259	SPECIAL SWITCH	
	SW24	K0H1BA000259	SPECIAL SWITCH	
	SW25	K0H1BA000259	SPECIAL SWITCH	

Safety	Ref. No.	Part No.	Part Name & Description	Remarks
	SW26	K0H1BA000259	SPECIAL SWITCH	
	SW27	K0H1BA000259	SPECIAL SWITCH	
	SW28	K0H1BA000259	SPECIAL SWITCH	
	SW29	K0H1BA000259	SPECIAL SWITCH	
	SW30	K0H1BA000259	SPECIAL SWITCH	
	SW31	K0H1BA000259	SPECIAL SWITCH	
	SW32	K0H1BA000259	SPECIAL SWITCH	

18.2.7.2. Operation Board (For MB2270EU)

Safety	Ref. No.	Part No.	Part Name & Description	Remarks
	PCB2	PNLPB227JT-A	OPERATION BOARD ASS'Y (RTL)	
			(IC)	
	IC1	C1ZBZ0004019	IC (DIODES)	
	LED1	B3ABA0000633	DIODE (SI)	
	LED2	B3ABA0000633	DIODE (SI)	
	LED3	B3ABA0000633	DIODE (SI)	
	LED4	B3AAA0000534	DIODE (SI)	
	LED5	B3ABA0000633	DIODE (SI)	
	LED9	B3ABA0000633	DIODE (SI)	
			(CAPACITORS)	
	C1	F1H1C104A107	0.1	
	C2	F1H1C104A107	0.1	
	C3	F1H1C104A107	0.1	
	C4	ECJ1VB1H561K	560p	
	C6	ECUV1H101JCV	100p	S
	C7	F1H1H151A004	150p	
	C8	ECUV1H102KBV	0.001	S
	C10	F1H1C104A107	0.1	
	C11	F1H1C104A107	0.1	
	C12	ECJ1VB1H391K	390p	
	C13	ECUV1H101JCV	100p	S
	C14	ECUV1H101JCV	100p	S
	C20	ECUV1H272KBV	0.0027	S
	C21	ECUV1H152KBV	0.0015	S
	C22	ECUV1H152KBV	0.0015	S
			(LCD)	
	CN1	PNWLMB1500RU	LIQUID CRYSTAL DISPLAY (CONNECTOR)	
	CN2	K1KA08B00243	CONNECTOR, 8PIN (RESISTORS)	
	J1	D0YBR0000020	METAL FILM OXIDE RESISTOR	
	J2	D0YBR0000020	METAL FILM OXIDE RESISTOR	
	J3	D0YBR0000020	METAL FILM OXIDE RESISTOR	
	J4	D0YBR0000020	METAL FILM OXIDE RESISTOR	
	J5	D0YBR0000020	METAL FILM OXIDE RESISTOR	
	R1	ERJ3GSYJ101	100	S
	R2	ERJ3GSYJ101	100	S
	R3	ERJ3GSYJ101	100	S
	R4	D0GB151JA057	150	
	R5	ERJ3GSYJ123	12k	S
	R6	D0GB102JA057	1k	
	R7	D0GB102JA057	1k	
	R8	ERJ3GEYJ4R7	4.7	S
	R10	ERJ3GSYJ470	47	S
	R11	ERJ3GSYJ101	100	S
	R12	ERJ3GSYJ122	1.2k	S
	R13	ERJ3GSYJ101	100	S
	R14	ERJ3GSYJ332	3.3k	S
	R15	D0GB222JA057	2.2k	
	R20	ERJ3GSYJ181	180	S
	R21	ERJ3GSYJ181	180	S
	R22	ERJ3GSYJ181	180	S
	R23	ERJ3GSYJ181	180	S
	R24	ERJ3GSYJ181	180	S
	R25	ERJ3GSYJ181	180	S

Safety	Ref. No.	Part No.	Part Name & Description	Remarks
	R26	ERJ3GSYJ181	180	S
	R27	ERJ3GSYJ181	180	S
	R33	D0GB102JA057	1k	
	R36	ERJ3GSYJ101	100	S
	R37	ERJ3GSYJ101	100	S
	R38	D0YBR0000020	0	
			(SWITCHES)	
	SW1	K0H1BA000259	SPECIAL SWITCH	
	SW2	K0H1BA000259	SPECIAL SWITCH	
	SW3	K0H1BA000259	SPECIAL SWITCH	
	SW4	K0H1BA000259	SPECIAL SWITCH	
	SW5	K0H1BA000259	SPECIAL SWITCH	
	SW6	K0H1BA000259	SPECIAL SWITCH	
	SW7	K0H1BA000259	SPECIAL SWITCH	
	SW8	K0H1BA000259	SPECIAL SWITCH	
	SW9	K0H1BA000259	SPECIAL SWITCH	
	SW10	K0H1BA000259	SPECIAL SWITCH	
	SW11	K0H1BA000259	SPECIAL SWITCH	
	SW12	K0H1BA000259	SPECIAL SWITCH	
	SW13	K0H1BA000259	SPECIAL SWITCH	
	SW14	K0H1BA000259	SPECIAL SWITCH	
	SW15	K0H1BA000259	SPECIAL SWITCH	
	SW16	K0H1BA000259	SPECIAL SWITCH	
	SW17	K0H1BA000259	SPECIAL SWITCH	
	SW18	K0H1BA000259	SPECIAL SWITCH	
	SW19	K0H1BA000259	SPECIAL SWITCH	
	SW20	K0H1BA000259	SPECIAL SWITCH	
	SW21	K0H1BA000259	SPECIAL SWITCH	
	SW22	K0H1BA000259	SPECIAL SWITCH	
	SW23	K0H1BA000259	SPECIAL SWITCH	
	SW24	K0H1BA000259	SPECIAL SWITCH	
	SW25	K0H1BA000259	SPECIAL SWITCH	
	SW26	K0H1BA000259	SPECIAL SWITCH	
	SW27	K0H1BA000259	SPECIAL SWITCH	
	SW28	K0H1BA000259	SPECIAL SWITCH	
	SW29	K0H1BA000259	SPECIAL SWITCH	
	SW30	K0H1BA000259	SPECIAL SWITCH	
	SW31	K0H1BA000259	SPECIAL SWITCH	
	SW32	K0H1BA000259	SPECIAL SWITCH	

18.2.7.3. Operation Board (For MB2515EU)

Safety	Ref. No.	Part No.	Part Name & Description	Remarks
	PCB2	PNLPB251JT-A	OPERATION BOARD ASS'Y (RTL)	
			(IC)	
	IC1	C1ZBZ0004019	IC	
			(TRANSISTORS)	
	Q1	B1ABGE000011	TRANSISTOR (SI)	
	Q2	DRA5143E0L	TRANSISTOR (SI)	
	Q3	DRC5123J0L	TRANSISTOR (SI)	
	Q4	DRC5144E0L	TRANSISTOR (SI)	
			(DIODES)	
	LED6	B3ABA0000633	DIODE (SI)	
	LED7	B3ABA0000633	DIODE (SI)	
	LED9	B3ABA0000633	DIODE (SI)	
			(CAPACITORS)	
	C1	F1H1C104A107	0.1	
	C2	F1H1C104A107	0.1	
	C3	F1H1C104A107	0.1	
	C4	ECJ1VB1H561K	560p	
	C6	ECJ1VB1H561K	560p	
	C7	F1H1H151A004	150p	
	C8	ECUV1H102KBV	0.001	S
	C12	ECJ1VB1H391K	390p	
	C13	ECUV1H101JCV	100p	S
	C14	ECUV1H101JCV	100p	S
	C16	F1H1H100A831	10p	
	C18	F1H1A225A025	2.2	
	C19	F1H1A225A025	2.2	
	C23	F1H1A224A046	0.22	

Safety	Ref. No.	Part No.	Part Name & Description	Remarks
			(CONNECTORS)	
	CN2	K1KA08B00243	CONNECTOR, 8PIN	
	CN3	K1MY12BA0516	CONNECTOR, 12PIN	
			(RESISTORS)	
	J1	D0YBR0000020	0	
	J2	D0YBR0000020	0	
	J3	D0YBR0000020	0	
	J4	D0YBR0000020	0	
	J5	D0YBR0000020	0	
	R1	ERJ3GSYJ101	100	S
	R3	ERJ3GSYJ101	100	S
	R5	ERJ3GSYJ123	12k	S
	R11	ERJ3GSYJ101	100	S
	R12	ERJ3GSYJ101	100	S
	R13	ERJ3GSYJ101	100	S
	R14	ERJ3GSYJ332	3.3k	S
	R15	ERJ3GSYJ123	12k	S
	R16	ERJ3GSYJ101	100	S
	R17	D0GB472JA057	4.7k	
	R18	D0GB472JA057	4.7k	
	R19	D0GB474JA041	470k	
	R20	ERJ3GSYJ181	180	S
	R21	ERJ3GSYJ181	180	S
	R22	ERJ3GSYJ181	180	S
	R23	ERJ3GSYJ181	180	S
	R24	ERJ3GSYJ181	180	S
	R25	ERJ3GSYJ181	180	S
	R26	ERJ3GSYJ181	180	S
	R27	ERJ3GSYJ181	180	S
	R33	D0GB102JA057	1k	
	R35	D0GB151JA057	150	
	R36	ERJ3GSYJ101	100	S
	R39	D0YBR0000020	0	
			(BUZZER)	
	BZ1	L0DAYA000010	BUZZER	
			(SWITCHES)	
	SW1	K0H1BA000259	SPECIAL SWITCH	
	SW3	K0H1BA000259	SPECIAL SWITCH	
	SW4	K0H1BA000259	SPECIAL SWITCH	
	SW5	K0H1BA000259	SPECIAL SWITCH	
	SW6	K0H1BA000259	SPECIAL SWITCH	
	SW8	K0H1BA000259	SPECIAL SWITCH	
	SW9	K0H1BA000259	SPECIAL SWITCH	
	SW10	K0H1BA000259	SPECIAL SWITCH	
	SW11	K0H1BA000259	SPECIAL SWITCH	
	SW12	K0H1BA000259	SPECIAL SWITCH	
	SW13	K0H1BA000259	SPECIAL SWITCH	
	SW14	K0H1BA000259	SPECIAL SWITCH	
	SW15	K0H1BA000259	SPECIAL SWITCH	
	SW16	K0H1BA000259	SPECIAL SWITCH	
	SW17	K0H1BA000259	SPECIAL SWITCH	
	SW19	K0H1BA000259	SPECIAL SWITCH	
	SW20	K0H1BA000259	SPECIAL SWITCH	
	SW21	K0H1BA000259	SPECIAL SWITCH	
	SW22	K0H1BA000259	SPECIAL SWITCH	
	SW23	K0H1BA000259	SPECIAL SWITCH	
	SW24	K0H1BA000259	SPECIAL SWITCH	
	SW25	K0H1BA000259	SPECIAL SWITCH	
	SW26	K0H1BA000259	SPECIAL SWITCH	
	SW27	K0H1BA000259	SPECIAL SWITCH	
	SW28	K0H1BA000259	SPECIAL SWITCH	
	SW29	K0H1BA000259	SPECIAL SWITCH	
	SW30	K0H1BA000259	SPECIAL SWITCH	
	SW32	K0H1BA000259	SPECIAL SWITCH	

18.2.7.4. Operation Board (For MB2545EU)

Safety	Ref. No.	Part No.	Part Name & Description	Remarks
	PCB2	PNLPB254JT-A	OPERATION BOARD ASS'Y (RTL)	
			(IC)	
	IC1	C1ZBZ0004019	IC	

Safety	Ref. No.	Part No.	Part Name & Description	Remarks
			(TRANSISTORS)	
	Q2	DRA5143E0L	TRANSISTOR (SI)	
	Q3	DRC5123J0L	TRANSISTOR (SI)	
	Q4	DRC5144E0L	TRANSISTOR (SI)	
			(DIODES)	
	LED1	B3ABA0000633	DIODE (SI)	
	LED2	B3ABA0000633	DIODE (SI)	
	LED3	B3ABA0000633	DIODE (SI)	
	LED4	B3AAA0000534	DIODE (SI)	
	LED9	B3ABA0000633	DIODE (SI)	
			(CAPACITORS)	
	C1	F1H1C104A107	0.1	
	C2	F1H1C104A107	0.1	
	C3	F1H1C104A107	0.1	
	C4	ECJ1VB1H561K	560p	
	C6	ECJ1VB1H561K	560p	
	C7	F1H1H151A004	150p	
	C8	ECUV1H102KBV	0.001	S
	C12	ECJ1VB1H391K	390p	
	C13	ECUV1H101JCV	100p	S
	C14	ECUV1H101JCV	100p	S
	C18	F1H1A225A025	2.2	
	C19	F1H1A225A025	2.2	
			(CONNECTORS)	
	CN2	K1KA08B00243	CONNECTOR, 8PIN	
	CN3	K1MY12BA0516	CONNECTOR, 12PIN	
			(RESISTORS)	
	J1	D0YBR0000020	METAL FILM OXIDE RESIS-TOR	
	J2	D0YBR0000020	METAL FILM OXIDE RESIS-TOR	
	J3	D0YBR0000020	METAL FILM OXIDE RESIS-TOR	
	J4	D0YBR0000020	METAL FILM OXIDE RESIS-TOR	
	J5	D0YBR0000020	METAL FILM OXIDE RESIS-TOR	
	R1	ERJ3GSYJ101	100	S
	R2	ERJ3GSYJ101	100	S
	R3	ERJ3GSYJ101	100	S
	R4	D0GB151JA057	150	S
	R5	ERJ3GSYJ123	12k	S
	R11	ERJ3GSYJ101	100	S
	R12	ERJ3GSYJ101	100	S
	R13	ERJ3GSYJ101	100	S
	R14	ERJ3GSYJ332	3.3k	S
	R15	ERJ3GSYJ123	12k	S
	R18	D0GB472JA057	4.7k	
	R20	ERJ3GSYJ181	180	S
	R21	ERJ3GSYJ181	180	S
	R22	ERJ3GSYJ181	180	S
	R23	ERJ3GSYJ181	180	S
	R24	ERJ3GSYJ181	180	S
	R25	ERJ3GSYJ181	180	S
	R26	ERJ3GSYJ181	180	S
	R27	ERJ3GSYJ181	180	S
	R33	D0GB102JA057	1k	
	R35	D0GB151JA057	150	
	R36	ERJ3GSYJ101	100	S
	R39	D0YBR0000020	0	
			(SWITCHES)	
	SW1	K0H1BA000259	SPECIAL SWITCH	
	SW2	K0H1BA000259	SPECIAL SWITCH	
	SW3	K0H1BA000259	SPECIAL SWITCH	
	SW4	K0H1BA000259	SPECIAL SWITCH	
	SW5	K0H1BA000259	SPECIAL SWITCH	
	SW6	K0H1BA000259	SPECIAL SWITCH	
	SW8	K0H1BA000259	SPECIAL SWITCH	
	SW9	K0H1BA000259	SPECIAL SWITCH	
	SW10	K0H1BA000259	SPECIAL SWITCH	
	SW11	K0H1BA000259	SPECIAL SWITCH	
	SW12	K0H1BA000259	SPECIAL SWITCH	
	SW13	K0H1BA000259	SPECIAL SWITCH	
	SW14	K0H1BA000259	SPECIAL SWITCH	

Safety	Ref. No.	Part No.	Part Name & Description	Remarks
	SW15	K0H1BA000259	SPECIAL SWITCH	
	SW16	K0H1BA000259	SPECIAL SWITCH	
	SW17	K0H1BA000259	SPECIAL SWITCH	
	SW18	K0H1BA000259	SPECIAL SWITCH	
	SW19	K0H1BA000259	SPECIAL SWITCH	
	SW20	K0H1BA000259	SPECIAL SWITCH	
	SW21	K0H1BA000259	SPECIAL SWITCH	
	SW22	K0H1BA000259	SPECIAL SWITCH	
	SW23	K0H1BA000259	SPECIAL SWITCH	
	SW24	K0H1BA000259	SPECIAL SWITCH	
	SW25	K0H1BA000259	SPECIAL SWITCH	
	SW26	K0H1BA000259	SPECIAL SWITCH	
	SW27	K0H1BA000259	SPECIAL SWITCH	
	SW28	K0H1BA000259	SPECIAL SWITCH	
	SW29	K0H1BA000259	SPECIAL SWITCH	
	SW30	K0H1BA000259	SPECIAL SWITCH	
	SW31	K0H1BA000259	SPECIAL SWITCH	
	SW32	K0H1BA000259	SPECIAL SWITCH	

18.2.7.5. Operation Board (For MB2575EU)

Safety	Ref. No.	Part No.	Part Name & Description	Remarks
	PCB2	PNLPB257JT-A	OPERATION BOARD ASS'Y (RTL)	
			(IC)	
	IC1	C1ZB20004019	IC	
			(TRANSISTORS)	
	Q2	DRA5143E0L	TRANSISTOR (SI)	
	Q3	DRC5123J0L	TRANSISTOR (SI)	
	Q4	DRC5144E0L	TRANSISTOR (SI)	
			(DIODES)	
	LED1	B3ABA0000633	DIODE (SI)	
	LED2	B3ABA0000633	DIODE (SI)	
	LED3	B3ABA0000633	DIODE (SI)	
	LED4	B3AAA0000534	DIODE (SI)	
	LED5	B3ABA0000633	DIODE (SI)	
	LED9	B3ABA0000633	DIODE (SI)	
			(CAPACITORS)	
	C1	F1H1C104A107	0.1	
	C2	F1H1C104A107	0.1	
	C3	F1H1C104A107	0.1	
	C4	ECJ1VB1H561K	560p	
	C6	ECJ1VB1H561K	560p	
	C7	F1H1H151A004	150p	
	C8	ECUV1H102KBV	0.001	S
	C12	ECJ1VB1H391K	390p	
	C13	ECUV1H101JCV	100p	S
	C14	ECUV1H101JCV	100p	S
	C18	F1H1A225A025	2.2	
	C19	F1H1A225A025	2.2	
			(CONNECTORS)	
	CN2	K1KA08B00243	CONNECTOR, 8PIN	
	CN3	K1MY12BA0516	CONNECTOR, 12PIN	
			(RESISTORS)	
	J1	D0YBR0000020	METAL FILM OXIDE RESIS-TOR	
	J2	D0YBR0000020	METAL FILM OXIDE RESIS-TOR	
	J3	D0YBR0000020	METAL FILM OXIDE RESIS-TOR	
	J4	D0YBR0000020	METAL FILM OXIDE RESIS-TOR	
	J5	D0YBR0000020	METAL FILM OXIDE RESIS-TOR	
	R1	ERJ3GSYJ101	100	S
	R2	ERJ3GSYJ101	100	S
	R3	ERJ3GSYJ101	100	S
	R4	D0GB151JA057	150	
	R5	ERJ3GSYJ123	12k	S
	R11	ERJ3GSYJ101	100	S
	R12	ERJ3GSYJ101	100	S
	R13	ERJ3GSYJ101	100	S
	R14	ERJ3GSYJ332	3.3k	S

Safety	Ref. No.	Part No.	Part Name & Description	Remarks
	R15	ERJ3GSYJ123	12k	S
	R18	D0GB472JA057	4.7k	
	R20	ERJ3GSYJ181	180	S
	R21	ERJ3GSYJ181	180	S
	R22	ERJ3GSYJ181	180	S
	R23	ERJ3GSYJ181	180	S
	R24	ERJ3GSYJ181	180	S
	R25	ERJ3GSYJ181	180	S
	R26	ERJ3GSYJ181	180	S
	R27	ERJ3GSYJ181	180	S
	R33	D0GB102JA057	1k	
	R35	D0GB151JA057	150	
	R36	ERJ3GSYJ101	100	S
	R37	ERJ3GSYJ101	100	S
	R39	D0YBR0000020	0	
			(SWITCHES)	
	SW1	K0H1BA000259	SPECIAL SWITCH	
	SW2	K0H1BA000259	SPECIAL SWITCH	
	SW3	K0H1BA000259	SPECIAL SWITCH	
	SW4	K0H1BA000259	SPECIAL SWITCH	
	SW5	K0H1BA000259	SPECIAL SWITCH	
	SW6	K0H1BA000259	SPECIAL SWITCH	
	SW7	K0H1BA000259	SPECIAL SWITCH	
	SW8	K0H1BA000259	SPECIAL SWITCH	
	SW9	K0H1BA000259	SPECIAL SWITCH	
	SW10	K0H1BA000259	SPECIAL SWITCH	
	SW11	K0H1BA000259	SPECIAL SWITCH	
	SW12	K0H1BA000259	SPECIAL SWITCH	
	SW13	K0H1BA000259	SPECIAL SWITCH	
	SW14	K0H1BA000259	SPECIAL SWITCH	
	SW15	K0H1BA000259	SPECIAL SWITCH	
	SW16	K0H1BA000259	SPECIAL SWITCH	
	SW17	K0H1BA000259	SPECIAL SWITCH	
	SW18	K0H1BA000259	SPECIAL SWITCH	
	SW19	K0H1BA000259	SPECIAL SWITCH	
	SW20	K0H1BA000259	SPECIAL SWITCH	
	SW21	K0H1BA000259	SPECIAL SWITCH	
	SW22	K0H1BA000259	SPECIAL SWITCH	
	SW23	K0H1BA000259	SPECIAL SWITCH	
	SW24	K0H1BA000259	SPECIAL SWITCH	
	SW25	K0H1BA000259	SPECIAL SWITCH	
	SW26	K0H1BA000259	SPECIAL SWITCH	
	SW27	K0H1BA000259	SPECIAL SWITCH	
	SW28	K0H1BA000259	SPECIAL SWITCH	
	SW29	K0H1BA000259	SPECIAL SWITCH	
	SW30	K0H1BA000259	SPECIAL SWITCH	
	SW31	K0H1BA000259	SPECIAL SWITCH	
	SW32	K0H1BA000259	SPECIAL SWITCH	

18.2.7.6. Operation Board (For MB310EU)

Safety	Ref. No.	Part No.	Part Name & Description	Remarks
	PCB2	PNLPB310JT-A	OPERATION BOARD ASS'Y (RTL)	
			(IC)	
	IC1	C1ZBZ0004019	IC	
			(TRANSISTORS)	
	Q2	DRA5143E0L	TRANSISTOR (SI)	
	Q3	DRC5123J0L	TRANSISTOR (SI)	
	Q4	DRC5144E0L	TRANSISTOR (SI)	
			(DIODES)	
	LED1	B3ABA0000633	DIODE (SI)	
	LED2	B3ABA0000633	DIODE (SI)	
	LED3	B3ABA0000633	DIODE (SI)	
	LED4	B3AAA0000534	DIODE (SI)	
	LED9	B3ABA0000633	DIODE (SI)	
			(CAPACITORS)	
	C1	F1H1C104A107	0.1	
	C2	F1H1C104A107	0.1	
	C3	F1H1C104A107	0.1	
	C4	ECJ1VB1H561K	560p	
	C6	ECJ1VB1H561K	560p	

Safety	Ref. No.	Part No.	Part Name & Description	Remarks
	C7	F1H1H151A004	150p	
	C8	ECUV1H102KBV	0.001	S
	C12	ECJ1VB1H391K	390p	
	C13	ECUV1H101JCV	100p	S
	C14	ECUV1H101JCV	100p	S
	C18	F1H1A225A025	2.2	
	C19	F1H1A225A025	2.2	
			(CONNECTORS)	
	CN2	K1KA08B00243	CONNECTOR, 8PIN	
	CN3	K1MY12BA0516	CONNECTOR, 12PIN	
			(RESISTORS)	
	J1	D0YBR0000020	METAL FILM OXIDE RESISTOR	
	J2	D0YBR0000020	METAL FILM OXIDE RESISTOR	
	J3	D0YBR0000020	METAL FILM OXIDE RESISTOR	
	J4	D0YBR0000020	METAL FILM OXIDE RESISTOR	
	J5	D0YBR0000020	METAL FILM OXIDE RESISTOR	
	R1	ERJ3GSYJ101	100	S
	R2	ERJ3GSYJ101	100	S
	R3	ERJ3GSYJ101	100	S
	R4	D0GB151JA057	150	0
	R5	ERJ3GSYJ123	12k	S
	R11	ERJ3GSYJ101	100	S
	R12	ERJ3GSYJ101	100	S
	R13	ERJ3GSYJ101	100	S
	R14	ERJ3GSYJ332	3.3k	S
	R15	ERJ3GSYJ123	12k	S
	R18	D0GB472JA057	4.7k	0
	R20	ERJ3GSYJ181	180	S
	R21	ERJ3GSYJ181	180	S
	R22	ERJ3GSYJ181	180	S
	R23	ERJ3GSYJ181	180	S
	R24	ERJ3GSYJ181	180	S
	R25	ERJ3GSYJ181	180	S
	R26	ERJ3GSYJ181	180	S
	R27	ERJ3GSYJ181	180	S
	R33	D0GB102JA057	1k	0
	R35	D0GB151JA057	150	0
	R36	ERJ3GSYJ101	100	S
	R39	D0YBR0000020	0	0
			(SWITCHES)	
	SW1	K0H1BA000259	SPECIAL SWITCH	
	SW2	K0H1BA000259	SPECIAL SWITCH	
	SW3	K0H1BA000259	SPECIAL SWITCH	
	SW4	K0H1BA000259	SPECIAL SWITCH	
	SW5	K0H1BA000259	SPECIAL SWITCH	
	SW6	K0H1BA000259	SPECIAL SWITCH	
	SW8	K0H1BA000259	SPECIAL SWITCH	
	SW9	K0H1BA000259	SPECIAL SWITCH	
	SW10	K0H1BA000259	SPECIAL SWITCH	
	SW11	K0H1BA000259	SPECIAL SWITCH	
	SW12	K0H1BA000259	SPECIAL SWITCH	
	SW13	K0H1BA000259	SPECIAL SWITCH	
	SW14	K0H1BA000259	SPECIAL SWITCH	
	SW15	K0H1BA000259	SPECIAL SWITCH	
	SW16	K0H1BA000259	SPECIAL SWITCH	
	SW17	K0H1BA000259	SPECIAL SWITCH	
	SW18	K0H1BA000259	SPECIAL SWITCH	
	SW19	K0H1BA000259	SPECIAL SWITCH	
	SW20	K0H1BA000259	SPECIAL SWITCH	
	SW21	K0H1BA000259	SPECIAL SWITCH	
	SW22	K0H1BA000259	SPECIAL SWITCH	
	SW23	K0H1BA000259	SPECIAL SWITCH	
	SW24	K0H1BA000259	SPECIAL SWITCH	
	SW25	K0H1BA000259	SPECIAL SWITCH	
	SW26	K0H1BA000259	SPECIAL SWITCH	
	SW27	K0H1BA000259	SPECIAL SWITCH	
	SW28	K0H1BA000259	SPECIAL SWITCH	
	SW29	K0H1BA000259	SPECIAL SWITCH	
	SW30	K0H1BA000259	SPECIAL SWITCH	

Safety	Ref. No.	Part No.	Part Name & Description	Remarks
	SW31	K0H1BA000259	SPECIAL SWITCH	
	SW32	K0H1BA000259	SPECIAL SWITCH	

18.2.7.7. Pick Up Relay Board

Safety	Ref. No.	Part No.	Part Name & Description	Remarks
	PCB3	PNLPB223JT-B	PICK SENSOR ASS'Y (RTL)	
			(CAPACITORS)	
	C57	ECUV1H102KBV	0.001	S
	C58	ECUV1H102KBV	0.001	S
	C64	ECUV1H102KBV	0.001	S
			(CONNECTOR)	
	CN50	K1KA06A00428	CONNECTOR, 6PIN	
			(RESISTORS)	
	R50	ERJ3GSYJ181	180	S
	R52	ERJ3GSYJ181	180	S
	R61	ERJ3GSYJ181	180	S
			(PHOTO ELECTRIC TRANS-DUCERS)	
	PI50	B3NAA0000106	PHOTO ELECTRIC TRANS-DUCER	
	PI51	B3NAA0000106	PHOTO ELECTRIC TRANS-DUCER	
	PI52	B3NAA0000106	PHOTO ELECTRIC TRANS-DUCER	
			(THERMISTOR)	
	TH50	D4CCY1030002	THERMISTOR	

18.2.7.8. Print Sensor Relay Board / Toner Sensor Board

Safety	Ref. No.	Part No.	Part Name & Description	Remarks
	PCB4	PNWP3B2230JT	TONER SENSOR BOARD ASS'Y (RTL)	
			(IC)	
	IC50	B4ABC0000053	IC	
			(CAPACITORS)	
	C56	ECUV1H102KBV	0.001	S
	C59	ECUV1H102KBV	0.001	S
	C63	ECUV1H102KBV	0.001	S
	C65	F1H1A105A025	1	0
			(CONNECTOR)	
	CN54	K1KA06A00428	CONNECTOR, 6PIN	
			(RESISTORS)	
	R58	ERJ3GSYJ181	180	S
	R59	ERJ3GSYJ181	180	S
	R60	ERJ3GSYJ181	180	S
			(PHOTO ELECTRIC TRANS-DUCERS)	
	PI53	B3NAA0000106	PHOTO ELECTRIC TRANS-DUCER	
	PI54	B3NAA0000106	PHOTO ELECTRIC TRANS-DUCER	
	PI55	B3NAA0000106	PHOTO ELECTRIC TRANS-DUCER	

18.2.7.9. Interlock Switch Board

Safety	Ref. No.	Part No.	Part Name & Description	Remarks
	PCB5	PNLPB223JT-D	INTERLOCK SWITCH BOARD ASS'Y (RTL)	
			(CONNECTORS)	
	CN51	K1KA06A00428	CONNECTOR, 6PIN	
			(SWITCHES)	
	SW50	K0KACF000064	MICRO SWITCH	
	SW51	K0KACF000064	MICRO SWITCH	

18.2.7.10. Center Relay Board

Safety	Ref. No.	Part No.	Part Name & Description	Remarks
	PCB6	PNLPB223JT-E	GEAR RELAY BOARD ASS'Y (RTL)	
			(DIODES)	
	D51	DA2J10100L	DIODE (SI)	
	D56	PJVDJADAN202	DIODE (SI)	S
	D57	DA2J10100L	DIODE (SI)	
			(CONNECTORS)	
	CN58	K1KA08A00440	CONNECTOR, 8PIN	
	CN59	K1KA02AA0193	CONNECTOR, 2PIN	
	CN63	K1KA02A00745	CONNECTOR, 2PIN	
	CN65	K1KA02A00587	CONNECTOR, 2PIN	
	CN72	K1KA03AA0193	CONNECTOR, 3PIN	
	CN76	K1KA02AA0224	CONNECTOR, 2PIN	

18.2.7.11. Rear Sensor Board

Safety	Ref. No.	Part No.	Part Name & Description	Remarks
	PCB7	PNLPB223JT-F	REAR SENSOR BOARD ASS'Y (RTL)	
			(CAPACITOR)	
	C60	ECUV1H102KBV	0.001	S
			(CONNECTOR)	
	CN53	K1KA03B00201	CONNECTOR, 3PIN	
			(RESISTOR)	
	R54	ERJ3GSYJ181	180	S
			(PHOTO ELECTRIC TRANS-DUCER)	
	PI57	B3NAA0000106	PHOTO ELECTRIC TRANS-DUCER	

18.2.7.12. Fuser Board

Safety	Ref. No.	Part No.	Part Name & Description	Remarks
	PCB8	PNLPB223JT-H	FUSER BOARD ASS'Y (RTL)	
			(CAPACITORS)	
	C55	ECUV1H102KBV	0.001	S
			(CONNECTORS)	
	CN52	K1KA04B00225	CONNECTOR, 4PIN	
	CN70	K1KA02AA0193	CONNECTOR, 2PIN	
			(RESISTOR)	
	R51	ERJ3GSYJ181	180	S
			(PHOTO ELECTRIC TRANS-DUCER)	
	PI58	B3NAA0000106	PHOTO ELECTRIC TRANS-DUCER	

18.2.7.13. Varistor Board

Safety	Ref. No.	Part No.	Part Name & Description	Remarks
	PCB9	PNLPB223JT-J	VARISTOR BOARD ASS'Y (RTL)	
			(DIODE)	
	D52	ERZVA7D271	DIODE (SI)	

18.2.7.14. OPC Contact Board

Safety	Ref. No.	Part No.	Part Name & Description	Remarks
	PCB10	PNLPB223JT-K	OPC CONTACT BOARD ASS'Y (RTL)	
			(CONNECTOR)	
	CN79	K1KA02A00587	CONNECTOR, 2PIN	

18.2.7.15. Toner Contact Board

Safety	Ref. No.	Part No.	Part Name & Description	Remarks
	PCB11	PNLPB223JT-L	TONER CONTACT BOARD ASS'Y (RTL)	
			(CONNECTOR)	
	CN80	K1KA02A00745	CONNECTOR, 2PIN	

18.2.7.16. DOCU Sensor Board

Safety	Ref. No.	Part No.	Part Name & Description	Remarks
	PCB12	PNLPB223JT-M	DOCUMENT SENSOR BOARD ASS'Y (RTL)	
			(CAPACITOR)	
	C51	ECUV1H102KBV	0.001	S
			(CONNECTOR)	
	CN62	K1KA03BA0061	CONNECTOR, 3PIN	
			(RESISTOR)	
	R57	ERJ3GSYJ181	180	S
			(PHOTO ELECTRIC TRANSDUCER)	
	PI60	B3NAA0000106	PHOTO ELECTRIC TRANSDUCER	

18.2.7.17. RPS Board

Safety	Ref. No.	Part No.	Part Name & Description	Remarks
	PCB13	PNLPB223JT-N	READ POSITION SENSOR BOARD ASS'Y (RTL)	
			(CAPACITORS)	
	C54	ECUV1H102KBV	0.001	S
			(CONNECTOR)	
	CN61	K1KA03A00612	CONNECTOR, 3PIN	
			(RESISTOR)	
	R55	ERJ3GSYJ181	180	S
			(PHOTO ELECTRIC TRANSDUCER)	
	PI59	B3NAA0000105	PHOTO ELECTRIC TRANSDUCER	

18.2.7.18. ADF Relay Board

Safety	Ref. No.	Part No.	Part Name & Description	Remarks
	PCB14	PNLPB223JT-P	ADF RELAY BOARD ASS'Y (RTL) (MB2230/2270EU only)	
	PCB14	PNLPB257JT-P	ADF RELAY BOARD ASS'Y (RTL) (MB2515/2545/2575/310EU only)	
			(CONNECTORS)	
	CN56	K1KA03A00612	CONNECTOR, 3PIN	
	CN57	K1KA03AA0193	CONNECTOR, 3PIN	
	CN66	K1KA09A00204	CONNECTOR, 9PIN (MB2230/2270EU only)	
	CN66	K1KA12A00315	CONNECTOR, 12PIN (MB2515/2545/2575/310EU only)	
	CN67	K1KA04A00527	CONNECTOR, 4PIN	
	CN68	K1KA02AA0193	CONNECTOR, 2PIN (MB2515/2545/2575/310EU only)	
	CN69	K1KA02A00587	CONNECTOR, 2PIN (MB2515/2545/2575/310EU only)	
	CN73	K1KA03A00495	CONNECTOR, 3PIN (MB2515/2545/2575/310EU only)	

18.2.7.19. Power Switch Board

Safety	Ref. No.	Part No.	Part Name & Description	Remarks
	PCB15	PNLPB223JT-Q	POWER SWITCH BOARD ASS'Y (RTL) (MB2230/2270EU only)	
	PCB15	PNLPB257JT-Q	POWER SWITCH BOARD ASS'Y (RTL) (MB2515/2545/2575/310EU only)	
			(CAPACITOR)	
	C66	ECUV1A474KBV	0.47 (MB2515/2545/2575/310EU only)	S
			(CONNECTORS)	
	CN74	K1KA03B00201	CONNECTOR, 3PIN	
	CN77	K1KA05BA0061	CONNECTOR, 5PIN (MB2515/2545/2575/310EU only)	
	CN78	K1FY104A0037	CONNECTOR, 4PIN (MB2515/2545/2575/310EU only)	
			(COILS)	
	L54	PQLQR2KB113T	COIL (MB2515/2545/2575/310EU only)	S
	L55	PQLQR2KB113T	COIL	S
			(SWITCHES)	
	SW56	R0H1BA000259	SPECIAL SWITCH	

18.2.7.20. RADF Board(For MB2515/2545/2575/310EU)

Safety	Ref. No.	Part No.	Part Name & Description	Remarks
	PCB16	PNLPB257JT-R	ADF JAM SENSOR BOARD ASS'Y (RTL)	
			(CAPACITOR)	
	C67	ECUV1H102KBV	0.001	S
			(CONNECTOR)	
	CN60	K1KA03B00201	CONNECTOR, 3PIN	
			(RESISTOR)	
	R62	ERJ3GSYJ181	180	S
			(PHOTO ELECTRIC TRANSDUCER)	
	PI62	B3NAA0000105	PHOTO ELECTRIC TRANSDUCER	

18.2.7.21. MPT Relay Board(For MB2515/2545/2575/310EU)

Safety	Ref. No.	Part No.	Part Name & Description	Remarks
	PCB17	PNLPB257JT-T	MPT RELAY BOARD ASS'Y (RTL)	
			(DIODE)	
	D55	DA2J10100L	DIODE (SI)	
			(CAPACITOR)	
	C52	ECUV1H102KBV	0.001	S
			(CONNECTORS)	
	CN55	K1KA04A00527	CONNECTOR, 4PIN	
	CN75	K1KA02A00587	CONNECTOR, 2PIN	
			(RESISTOR)	
	R56	ERJ3GSYJ181	180	S
			(PHOTO ELECTRIC TRANSDUCER)	
	PI61	B3NAA0000106	PHOTO ELECTRIC TRANSDUCER	

18.2.7.22. Antenna(V) Board(For MB2270/2575EU)

Safety	Ref. No.	Part No.	Part Name & Description	Remarks
	PCB18	PNLPB257JT-V	VERTICAL ANTENNA BOARD ASS'Y (RTL)	

18.2.7.23. Antenna(H) Board(For MB2270/2575EU)

Safety	Ref. No.	Part No.	Part Name & Description	Remarks
△	SCR21	PD5112AL002	THYRISTOR	

Safety	Ref. No.	Part No.	Part Name & Description	Remarks
	PCB19	PNLPB257JT-W	HORIZONTAL ANTENNA BOARD ASS'Y (RTL)	

18.2.7.24. Back Light Board(For MB2515/2545/2575/310EU)

Safety	Ref. No.	Part No.	Part Name & Description	Remarks
	PCB20	PNLPB257JTB	LCD BACK LIGHT BOARD ASS'Y (RTL)	

18.2.7.25. One Touch Key Board(For MB310EU)

Safety	Ref. No.	Part No.	Part Name & Description	Remarks
	PCB21	PNLPB310JT-U	ONE TOUCH KEY BOARD ASS'Y (RTL)	
			(SWITCHES)	
	SW52	KOH1BA000259	SPECIAL SWITCH	
	SW53	KOH1BA000259	SPECIAL SWITCH	
	SW54	KOH1BA000259	SPECIAL SWITCH	
	SW55	KOH1BA000259	SPECIAL SWITCH	

18.2.8. High Voltage Power Supply Board

Safety	Ref. No.	Part No.	Part Name & Description	Remarks
△	PCB22	N0GG4E000006	High Voltage Power Board (RTL)	
			(IC)	
	IC1	PH1193AC001	IC	
			(TRANSISTORS)	
	Q3	PT2394DL001	TRANSISTOR (SI)	
	Q62	PT2394DL001	TRANSISTOR (SI)	
			(OTHERS)	
△	F1	PK7130AA001	FUSE	
△	SW1	PFSHSS3FLP3D	PUSH SWITCH	S

18.2.9. Low Voltage Power Supply Board

Safety	Ref. No.	Part No.	Part Name & Description	Remarks
△	PCB23	N0AC2GJ000010	Low Voltage Power Board (RTL)	
			(ICs)	
	IC1	PH3417AC001	IC	
	IC501	PH2274AC001	IC	
			(TRANSISTOR)	
△	Q1	PT1109ML001	TRANSISTOR (SI)	
			(DIODES)	
△	D10	PD1014AQ604	DIODE (SI)	S
△	Z1	PD7024AR002	DIODE (SI)	
			(CAPACITOR)	
△	C5	PC3248YS101	150p	
			(FUSES)	
△	F1	PK7135AS007	FUSE	
△	F2	PK7135AS004	FUSE	
△	F3	PK7174AZ002	FUSE	
△	F101	PK7175AR002	FUSE	
△	F102	PK7175AR002	FUSE	
			(OTHERS)	
△	RL1	PK3103AL005	RELAY	

PBS
KXMB2230EU
KXMB2270EU
KXMB2515EU
KXMB2545EU
KXMB2575EU
DPMB310EU